

USER MANUAL

Swish Trampoline Basketball Ring with Metal Swing Set Adaptor



WARNING: The disassembled product may contain small parts which pose a choking hazard to children under 3.

IMPORTANT:

This product may contain sharp points and small parts prior to assembly. The owner's manual contains safety, assembly, use and maintenance instructions. This product must be assembled by an adult who has read and understood these instructions. Keep the packaging away from children and dispose of all packaging before use.

For the installer and your children's safety, it is important to fully read and understand the instructions and safety hazards before commencing the assembly of the product.

NOTE:

This manual should not be used to guide your purchasing decision. Your product, and the contents inside its carton, may vary from what is listed in this manual. This manual may also be subject to updates or changes. Updated manuals are available through our website at www.lifespankids.com.au.

TABLE OF CONTENTS

I. GENERAL SAFETY INSTRUCTIONS	4
II. SAFETY INSTRUCTIONS	6
III. SWISH TRAMPOLINE BASKETBALL RING ASSEMBLY INSTRUCTIONS	8
IV. BASKETBALL BRACKET ASSEMBLY INSTRUCTIONS	13
V. MAINTENANCE	16
VI. CLEANING	17
VII. WARRANTY	17

I. GENERAL SAFETY INSTRUCTIONS

 **NOTE:** Compatibility cannot be guaranteed with other brand trampolines

It is the responsibility of the owner to become familiar with the safety rules and to convey these rules to all users.

- Read and follow all of the warnings and use instructions for your trampoline and safety enclosure.
- Read and follow all rules specified on the warning labels that came with your trampoline safety enclosure and basketball set. If labels or signs become lost or unreadable please replace.
- The Swish Basketball Ring should be used only as described in this manual. The basketball set must only be mounted to a compatible safety enclosure system. It should never be mounted on any other device in any manner not described in this manual. Do not attach anything to the basketball set or safety enclosure that is not a manufacturer approved accessory or part of the enclosure system.
- Do not allow more than one person on the trampoline. Do not allow more than one person inside the trampoline enclosure. Use by more than one person at the same time can result in serious injury. This includes "one-on-one" type games and any other games or activities where more than one person is on the trampoline at the same time.
- Do not hang from, kick or climb on any part of the basketball set or safety enclosure.
- Remove all jewellery watches and hair clips before using the basketball set.
- Wear clothing free of drawstrings hooks loops or anything that could get caught in the basketball set or safety enclosure.
- Do not use the trampoline or basketball set while under the influence of alcohol or drugs.
- Do not install the basketball set on a pole that is near or over a missing or damaged frame pad.
- When not in use store the basketball provided with your set in a dry location.
- Use the trampoline and basketball set only with mature, knowledgeable supervision.
- Do not hang on the hoop. While the Swish Basketball Set is designed to withstand rigorous use the hoop is not designed to be hung on. Hanging on the hoop can damage the enclosure pole and trampoline to which the basketball set is installed. Damage resulting from hanging on the hoop is not covered by warranty.

Overhead Clearance

Adequate overhead clearance is essential. A minimum of 24 feet from ground level is recommended. Provide clearance for wires, tree limbs and other possible hazards.

Lateral Clearance

Lateral clearance is essential. Place the basketball set away from walls, structures, fences, and other play areas. Maintain a clear space on all sides of the trampoline and trampoline enclosure.

Level Surface

Place the trampoline and trampoline enclosure on a level surface before installing and using the basketball set.

Lighting

Use the basketball set in a well-lighted area. Artificial illumination may be required for indoor or shady areas.

Security

Secure the trampoline and trampoline enclosure against unauthorized and unsupervised use.

Underneath Clearance

Remove any obstructions from beneath the trampoline and trampoline enclosure.

**NOTE:**

The trampoline enclosure is only to be used as an enclosure for a trampoline and the trampoline must be of the appropriate size as covered by the specific enclosure.

The trampoline enclosure is only to be used as an enclosure for a trampoline and the trampoline must be of the appropriate size as covered by the specific enclosure

II. SAFETY INSTRUCTIONS

- The safety instructions of the product should always be considered and obeyed.
- Using the product may result in permanent injury such as paralysis, or even death. Falling off the product may lead to injuries, particularly to the back, neck or head.
- No clothes with hooks or loose parts should be worn or carried during product usage in order to avoid hooks getting caught and causing injury.
- Strong winds can result in the product being blown away or damaged. If strong winds are predicted the product must be disassembled and moved to a sheltered area or sufficiently anchored down.
- Moving the product whilst assembled may affect the integrity of the frame. Should it be necessary to move the product, please consider the following:
 1. Force to be evenly spaced around the frame to lift the product off the ground.
 2. The product must be carried horizontally.
 3. Use caution whilst moving as it could bend the product frame.
- Users should be familiar with the assembly manual. This manual contains assembly guidance; selected precautionary measures as well as recommendations for servicing and maintenance of the product, in order to ensure a secured and fun use of the product.
- It is the responsibility of the owner or the supervisor to guarantee that all users of the product are informed sufficiently of all warning references and safety instructions.

For the supervisor

The supervisor's role is to make sure users are aware of all safety precautions and that these precautions are enforced. When a supervisor is not available, the product may be disassembled or covered to limit access.

- The product can be only used if it is in good condition, worn or damaged parts should be replaced.
- Objects, which could be dangerous to the user, should be away from the product.
- Avoid unauthorized and unsupervised use of the product.
- Do not use the product under influence of alcohol or drugs (incl. medicines).
- Do not use the product as a jumping platform for other articles.

Consumer Information Sheet for Playground Surfacing Materials

The US Consumer Product Safety Commission (CPSC) estimates that about 100 000 playground equipment-related injuries resulting from falls to the ground surface are treated annually in US hospital emergency rooms. Injuries involving this hazard pattern tend to be among the most serious of all playground injuries, and have the potential to be fatal, particularly when the injury is to the head. The surface under and around playground equipment can be a major factor in determining the injury-causing potential of a fall. It is self-evident that a fall onto a shock-absorbing surface is less likely to cause a serious injury than a fall onto a hard surface. Playground equipment should never be placed on hard surfaces, such as concrete or asphalt, and while grass may appear to be acceptable, it may quickly turn to hard-packed earth in areas of high traffic. Shredded bark mulch, wood chips, tine sand or the gravel are considered to be acceptable shock absorbing surfaces when installed and maintained at a sufficient depth under and around playground equipment.

Table B.1 lists the maximum height from which a child would not be expected to sustain a life-threatening head injury in a fall on to four different loose-fill surfacing materials if they are installed and maintained at depths of 150 mm, 225 mm and 300 mm.

TABLE B.1: Fall height in millimetres from which a life-threatening head injury would not be expected.

TYPE OF MATERIAL	DEPTH OF SURFACING MATERIAL		
	150mm	225mm	300mm
Double Shredded Bark Mulch	1800	3000	3300
Wood Chips	1800	2100	3600
Fine Sand	1500	1500	2700
Fine Gravel	1800	2100	3000

However, it should be recognised that all injuries due to falls cannot be prevented, no matter what surfacing material is used.

It is recommended that a shock absorbing material extend a minimum of 1800mm in all directions from the perimeter of stationary equipment such as climbing frames and slides. However, because children may deliberately jump from a moving swing, the shock absorbing material should extend in the front and rear of a swing a minimum distance of twice the height of the pivot point measured from a point directly beneath the pivot on the supporting structure.

This information is intended to assist in comparing the relative shock-absorbing properties of various materials. No particular material is recommended over another. However, each material is only effective when properly maintained. Materials should be checked periodically and replenished to maintain correct depth as determined necessary for the equipment in question. The choice of a material depends on the type and height of the playground equipment, the availability of the material in a particular area, and its cost.

III. SWISH TRAMPOLINE BASKETBALL RING ASSEMBLY INSTRUCTIONS

PARTS LIST

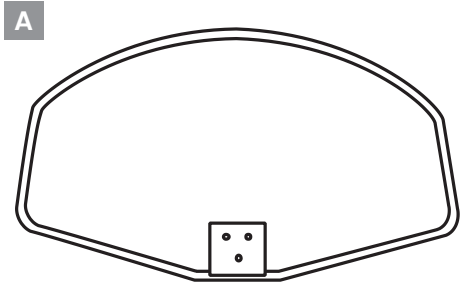

Backboard x 1

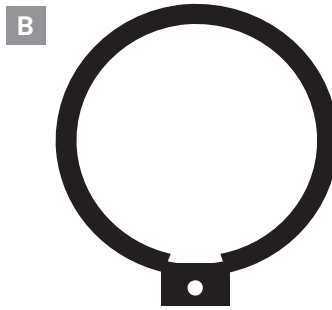

Ring x 1

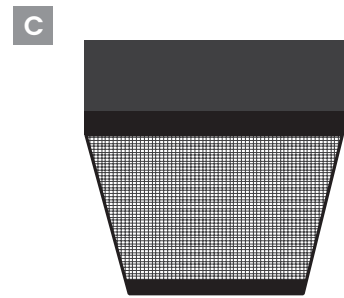

Net x 1

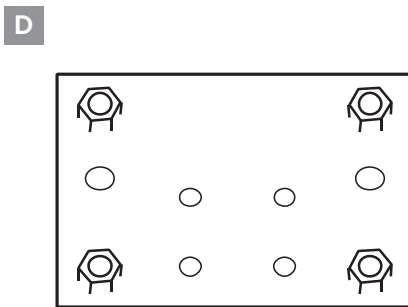

Flat Plate x 2

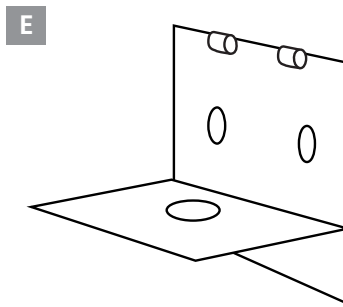

Connection Plate x 1

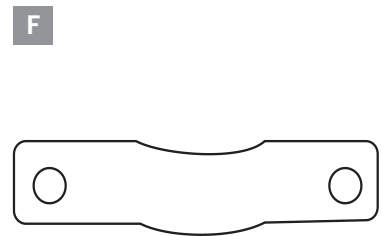

Clamp x 2

G

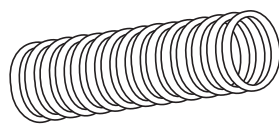

Short x 1

H

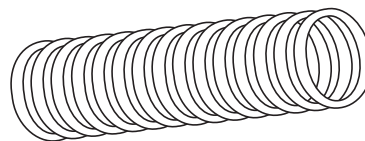

Long x 1

FITTINGS

L-1



M6 x 3

L-2

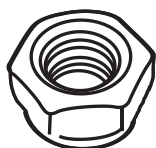

M8 x 5

L-3



M5 x 1

M-1



M6 x 6

M-2

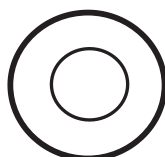

M8 x 7

1

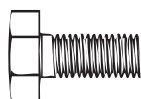

M8 x 12mm (2pcs)

2

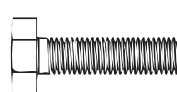

M6 x 35mm (3pcs)

3

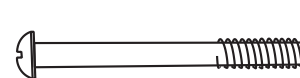

M5 x 75mm (1pc)

4

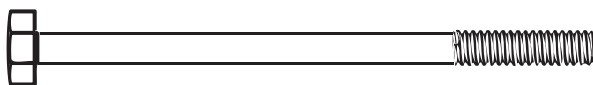

M8 x 100mm (1pc)

5



M8 x 40mm (4pcs)

Preparation:

Remove all parts and hardware from the carton and place them on a clean soft surface. Check carefully to make sure nothing is missing. Dispose of all packaging material properly. Please recycle.

The following items are required for assembly (not included):

- Two adjustable wrenches; or wrenches or sockets in the following sizes: 10mm, 13mm and 17mm.

TOOL

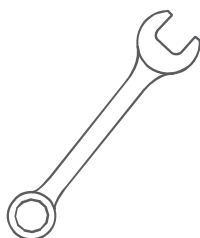

10mm

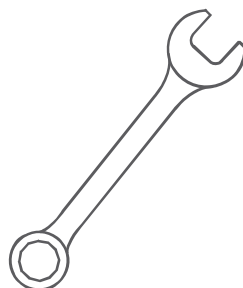

13mm

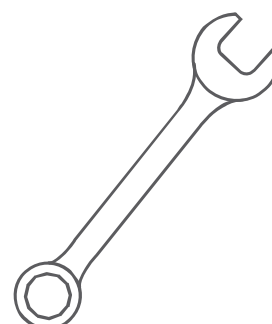

14mm

STRAIGHT POLE INSTALLATION

STEP 1:

Attach the net on the loop as the picture showing.

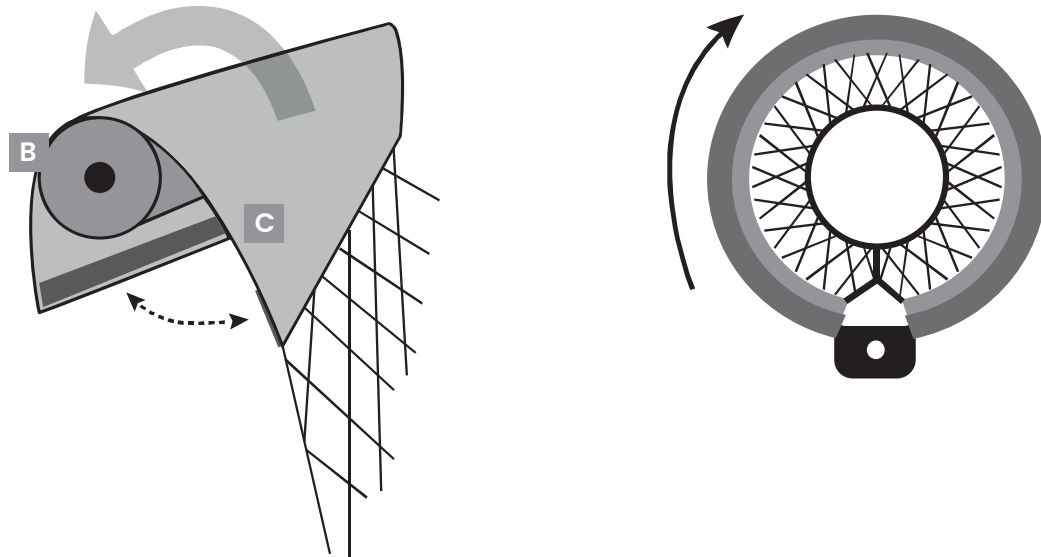

! **NOTE:** Some components may have been pre-assembled

STEP 2:

Connect the ring B with connection plate E by using the bolt 3 through the joint and locked with L-3.

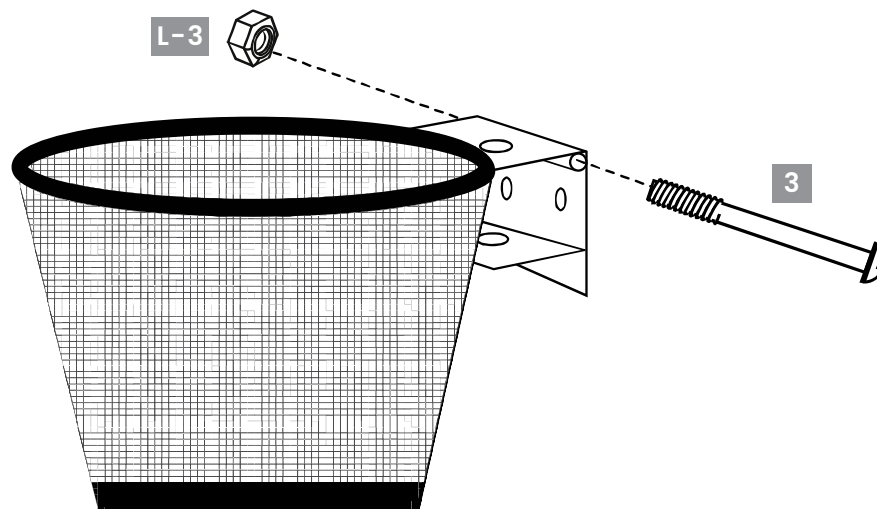

! **NOTE:** Ensure the bracket is fitted the right way up (larger section down) to allow the hoop to swing upwards against backboard.

STEP 3:

Attach the flat plate D on the backside of backboard A, locked by using two bolts 1 and two washers M-2, then to attach the ring B on the front of backboard at the joint by using three nuts L-1 through six washers M-1 and three 2. Then to fit the spring on the connection plate as the figure shows.

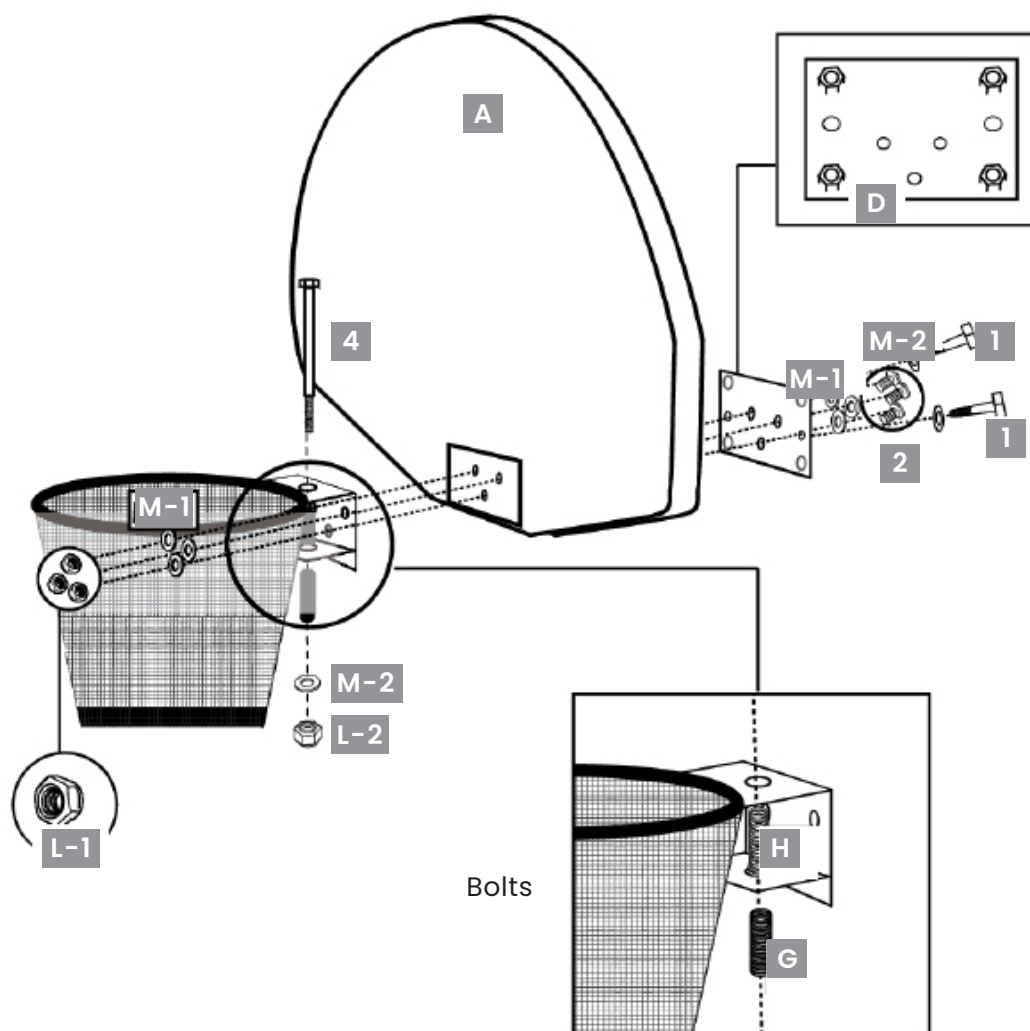

! **NOTE:** Ensure the bracket is fitted the right way up (larger section down) to allow the hoop to swing upwards against backboard.

STEP 4:

Attach the whole basketball set onto the ideal safety poles of your trampoline, lock it with two clamps F by using four bolts 5 through four washers M-2 and four nuts L-2.

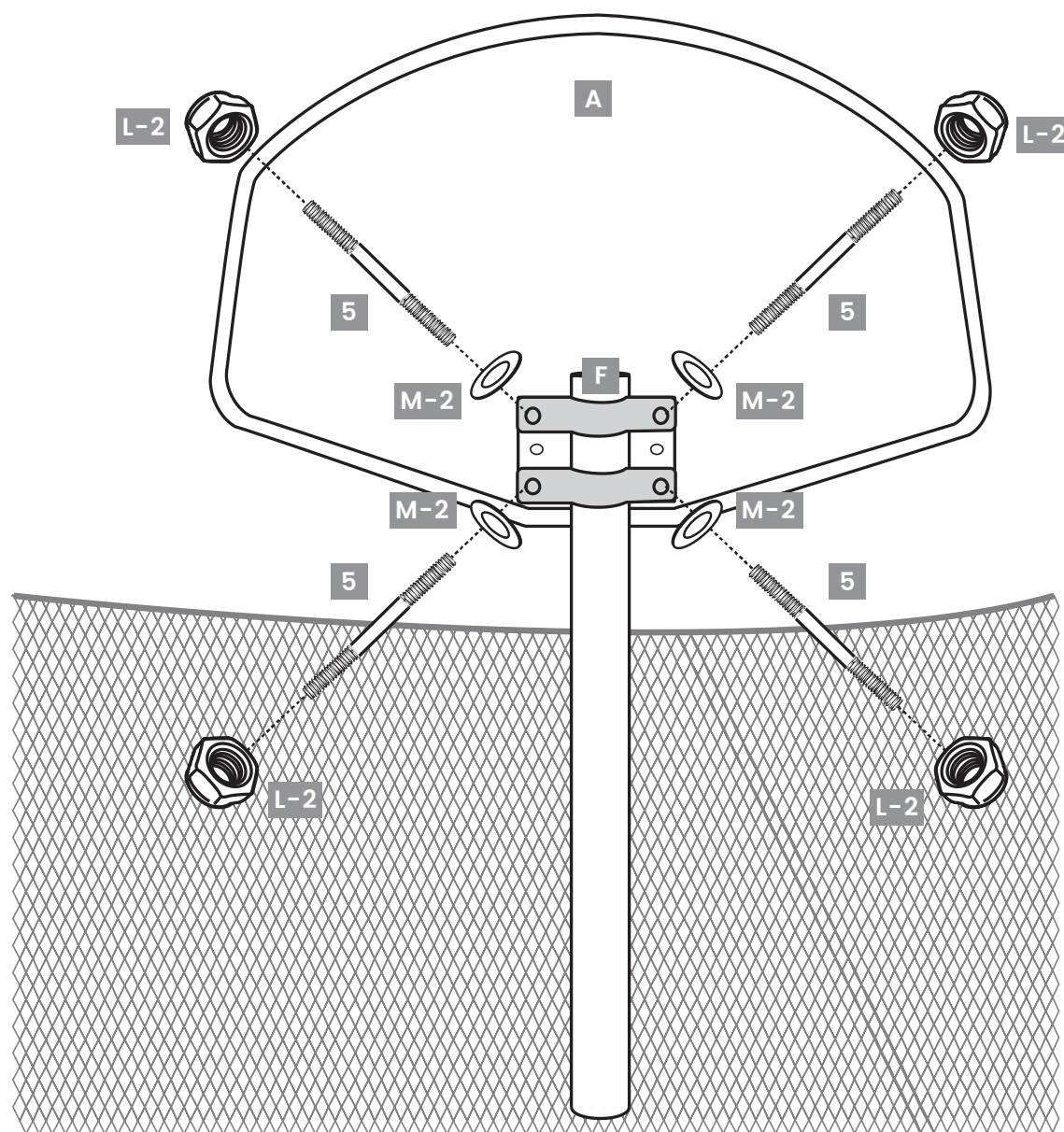

! **NOTE:** Ensure the bracket is fitted the right way up (larger section down) to allow the hoop to swing upwards against backboard.

IV. BASKETBALL BRACKET ASSEMBLY INSTRUCTIONS



WARNING: The disassembled item contains small parts which pose a choking hazard to children under 3.

PURPOSE

This part is intended for the attachment of the Swish basketball ring to the Hurley metal swing set.

PARTS LIST



1 x Bracket

TOOL REQUIREMENTS:

1. 10mm Spanner
2. 6mm Allen key flat head screwdriver
3. Gloves (recommended for safety)

BASKETBALL BRACKET INSTALLATION

STEP 1:

Remove the end cap and unfasten one bolt. (Refer to Figure 2)

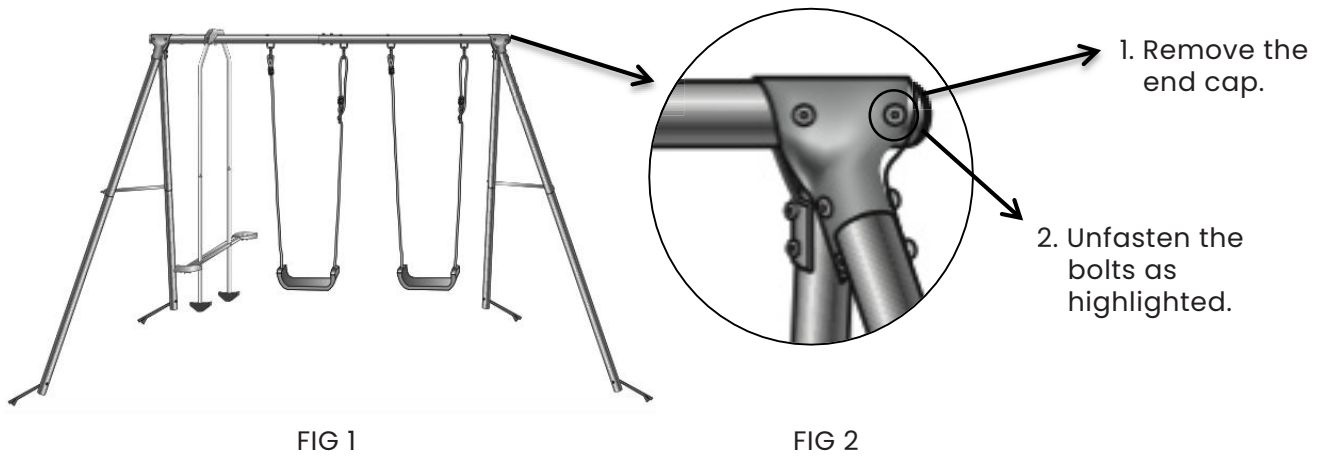

STEP 2:

Insert the bracket into the end of swing frame (fig 3). Then use the previous bolt to fit and tighten the nut properly.

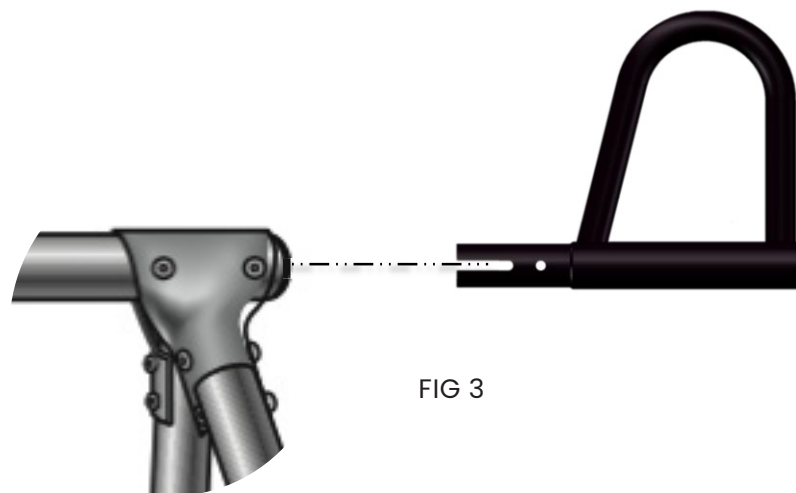

STEP 3:

Refer to the instructions supplied with basketball ring to complete assembly.



FIG 4



FIG 5



FIG 6

V. MAINTENANCE



WARNING: Please keep for future reference.

We recommend regular maintenance to be conducted at the beginning of each season as well as at regular intervals during the usage session for your play equipment to ensure all main parts/fixings are tightly secured, well-oiled and intact to avoid failure, injury or hazards.

GENERAL ADVICE

It is of particular importance that this is followed at the beginning of each season as well as at regular intervals during the usage season.

- Check the accessories monthly as well as the play equipment's structure to prevent falling risks.
- Check and retighten screws, bolts, and all other hardware elements as necessary.
 - a. Do not over tighten to avoid damaging the thread or cracking the surrounding wood.
- Check all coverings and bolts for sharp edges and replace when required.
- Lubricate all moving metallic parts.
- When signs of oxidation and / or rust appear on various metallic parts of your equipment, sand rusted areas and tubular members and repaint using a non-lead-based paint when required.
- Where applicable: check swing seats, chains, ropes, and other means of attachment for evidence of deterioration.
- Replace when required in accordance with the owner's manual.

If your play structure is disassembled, be sure to clearly mark any attached metal plates to prevent accidents. Check all bolt covers and sharp edges and replace them if necessary.

For longer accessory life, we suggest storing them during the winter.

VI. CLEANING

Do not use any abrasive cleansers for the cleaning. Use a soft, damp cloth to eliminate dirt and dust.

VII. WARRANTY

AUSTRALIAN CONSUMER LAW

Many of our products come with a guarantee or warranty from the manufacturer. In addition, they come with guarantees that cannot be excluded under the Australian Consumer Law. You are entitled to a replacement or refund for a major failure and compensation for any other reasonably foreseeable loss or damage.

You are entitled to have the goods repaired or replaced if the goods fail to be of acceptable quality and the failure does not amount to a major failure. Full details of your consumer rights may be found at www.consumerlaw.gov.au.

Please visit our website to view our full warranty terms and conditions:

www.lifespankids.com.au/Warranty-Policy-Kids

WARRANTY AND SUPPORT

Any claim against this warranty must be made through your original place of purchase. Proof of purchase is required before a warranty claim may be processed. If you have purchased this product from the Official Lifespan Kids website, please visit www.lifespankids.com.au/warranty-form

For support outside of warranty, if you wish to purchase replacement parts or request a repair or service, please visit www.lifespankids.com.au/warranty-form and fill in our Repair/Service Request Form or Parts Purchase Form.

