

USER MANUAL

Windsor 2 Slide & Splash Inflatable



WARNING: Children have drowned in portable swimming pools. Ensure active adult supervision at all times. Do not leave children unsupervised in or around the pool — keep them within arm's reach. Empty and store safely after use. DO NOT USE this product during bad weather conditions.

IMPORTANT:

The owner's manual contains safety, assembly, use and maintenance instructions. This product must be assembled by an adult who has read and understood these instructions. Keep the packaging away from children and dispose of all packaging before use. Do not allow children to operate machine. Children to stay clear of air fan blower at all times. Please save these instruction for future use.

Recommended for ages between 3–10. For family domestic outdoor use only.

Only a competent adult must set up this product following the instruction provided. Do not allow children to operate the air fan blower at any time

NOTE:

This manual should not be used to guide your purchasing decision. Your product, and the contents inside its carton, may vary from what is listed in this manual. This manual may also be subject to updates or changes. Updated manuals are available through our website at www.lifespankids.com.au.

For the installer and your children's safety, it is important to fully read and understand the instructions and safety hazards before commencing the assembly of the product.

TABLE OF CONTENTS

I. BEFORE USING THE PRODUCT	3
II. SAFETY INSTRUCTIONS	4
III. USING THE PRODUCT	6
IV. STORAGE	7
V. SET UP	8
VI. CLEANING	9
VII. WARRANTY	9

I. BEFORE USING THE PRODUCT

NOTE: This product is intended for outdoor domestic use only.

1. Place the product on a level surface at least 2 metres away from any hazard, structure or obstruction such as fence, garage, house, overhanging branches, laundry lines or electrical wires.

DO NOT place on hard surface such as concrete or asphalt as a fall onto a hard surface can cause serious injury.

2. Clear the play area of all sharp objects such as stones, twigs or any other object that can cause injury to the players and/or damage to the structure's construction.
3. Unpack the inflatable structure and unfold fully as shown in (Fig.1).
4. Unpack the air fan blower from its carton and follow the operating instructions **BEFORE** attaching to the structures airflow inlet tube as shown in (Fig.2). The nylon inlet tube is simply attached around the fan's outlet by tying the cord tightly behind the tube's flange.
5. The jumping castle must be anchored to the ground using ground pegs at each fixing point on the structure (Fig.3) to prevent overturning or lifting during use. Ensure that the pegs are level with or under the ground to reduce tripping hazards.
6. Connect the air fan blower to a suitable electric earthed socket **ONLY**.
7. **DO NOT USE** this product during bad weather conditions. Strong winds can uplift this product causing serious injury or death.
8. Children should remove shoes and any sharp or pointed objects such as buckles on belts, eyeglasses etc. as these could cause injury to themselves and/or damage to the structure.
9. Plug in the air fan blower and switch on. The jumping castle should inflate within 90 seconds. If it is taking longer check that the air inlet tube is not obstructed.



IMPORTANT:

1. Air seepage through seams of the structure is normal, as some air needs to escape due to the design of the product.
2. Do not use unless all air compartments are inflated.

II. SAFETY INSTRUCTIONS

 **WARNING!**

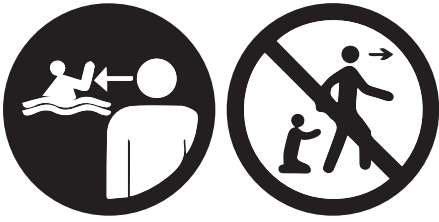

- Never leave your child unattended – drowning Hazard.
- Children have drowned in portable swimming pools. Always ensure active adult supervision and do not leave children unsupervised in or around the pool.
- Keep them within arm's reach.
- Empty and store safely after use.

1. Failure to follow the specified instructions could result in serious injury.
2. Keep the product a safe distance (at least 2 m) from fire, walls, and other obstructions.
3. The product may not be used outside in rainy and / or lightning conditions or if winds exceed 40km/h (25 MPH). Sudden gusts of wind may lift the product off the ground
4. The product must be fully inflated before any children are allowed inside. The product must stay fully inflated until everyone is out.
5. If the product begins to deflate, remove all children, and check for disconnection of power cord or for power outage.
6. Do not drag on concrete or other rough surfaces.
7. Unauthorized modification of the product is not allowed.
8. Product should be checked regularly for potentially unsafe conditions such as damaged cord, plug, housing, or parts. If such damage is found, the product should not be used until properly repaired.
9. To reduce the risk of fire or electric shock, do not use the blower with any solid-state speed control device.
10. Check stakes regularly during playing to ensure they remain secure in the ground.
11. Adult set-up and dismantling are required. Adult supervision is always required while the product is in use.
12. Ages and sizes of children playing in the product at the same time should be comparable. Not suitable for children under 3 years. Small parts may be swallowed. Never leave children unattended during playing.
13. Keep children and pets away from the blower (air pump).
14. Individuals with head, neck, back or other muscular-skeletal injuries or disabilities, small infants, pregnant women, and others who may be susceptible to injury from falls, bumps or bouncing are not permitted in the product.
15. Instruct children on proper use of this product. Do not use in a manner other than intended.

16. Never slide down headfirst to avoid the risk of serious injury or death. Keep arms away from the two sides of the slide when sliding down to avoid a risk of skin injuries.



Do not touch the two sides of the slide.

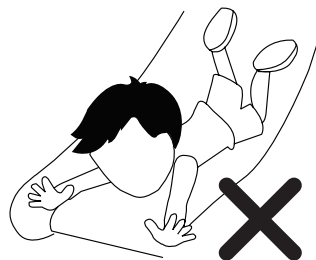

Never slide down head first

17. Children are required to slide down with proper posture (refer to the following pictures) when playing on the product with slide.



Sit on the platform, do not stand up.



Cross your hands over chest before sliding down.

OR

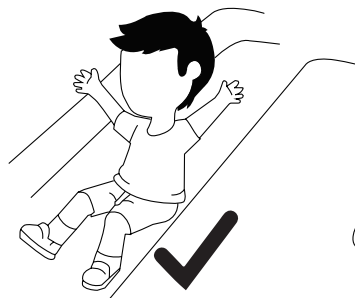

Slide with arms UP on this slide.



Sliding finish.

18. Shoes, eyeglasses, jewellery and any hard or sharp objects that may cause injury must be removed before entering the product. Loose or baggy clothing or clothing containing long cords should not be worn while playing on this product.
19. To prevent choking, children may not enter the product while eating, drinking, or chewing anything in their mouth.
20. No flipping, wrestling, running, or pushing is allowed inside the product.
21. Do not bounce on the edges, steps. Climbing or hanging on the walls, netting or exterior of the product is not allowed.
22. Make sure the water slide is 100% dry before folding and storing in the carry bag, make sure the water jet and water bags put separately with the water slide. Please store your product in dry condition. Keep away from sun and rain. If the water slide has mould and the fabric weakens due to the inappropriate storage conditions, it will be outside of warranty.
23. The carry bag is not a TOY, but for storage use only.
24. In case of injury, contact a physician immediately.
25. Children can drown in small amounts of water. Empty the pool when not in use.
26. Changes to the original toy shall be carried out according to the instructions of the retailer of the original toy.
27. Change the water of paddling pool frequently (particularly in hot weather) or when noticeably contaminated.

III. USING THE PRODUCT

Jumping castles can be dangerous and must always have competent adult supervision. Do not leave children unattended.

Follow weight limits below.

Maximum individual user weight 30kg (66lbs).

MODEL NAME	MAXIMUM USERS
Windsor 2 Slide and Splash	3

1. Always remove shoes and sharp objects before using the inflatable.
2. Do not allow children to wrestle, flip or pile on the top of others as this may result in serious injury.
3. Always ensure children keep hands and feet inside the jumping castle during use.
4. The entire product must be inspected before each use to ensure no damage has been caused which could cause risk of injury.



IMPORTANT:

The Air Fan Blower must remain connected to the power supply and running throughout the playing period otherwise the structure will deflate. The fan is designed to run for sustained periods.

IV. STORAGE

1. All children must be off the inflatable before turning off the fan blower.
2. Deflate the structure by switching off the fan. Untie the air inlet nylon tube from air the air pump fan's outlet pipe by un-tying the cord (Fig.5). Remove ground pegs from the structure and the fan and place in store bag.
3. Once all the air has escaped it can be folded and place into the store bag (Fig.6).
4. The air pump fan should be unplugged from the mains supply power socket and stored in carton.

DON'T

- Do not use on water.
- Do not inflate/deflate while children are on the inflatable to avoid suffocation.
- Do not move or reposition the inflatable while children are on it.
- Do not drag across rough surfaces.
- Do not drink or eat to prevent choking while inside.
- Do not leave the inflatable outdoors when not in use.
- Do not allow pets to enter the inflatable.

DO

- Do wear socks during hot season.
- Do allow similar size children only to avoid accidents.
- Do read the instructions before use and keep it for reference.
- Do store out of the sun in cool dry conditions when not in use.
- Do inspect the product for any damage before each use.

V. SET UP

FIG 1

Unpack from the bag. Unfold and lay out inflatable flat on the ground, face up.

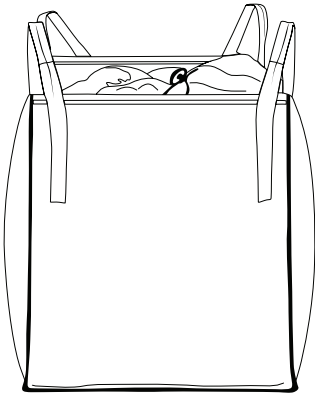

FIG 2

Tie air intake sleeve to blower, and connect to air socket.

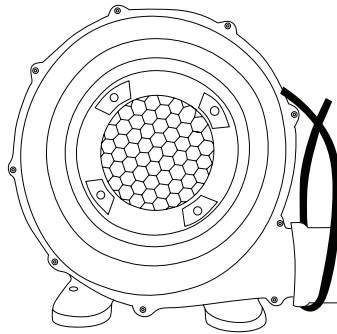

FIG 3

If possible, place pegs through straps and push to secure in the ground.

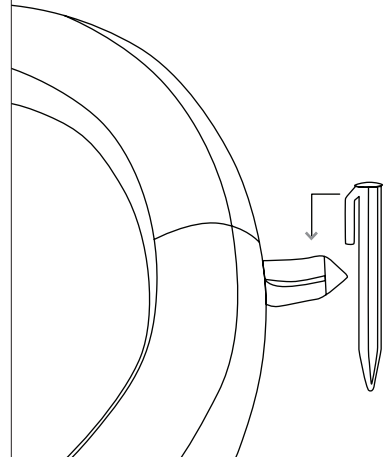
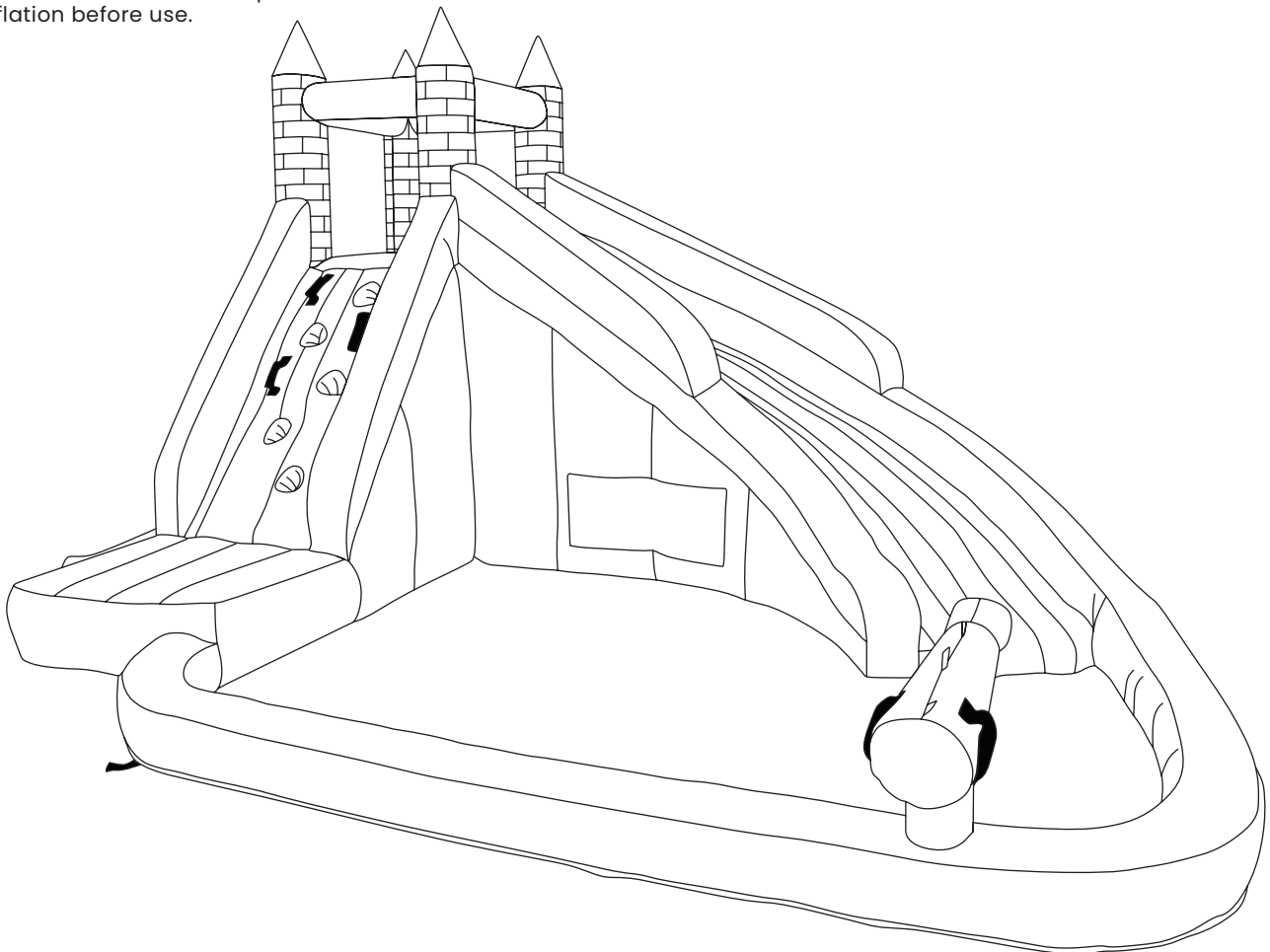

FIG 4

Wait for Inflatable to complete inflation before use.



VI. CLEANING

Do not use any abrasive cleansers for the cleaning. Use a soft, damp cloth to eliminate dirt and dust.

VII. WARRANTY

AUSTRALIAN CONSUMER LAW

Many of our products come with a guarantee or warranty from the manufacturer. In addition, they come with guarantees that cannot be excluded under the Australian Consumer Law. You are entitled to a replacement or refund for a major failure and compensation for any other reasonably foreseeable loss or damage.

You are entitled to have the goods repaired or replaced if the goods fail to be of acceptable quality and the failure does not amount to a major failure. Full details of your consumer rights may be found at www.consumerlaw.gov.au.

Please visit our website to view our full warranty terms and conditions:
www.lifespankids.com.au/Warranty-Policy-Kids

WARRANTY AND SUPPORT

Please email us at support@lifespankids.com.au for all warranty or support issues.

For all warranty or support related enquiries, please lodge a support ticket first by sending us an email.
support@lifespankids.com.au.

