

# CORTEX®

## Revolock V2 24kg Adjustable Steel Dumbbell Barbell Kettlebell All-in-One

USER MANUAL



Product may vary slightly from the item pictured due to model upgrades.



**Read all instructions carefully before using this product.  
Retain this owner's manual for future reference.**

**NOTE:**

This manual should not be used to guide your purchasing decision. Your product, and the contents inside its carton, may vary from what is listed in this manual. This manual may also be subject to updates or changes. Updated manuals are available through our website at [www.lifespanfitness.com.au](http://www.lifespanfitness.com.au)



# TABLE OF CONTENTS

I. Important Safety Instructions .....	03
II. Equipment Maintenance Instructions .....	04
III. Product Introduction .....	04
IV. Parts List .....	06
V. Assembly Instructions .....	07
VI. Exercise Guide .....	11
VII. Warranty .....	13

# I. IMPORTANT SAFETY INSTRUCTIONS

Please keep this manual with you at all times.

- It is important to read this entire manual before assembling and using the equipment. Safe and effective use can only be achieved if the equipment is assembled, maintained, and used properly. **PLEASE NOTE:** It is your responsibility to ensure that all users of the equipment are informed of all warnings and precautions.
- Before starting any exercise program you should consult your doctor to determine if you have any medical or physical conditions that could put your health and safety at risk, or prevent you from using the equipment properly. Your doctor's advice is essential if you are taking medication that affects your heart rate, blood pressure or cholesterol level.
- Be aware of your body's signals. Incorrect or excessive exercise can damage your health. Stop exercising if you experience any of the following symptoms: pain, tightness in your chest, irregular heartbeat, and extreme shortness of breath, lightheadedness, dizziness or feelings of nausea. If you do experience any of these symptoms, you should consult your doctor before continuing with your exercise program.
- Never drop the dumbbells on the ground as this will damage the product.
- Do not attempt to disassemble the dumbbell.
- Keep children and pets away from the equipment. This equipment is designed for adult use only.
- Ensure you have adequate space when using the dumbbells for your exercise training.
- Before using the equipment, check that the locking mechanism is functioning properly. Do not use the equipment until the problem has been rectified.
- Wear suitable clothing while using the equipment. Avoid wearing loose clothing that may get caught in the equipment or that may restrict or prevent movement.
- This equipment is designed for indoor and family use only.
- Care must be taken when lifting or moving the equipment so as not to injure your back.
- Always keep this instruction manual and assembly tools at hand for reference.
- The equipment is not suitable for commercial use.
- Do not forcibly rotate the handle when it is stuck.
- For safety precautions, we recommend not to use this for overhead exercises.

# II. EQUIPMENT MAINTENANCE INSTRUCTIONS

Proper use of the product can prolong the service life. It is inevitable that parts will become loose after long-term use. Therefore, check the parts regularly to avoid damage to the parts and personal injury.

Please keep the equipment clean before and after use. Wipe it with warm soap water and dry it in a cool place. Keep out of reach of children.

For your safety, please read this manual carefully before using the product.

# III. PRODUCT INTRODUCTION

1. Barbell Model: There are 12 weight increments (both in kg and lb) as below chart:

<b>KG</b>	4	6	8	10	11.5	14	15	17	18.5	20	22	24
<b>LB</b>	8	14	19	21	25	29	34	38	40	43	48	54

2. Dumbbell Model: There are 12 weight increments (both in kg and lb) as below chart:

<b>KG</b>	3	6	8	9	11	13	15	17	18	19	21	24
<b>LB</b>	7	13	18	20	24	28	33	37	39	42	46	52.5

3. Kettlebell Model: There are 12 weight increments (both in kg and lb) as below chart:

<b>KG</b>	2	3	4	5	6	7	8	8.5	9	10	11	12
<b>LB</b>	4	7	9	11	13	15	17	19	20	21	23	27

Remark: Because the scale is marked by rounding, there may be errors in the actual weight and scale marking.

If you accidentally drop the dumbbell plate during use and cannot turn the gear with the handle, do not forcibly turn the handle. Follow these steps to reset the dumbbell.



1. Take out the handle and check whether there are convex point protruding from the card slot of the handlebar.

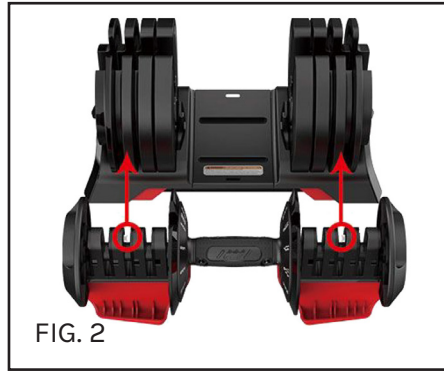

2. If there is a convex point protruding, please check the position of the dumbbell plate corresponding to the position of the convex point.

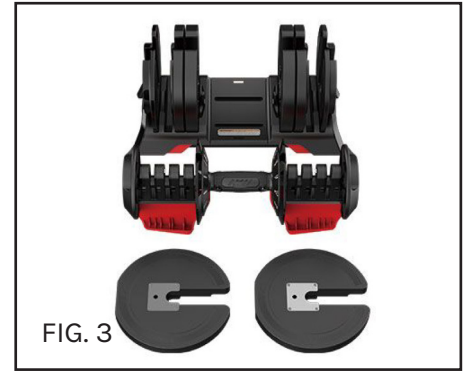

3. Take out the dumbbell piece in the dumbbell seat corresponding to the convex point.



4. Put the handle back into the dumbbell seat, and adjust the gear to the minimum value. At this point, the raised point retract to its original position.

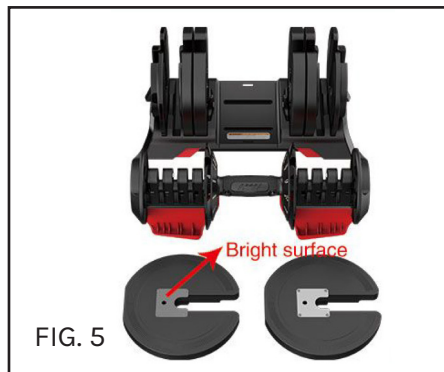

5. Please note that the bright surface faces inward when putting back the dumbbell piece.



6. Take the handle out and put the dumbbell back on. Now you can use your dumbbell normally.



Must adjust the number to the marker point before lifting the dumbbell (it can be sensed by the clicking sound and the vibration of the handle).

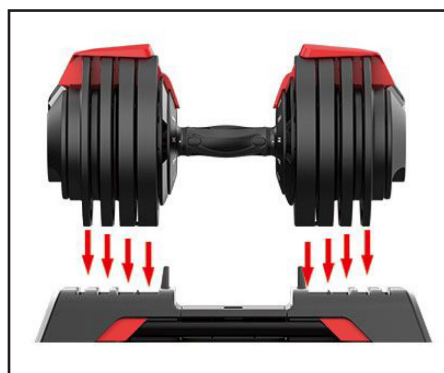

Make sure that each dumbbell plate is aligned with the corresponding groove on the base.

# IV. PARTS LIST

Item Name	Qty	Pic.
Kettlebell Handle	1	
Bolt	2	
Connecting Rod of the Handle of Barbell	2	
Handle of Barbell	1	
Screw	4	
Socket Head Wrench	1	
Plastic Connecting Sleeve of Barbell Base	4	
Connecting Rod of the Barbell Base	4 (2 long & 2 short)	

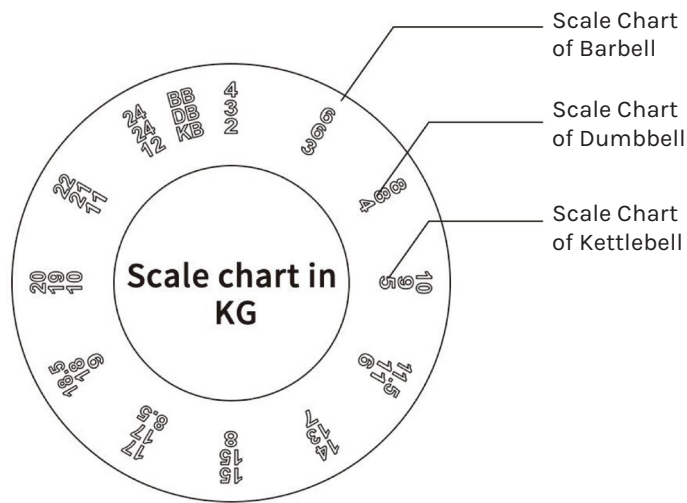

# V. ASSEMBLY INSTRUCTIONS

## DISASSEMBLE STEPS OF THE HANDLE

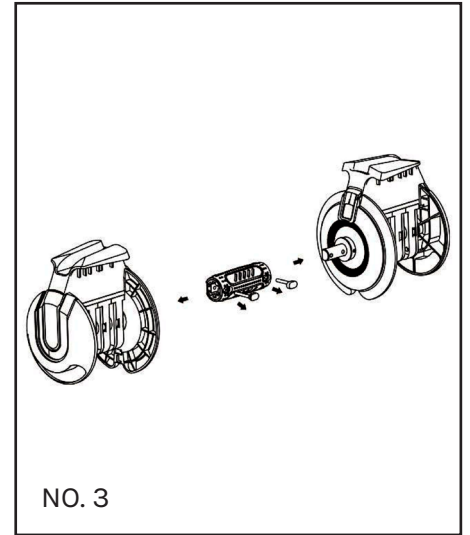
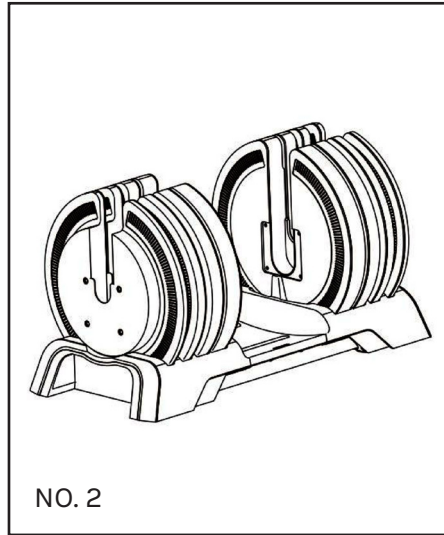
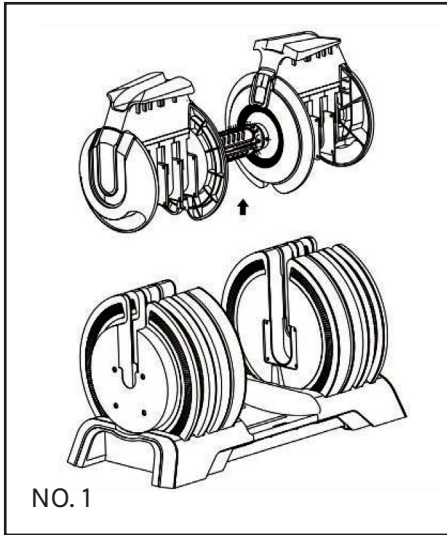

### Dumbbell Model:

Adjust the dumbbell to the minimum weight, then take out the handle.

Keep all barbell pieces on the base, make sure the stainless steel side of all dumbbell pieces are facing inward.

Take out the bolts and disassemble the handle as shown.

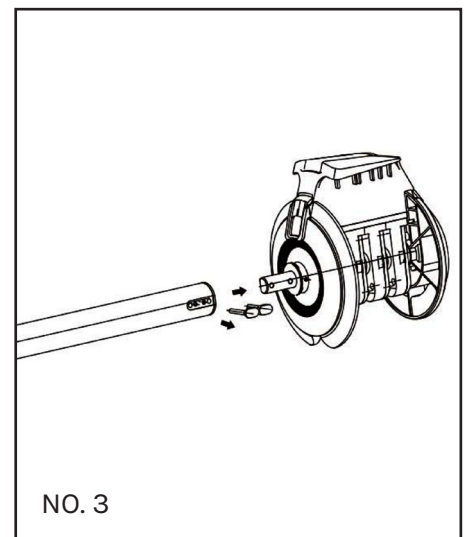
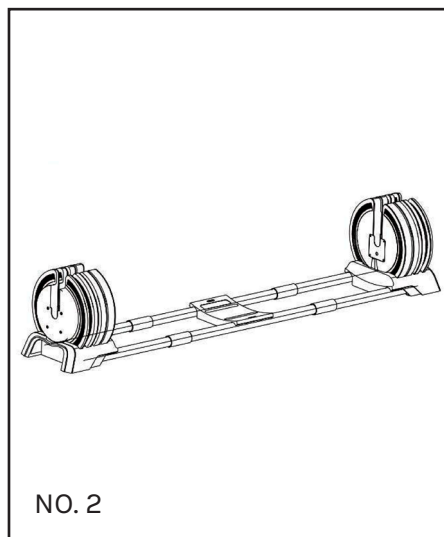
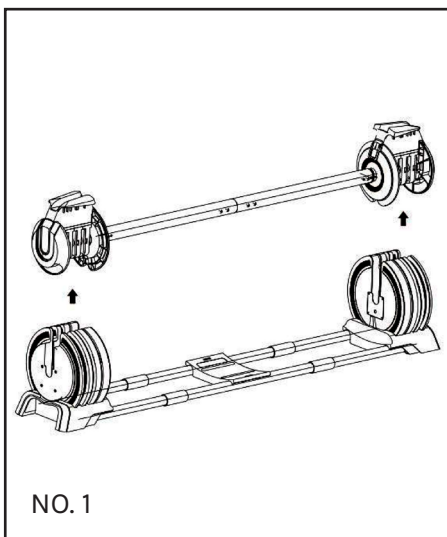

### Barbell Model:

Adjust the barbell to the minimum weight, then take out the handle.

Keep all barbell pieces on the base, make sure the stainless steel side of all dumbbell pieces are facing inward.

Take out the bolts and disassemble the handle as shown.

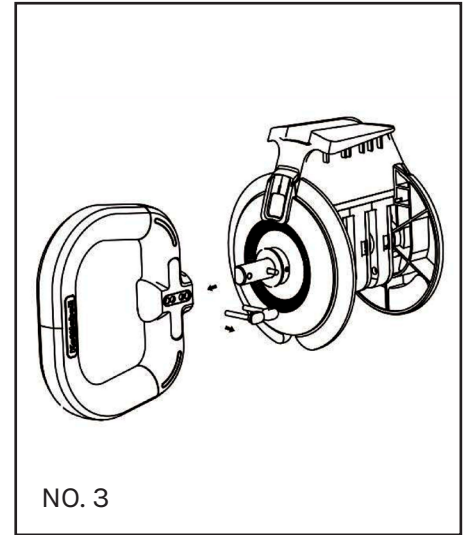
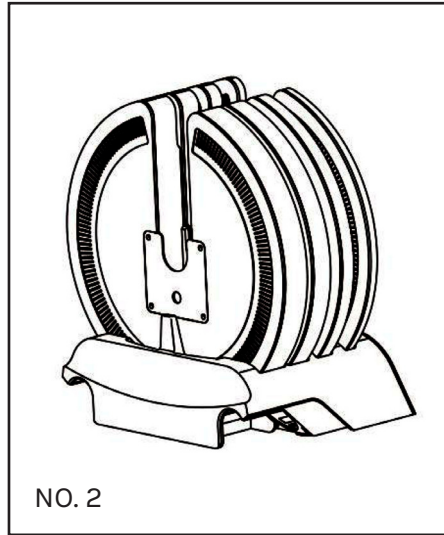
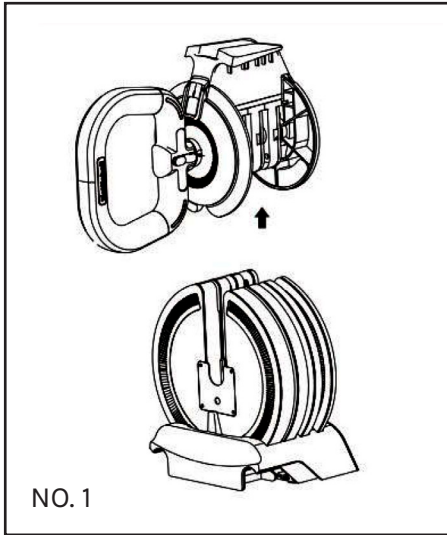

### Kettlebell Model:

Adjust the barbell to the minimum weight, then take out the handle.

Keep all barbell pieces on the base, make sure the stainless steel side of all dumbbell pieces are facing inward.

Take out the bolts and disassemble the handle as shown.

### ASSEMBLE STEPS OF BARBELL

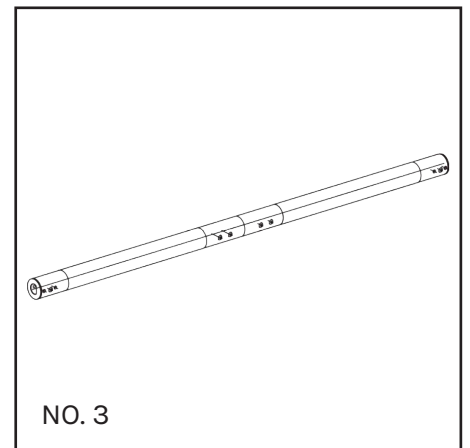
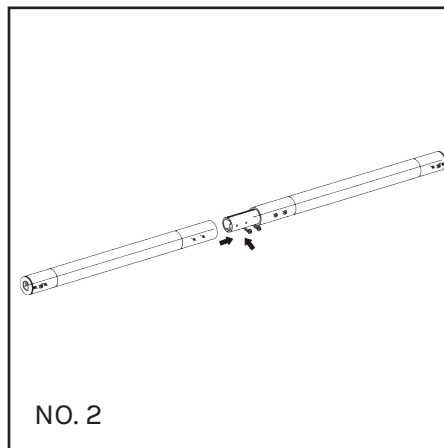
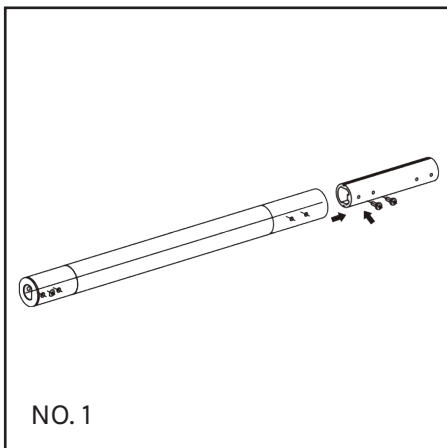

Install the handle of the Barbell on the connecting rod by screws as shown.

In the same way, install the other handle of the Barbell on the connecting rod by screws as shown.

As shown in the picture: The barbell handle is assembled.



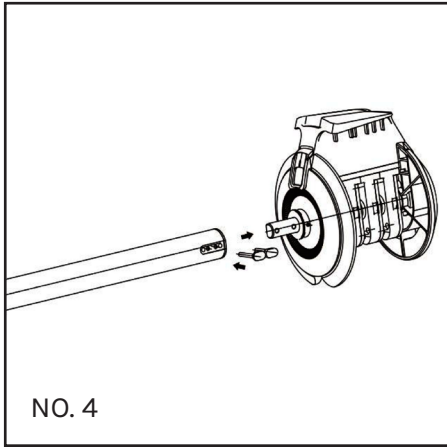

Install the adjusting handle and the Barbell handle with bolts as shown.

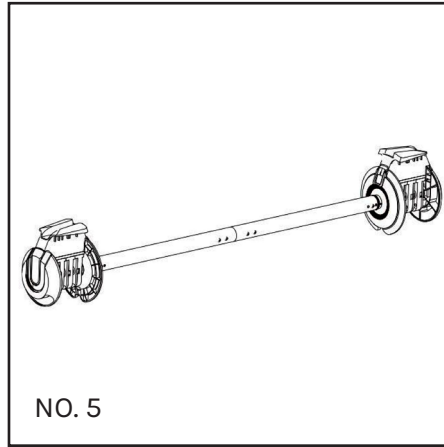

In the same way, install the other adjusting handle to the Barbell handle and complete the installation.

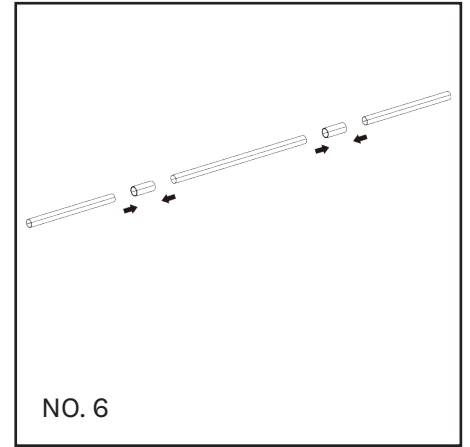

Install the connecting rod of base as shown. **Remark:** the longer connecting rods must be put on the middle position.

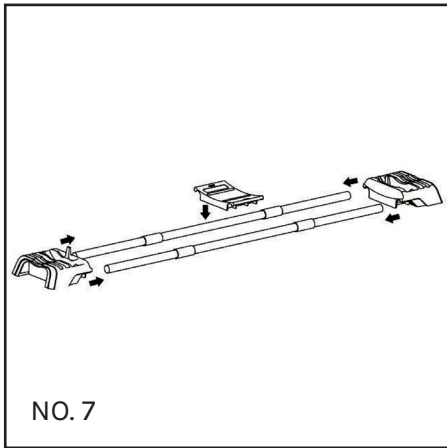

Connect the base connecting rod to the base as shown.

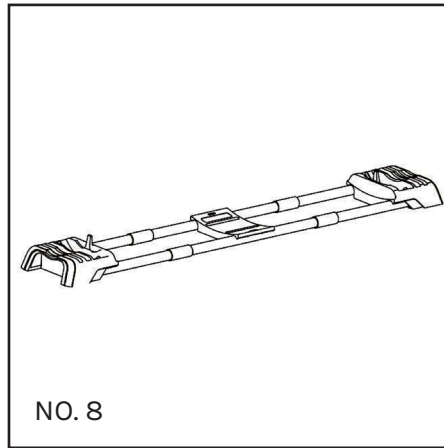

As shown in the picture: The base of Barbell is assembled.

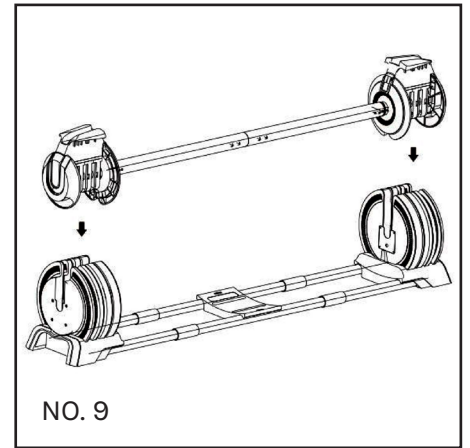

Put the handle into the base to complete the Barbell installation. **Remark:** The both sides of the handle should be put into the bell pieces at the same time.

## ASSEMBLE STEPS OF DUMBBELL

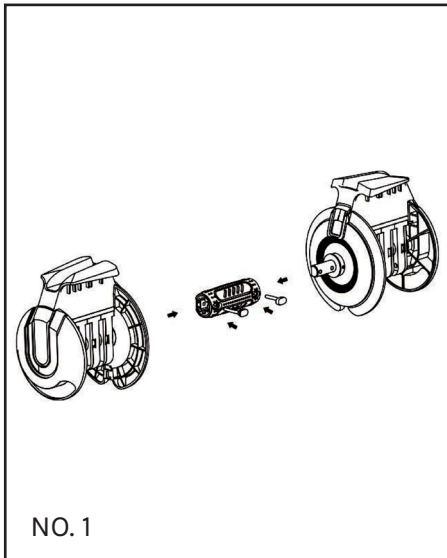

Install the adjusting handle with bolts as shown.

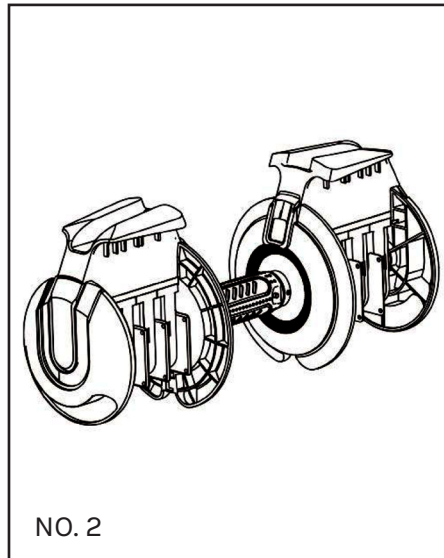

As shown in the picture:  
The handle of Dumbbell is assembled.

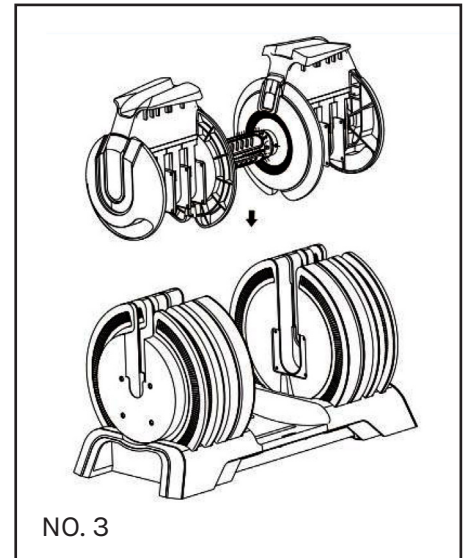

Put the handle into the base to complete the Dumbbell installation.

## ASSEMBLE STEPS OF KETTLEBELL

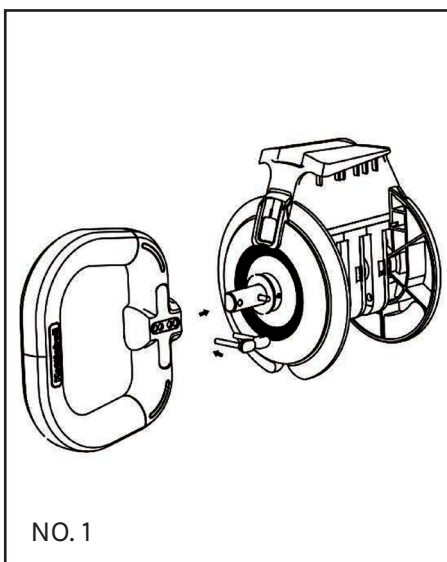

Install the adjusting handle and Kettlebell handle with bolts as shown.

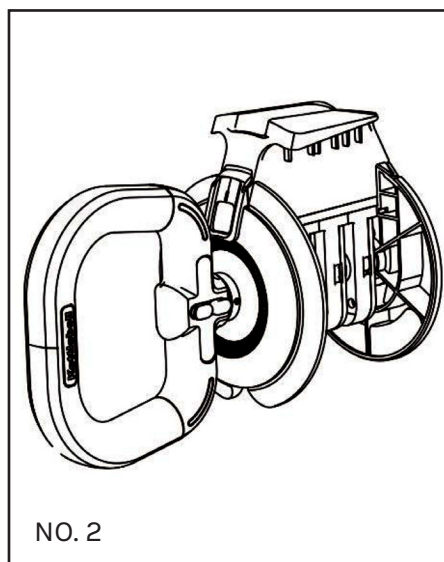

As shown in the picture:  
The handle of Kettlebell is assembled.

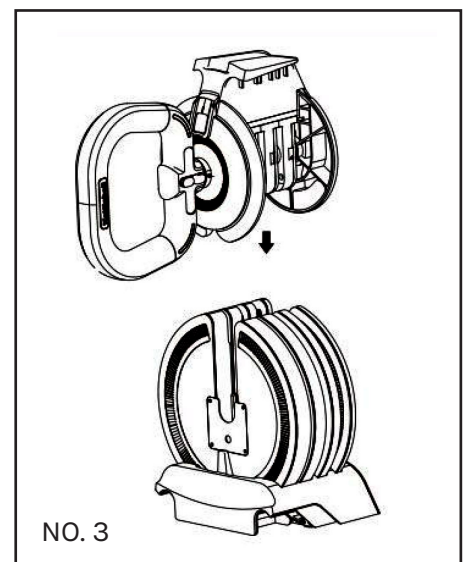

Put the handle into the base to complete the Kettlebell installation.

# VI. EXERCISE GUIDE

---

## ⚠ PLEASE NOTE:

Before beginning any exercise program, consult your physician. This is important especially if you are over the age of 45 or individuals with pre-existing health problems.

The pulse sensors are not medical devices. Various factors, including the user's movement, may affect the accuracy of heart rate readings. The pulse sensors are intended only as an exercise aid in determining heart rate trends in general.

---

Exercising is great way to control your weight, improving your fitness and reduce the effect of aging and stress. The key to success is to make exercise a regular and enjoyable part of your everyday life.

The condition of your heart and lungs and how efficient they are in delivering oxygen via your blood to your muscles is an important factor to your fitness. Your muscles use this oxygen to provide enough energy for daily activity. This is called aerobic activity. When you are fit, your heart will not have to work so hard. It will pump a lot fewer times per minute, reducing the wear and tear of your heart.

So as you can see, the fitter you are, the healthier and greater you will feel.

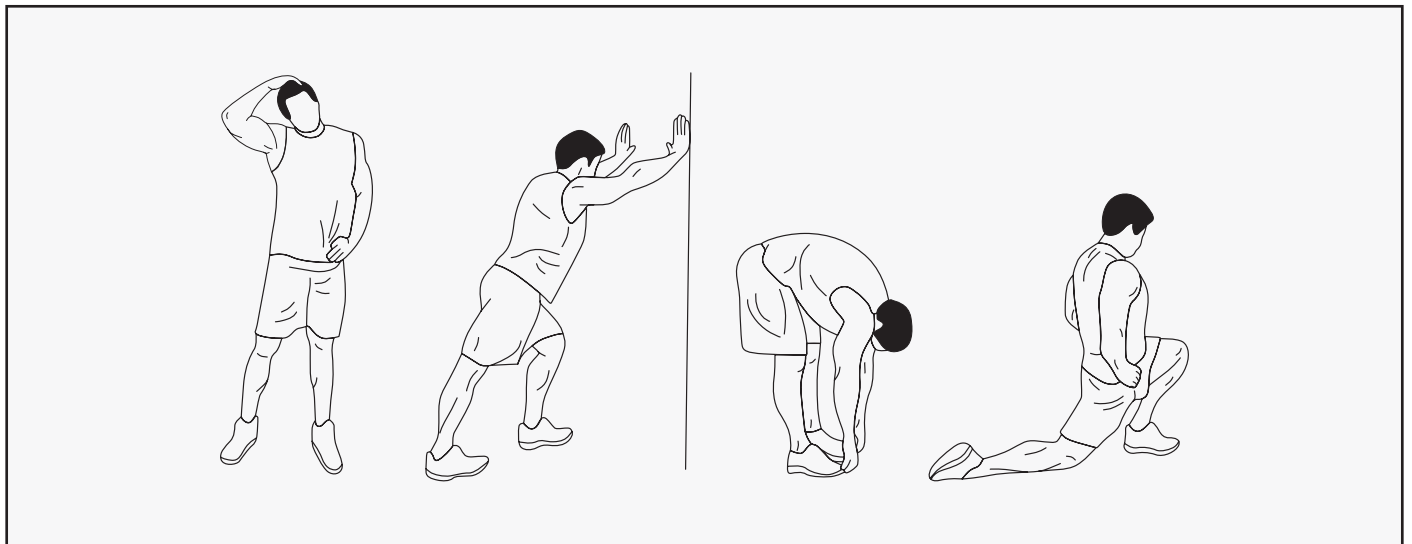

## WARM UP

Start each workout with 5 to 10 minutes of stretching and some light exercises. A proper warm-up increases your body temperature, heart rate and circulation in preparation for exercise. Ease into your exercise.

After warming up, increase the intensity to your desired exercise program. Be sure to maintain your intensity for maximum performance. Breathe regularly and deeply as you exercise.

## COOL DOWN

Finish each workout with a light jog or walk for at least 1 minute. Then complete 5 to 10 minutes of stretching to cool down. This will increase the flexibility of your muscles and will help prevent post-exercise problems.

## WORKOUT GUIDELINES

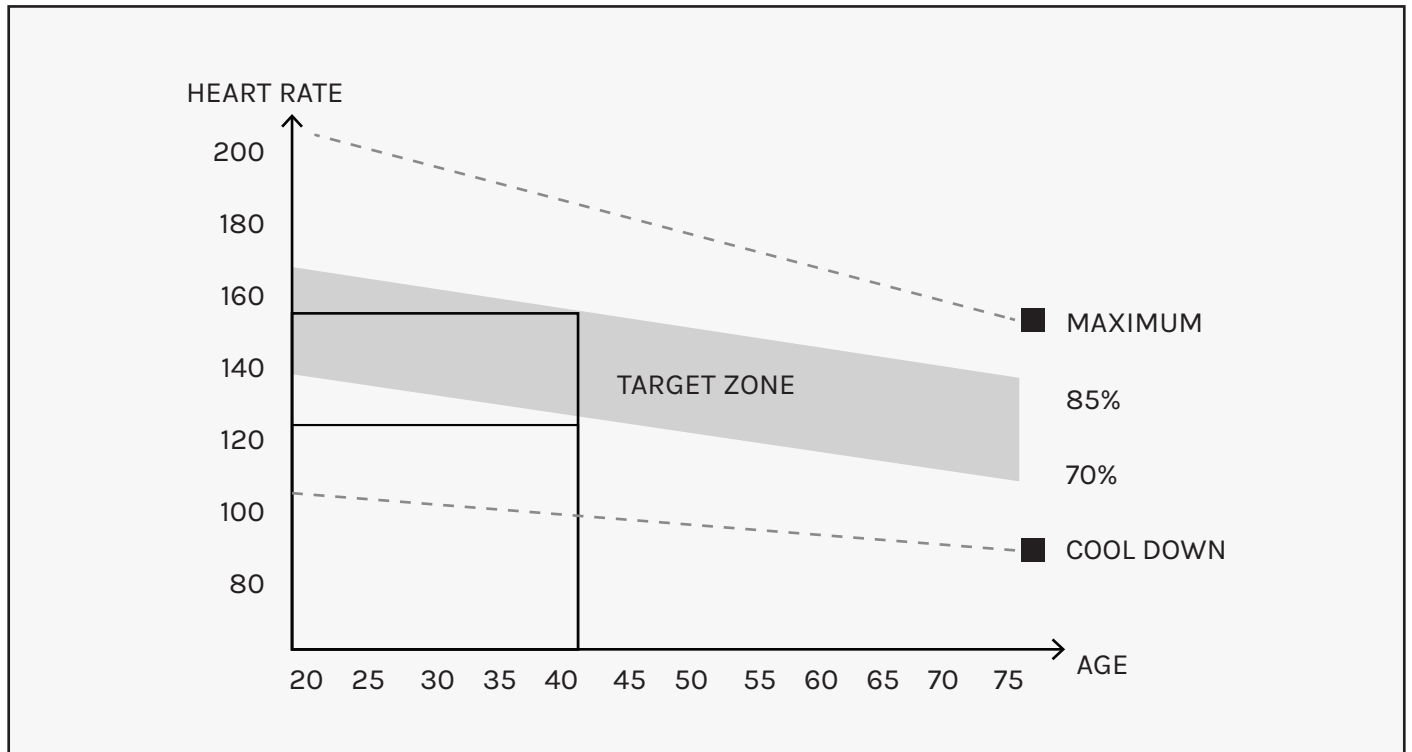

! This is how your pulse should behave during general fitness exercise. Remember to warm up and cool down for a few minutes.

The most important factor here is the amount of effort you put in. The harder and longer you work, the more calories you will burn.

# VII. WARRANTY

## AUSTRALIAN CONSUMER LAW

Many of our products come with a guarantee or warranty from the manufacturer. In addition, they come with guarantees that cannot be excluded under the Australian Consumer Law. You are entitled to a replacement or refund for a major failure and compensation for any other reasonably foreseeable loss or damage.

You are entitled to have the goods repaired or replaced if the goods fail to be of acceptable quality and the failure does not amount to a major failure. Full details of your consumer rights may be found at [www.consumerlaw.gov.au](http://www.consumerlaw.gov.au).

Please visit our website to view our full warranty terms and conditions:  
<http://www.lifespanfitness.com.au/warranty-repairs>

## WARRANTY AND SUPPORT

Any claim against this warranty must be made through your original place of purchase. Proof of purchase is required before a warranty claim may be processed.

If you have purchased this product from the Official Lifespan Fitness website, please visit <https://lifespanfitness.com.au/warranty-form>

For support outside of warranty, if you wish to purchase replacement parts or request a repair or service, please visit <https://lifespanfitness.com.au/warranty-form> and fill in our Repair/Service Request Form or Parts Purchase Form.

Scan this QR code with your device to go to [lifespanfitness.com.au/warranty-form](https://lifespanfitness.com.au/warranty-form)







***CORTEX***<sup>®</sup>

[WWW.LIFESPANFITNESS.COM.AU](http://WWW.LIFESPANFITNESS.COM.AU)