

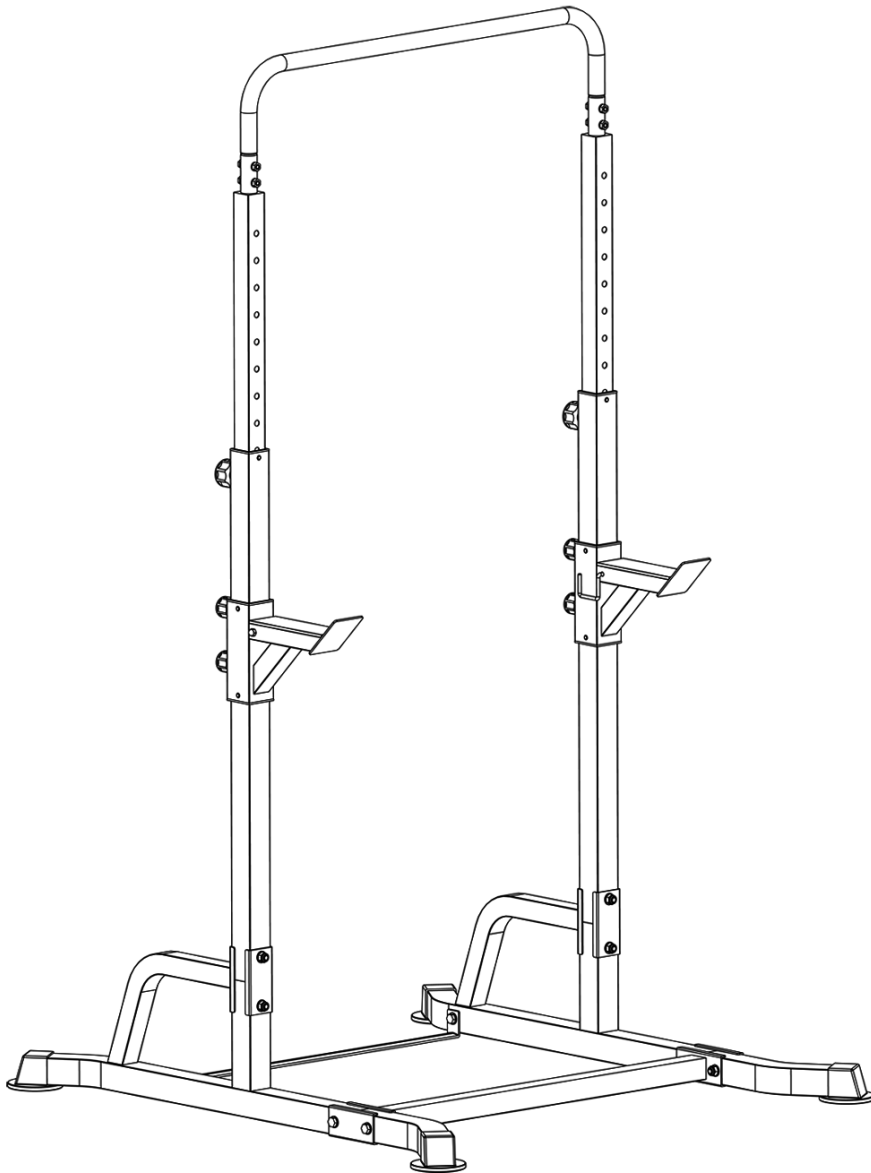

# GBH-220 BENCH & CHIN UP RACK OWNER'S MANUAL



Product may vary slightly from the item pictured due to model upgrades

**Read all instructions carefully before using this product. Retain this owner's manual for future reference.**

# TABLE OF CONTENTS

1. IMPORTANT SAFETY INSTRUCTIONS	3
2. CARE INSTRUCTIONS	4
3. PARTS LIST	5
4. ASSEMBLY INSTRUCTIONS	7
5. PRODUCT ADVICE	13
6. WARRANTY	14

# 1. IMPORTANT SAFETY INSTRUCTIONS

**WARNING** - Read all instructions before using this product.

Please keep this manual with you at all times

- a. It is important to read this entire manual before assembling and using the equipment. Safe and effective use can only be achieved if the equipment is assembled, maintained and used properly.

Please note: It is your responsibility to ensure that all users of the equipment are informed of all warnings and precautions.

- b. Before starting any exercise program, you should consult your doctor to determine if you have any medical or physical conditions that could put your health and safety at risk or prevent you from using the equipment properly. Your doctor's advice is essential if you are taking medication that affects your heart rate, blood pressure or cholesterol level.
- c. Be aware of your body's signals. Incorrect or excessive exercise can damage your health. Stop exercising if you experience any of the following symptoms: pain, tightness in your chest, irregular heartbeat, and extreme shortness of breath, lightheadedness, dizziness or feelings of nausea. If you do experience any of these symptoms, you should consult your doctor before continuing with your exercise program.
- d. Keep children and pets away from the equipment. This equipment is designed for adult use only.
- e. Use the equipment on a solid, flat level surface with a protective cover for your floor or carpet. To ensure safety, the equipment should have at least 2 meters of free space around it.
- f. Before using the equipment, check that the nuts and bolts are securely tightened. If you hear any unusual noises coming from the equipment during use and assembly, stop immediately. Do not use the equipment until the problem has been rectified.
- g. Wear suitable clothing while using the equipment. Avoid wearing loose clothing that may get caught in the equipment or that may restrict or prevent movement.
- h. This equipment is designed for indoor and family use only
- i. Care must be taken when lifting or moving the equipment so as not to injure your back.
- j. Always keep this instruction manual and assembly tools at hand for reference.
- k. The equipment is not suitable for therapeutic use.

## 2. CARE INSTRUCTIONS

- Lubricate moving joints with silicon spray after periods of usage
- Be careful not to damage plastic or metal parts of the machine with heavy or sharp objects
- The machine can be kept clean by wiping it down using dry cloth

### 3. PARTS LIST

NO.	DESCRIPTION	QTY
1	Left Side bottom tube	1
2	Right Side bottom tube	1
3	Bottom Extension tube	2
4	Upright main tube	2
5	Connection Bar	1
6	Connection Metal sheet	1
7	Chin-up bar	1
8	Height adjustable tube	2
9	Safety bar	2
10	Metal plate	4
11	End Cap	4
12	Bolt M10x70mm	8

NO.	DESCRIPTION	QTY
13	Bolt M8x40mm	4
14	Bolt M10x20mm	4
15	Washer M10	18
16	Locking Nut M10	8
17	Washer M8	4
18	Nut M8	4
19	Barbell Lock hook (pair)	1
20	Cap Nut M6	2
21	Bigger Spring Knob	2
22	Spring Knob	4
23	Wrench	2

#### Main Parts

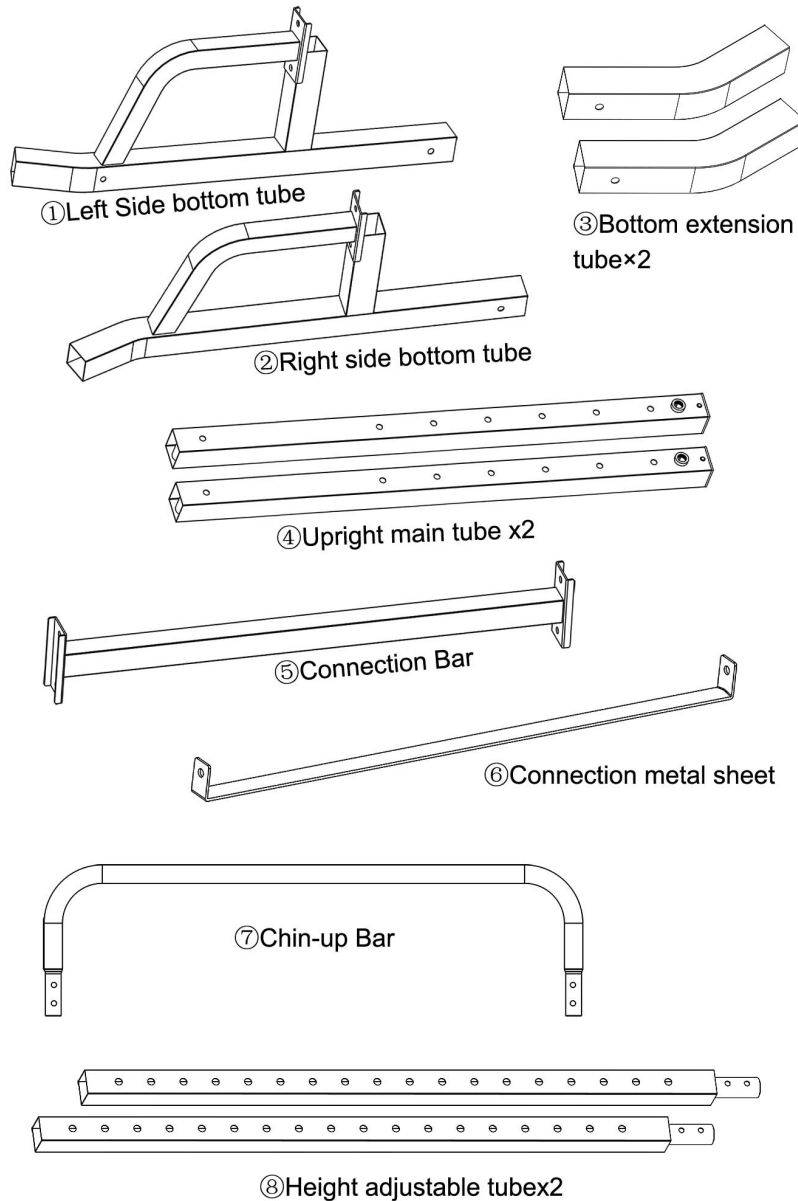

# Accessories parts

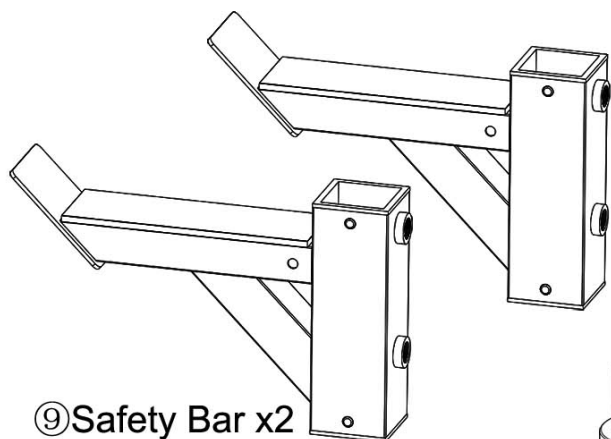

⑨ Safety Bar x2

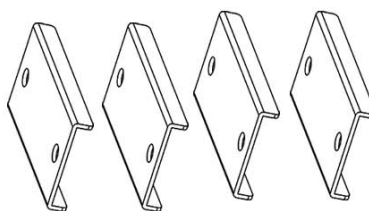

⑩ Metal plate x4

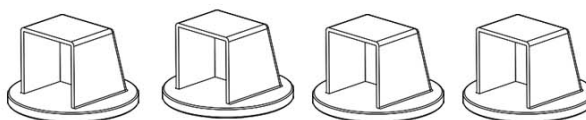

⑪ End cap x4

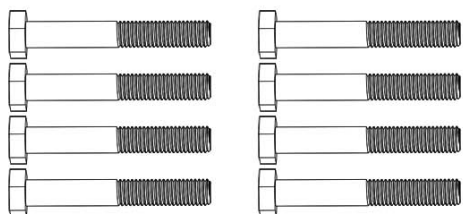

⑫ Bolt M10x70 8pcs

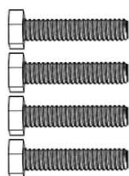

⑬ Bolt M8x40 4pcs

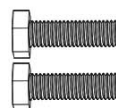

⑭ Bolt M10x20 2pcs

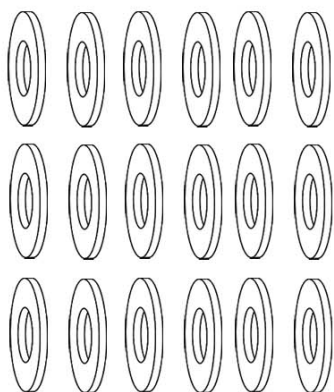

⑮ Washer  $\varnothing 10$  x18pcs

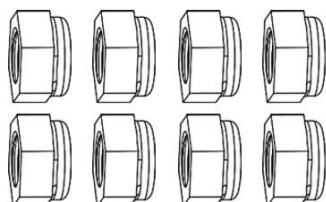

⑯ Locking Nut M10 x8pcs

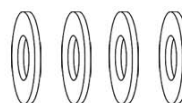

⑰ Washer  $\varnothing 8$  x4pcs

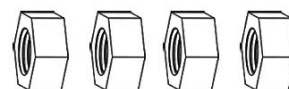

⑱ Nut M8 x4pcs

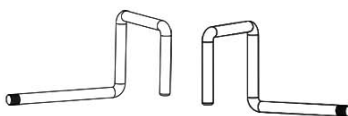

⑲ Barbell Lock hook x1 pair

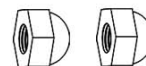

⑳ Cap Nut M6 x2pcs

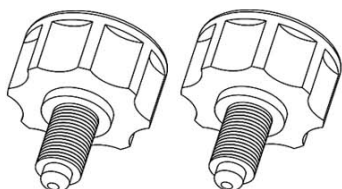

㉑ Bigger Spring Knob x2pcs

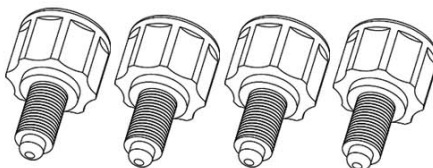

㉒ Spring Knob x4pcs

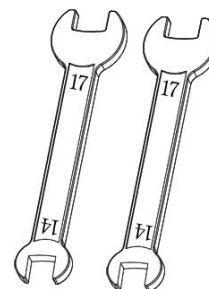

㉓ Wrench x2pcs

## 4. ASSEMBLY INSTRUCTIONS

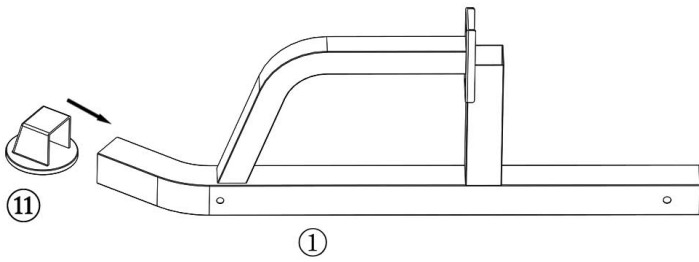

### Step 1:

Assembly (11) end cap onto (1) left bottom tube and (2) right bottom tube.

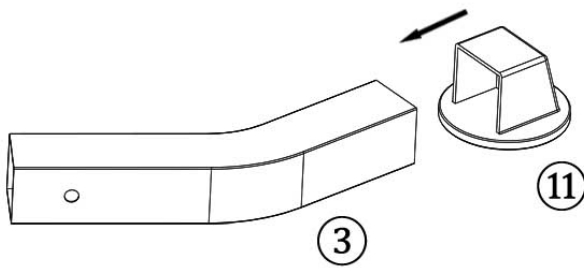
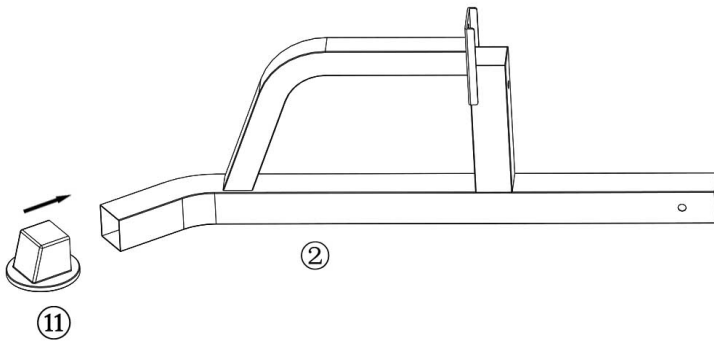

### Step 2:

Assembly (3) bottom extension tube with (11) end cap.

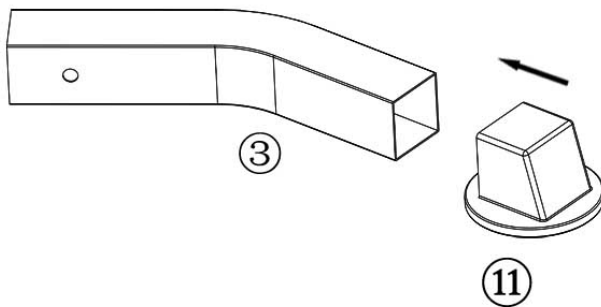

**Step 3:**

Assembly (5) connection bar onto main frame with (10) metal plate by using:

- (12) bolt M10\*70mm 4pcs
- (15) washer M10 8 pcs
- (16) locking nut M10 4 pcs

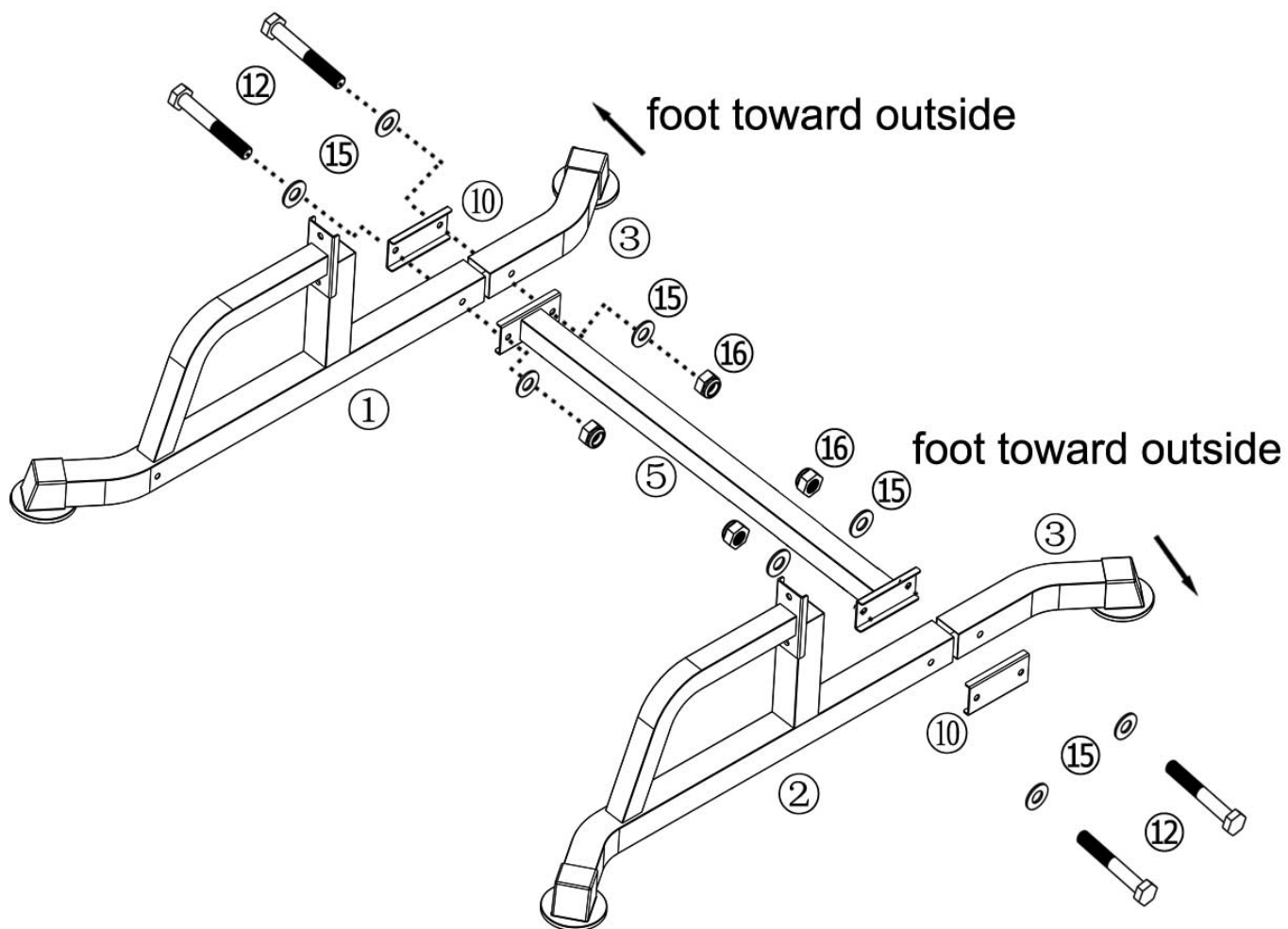

**Step 4:**

Assembly (6) connection metal sheet on main frame by using:

- (14) Bolt M10\*20mm 2pcs
- (15) washer M10 2 pcs

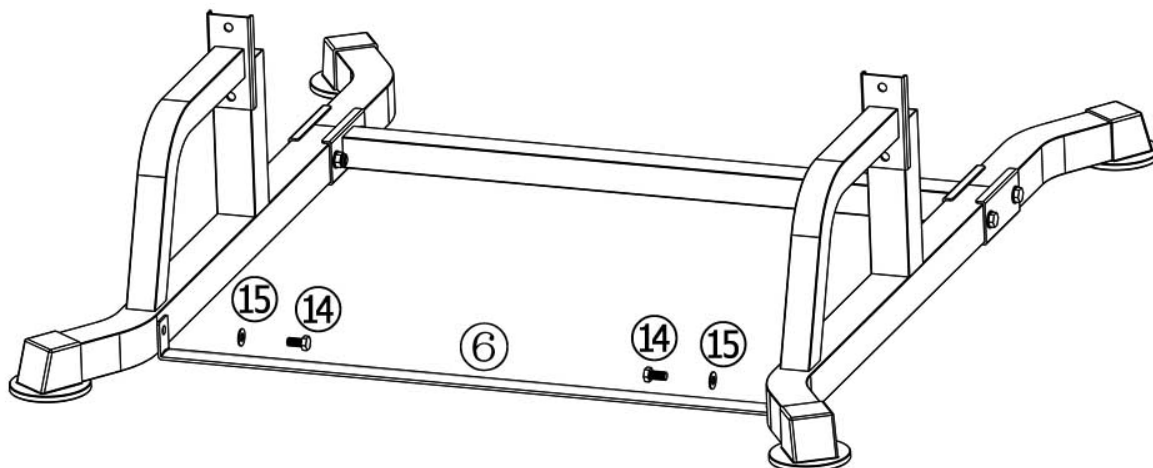



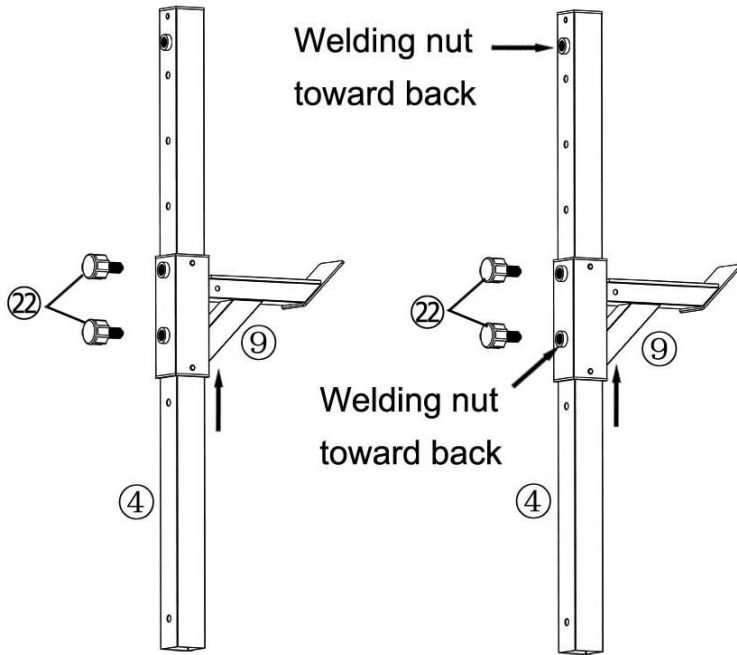

**Step 5:**

Assembly (4) upright main tube with (9) safety bar by using:

- (22) spring knob 4pcs

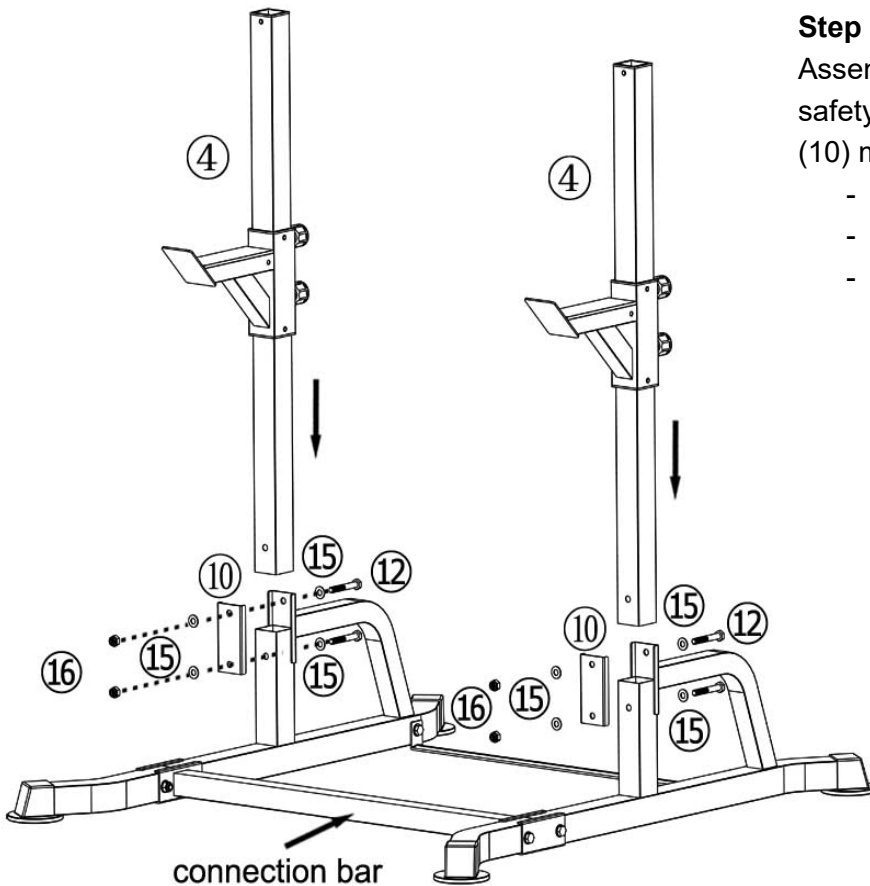
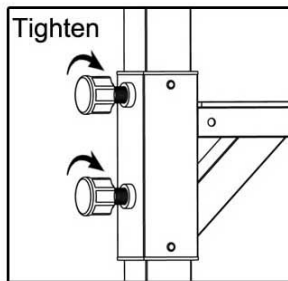

**Step 6:**

Assembly step 5 upright main tube and safety bar set onto main bottom frame with (10) metal plate by using:

- (12) bolt M10x70mm 4pcs
- (15) washer M10 8pcs
- (16) locking nut M10 4pcs

**Step 7:**

Put (8) height adjustable tube onto (4) upright main tube with (21) bigger spring knob 2pcs.

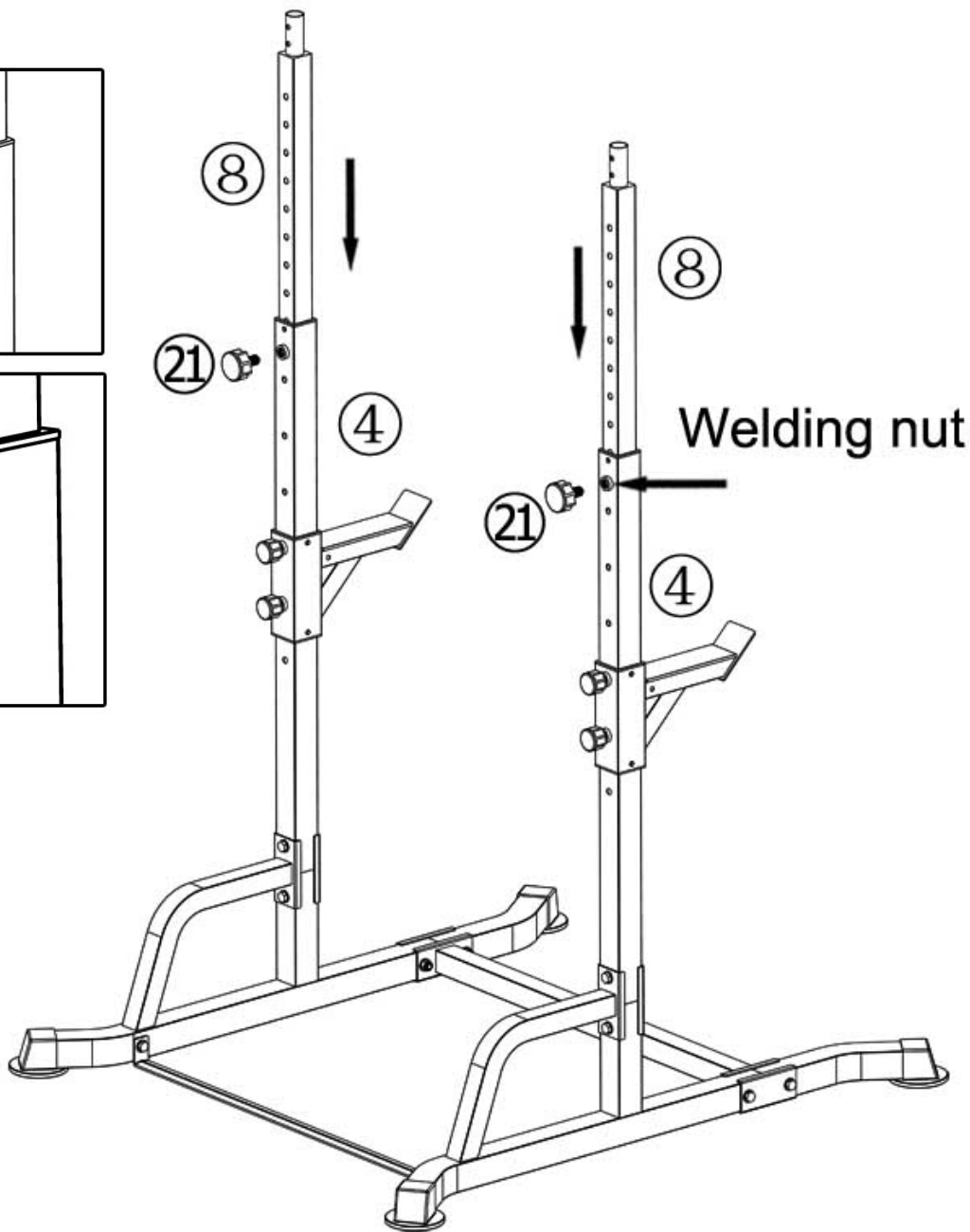
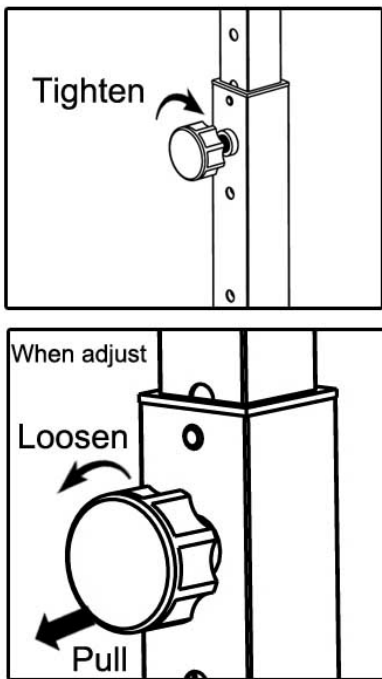

**Step 8:**

Assemble (7) chin up bar onto (8) onto (8) height adjustable tube by using:

- (13) bolt M8x40mm 4pcs
- (17) washer M8 8pcs
- (18) nut m8 4pcs

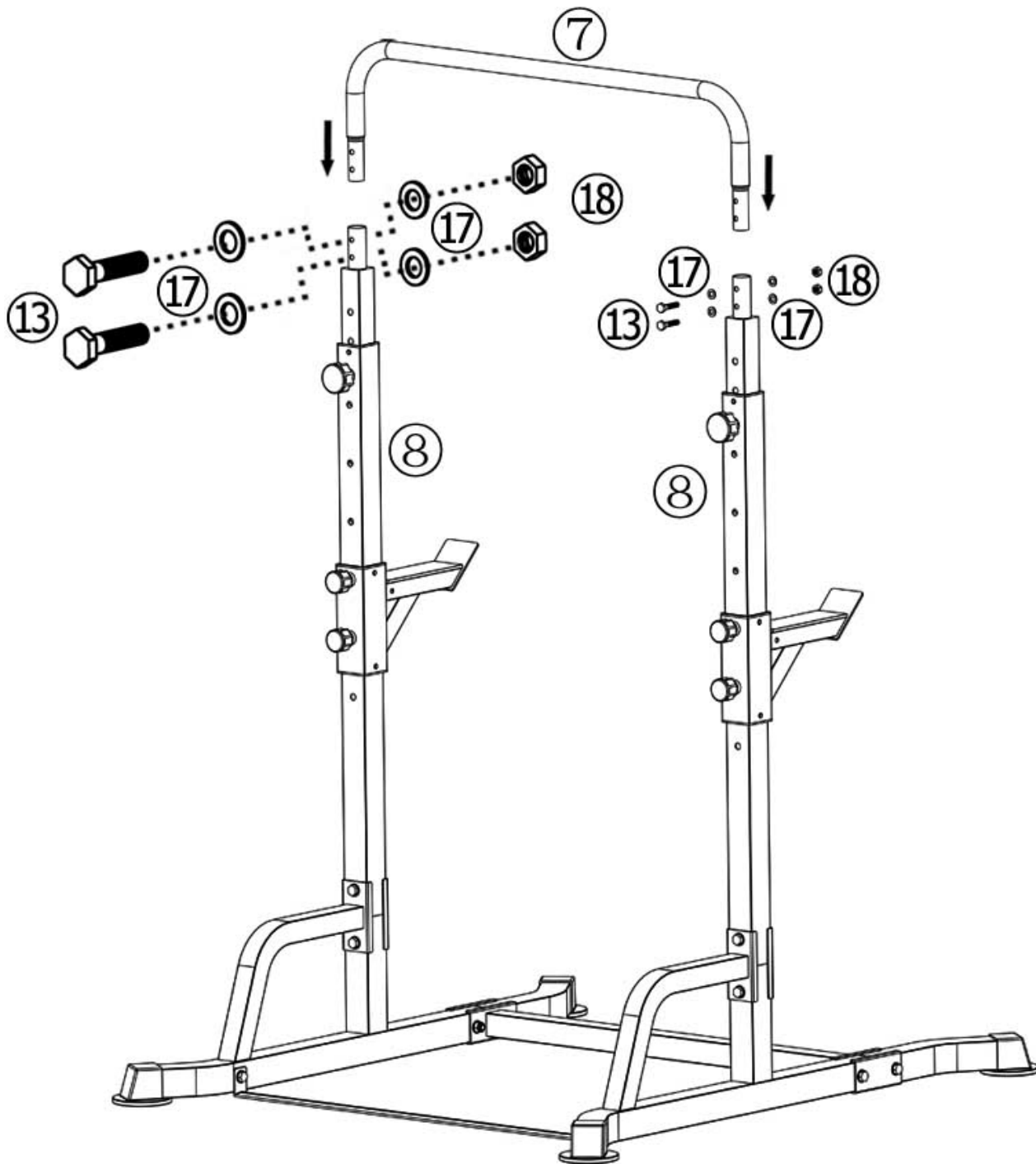

**Step 9:**

Assemble (19) barbell lock hook (pair) onto (9) safety bar by using (20) cap nut M6 2pcs.

Note: opening hook toward to spring knob is correct.

**Usage for barbell lock hook**

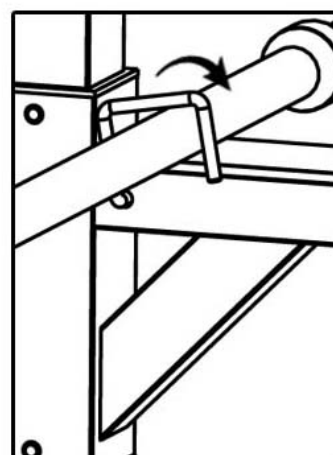
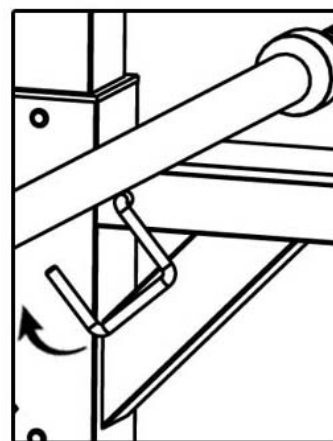
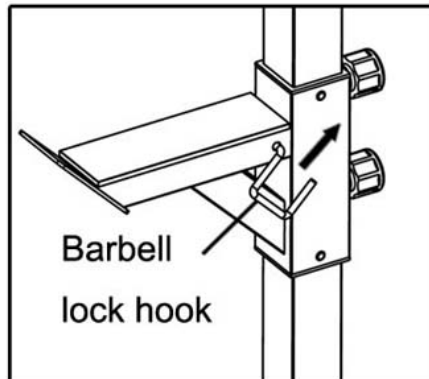
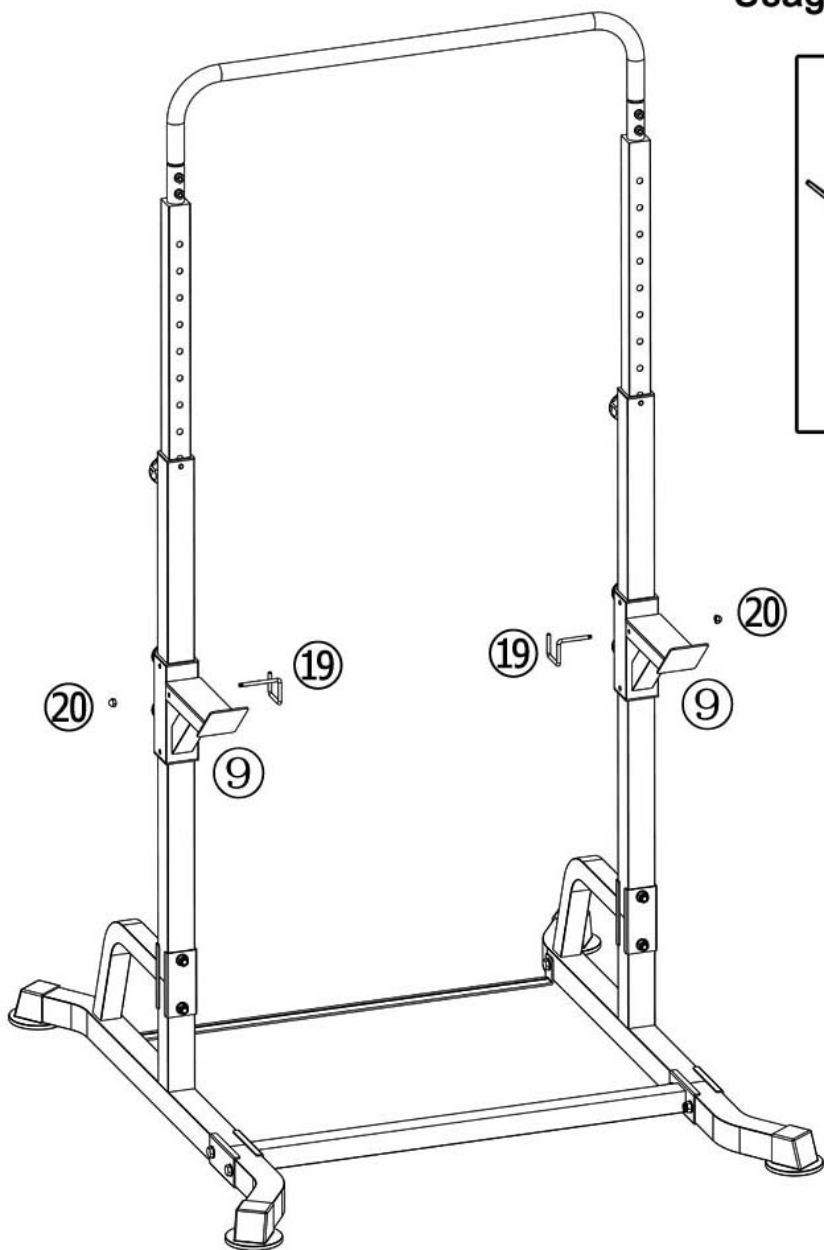

## 5. PRODUCT ADVICE

1. Spring knob must be assembled properly so there is no gap.

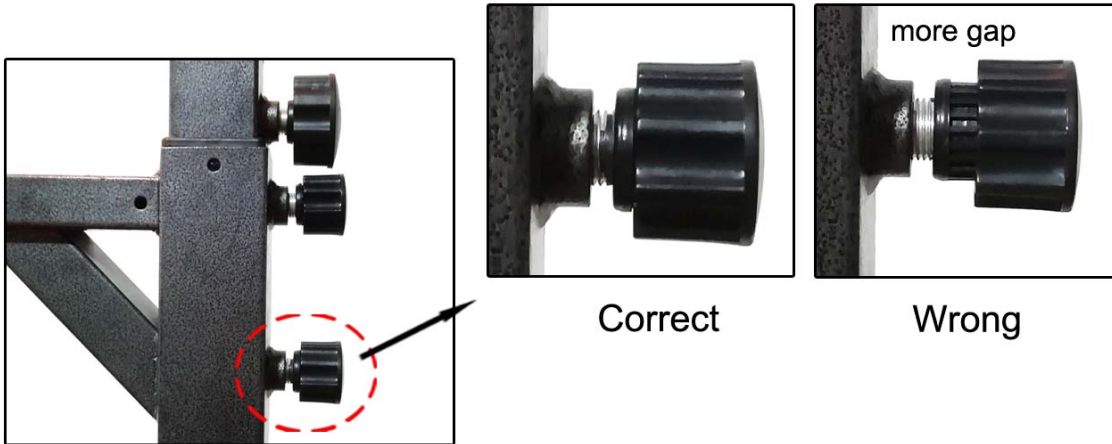

2. Metal sheet side is for chin up exercise and can also be used for bench press. (On step 6 the safety bars can be assembled facing the other side)
3. Connection bar side can only be use for bench exercise. (Note: It is recommended to do the chin up on the metal sheet section, so you do not stand on the connection bar as you come down.)



Metal sheet side is for Chin up exercise



Connection bar side is for Bench press exercise

## 6. WARRANTY

### AUSTRALIAN CONSUMER LAW

*Many of our products come with a guarantee or warranty from the manufacturer. In addition, they come with guarantees that cannot be excluded under the Australian Consumer Law. You are entitled to a replacement or refund for a major failure and compensation for any other reasonably foreseeable loss or damage.*

*You are entitled to have the goods repaired or replaced if the goods fail to be of acceptable quality and the failure does not amount to a major failure. Full details of your consumer rights may be found at [www.consumerlaw.gov.au](http://www.consumerlaw.gov.au)*

Please visit our website to view our full warranty terms and conditions:

<http://www.lifespanfitness.com.au/warranty-repairs>

### **Warranty and Support:**

Please email us at [support@lifespanfitness.com.au](mailto:support@lifespanfitness.com.au) for all warranty or support issues.

For all warranty or support related enquiries an email must be sent before contacting us via any other means.