

LSG

GBN-006 14 Level FID Bench

USER MANUAL

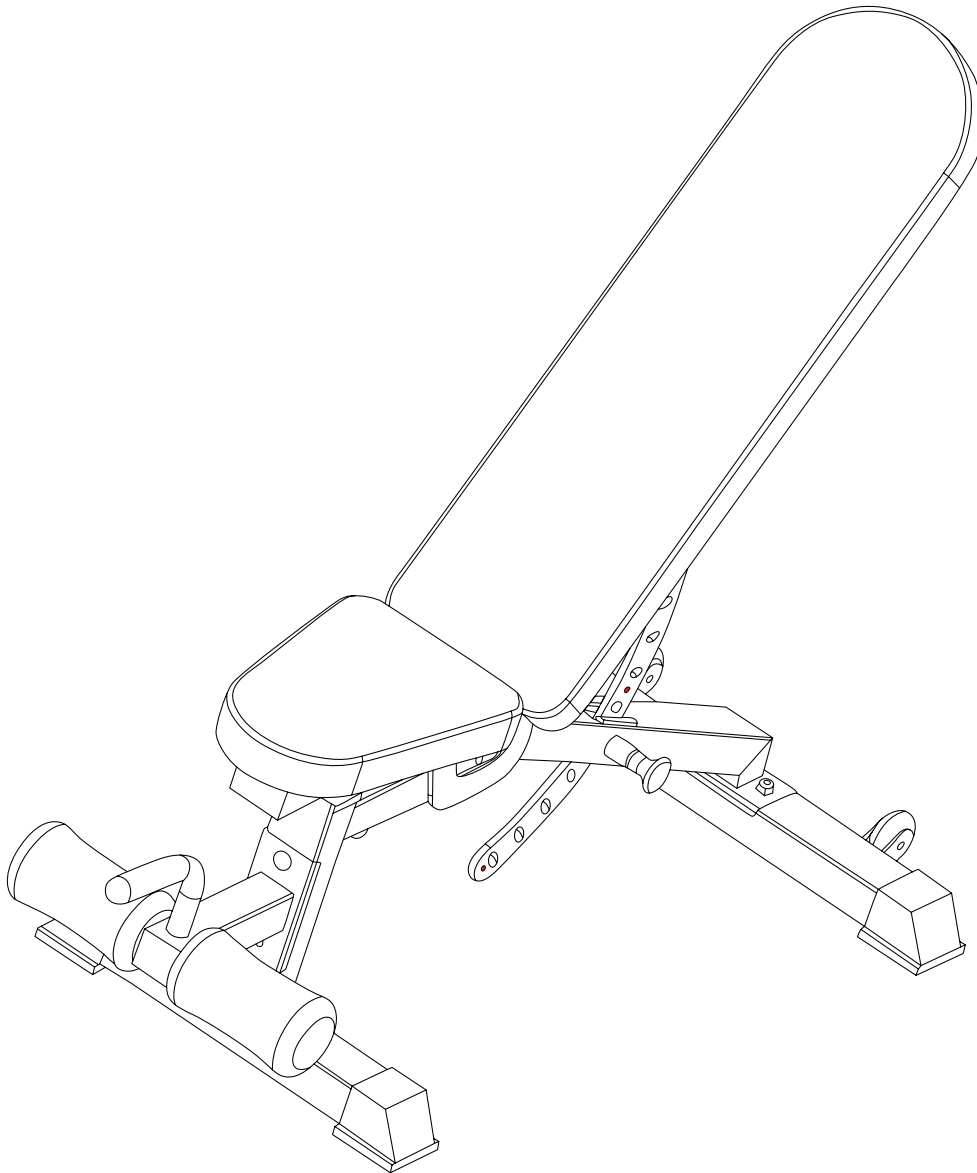

Product may vary slightly from the item pictured due to model upgrades.



**Read all instructions carefully before using this product.
Retain this owner's manual for future reference.**

NOTE:

This manual may be subject to updates or changes. Up to date manuals are available through our website at www.lsgfitness.com.au



TABLE OF CONTENTS

- I. Important Safety Instructions 03
- II. Care Instructions 04
- III. Assembly Instructions 05
- IV. Exercise Guide 08
- V. Warranty 10

I. IMPORTANT SAFETY INSTRUCTIONS



WARNING: Read all instructions before using this machine.

- Install the product on a flat level surface.
- Place your unit on a solid, level surface when in use.
- Never allow children on or near the machine.
- Keep hands away from all moving parts.
- Never drop or insert any object into any openings.
- Care must be taken when lifting or moving the equipment so as not to injure your back. Always use proper lifting techniques and/or seek assistance if necessary.
- Keep children and pets away from the machine at all times. DO NOT leave children unattended in the same room with the machine.
- Only 1 person at a time should use the machine.
- If the user experiences dizziness, nausea, chest pain, or any other abnormal symptoms, STOP the workout at once. CONSULT A PHYSICIAN IMMEDIATELY
- Do not use the machine near water or outdoors.
- Keep hands away from all moving parts.
- Always wear appropriate workout clothing when exercising. DO NOT wear robes or other clothing that could become caught in the machine. Running or aerobic shoes are also required when using the machine.
- Use the machine only for its intended use as described in this manual. DO NOT use attachments not recommended by the manufacturer.
- Do not place any sharp objects around the machine.
- Disabled person should not use the machine without a qualified person or physician in attendance.
- Never operate the machine if the machine is not functioning properly.
- A spotter is recommended during exercise.

II. CARE INSTRUCTIONS

- Lubricate moving joints with silicon spray after periods of usage.
- Be careful not to damage plastic or metal parts of the machine with heavy or sharp objects.
- The machine can be kept clean by wiping it down using dry cloth.
- Check and adjust the tension of wire rope on a regular basis.
- Regularly check all moving parts and make sure there are signs of wear and damage, if any the use of the device must be stopped immediately and contact our after-sales department.
- During inspection, it is necessary to make sure that all bolts and nuts are completely fixed. If any bolt or nut connection is loosened, please re-tighten.
- Check weld for cracks.
- Failure to perform daily maintenance may result in personal injury or equipment damage.

III. ASSEMBLY INSTRUCTIONS

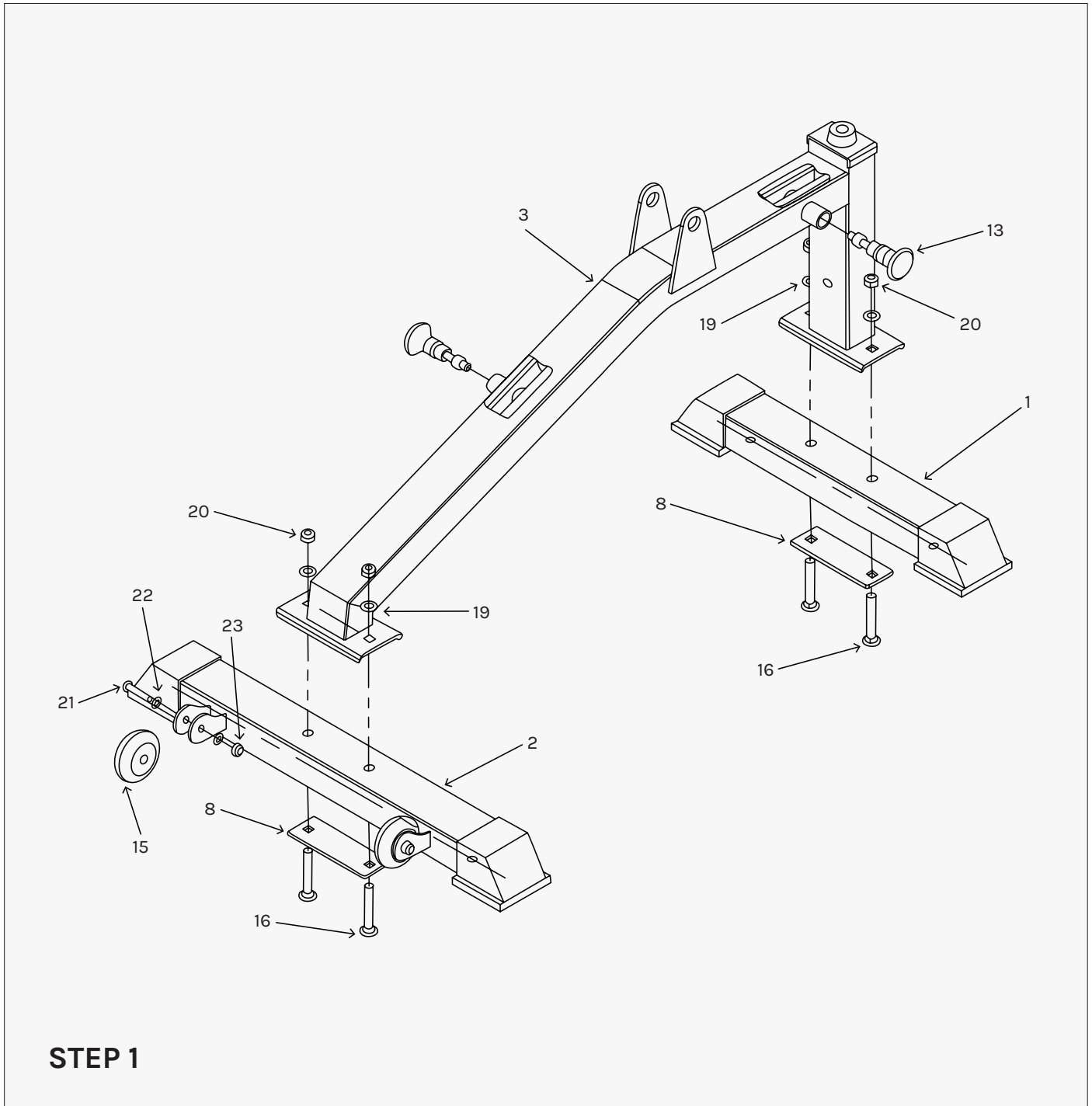

1. Use 16# (M10X70 carriage screw), 8# (connecting piece), 19# ($\Phi 10$ flat gasket), 20# (M10 anti-loosening mother) respectively to connect and fasten 3# (main frame) to 2# (rear sticking ground), 1# (front sticking ground), as shown. Then install 13# (pin welding) as shown in the two positions.

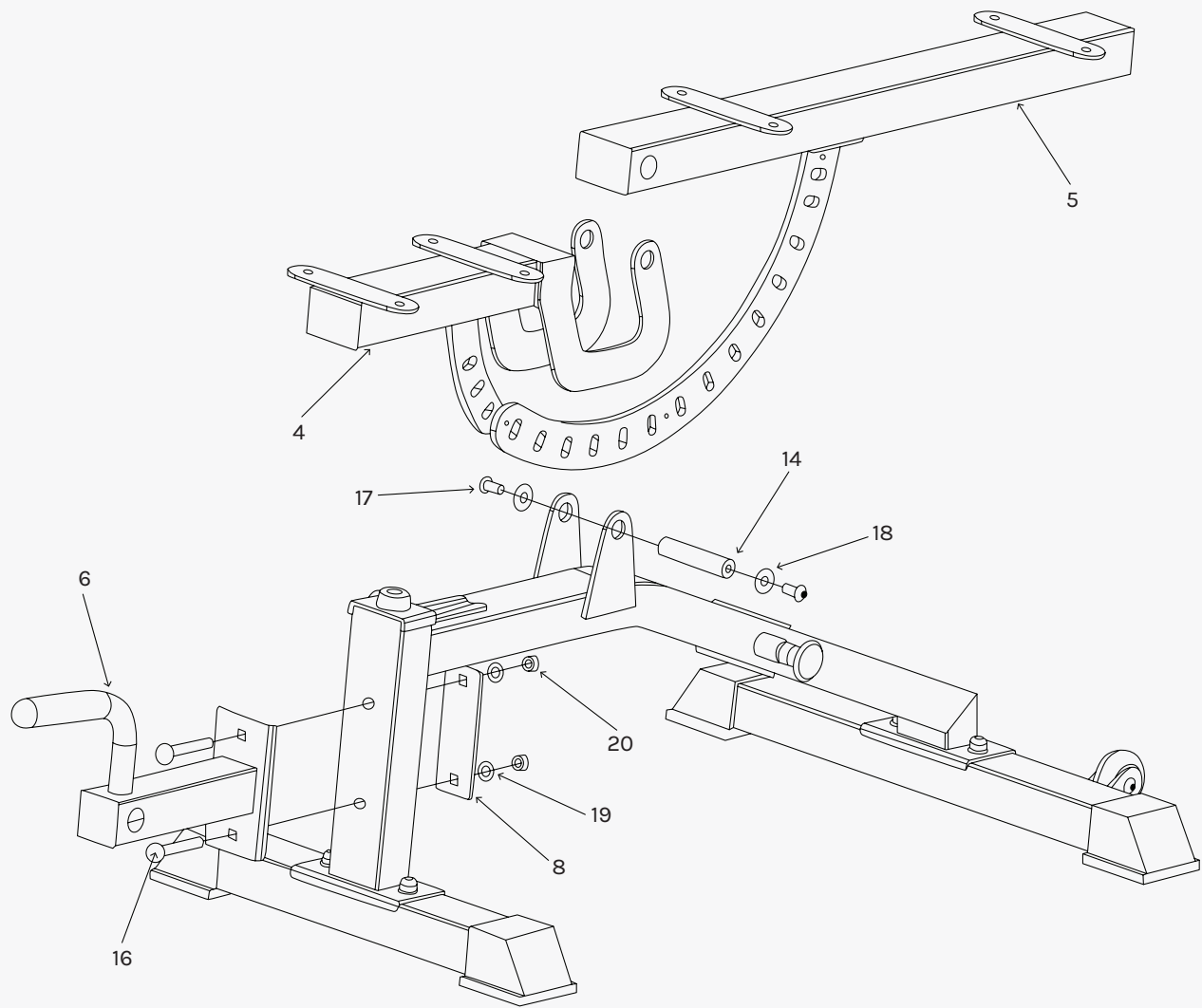

STEP 2

1. Use 16# (M10X70 carriage screw), 8# (connecting piece), 19# (Φ10 flat gasket), 20# (M10 anti loosening mother) to fix 6# (front pressing leg welding) on 3# (main frame) as shown.
2. Connect 5# (sitting back frame) with 4# (cushion frame) with 14# (connecting shaft), 17# (M10X20 disc head screw), 18# (Φ 10 enlarged flat gasket), as shown.

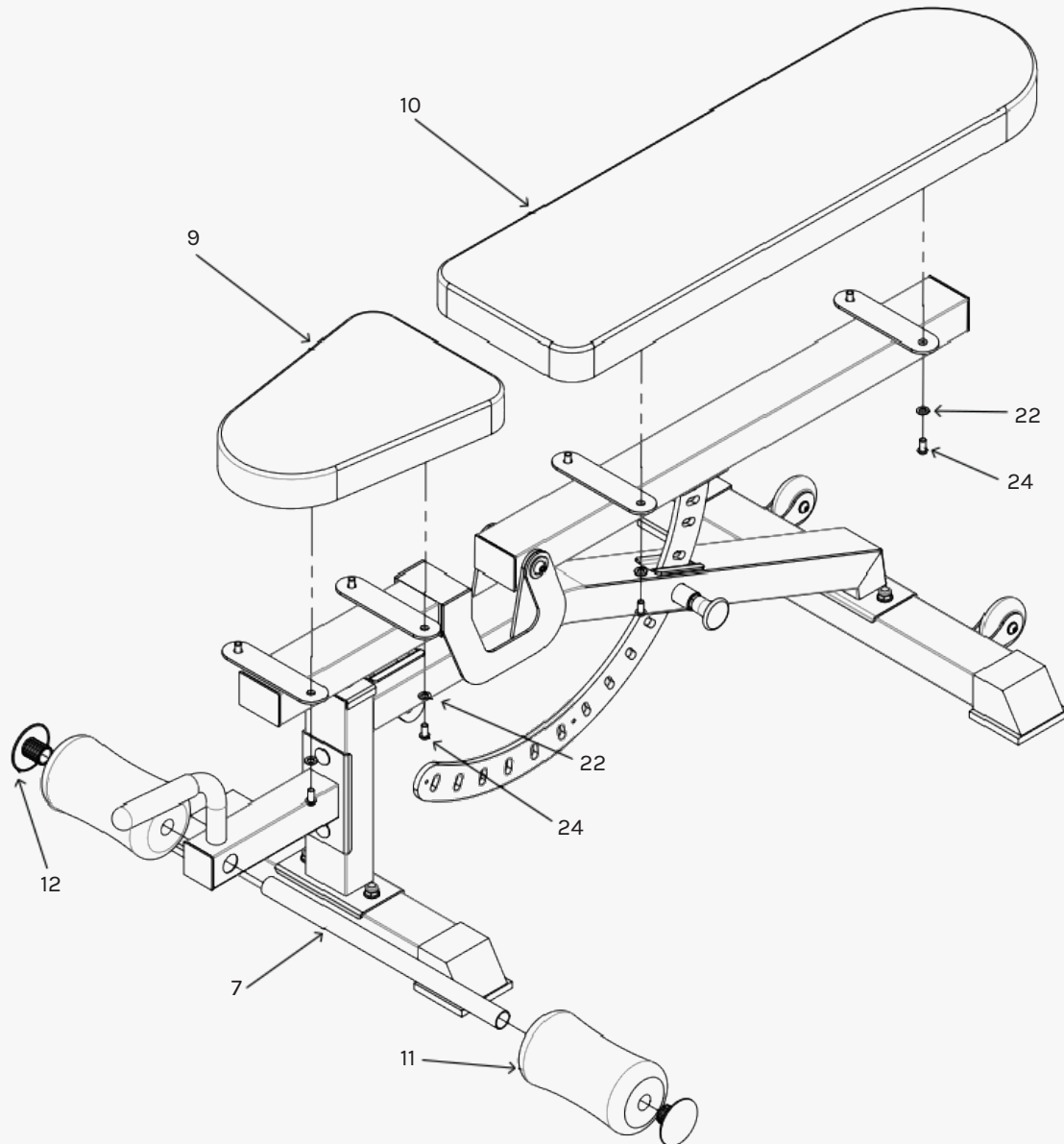

STEP 3

1. Use 24# (inner hexagonal M8X16) and 22# (Φ 8 gasket) to fix 10# (back cushion) to 5#. Use 24# (inner hexagonal M8X16) and 22# (Φ 8 gasket) to fix 9# (cushion) to 4#.
2. Put 7# (foam pipe) into 6# (front leg welding) and install 11# (bubble cotton) and 12# (bubble cotton plug) to fix both ends.

IV. EXERCISE GUIDE

⚠ PLEASE NOTE:

Before beginning any exercise program, consult your physician. This is important especially if you are over the age of 45 or individuals with pre-existing health problems.

The pulse sensors are not medical devices. Various factors, including the user's movement, may affect the accuracy of heart rate readings. The pulse sensors are intended only as an exercise aid in determining heart rate trends in general.

Exercising is great way to control your weight, improving your fitness and reduce the effect of aging and stress. The key to success is to make exercise a regular and enjoyable part of your everyday life.

The condition of your heart and lungs and how efficient they are in delivering oxygen via your blood to your muscles is an important factor to your fitness. Your muscles use this oxygen to provide enough energy for daily activity. This is called aerobic activity. When you are fit, your heart will not have to work so hard. It will pump a lot fewer times per minute, reducing the wear and tear of your heart.

So as you can see, the fitter you are, the healthier and greater you will feel.

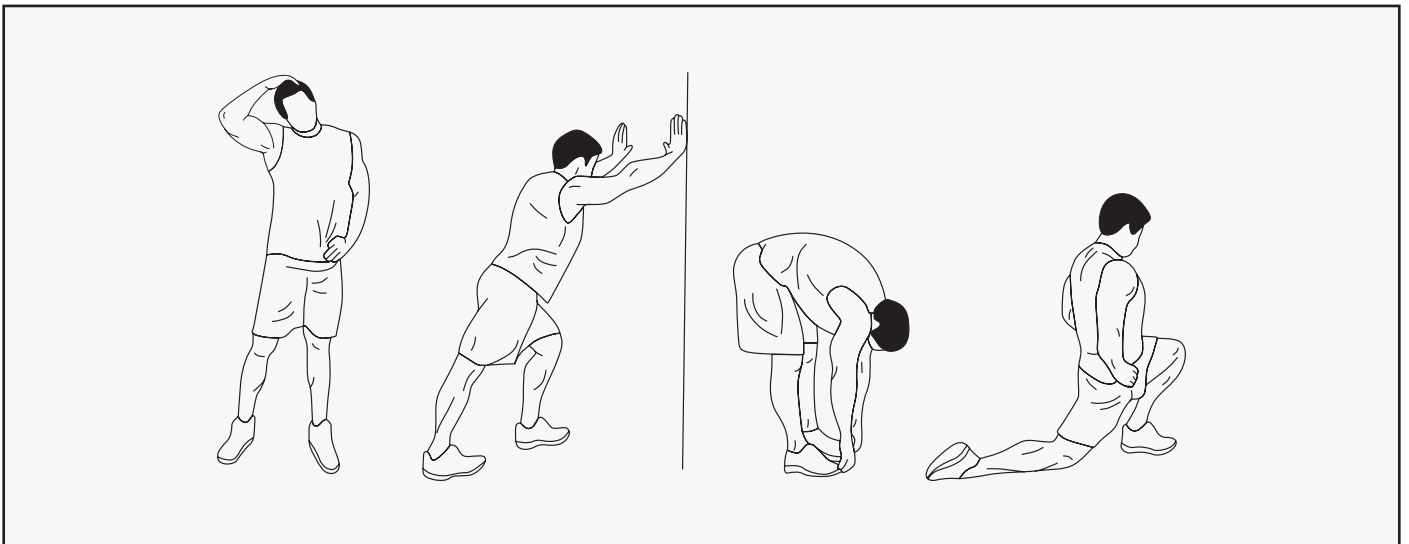

WARM UP

Start each workout with 5 to 10 minutes of stretching and some light exercises. A proper warm-up increases your body temperature, heart rate and circulation in preparation for exercise. Ease into your exercise.

After warming up, increase the intensity to your desired exercise program. Be sure to maintain your intensity for maximum performance. Breathe regularly and deeply as you exercise.

COOL DOWN

Finish each workout with a light jog or walk for at least 1 minute. Then complete 5 to 10 minutes of stretching to cool down. This will increase the flexibility of your muscles and will help prevent post-exercise problems.

WORKOUT GUIDELINES

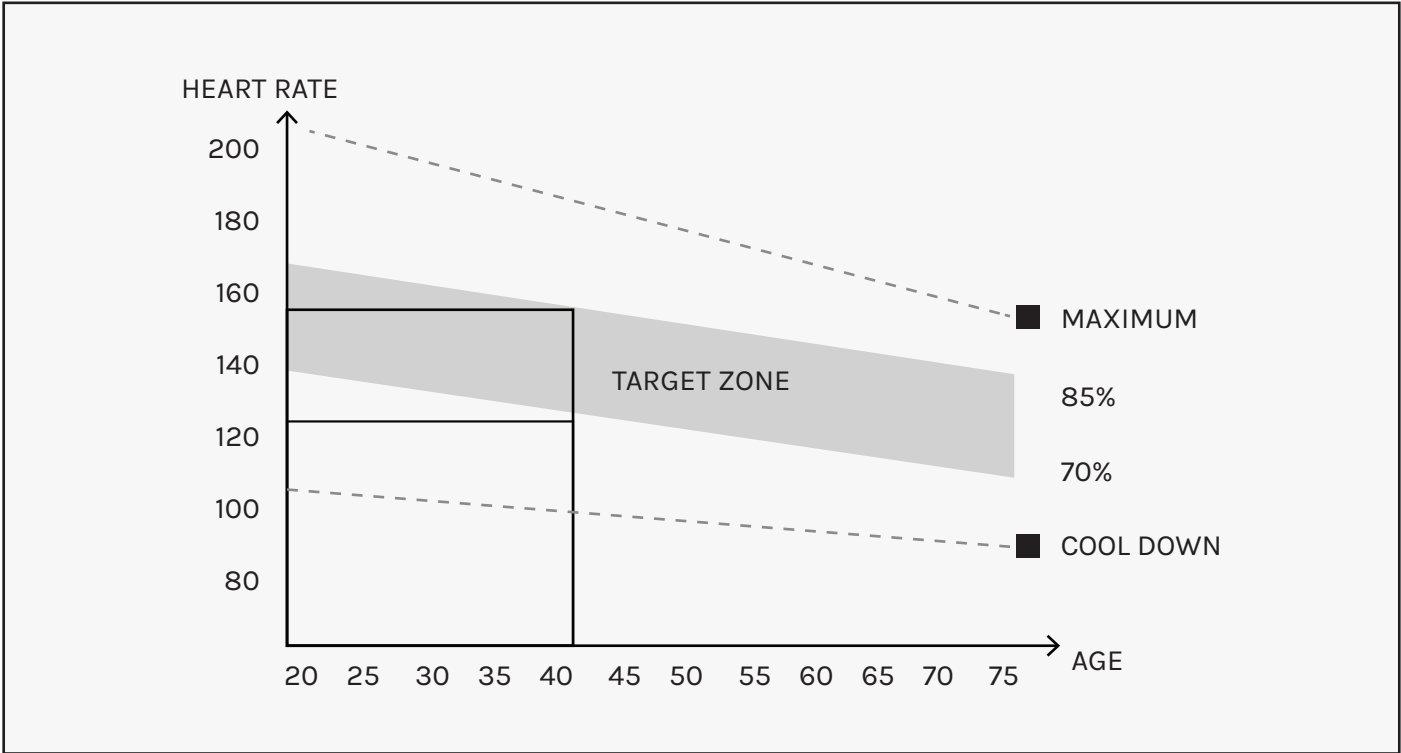

! This is how your pulse should behave during general fitness exercise. Remember to warm up and cool down for a few minutes.

V. WARRANTY

AUSTRALIAN CONSUMER LAW

Many of our products come with a guarantee or warranty from the manufacturer. In addition, they come with guarantees that cannot be excluded under the Australian Consumer Law. You are entitled to a replacement or refund for a major failure and compensation for any other reasonably foreseeable loss or damage.

You are entitled to have the goods repaired or replaced if the goods fail to be of acceptable quality and the failure does not amount to a major failure. Full details of your consumer rights may be found at www.consumerlaw.gov.au.

Please visit our website to view our full warranty terms and conditions:

<https://www.lsgfitness.com.au/pages/warranty>

WARRANTY AND SUPPORT

Please email us at support@lsgfitness.com.au for all warranty or support issues.

For all warranty or support related enquiries, please lodge a support ticket first by sending us an email.

LSG

WWW.LSGFITNESS.COM.AU