

# OMEGA Series RNC10 Roman Chair

## OWNER'S MANUAL

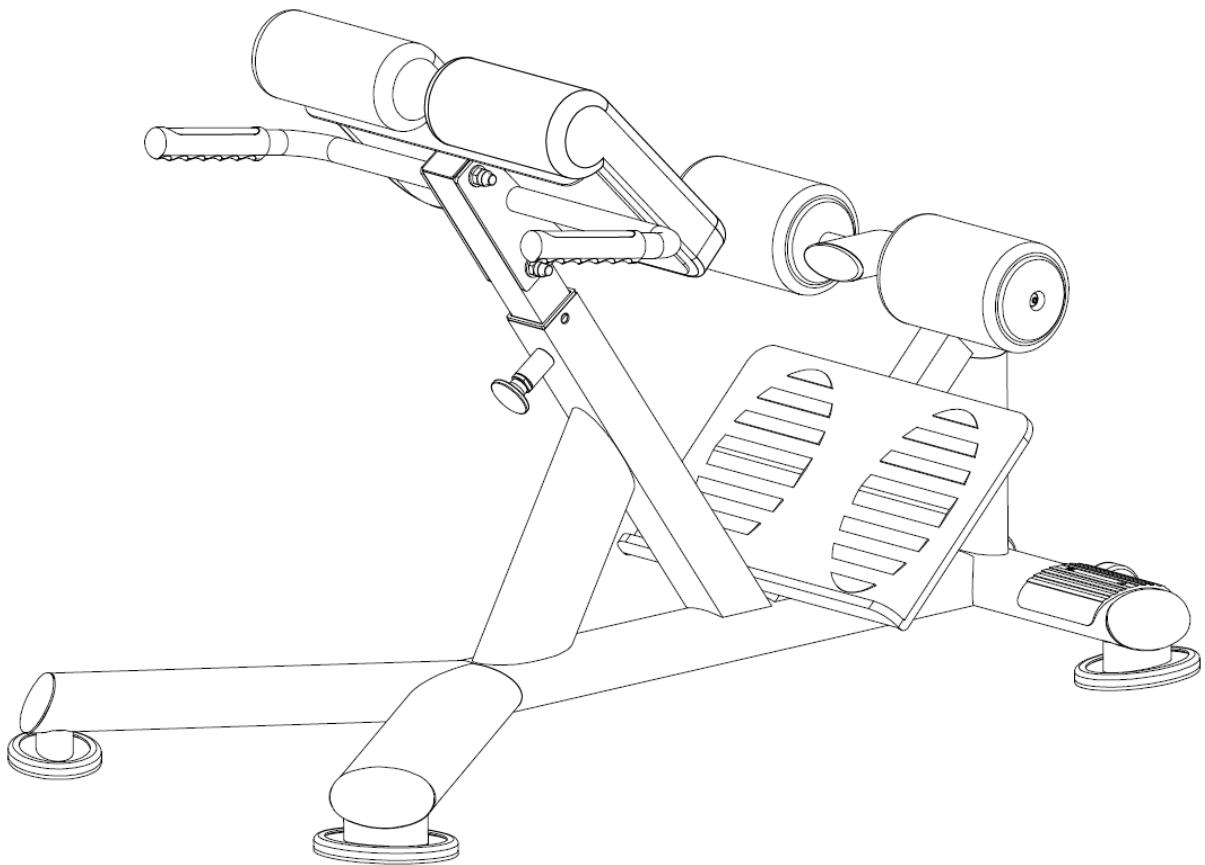

### IMPORTANT!

---

*Please read all instructions carefully before using this product.*

*Retain this manual for future reference.*

*The specifications of this product may vary slightly from the illustrations and are subject to change without notice.*

# WARNING, Safety & Maintenance

Be sure that all users carefully read and understand all warning, safety and maintenance info on this Owner's Manual or labels on the machine before each use. Failure to do so may result in death or serious injury.

It is imperative that you retain this Owner's Manual and be sure all warning labels are legible and intact.

If you have any questions about the operation, set up or maintenance of this machine please contact the local distributors or sales agents.

**THERE IS A RISK ASSUMED BY INDIVIDUALS WHO USE THIS TYPE OF EQUIPMENT. TO MINIMIZE RISK, YOU MUST FOLLOW THESE RULES:**

1. Inspect equipment before each workout. Check that all nuts, bolts, screws and pop pins are in place and fully tightened. Also, before use, check cables for signs of wear. Replace all worn parts immediately. Never use machine if any parts are damaged or missing. **FAILURE TO FOLLOW THESE RULES MAY RESULT IN SERIOUS INJURY.**
2. Keep clear of the cables and all moving parts when the machine is in use.
3. Always make sure all Snap Links are closed when doing any cable/pulley/strap exercises.
4. Exercise with care. Perform your exercises at a smooth moderate pace; never perform jerky or uncoordinated movements that may cause injury.
5. It is recommended that you should workout with a training partner.
6. Do not allow children or minors to play on or around this equipment.
7. If unsure of proper use of equipment, call your local distributor or agent.
8. **WARNING:** Consult your physician before starting your exercise program. For your own safety, do not begin any exercise program without proper instruction.

**WARNING** Safety and Maintenance of Cables

**IMPORTANT:** Cables are wear items. It is your responsibility to prevent unexpected breakage. **Cable inspection should be performed daily.** Inspect all cables, the nylon coating on all cables, and the area near the fitting at each end of each cable. **Replace any damaged or worn cable immediately.** Do not allow the machine to be used until damaged or worn cables are replaced. Using or allowing a machine to be used with a suspect cable can result in serious injury. See Owner's Manual for more information.

MAINTENANCE SCHEDULE		DAILY	WEEKLY
Check the function and integrity of the following components. As noted, inspect equipment before each workout. Replace all damaged, broken or worn components immediately.			
<b>Cables:</b>	Check tension, end fittings, and coating	√	
	Check that locking nut at weight stack is tight		√
<b>Upholstery:</b>	Wipe down and dry	√	
	Clean and condition		√
<b>Frame:</b>	Wipe down and dry	√	
	Polish / Wax		√
<b>Chrome:</b>	Wipe down and dry	√	
	Polish / Lubricate		√
<b>Nuts/ Bolts/ Fasteners:</b> Tighten and/ or adjust as needed			√
<b>Guide Rods:</b>	Lubricate and clean		√
<b>Linear Rods:</b>	Lubricate and clean		√
<b>Seat Sleeves:</b>	Lubricate and clean		√
<b>Adjustments/ Locking Pins/ Tightening Knobs</b>			√
<b>Weight Stack Pins</b>			√
<b>Warning Instruction Labels</b>			√
<b>Springs/ Pop Pins</b>		√	
<b>Anti Skid Surfaces</b>			√
<b>Hand Grips/ Rollers</b>			√
<b>MAX. USER WEIGHT 180Kgs</b>			

# Important Safety Instructions

Before beginning any fitness program, you should obtain a complete physical examination from your physician.

// est conseill e de subir un examen m edical complet avant d'entreprendre tout programme d'exercice. Si vous avez des  etourdissements ou des faiblesses, arr etez les exercices imm ediatement.

Antes de comenzar cualquier programa de ejercicios, deberias tener un examen fisico con su doctor.

---

## **WHEN USING EXERCISE EQUIPMENT, YOU SHOULD ALWAYS TAKE BASIC PRECAUTIONS, INCLUDING THE FOLLOWING:**

- Read all instructions before using the equipment. These instructions are written to ensure your safety and to protect the unit.
- **Do not remove any safety labels from the machine. MAX. USER WEIGHT: 180Kgs**
- Do not allow children on or near the equipment.
- Use the equipment only for its intended purpose as described in this guide. Do not use accessory attachments that are not recommended by the manufacturer. Such attachments might cause injuries.
- Wear proper exercise clothing and shoes for your workout, no loose clothing.
- Keep hands, limbs, loose clothing, and long hair well out of the way of all moving parts.
- Use care when getting on or off the unit.
- Do not overexert yourself or work to exhaustion.
- If you feel any pain or abnormal symptoms, stop your workout immediately and consult your physician.
- Never operate unit when it has been dropped or damaged. Return the equipment to a service center for examination and repair.
- Never drop or insert objects into any opening in the equipment.
- Always check the unit and its cables before each use. Make sure that all fasteners and cables are secure and in good working condition.
- Do not use the equipment outdoors or near water.

## **Personal Safety During Assembly**

- Before beginning assembly, please take the time to read the instructions thoroughly.
- Read each step in the assembly instructions and follow the steps in sequence. Do not skip ahead. If you skip ahead, you may learn later that you have to disassemble components and that you may have damaged the equipment.
- Assemble and operate the equipment on a solid, level surface. Locate the unit a few feet from the walls or furniture to provide easy access.
- The machine is designed for your enjoyment. By following these precautions and using common sense, you will have many safe and pleasurable hours of healthful exercise with your equipment.

- After assembly, you should check all functions to ensure correct operation. If you experience problems, first recheck the assembly instructions to locate any possible errors made during assembly. If you are unable to correct the problem, call the dealer from whom you purchased the machine or call the dealer nearest you.

## **Obtaining Service**

- Please use this Owner's Manual to make sure that all parts have been included in your shipment.
- **Retain this Owner's Manual for future reference.**

# **PREPARATION**

Thank you for purchasing this equipment. This machine is part of our line of quality strength training machines, which lets you target specific muscle groups to achieve better muscle tone and overall body conditioning. To maximize your use of the equipment please study this Owner's Manual thoroughly.

## **INSTALLATION Requirements**

Follow these installation requirements when assembling:

Set up the machine on a solid, flat surface. A smooth, flat surface under the machine helps keep it level. A level machine has fewer malfunctions.

Provide ample space around the machine. Open space around the machine allows for easier access.

Insert all bolts in the same direction. For aesthetic purposes, insert all bolts in the same direction unless specified (in text or illustrations) to do otherwise.

Leave room for adjustments. Tighten fasteners such as bolts, nuts, and screws so the unit is stable, but leave room for adjustments. Do not fully tighten fasteners until instructed in the assembly steps to do so.

## **ASSEMBLY Tips**

Read all "Notes" on each page before beginning each step.

While you may be able to assemble the machine using the illustrations only, important safety notes and other tips are included in the text.

Some pieces may have extra holes that you will not use. Use only those holes indicated in the instructions and illustrations.

**NOTE:** With so many assembled parts, proper alignment and adjustment is critical. While tightening the nuts and bolts, be sure to leave room for adjustments.

**NOTE:** The bottles that are marked "Poison" is your touch up paint. Keep away from children.

**CAUTION:** Obtain assistance! If you feel like you can't assemble the machine by yourself then do not attempt to do so as this could result in injury. Review the installation requirements before proceeding with the following steps.

# Exploded Drawing

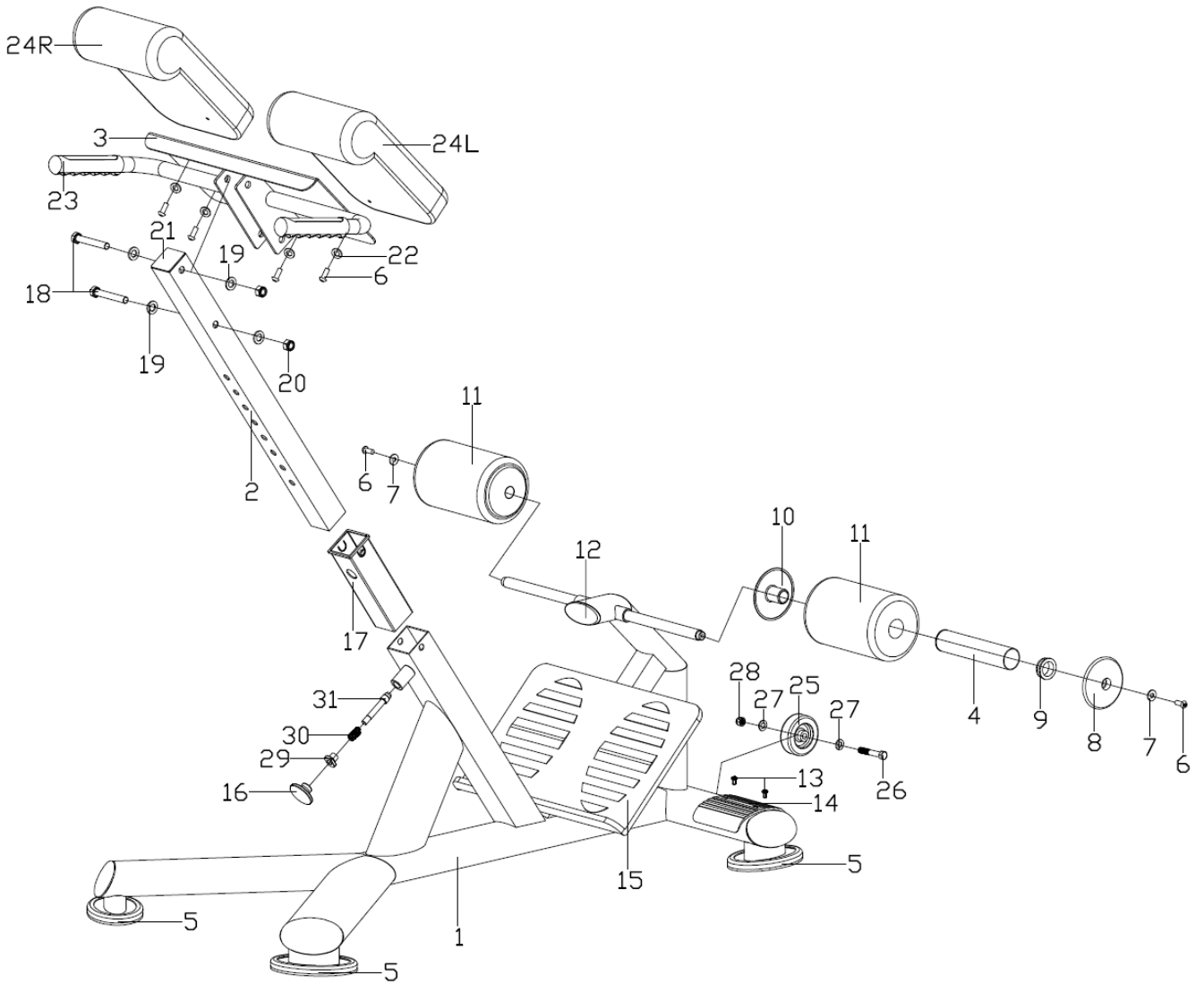

## Parts list

NO.	DESCRIPTION	QTY	NO.	DESCRIPTION	QTY
1	Main Frame	1	17	Plastic Bushing	1
2	Adjustable Tube	1	18	Hex Bolt M12x80	2
3	AB & Back Rest Frame	1	19	Flat Washer D12xD24x2.5	4
4	Roll Foam Tube	1	20	Nylon Nut M12	2
5	Rubber Foot Pad	4	21	Square End Cap	1
6	Allen Bolt M8x20	6	22	Flat Washer D8xΦ16x1.5	4
7	Rear Bottom Tube	2	23	Grip Sleeve	2
8	Roll Foam End Cap	2	24L/R	AB & Back Rest Pad	1/1
9	Bushing	4	25	Moving Wheel	2
10	Roll Foam End Plug	2	26	Hex Bolt M10x50	2
11	Roll Foam	2	27	Flat Washer D10xΦ20x2	4
12	Oval Curved End Cap	1	28	Nylon Nut M10	2
13	Phillips Flat Cap Screw M4 x12	4	29	Pull-Pin Nut	1
14	Step Mat	2	30	Pull-Pin Tension Spring	1
15	Step Pad	1	31	Pull-Pin Rod	1
16	Pull-Pin Knob	1			

### NOTE:

*Most of the listed hardware has been packaged separately, but some of them have been preinstalled in the identified assembly parts. In these instances, simply remove and reinstall the hardware as assembly is required.*

*Please refer the individual steps for the installation and pay attention to the preinstalled hardware.*

# ASSEMBLY INSTRUCTION

**NOTE:** It is well suggested that two or more people to assemble this machine to avoid any possible injury.

Remove all the security tape and wrapping before the installation.

## Step 1

**A.** Lock the AB & Back Rest Frame (3) to the Adjustable Tube (2) with the Hex Bolts (18), Flat Washers (19) and Nylon Nuts (20) as shown.

**B.** Pull the Pull-Pin Knob (16) to insert the Adjustable Tube (2) into the Main Frame (1) section, secured with the Pull-Pin Knob (16) at a proper position, Always **MAKE SURE** the Pull-Pin Rod has been popped into the Designed Hole on the Adjustable Tube (2) before Exercise.

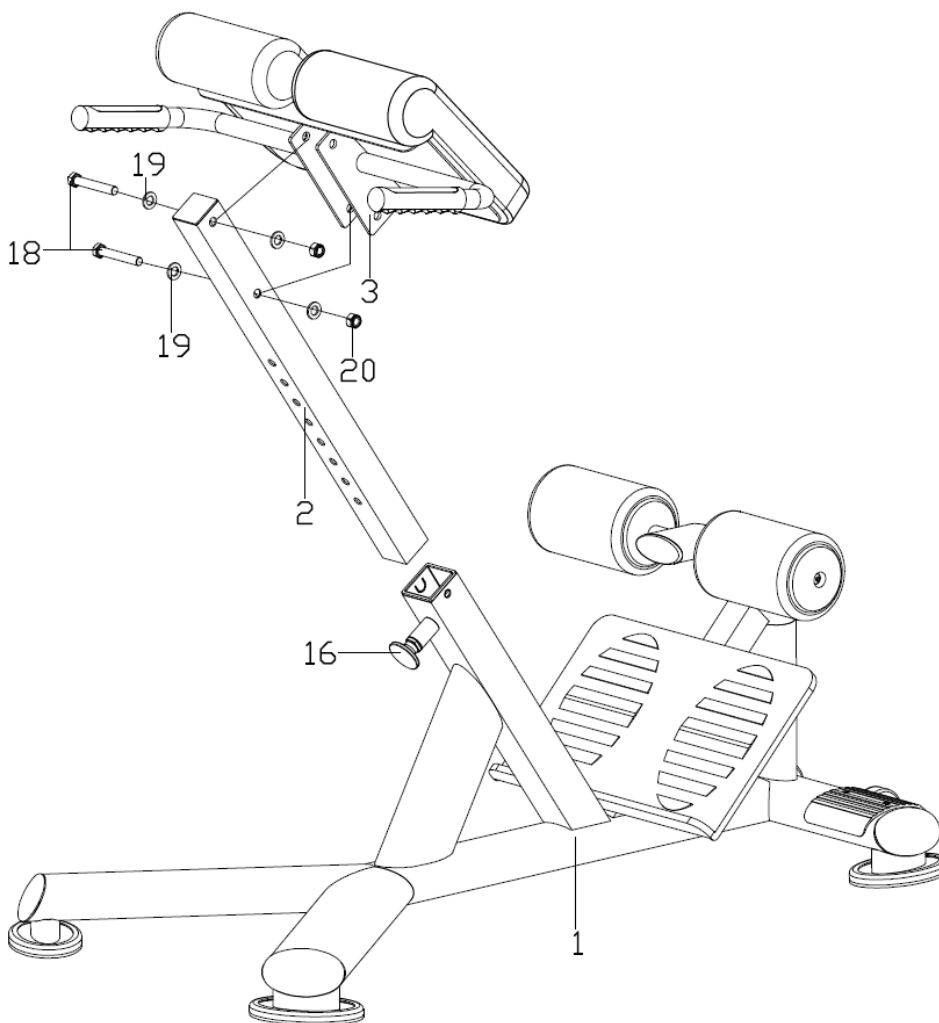

# WARM-UP and COOL-DOWN

Using your machine will provide you with several benefits. It will improve your physical fitness, tone your muscles and in conjunction with a calorie controlled diet, help you lose weight.

## WARM-UP PHASE

The purpose of warming up is to prepare your body for exercise and to minimize injuries. Warm up for two to five minutes before strength-training or aerobic exercising. Perform activities that raise your heart rate and warm the working muscles. Activities may include brisk walking, jogging, jumping jacks, jump rope, and running in place.

## STRETCHING

Stretching while your muscles are warm after a proper warm-up and again after your strength or aerobic training session is very important. Muscles stretch more easily at these times because of their elevated temperature, which greatly reduces the risk of injury. Stretches should be held for 15 to 30 seconds.

**DO NOT BOUNCE.**

**Remember always to check with your physician before starting any exercise program.**

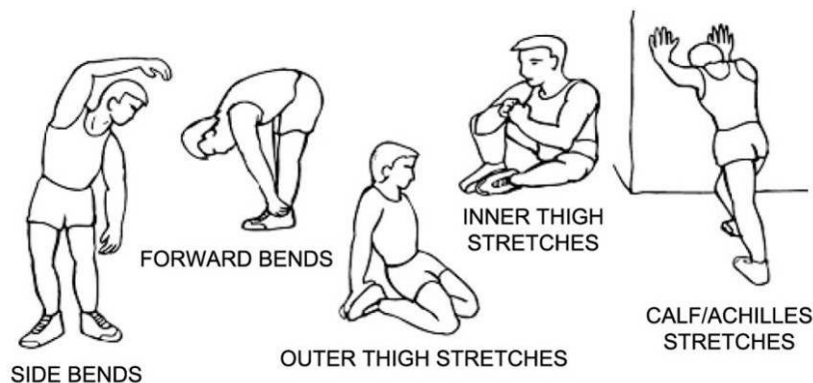

## EXERCISE PHASE

This is the stage where you put the effort in. After regular use, the muscles in your legs will become more flexible. Work at your own pace and be sure to maintain a steady tempo throughout. The rate of work should be sufficient to raise your heartbeat into the target zone shown on the graph below.

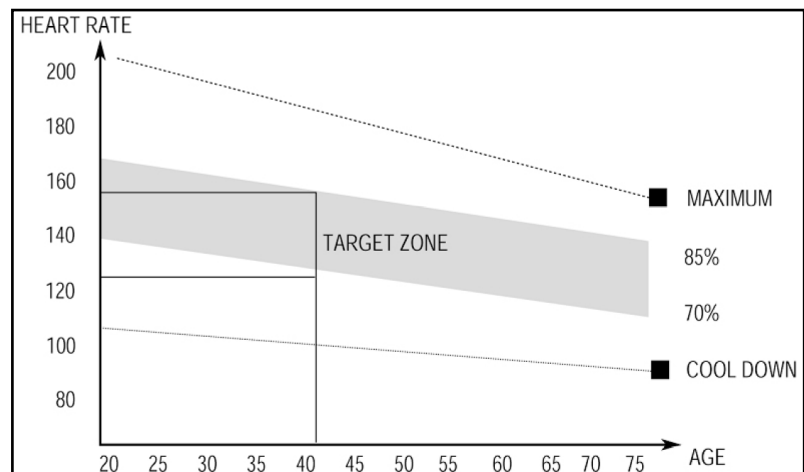

## COOL-DOWN PHASE

The purpose of cooling down is to return the body to its normal or near normal, resting state at the end of each exercise session. A proper cool-down slowly lowers your heart rate and allows blood to return to the heart.