



MANUFACTURED BY:  
**Backyard Discovery**  
3305 Airport Drive, Pittsburg, KS 66762  
800-856-4445

Basepoint Business Centre: Rivermead Drive, Westlea, Swindon SN5 7EX Phone: 0800-118-2476  
J.P. Coenstraat 7, The Bridge, The Hague, 2595 WP, Netherlands Phone: 0800-567-8990

# HILLCREST

## Swing Set

### Model # 1808058B



#### WARNING

**Adult Assembly Required.**

Not suitable for children under 36 months due to small parts.

**FOR DOMESTIC USE ONLY. INTENDED FOR OUTDOOR USE.**



**Please visit [www.backyarddiscovery.com](http://www.backyarddiscovery.com)**

For the most up to date assembly manual, to register your set, or to order replacement parts

*Para obtener instrucciones en español, visite [www.backyarddiscovery.com](http://www.backyarddiscovery.com)*



**EASY STEP-BY-STEP**  
**3D INTERACTIVE INSTRUCTIONS**

DOWNLOAD THE FREE APP



**INSTALLATION**  
**SERVICES**  
**AVAILABLE!**

*See inside for details*

Made in China  
INS-1808058B-A-HILLCREST-ENG 01-04-22



### Please read entire booklet completely before beginning the assembly process

Please retain these instructions and your receipt for future reference. Keep them in a safe place where you can refer to them as needed. In order to provide you with the most efficient service, it is required that you provide us with the part numbers when ordering parts.

#### For Your Records:

Please take time and fill out the information below. This information will be needed for warranty issues.

Where Purchased: \_\_\_\_\_  
 Date of Purchase: \_\_\_\_\_  
 Installation Date: \_\_\_\_\_  
 Installed by: \_\_\_\_\_  
 Tracking Number: \_\_\_\_\_

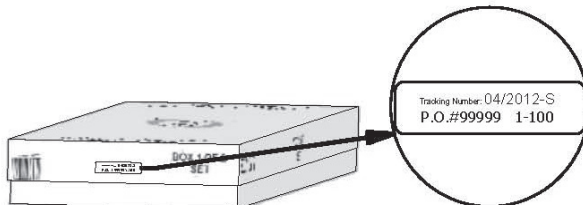
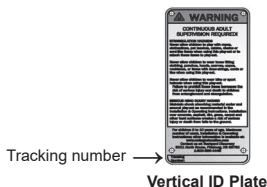

#### Tracking Number Reference Label

Tracking ID number on the carton and on the bottom of the vertical ID plate are included for tracking purposes associated with warranty claims.

This Limited Warranty by Backyard Discovery applies to products manufactured under the Backyard Discovery brand or its other brands including but not limited to Backyard Botanical, Adventure Playsets, and Leisure Time Products.

Backyard Discovery warrants that this product is free from defect in materials and workmanship for a period of one (1) year from the original date of purchase. This one (1) year warranty covers all parts including wood, hardware, and accessories. All wood carries a five (5) year pro-rated warranty against rot and decay. Refer to the schedule below for charges associated with replacement of parts under this Limited Warranty. In addition, Backyard Discovery will replace any parts within the first 30 days from date of purchase found to be missing from or damaged in the original packaging.

This warranty applies to the original owner and registrant and is non-transferable. Regular maintenance is required to assure maximum life and performance of this product. Failure by the owner to maintain the product according to the maintenance requirements may void this warranty. Maintenance guidelines are provided in the Owner's Manual.

This Limited Warranty does not cover:

- Labor for any inspection
- Labor for replacement of any defective item(s)
- Incidental or consequential damages
- Cosmetic defects which do not affect performance or integrity of a part or the entire product
- Vandalism, improper use, failure due to loading or use beyond the capacities stated in the applicable Assembly Manual.
- Acts of nature including but not limited to wind, storms, hail, floods, excessive water exposure
- Improper installation including but not limited to installation on uneven, unlevel, or soft ground
- Minor twisting, warping, checking, or any other natural occurring properties of wood that do not affect performance or integrity

Backyard Discovery products have been designed for safety and quality. Any modifications made to the original product could damage the structural integrity of the unit leading to failure and possible injury. Modification voids any and all warranties and Backyard Discovery assumes no liability for any modified products or consequences resulting from failure of a modified product.

This product is warranted for RESIDENTIAL USE ONLY. Under no circumstance should a Backyard Discovery product be used in public settings. Such use may lead to product failure and potential injury. Any and all public use will void this warranty. Backyard Discovery disclaims all other representations and warranties of any kind, express or implied.

#### Pro Rated Part Replacement Schedule

<u>Product Age</u>	<u>Customer Pays</u>
<b>All Parts</b>	
0-30 days from date of purchase	\$0 and free shipping
31 days to 1 year	\$0 + S&H
<b>Wood Rot and Decay Only</b>	
1 year	\$0 and free shipping
2 year	20% + S&H
3 year	40% + S&H
4 year	60% + S&H
5 year	80% + S&H
Over 5 years	100% + S&H



### NOTE:

#### Your Children's Safety Is Our #1 Concern!

Observe the following statements and warnings to reduce the likelihood of serious or fatal injury. Please review these safety rules regularly with your children.



### WARNING: BURN HAZARD

- Pay special attention to plastic and metal surfaces as they may be hot enough to cause burns.
- Always check the temperature of the product before letting your children play on it.
- Remember that the product may cause burns if left in direct sunlight.
- Always be aware of the sun and weather conditions, and do not assume that the equipment is safe because the air temperature is not very high.

- Children **MUST NOT** use this playcenter until unit has been completely assembled and inspected by an adult to ensure set has been properly installed and anchored.
- Equipment is recommended for use by children 3 to 10 years of age.
- This Playcenter is designed for a specific number of occupants whose combined weight should not exceed the designated weight on the elevated floor or the swing area. The total unit capacity is outlined in the Basic Setup Dimensions section of instruction manual. The maximum fall height and recommended play area is also available in the Basic Setup Dimensions section of the manual.
- On-site, continuous adult supervision is **REQUIRED. MOST SERIOUS INJURIES AND DEATHS ON PLAYGROUND EQUIPMENT HAVE OCCURRED WHILE CHILDREN WERE UNSUPERVISED!**
- **DO NOT** allow children to walk close to, in front of, behind, or between moving swings or other moving playground equipment.
- **DO NOT** let children stand on swings.
- Children should **NOT** twist the chains and ropes and should not loop them over the top support bar, this could reduce the strength of the chain or rope.
- **DO NOT** let children push empty seats. The seat could hit them and cause serious injury.
- Instruct and teach children to sit in the center of the swings with their full weight on the seats.
- **DO NOT** allow children to use the equipment in a manner other than intended.
- Instruct children **NOT** to get off equipment while it is in motion.
- Instruct children to **ALWAYS** go down slides feetfirst. Never slideheadfirst.
- Instruct children to **LOOK** before they slide to make sure no one is at the bottom.
- **DO NOT** allow children to run up a slide, as this increases their chances of falling.
- **DRESS CHILDREN APPROPRIATELY.** (Examples would include wearing well-fitting shoes and the avoidance of ponchos, scarfs, and other loose-fitting clothing that is potentially hazardous while using equipment).
- **DO NOT** allow children to climb when the equipment is wet.
- Children should **NEVER** jump from a fort deck. They should always use the ladder, ramp or slide.
- Children should **NEVER** be allowed to crawl or walk across the top of monkey bars.
- **DO NOT** allow children to crawl on top of a fort roof.
- Verify that any suspended climbing ropes, chain, or cable are secured at both ends and that they cannot be looped back on themselves as to create an entanglement hazard.
- **DO NOT** let children attach items to the playground equipment that are not specifically designed for use with the equipment. Items such as, but not limited to, jump ropes, clothesline, pet leashes, cables and chain can cause a strangulation hazard.
- Children should **NEVER** wrap their legs around swing chain.
- **DO NOT** allow children to slide down the swing chain.
- Instruct children to remove their bike or other sports helmet before playing on playground equipment.
- **NEVER** add extra length to chain or rope. The chains or ropes provided are the maximum length designed for the swinging element(s).

### Modifications

- Modifications made by the consumer to the original activity toy shall be carried out according to the instructions of the manufacturer. In particular, instructions shall be provided with kit/accessory about the installation of rope/nets concerning the minimum diameter, the need for fixation at both ends, overall length, and positioning in relation to other structures.



### Positioning Your Playcenter

- The playcenter is designed to be installed on a level surface by an adult with an adult helper. Place in a flat area of your yard to minimize ground preparation.
- Choose a level location for the equipment. This can reduce the likelihood of the play set tipping over and loose-fill surfacing material washing away during heavy rains.
- Place the equipment not less than 6'-7" (2.0 m) from any structure or obstruction such as a fence, garage, house, overhanging branches, laundry lines, or electrical wires.
- Provide enough room so that the children can use the equipment safely. For example, for structures with multiple play activities, a slide should not exit in front of a swing.
- It is a good idea to place your playcenter in an area that is convenient for adults to watch children at play.
- Create a site free of obstacles that could cause injuries – such as low overhanging tree branches, overhead wires, tree stumps and/or roots, large rocks, bricks and concrete. Additional suggestions in the Suggested Playground Surfacing Section.
- Do not build your playset on top of surfacing material.
- Locate bare metal platforms and slides out of direct sunlight to reduce the likelihood of serious burns. A slide that faces north will receive the least direct sunlight.
- Separate active and quiet activities from each other. For example, locate sandboxes away from swings or use a guardrail or barrier to separate the sandbox from the movement of the swings.

### Suggested Playground Surfacing

- Do not install home playground equipment over concrete, asphalt, packed earth, grass, carpet, or any other hard surface. A fall onto a hard surface can result in serious injury to the equipment user.
- Do not install loose fill surfacing over hard surfaces such as concrete or asphalt.
- Shredded bark mulch, wood chips, fine sand and fine gravel, are added as shock absorbing materials after assembly. If used properly these materials can absorb some of the impact of a child's fall.
- All surface material should extend a minimum of 6'-7" (2.0 m) feet in all directions around the play area.
- Do not apply playground surfacing until after the unit is completely constructed. Playset should not be built on top of surfacing.
- Use containment, such as digging out around the perimeter and/or lining the perimeter with landscape edging.
- Installations of rubber tiles or poured-in-place surfaces (other than loose-fill materials) generally require a professional and are not "do-it-yourself" projects.
- Shall use Playground Surfacing Materials (other than loose-fill material) which comply with the safety standard ASTM F1292 Standard Specification of Impact Attenuation of Surfacing Materials within the Use Zone of Playground Equipment.
- Anchors shall be placed as instructed to reduce tipping hazards.

The following chart explains the fall height in feet from which a life threatening head injury would not be expected

### Critical Heights in feet (m) of Tested Materials

Material	Uncompressed Depth			Compressed Depth to 9" (228mm)
	6" (152mm)	9" (228mm)	12" (304mm)	
Wood Chips	7' (2.13m)	10-12' (3.0-3.6m)	11' (3.35m)	10' (3.05m)
Double-Shredded Bark Mulch	6' (1.83m)	10-12' (3.0-3.6m)	11' (3.35m)	7' (2.13m)
Engineered Wood Fibers	6' (1.83m)	7' (2.13m)	>12' (3.66m)	6' (1.83m)
Fine Sand	5' (1.52m)	5' (1.52m)	9' (2.74m)	5' (1.52m)
Coarse Sand	5' (1.52m)	5' (1.52m)	6' (1.83m)	4' (1.22m)
Fine Gravel	5' (1.52m)	7' (2.13m)	10' (3.05m)	6' (1.83m)
Medium Gravel	5' (1.52m)	5' (1.52m)	6' (1.83m)	5' (1.52m)
Shredded Tires*	10-12' (3.0-3.6m)	N/A	N/A	N/A

\*This data is from tests conducted by independent testing laboratories on a 6-inch depth of uncompressed shredded tire samples produced by four manufacturers. The tests reported critical heights, which varied from 10 feet to greater than 12 feet. It is recommended that persons seeking to install shredded tires as a protective surface request test data from the supplier showing the critical height of the material when it was tested in accordance with ASTM F1292.





### APPENDIX A

**The following information is from the United States Consumer Product Safety Commission's Information Sheet for playground surfacing material; also see the following website for additional information: [www.cpsc.gov](http://www.cpsc.gov)**

#### X3. SECTION 4 OF THE CONSUMER PRODUCT SAFETY COMMISSION'S OUTDOOR HOME PLAYGROUND SAFETY HANDBOOK<sup>9</sup>

X3.1 Select Protective Surfacing—One of the most important things you can do to reduce the likelihood of serious head injuries is to install shock-absorbing protective surfacing under and around your play equipment. The protective surfacing should be applied to a depth that is suitable for the equipment height in accordance with ASTM Specification F 1292. There are different types of surfacing to choose from; whichever product you select, follow these guidelines:

##### X3.1.1 Loose-Fill Materials:

X3.1.1.1 Maintain a minimum depth of 9 inches of loose-fill materials such as wood mulch/chips, engineered wood fiber (EWF), or shredded/recycled rubber mulch for equipment up to 8 feet high; and 9 inches of sand or pea gravel for equipment up to 5 feet high. NOTE: An initial fill level of 12 inches will compress to about a 9-inch depth of surfacing overtime. The surfacing will also compact, displace, and settle, and should be periodically refilled to maintain at least a 9-inch depth.

X3.1.2 Use a minimum of 6 inches of protective surfacing for play equipment less than 4 feet in height. If maintained properly, this should be adequate. (At depths less than 6 inches, the protective material is too easily displaced or compacted.)

NOTE: Do not install home playground equipment over concrete, asphalt, or any other hard surface. A fall onto a hard surface can result in serious injury to the equipment user. Grass and dirt are not considered protective surfacing because wear and environmental factors can reduce their shock absorbing effectiveness. Carpeting and thin mats are generally not adequate protective surfacing. Ground level equipment such as a sandbox, activity wall, playhouse or other equipment that has no elevated play surface – does not need any protective surfacing.

X3.1.3 Use containment, such as digging out around the perimeter and/or lining the perimeter with landscape edging. Don't forget to account for water drainage.

X3.1.3.1 Check and maintain the depth of the loose-fill surfacing material. To maintain the right amount of loose-fill materials, mark the correct level on play equipment support posts. That way you can easily see when to replenish and/or redistribute the surfacing.

X3.1.3.2 Do not install loose-fill surfacing over hard surfaces such as concrete or asphalt.

X3.1.4 Poured-In-Place Surfaces or Pre-Manufactured Rubber Tiles — You may be interested in using surfacing other than loose-fill materials – like rubber tiles or poured-in-place surfaces.

X3.1.4.1 Installations of these surfaces generally require a professional and are not “do-it-yourself” projects.

X3.1.4.2 Review surface specification before purchasing this type of surfacing. Ask the installer/manufacture for a report showing that the product has been tested to the following safety standard: ASTM F 1292 Standard Specification for Impact Attenuation of Surfacing Materials within the Use Zone of Playground Equipment. This report should show the specific height for which the surface is intended to protect against serious head injury. This height should be equal to or greater than the fall height – vertical distance between a designated play surface (elevated surface for standing, sitting, or climbing) and the protective surfacing below – of your play equipment

X3.1.4.3 Check the protective surfacing frequently for wear.

X3.1.5 Placement — Proper placement and maintenance of protective surfacing is essential. Be sure to:

X3.1.5.1 Extend surfacing at least 6 feet from the equipment in all directions.

X3.1.5.2 For to-fro swings, extend protective surfacing in front of and behind the swing to a distance equal to twice the height of the top bar from which the swing is suspended.

<sup>9</sup>This information has been extracted from the CPSC publications “Playground Surfacing — Technical Information Guide” and “Handbook for Public Playground Safety.” Copies of these reports can be obtained by sending a postcard to the: Office of Public Affairs, U.S. Consumer Product Safety Commission, Washington, D.C., 20207 or call the toll-free hotline: 1-800-638-2772.

The American Society for Testing and Materials takes no position respecting the validity of any parent right asserted in connection with any item mentioned in this standard. Users of this standard are expressly advised that determination of the validity of any such parent rights, and the risk of infringement of such rights, are entirely their own responsibility.

The standard is subject to revision at any time by the responsible technical committee and must be reviewed every five years and if not revised, either approved or withdrawn. Your comments are invited either for revision of this standard or for additional standards and should be addressed to ASTM Headquarters. Your comments will receive careful consideration at a meeting of the responsible technical committee, which you may attend. If you feel that your comments have not received a fair hearing you should make your views known to the ASTM Committee on Standards. 100 Barr Harbor Drive, West Conshohocken, PA 19428.



**IT IS IMPORTANT TO CHECK AND TIGHTEN ALL HARDWARE AT THE BEGINNING AND DURING THE SEASON AS THEY MAY LOOSEN DUE TO WOOD EXPANSION AND CONTRACTION.**

### At the beginning of each play season

- Tighten all hardware.
- Lubricate all metallic moving parts per manufacturer's instructions.
- Check all protective coverings on bolts, pipes, edges, and corners. Replace if they are loose, cracked, or missing.
- Check all moving parts including swing seats, ropes, cables, and chains for wear, rust, or other deterioration. Replace as needed.
- Check metal parts for rust. If found, sand and repaint using a non lead-based paint meeting the requirements of 16 CFR 1303.
- Check all wood members for deterioration and splinters. Sand down splinters and replace deteriorating wood members.
- Reinstall any plastic parts, such as swing seats or any other items that were removed for the cold season.
- Rake and check depth of loose fill protective surfacing materials to prevent compaction and to maintain appropriate depth. Replace as necessary.

### Twice a month during play season

- Tighten all hardware.
- Check all protective coverings on bolts, pipes, edges, & corners. Replace if they are loose, cracked, or missing.
- Rake and check depth of loose fill protective surfacing materials to prevent compaction and to maintain appropriate depth. Replace as necessary.

### Once a month during play season.

- Lubricate all metallic moving parts per manufacturer's instructions.
- Check all moving parts including swing seats, ropes, cables, and chains for wear, rust, or other deterioration. Replace as needed.

### At the end of each season or when the temperature drops below 32° F

- Remove plastic swing seats and other items as specified by the manufacturer and take indoors or do not use.
- Rake and check depth of loose fill protective surfacing materials to prevent compaction and to maintain appropriate depth. Replace as necessary.

### Additional Maintenance

- Check the swing beam and hardware every two weeks due to wood expansion and contraction. It is particularly important that this procedure be followed at the beginning of each season.
- Inspect wood parts monthly. The grain of the wood sometimes will lift in the dry season causing splinters to appear. Light sand may be necessary to maintain a safe playing environment. Treat your playset with stain regularly, to help prevent severe checking/splitting and other weather damage.
- A waterborne transparent stain has been applied to your playset. This is done for color only. Once or twice a year, depending on your climate conditions, you must apply some type of protection (sealant) to the wood of your unit. Prior to the application of sealant, lightly sand any "rough" spots on your playset. Please note this is a requirement of your warranty.
- Assembling and maintaining the playset on a level location is very important. As your children play, your playset will slowly dig its way into the soil, and it is very important that it settles evenly. Make sure the playset is level and true one each year or at the beginning of each play season.

### Disposal Instructions

When the Playcenter use is no longer desired, it should be disassembled and disposed of in such a way that no unreasonable hazards will exist at the time the unit is discarded.

### Third Party Assembly

Customer may, in their sole discretion, elect to use a third party person or service to assemble this product. Backyard Discovery assumes no responsibility or liability for any charge incurred by the Customer for any assembly services'. Please see our warranty for more information about damaged and missing part replacement coverage. Backyard Discovery will not reimburse Customer for the price of parts purchased.

- Modifications made by the consumer to the original activity to be carried out according to the instructions of the manufacturer. The instructions shall be provided with kit/accessory about the installation of rope/nets concerning the minimum diameter, the need for fixed ends, overall length, and positioning in relation to other structures.

**OWNERS SHALL BE RESPONSIBLE FOR MAINTAINING THE LEGIBILITY OF THE WARNING LABELS**



***Your Backyard Discovery structure is designed and constructed of quality materials. As with all outdoor products it will weather and wear. To maximize the enjoyment, safety and life of your structure it is important that you properly maintain it.***

---

### About Our Wood

Backyard Discovery uses 100% Cedar (C. Lanceolata) wood. Although we take great care in selecting the best quality lumber available, wood is still a product of nature and susceptible to weathering which can change the appearance of your set.

#### **What causes weathering? Does it affect the strength of my product?**

One of the main reasons for weathering is the effects of water (moisture); the moisture content of the wood at the surface is different than the interior of the wood. As the climate changes, moisture moves in or out of the wood, causing tension which can result in checking and or warping. You can expect the following due to weathering. These changes will not affect the strength of the product:

**1. Checking** is surface cracks in the wood along the grain. A post (4" x 4") will experience more checking than a board (1" x 4") because the surface and interior moisture content will vary more widely than in thinner wood.

**2. Warping** results from any distortion (twisting, cupping) from the original plane of the board and often happens from rapid wetting and drying of the wood.

**3. Fading** happens as a natural change in the wood color as it is exposed to sun-light and will turn grey over time.

#### **How can I reduce the amount of weathering to wood product?**

**1.** Your wood product is coated with a water-based stain. Sunlight will break down the coating, so we recommend applying a water repellent or stain on a yearly basis (see your local stain and paint supplier for a recommended product). You must apply some type of protection (sealant) to the wood of your product. **Please note this is a requirement of your warranty.** Most weathering is just the normal result of nature and will not affect safety. However if you are concerned that a part has experienced a severe weathering problem please call our customer service department for further assistance.

**2.** Inspect wood parts monthly. The grain of the wood sometimes will lift in the dry season causing splinters to appear. Light sanding may be necessary to maintain a safe environment. Treating your Product with protection (sealant) after sanding will help prevent severe checking/splitting and other weather damage.



### Protrusion Hazard

### Incorrect

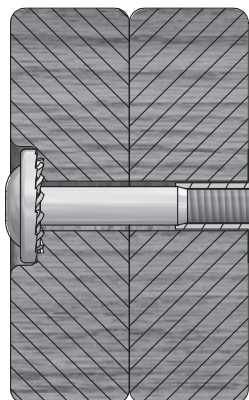

If you see exposed threads and your bolt protrudes beyond the T-Nut you may have over tightened the bolt or used incorrect hardware. If you've overtightened, remove the bolt and add washers to eliminate the protrusion.

### Correct

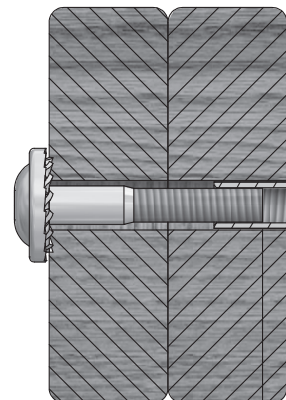

1/8"

## Proper Hardware Assembly

### Bolt and T-Nut Assembly

Tap T-nut into the provided hole. Insert your bolt through the lock washer and insert into the provided hole opposite from the T-Nut. Turn clockwise to thread into T-nut. Do not completely tighten until instructed.

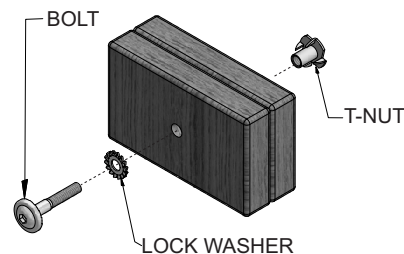

### Bolt and Barrel Nut Assembly

Insert barrel nut through the lock washer and press the pair through the provided hole. Insert your bolt through the second lock washer and insert the pair into the provided hole opposite from the barrel nut. Turn clockwise to thread into the barrel nut. Do not completely tighten until instructed.

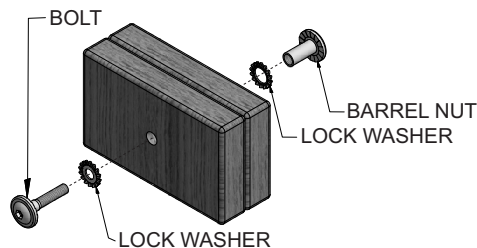

### Lag Assembly

Normally there will be a pre-drilled pilot hole on assemblies that require a Lag Screw. If there is no pilot hole, line up the two boards as they are to be attached and use the factory drilled hole as a guide to drill another pilot hole into the adjoining board. This will keep the wood from splitting. Only a lock washer is required for steps with Lag Screws.

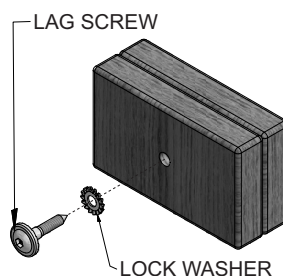





### ASSEMBLY TIP:

Keep an eye out for these boxes which will contain helpful pictures and information making the assembly process as quick and painless as possible.

## Sorting Wood

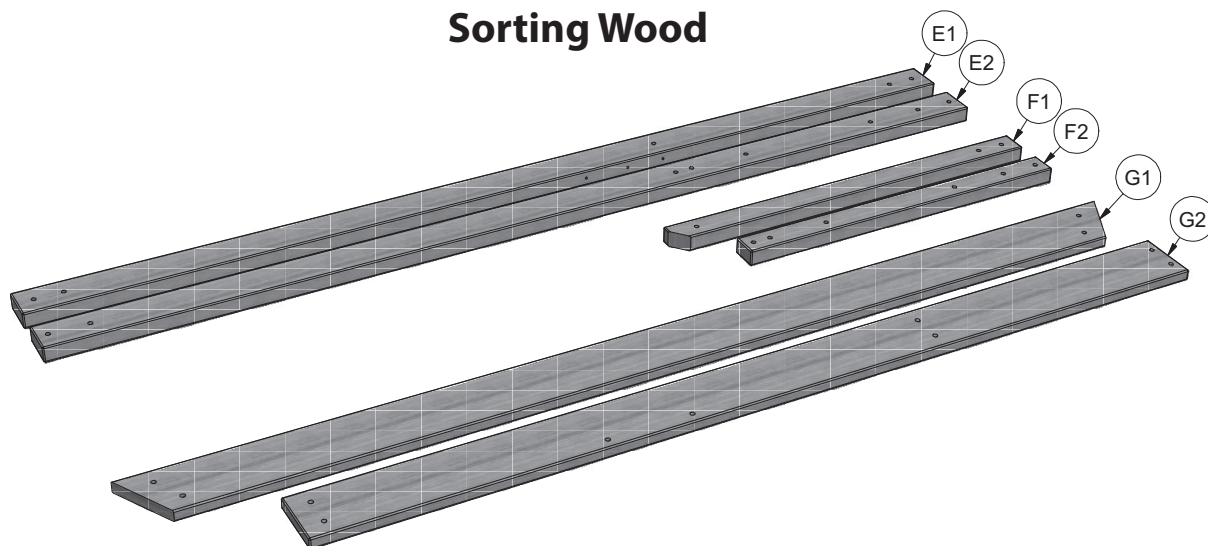

When removing the wood from the boxes we recommend arranging them by part number before you begin assembly. This will allow for faster assembly and easily identify any parts that may be missing or damaged.

## Sorting Hardware

**NUT BARREL**  
H100545



**SCREW**  
H100695

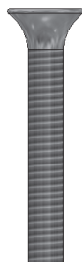

**T-NUT**  
H100699



**WASHER FLAT**  
H100706

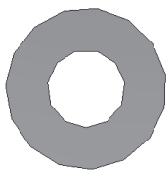

**BOLT HEX**  
H100716

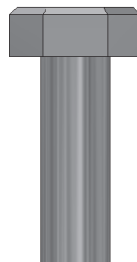

**BOLT**  
H100718



**SCREW PWH**  
H100742

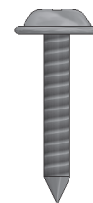

To help with assembly we recommend sorting your hardware bags with the seven digit alpha-numeric number printed on the bags or by hardware type (i.e. bolts, nuts, etc.). Organizing your hardware will make assembly easier.

## Hardware Identification

Hardware bags are printed with a seven digit alpha-numeric part number. During assembly you only need to reference the last three digits of the part number as noted in each step. This will make finding the correct hardware easier.

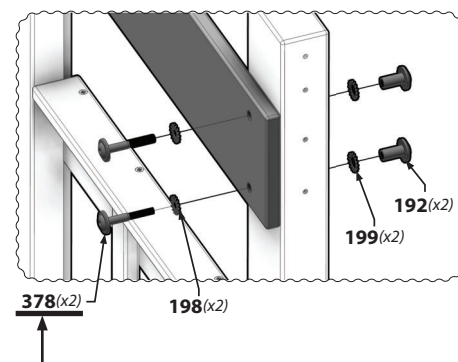
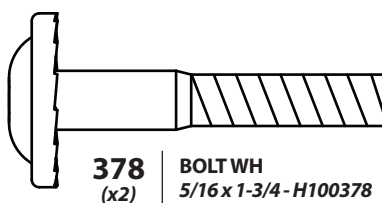



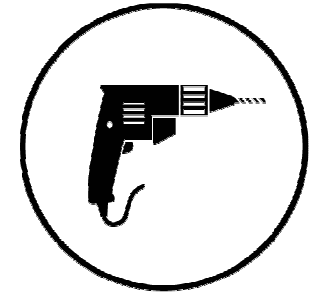
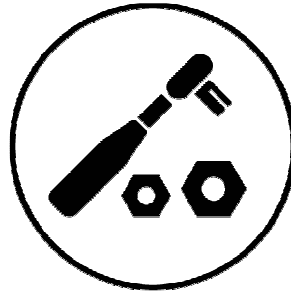
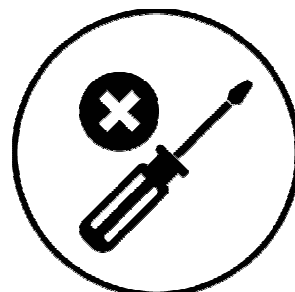
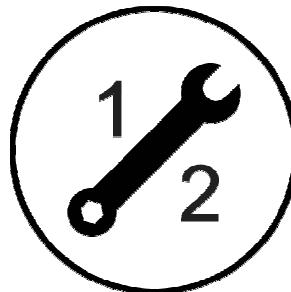
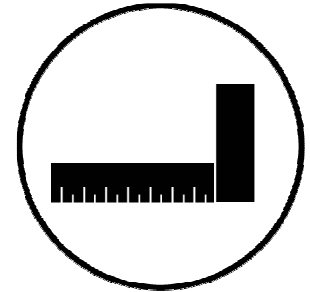
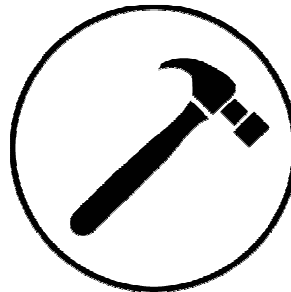
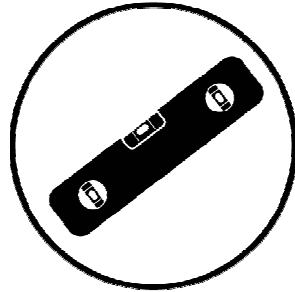
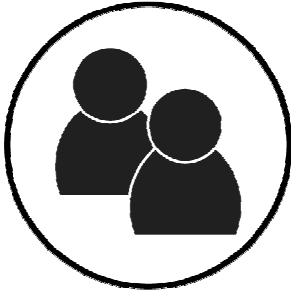

Icons and their uses you will see throughout this manual



You will need to make sure that your assembly is square before tightening your bolts.



For proper assembly you will need to ensure that your structure is level before proceeding to the next step.



Some steps in the assembly process will require an extra set of hands. Make sure you have a helper available.



This icon shows the size of an open ended wrench. Using the wrench as the fraction bar.



When you see this icon you will need a socket wrench. The icons below show the size of attachments needed for assembly 1/2.

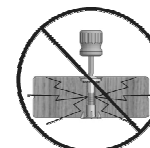

This icon warns you to not over tighten your bolts. This is to prevent structural damage and also splintering your wood.



This icon will show you what drill attachments are needed. For this example you will need a Phillips head attachment and 3/8 socket.



# Owner's Manual - Parts Identification

## Wood Components (Not to Scale)

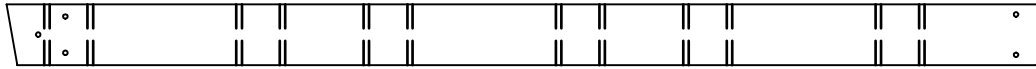

**A50 | SWING BEAM - W4L15998**  
(x1) | 3 3/8"x5 1/4"x89 1/2" (86x134x2274)

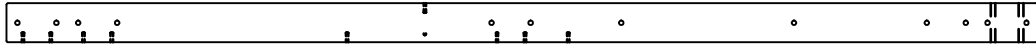

**E01 | RIGHT FRONT TOWER LEG - W4L15999**  
(x1) | 1 3/8"x3 3/8"x89 1/2" (36x86x2274)

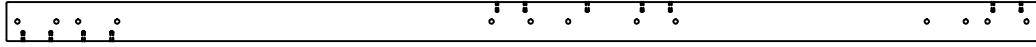

**E02 | CENTER FRONT TOWER LEG - W4L16000**  
(x1) | 1 3/8"x3 3/8"x89 1/2" (36x86x2274)

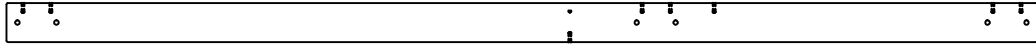

**E03 | LEFT FRONT TOWER LEG - W4L16001**  
(x1) | 1 3/8"x3 3/8"x89 1/2" (36x86x2274)

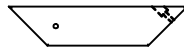

**E04 | DECK BRACE - W4L16002**  
(x8) | 1 3/8"x3 3/8"x15 1/2" (36x86x394)

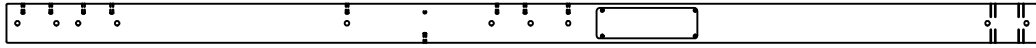

**E05 | RIGHT REAR TOWER LEG - W2A03282**  
(x1) | 1 3/8"x3 3/8"x89 1/2" (36x86x2274)

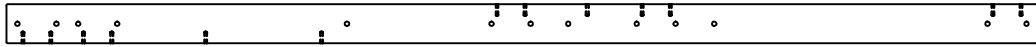

**E06 | CENTER REAR TOWER LEG - W4L16005**  
(x1) | 1 3/8"x3 3/8"x89 1/2" (36x86x2274)

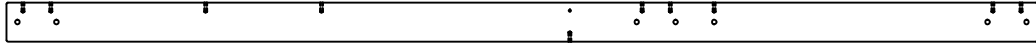

**E07 | LEFT REAR TOWER LEG - W4L16006**  
(x1) | 1 3/8"x3 3/8"x89 1/2" (36x86x2274)

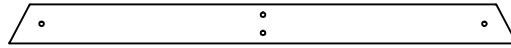

**E50 | END SUPPORT - W4L16003**  
(x1) | 1 3/8"x3 3/8"x44 1/8" (36x86x1120)

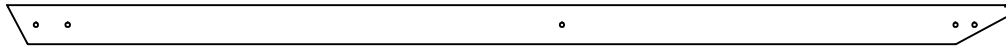

**E51 | ANGLE BRACE - W4L16004**  
(x2) | 1 7/16"x3 3/8"x87 3/16" (36x86x2214)

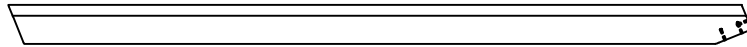

**E72 | LEFT RAIL - W4L16007**  
(x1) | 1 3/8"x3 3/8"x64 1/2" (36x86x1640)

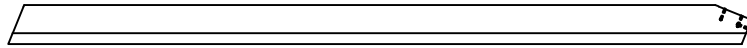

**E73 | RIGHT RAIL - W4L16008**  
(x1) | 1 3/8"x3 3/8"x64 1/2" (36x86x1640)



**E74 | LEFT UPRIGHT - W4L16028**  
(x1) | 1 3/8"x3 3/8"x50 3/4" (36x86x1290)

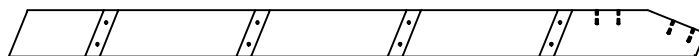

**E75 | RIGHT UPRIGHT - W4L16029**  
(x1) | 1 3/8"x3 3/8"x50 3/4" (36x86x1290)

# Owner's Manual - Parts Identification

## Wood Components (Not to Scale)

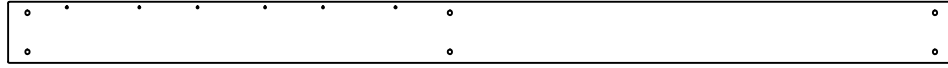

**G01 | BASE BOARD - W4L16009**  
(x2) | 5/8"x5 1/4"x82 1/4" (16x134x2088)

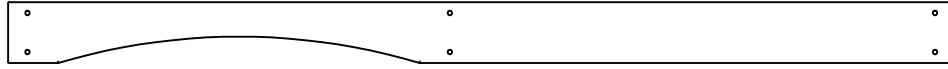

**G02 | WALL RAIL - W4L16015**  
(x1) | 1"x5 1/4"x82 1/4" (24x134x2088)

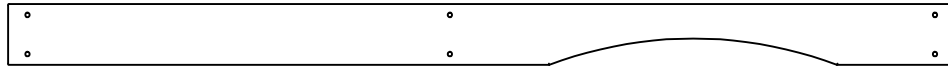

**G03 | WALL RAIL - W4L16016**  
(x1) | 1"x5 1/4"x82 1/4" (24x134x2088)



**G04 | FLOOR RAIL - W4L16017**  
(x2) | 5/8"x5 1/4"x49" (16x134x1244)



**G05 | WALL RAIL/SWING MOUNT - W4L16018**  
(x1) | 1"x5 1/4"x49" (24x134x1244)

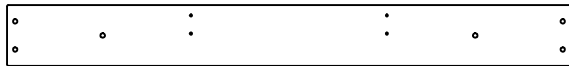

**G06 | FLOOR RAIL - W4L16020**  
(x1) | 1"x5 1/4"x49" (24x134x1244)

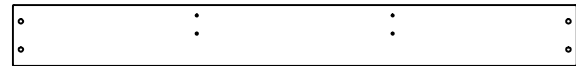

**G07 | FLOOR RAIL - W4L16021**  
(x2) | 1"x5 1/4"x49" (24x134x1244)



**G08 | WALL RAIL - W4L16022**  
(x2) | 1"x5 1/4"x49" (24x134x1244)



**G09 | FLOOR RAIL - W4L16036**  
(x1) | 1"x5 1/4"x49" (24x134x1244)



**G10 | FLOOR RAIL - W4L16010**  
(x1) | 1"x5 1/4"x45 1/2" (24x134x1156)

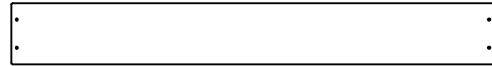

**G11 | PICNIC TABLE TOP - W4L16011**  
(x2) | 5/8"x5 1/4"x42" (16x134x1066)

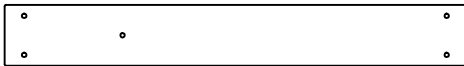

**G12 | FLOOR RAIL - W4L16012**  
(x2) | 1"x5 1/4"x40 1/8" (24x134x1018)

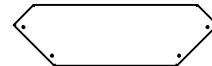

**G13 | SAND BOX SEAT - W4L16013**  
(x2) | 1"x5 1/4"x17 3/4" (24x134x450)

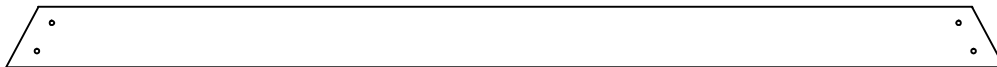

**G14 | GROUND BOARD - W4L16019**  
(x1) | 15/16"x5 1/4"x86 11/16" (24x134x2202)

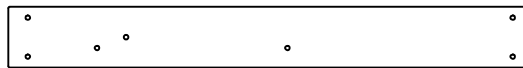

**G15 | FLOOR RAIL - W4L16014**  
(x1) | 1"x5 1/4"x45 1/2" (24x134x1156)



**H01 | FLOOR JOIST - W4L16023**  
(x2) | 1"x3 3/8"x45 1/2" (24x86x1156)

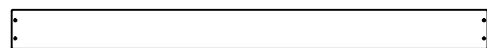

**H02 | PICNIC TABLE SEAT - W4L16025**  
(x2) | 1"x3 3/8"x41 3/8" (24x86x1050)



**H03 | FLOOR JOIST - W4L16026**  
(x2) | 1"x3 3/8"x40 1/8" (24x86x1018)

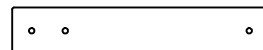

**H04 | SEAT UPRIGHT - W4L16027**  
(x2) | 1"x3 3/8"x19" (24x86x482)

# Owner's Manual - Parts Identification

## Wood Components (Not to Scale)



**H05** | BOTTOM FLOOR BOARD SUPPORT - W4L16024  
(x10) | 1"x3 3/8"x5 1/4" (24x86x134)

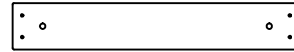

**H06** | LADDER MOUNT - W4L16088  
(x1) | 1"x3 3/8"x21" (24x86x532)

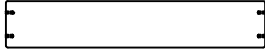

**H07** | LADDER RUNG - W4L16030  
(x4) | 15/16"x3 3/8"x18 7/8" (24x86x480)

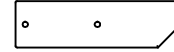

**H08** | TABLE SUPPORT - W4L16031  
(x2) | 1"x3 3/8"x12" (24x86x306)

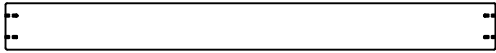

**H09** | FLOOR JOIST - W4L16032  
(x2) | 1"x3 3/8"x35 3/4" (24x86x908)



**H10** | ATTACHMENT BOARD - W4L16045  
(x1) | 1"x3 3/8"x27 7/8" (24x86x707)

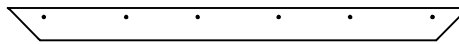

**J01** | ROOF RAFTER - W4L16033  
(x4) | 1"x2 3/8"x33 5/8" (24x60x854)



**K01** | WALL RAIL - W4L16034  
(x1) | 5/8"x5 1/4"x45 1/2" (16x134x1156)

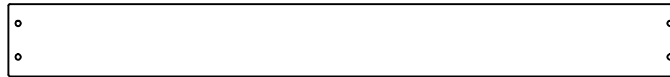

**K02** | BASE/SAND BOX BOARD - W4L16035  
(x3) | 5/8"x5 1/4"x49" (16x134x1244)

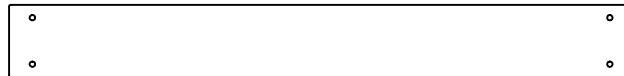

**K03** | GROUND BOARD - W4L16038  
(x2) | 5/8"x5 1/4"x45 1/2" (16x134x1156)

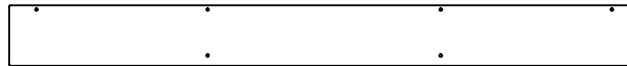

**L01** | OUTSIDE FILLER FLOOR BOARD - W4L16039  
(x3) | 5/8"x4 3/8"x46" (16x112x1168)

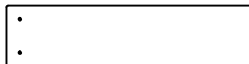

**L02** | WALL BOARD - W4L16040  
(x4) | 5/8"x4 3/8"x18" (16x112x456)

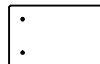

**L03** | WALL BOARD - W4L16041  
(x4) | 5/8"x4 3/8"x7" (16x112x178)

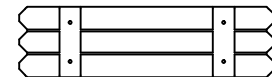

**L04** | WINDOW SHUTTER - W4L16042  
(x3) | 5/8"x4 3/8"x16" (16x112x406)

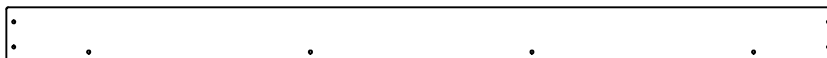

**M01** | ROOF CAP - W4L16043  
(x2) | 5/8"x3 3/8"x51 7/8" (16x86x1318)

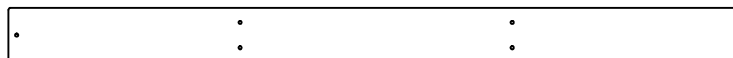

**M02** | FLOOR BOARD - W4L16055  
(x1) | 5/8"x3 3/8"x46" (16x86x1168)



# Owner's Manual - Parts Identification

## Wood Components (Not to Scale)

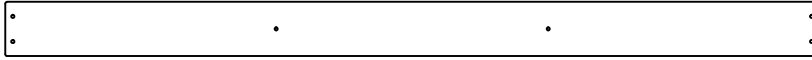

**M03** | FLOOR BOARD - W4L16063  
(x20) | 5/8"x3 3/8"x50 7/8" (16x86x1292)

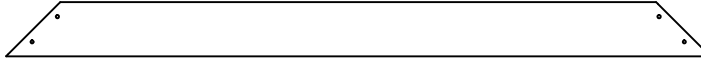

**M04** | GABLE BOARD - W4L16065  
(x2) | 5/8"x3 3/8"x44" (16x86x1118)

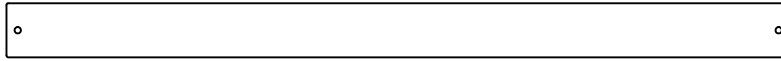

**M05** | WALL RAIL - W4L16066  
(x3) | 5/8"x3 3/8"x49" (16x86x1244)

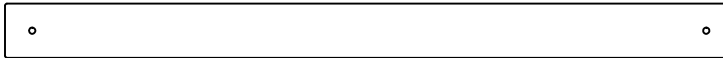

**M06** | WALL RAIL - W4L16067  
(x2) | 5/8"x3 3/8"x45 1/2" (16x86x1156)

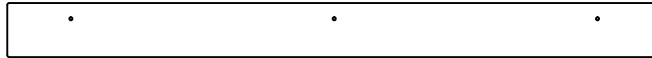

**M07** | WALL CAP - W4L16068  
(x2) | 5/8"x3 3/8"x40 7/8" (16x86x1038)

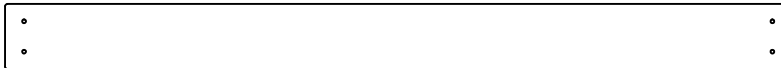

**M08** | WALL BOARD - W4L16074  
(x9) | 5/8"x3 3/8"x41" (16x86x1040)

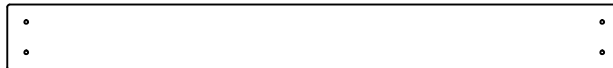

**M09** | WALL BOARD - W4L16075  
(x6) | 5/8"x3 3/8"x32" (16x86x812)



**M10** | WALL BOARD - W4L16044  
(x1) | 5/8"x3 3/8"x35" (16x86x888)



**M11** | WALL RAIL - W4L16047  
(x1) | 5/8"x3 3/8"x40 1/8" (16x86x1018)

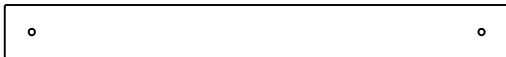

**M12** | WINDOW TRIM - W4L16048  
(x1) | 5/8"x3 3/8"x31 1/2" (16x86x800)

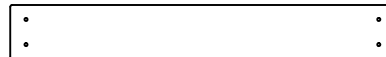

**M13** | WALL BOARD - W4L16049  
(x7) | 5/8"x3 3/8"x24" (16x86x610)

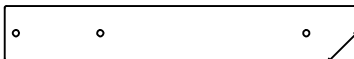

**M14** | PICNIC SEAT SUPPORT - W4L16050  
(x2) | 5/8"x3 3/8"x22" (16x86x558)

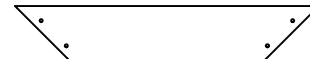

**M15** | GABLE BOARD - W4L16051  
(x2) | 5/8"x3 3/8"x19" (16x86x482)

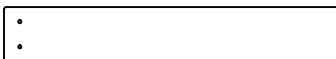

**M16** | WALL BOARD - W4L16052  
(x2) | 5/8"x3 3/8"x21" (16x86x532)

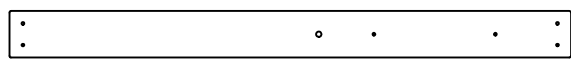

**M17** | WALL BOARD - W4L16090  
(x2) | 5/8"x3 3/8"x41" (16x86x1040)

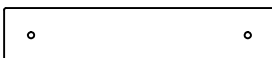

**M18** | WALL RAIL - W4L16053  
(x1) | 5/8"x3 3/8"x16 7/8" (16x86x430)

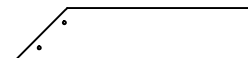

**M19** | GABLE BOARD - W4L16054  
(x4) | 5/8"x3 3/8"x15 1/4" (16x86x387)

# Owner's Manual - Parts Identification

## Wood Components (Not to Scale)

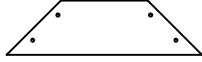

**M20** | GABLE BOARD - W4L16056  
(x2) | 5/8"x3 3/8"x12 1/4" (16x86x310)

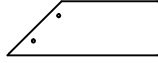

**M22** | GABLE BOARD - W4L16058  
(x4) | 5/8"x3 3/8"x9 1/2" (16x86x241)



**M24** | WALL BOARD - W4L16061  
(x7) | 5/8"x3 3/8"x29 5/8" (16x86x752)



**M26** | WALL BOARD - W4L16091  
(x2) | 5/8"x3 3/8"x29 5/8" (16x86x752)

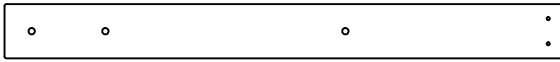

**M28** | WALL BOARD - W4L16064  
(x1) | 5/8"x3 3/8"x35" (16x86x888)

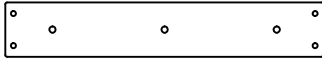

**M70** | SLIDE BED SUPPORT - W100935  
(x1) | 5/8"x3 3/8"x19 7/8" (16x86x505)



**M74** | ROCK WALL BOARD - W4L16071  
(x10) | 5/8"x3 3/8"x26 5/8" (16x86x675)



**M76** | ROCK WALL BOARD - W4L16073  
(x4) | 5/8"x3 3/8"x26 5/8" (16x86x675)

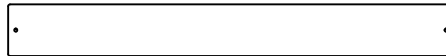

**M108** | TOP BOARD - W4L16046  
(x1) | 5/8"x3 1/4"x27 7/8" (16x82x707)



**N01** | FLOOR BOARD - W4L16076  
(x1) | 5/8"x2 3/8"x50 7/8" (16x60x1292)

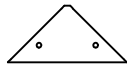

**N02** | MENDING PLATE - W4L16077  
(x2) | 5/8"x2 3/8"x5" (16x60x126)



**N04** | GABLE BOARD - W4L16079  
(x4) | 5/8"x2 3/8"x11 7/8" (16x60x301)

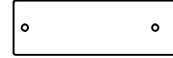

**M21** | WALL RAIL - W4L16057  
(x2) | 5/8"x3 3/8"x10 1/2" (16x86x268)



**M23** | WINDOW TRIM - W4L16059  
(x2) | 5/8"x3 3/8"x12 7/8" (16x86x328)

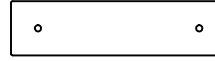

**M25** | TABLE SUPPORT - W4L16037  
(x2) | 5/8"x3 3/8"x13 1/2" (16x86x342)



**M27** | BOTTOM WALL BOARD - W4L16062  
(x13) | 5/8"x3 3/8"x21 3/8" (16x86x544)



**M29** | WALL BOARD - W4L16060  
(x2) | 5/8"x3 3/8"x5" (16x86x126)

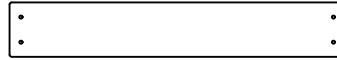

**M73** | REAR SUPPORT - W4L16070  
(x1) | 5/8"x3 3/8"x21" (16x86x532)



**M75** | ROCK WALL BOARD - W4L16072  
(x4) | 5/8"x3 3/8"x26 5/8" (16x86x675)

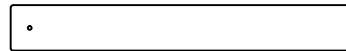

**N03** | WALL BOARD - W4L16078  
(x2) | 5/8"x2 3/8"x18" (16x60x456)



**N05** | WALL BOARD - W4L16080  
(x2) | 5/8"x2 3/8"x7" (16x60x178)

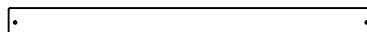

**N06** | FILLER BOARD - W4L16089  
(x1) | 5/8"x2 1/8"x26 5/8" (16x54x675)

# Owner's Manual - Parts Identification

## Wood Components (Not to Scale)



**O01** | WALL SUPPORT - W4L16081  
(x6) | 5/8"x1 3/8"x13" (16x34x330)

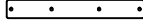

**O02** | WALL SUPPORT - W4L16082  
(x1) | 5/8"x1 3/8"x10" (16x34x254)



**O03** | SAFETY RAIL - W4L16083  
(x1) | 5/8"x1 3/8"x20 1/2" (16x34x520)



**O04** | WINDOW SHUTTER SLAT - W4L16084  
(x6) | 5/8"x1 3/8"x5 3/8" (16x34x136)

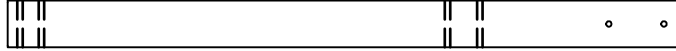

**SP50** | SWING BEAM SUPPORT - W4L16085  
(x1) | 3 3/8"x3 3/8"x49 3/8" (86x86x1254)



**T01** | SEAT SUPPORT - W4L16086  
(x4) | 1"x1 3/8"x4 3/8" (24x34x112)

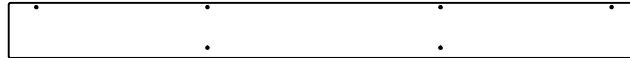

**Y01** | OUTSIDE FILLER FLOOR BOARD - W4L16087  
(x1) | 5/8"x4"x46" (16x102x1168)

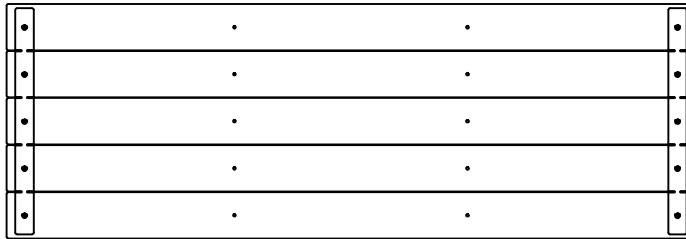

**FP1** | FLOOR PANEL - W2A03281  
(x1) | 1 5/8"x17 1/8"x50 1/4" (40x434x1276)

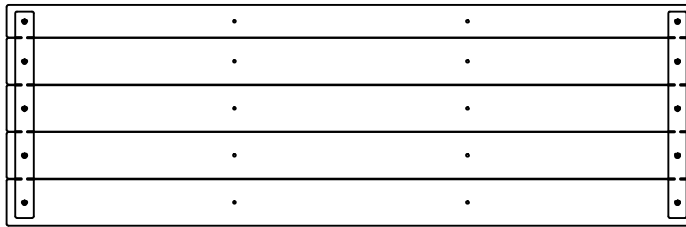

**FP2** | FLOOR PANEL - W2A03282  
(x1) | 1 5/8"x16 1/8"x50 1/4" (40x408x1276)



**RP1** | ROOF PANEL - W2A03279  
(x2) | 1 3/4"x19 1/4"x53 3/4" (45x490x1366)

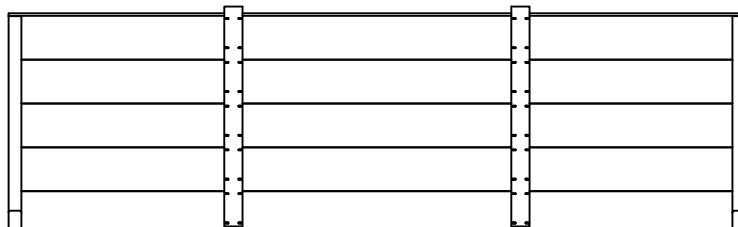

**RP2** | ROOF PANEL - W2A03280  
(x2) | 1 3/4"x16 1/4"x53 3/4" (45x417x1366)

# Owner's Manual - Parts Identification

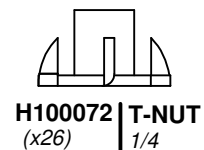
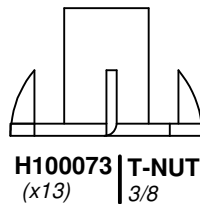
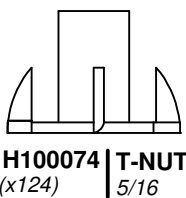
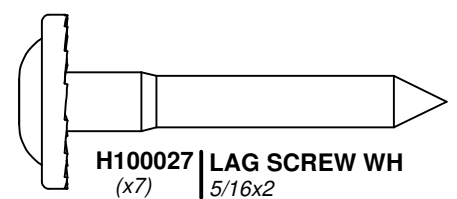
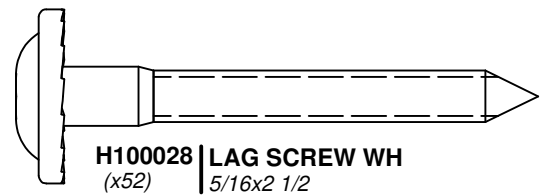
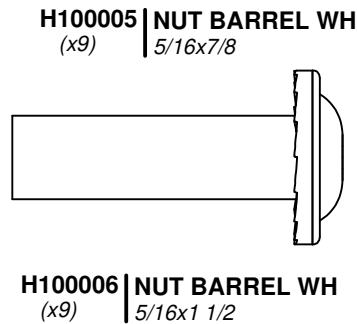
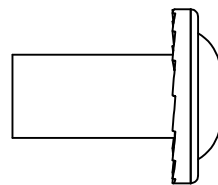
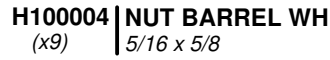
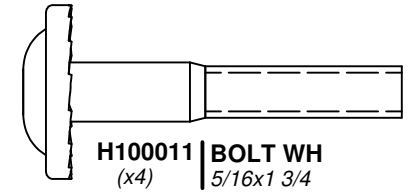
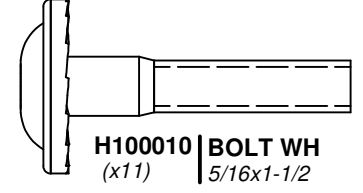
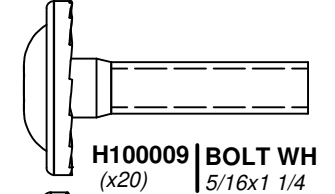
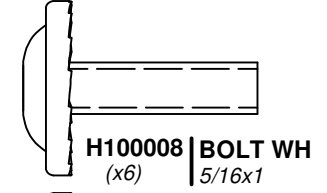
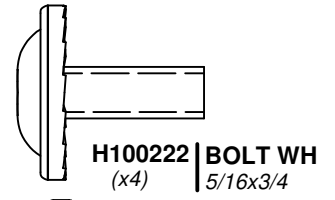
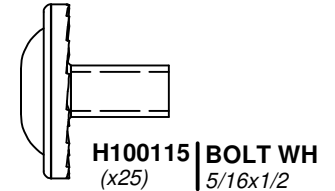
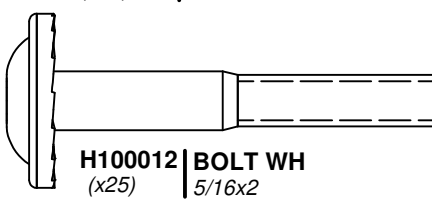
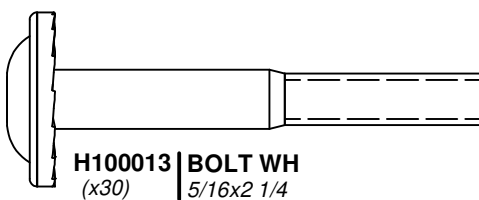
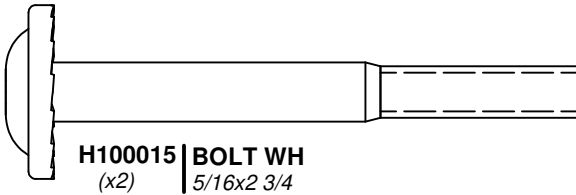
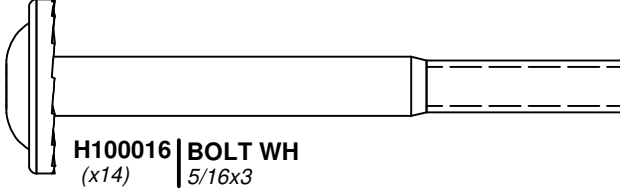
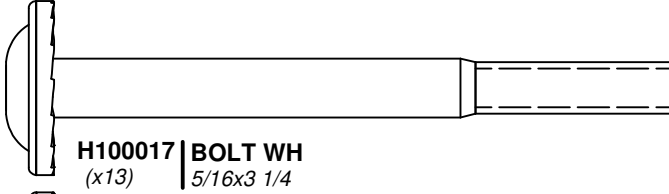
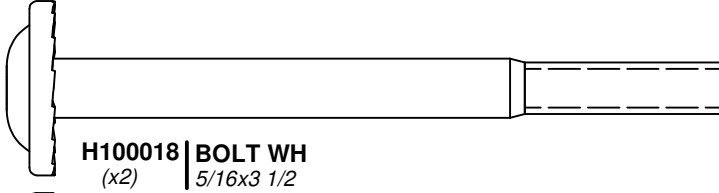
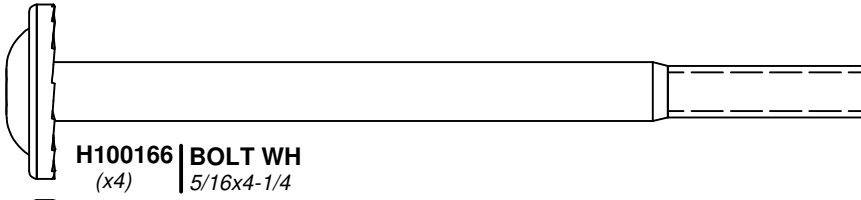
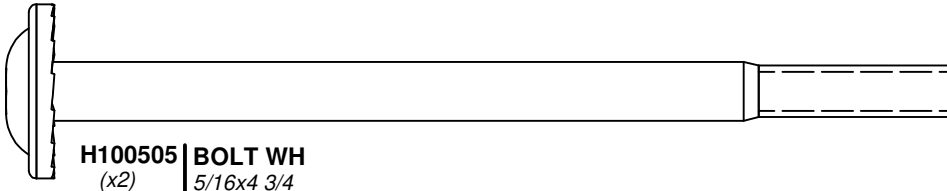

# Owner's Manual - Parts Identification

## Hardware Components

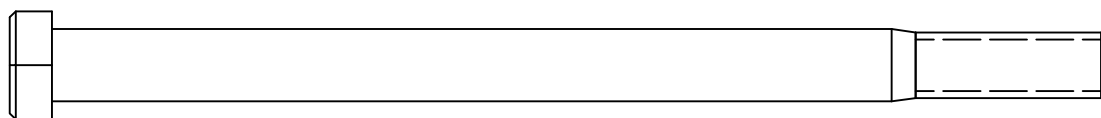

**H100654 | BOLT HEX**  
(x13) | 3/8x5-1/2

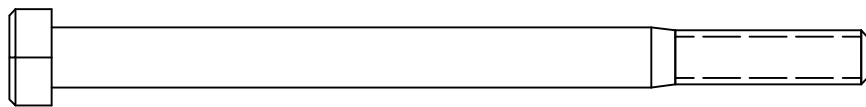

**H100054 | BOLT HEX**  
(x2) | 5/16x4 1/4



**H100063 | BOLT PTH**  
(x26) | 1/4x3/4

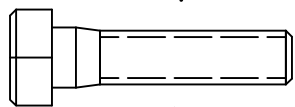

**H100042 | BOLT HEX**  
(x4) | 5/16x1 1/4

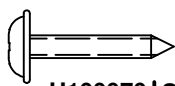

**H100070 | SCREW PWH**  
(x22) | 8x3/4

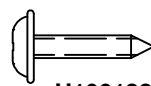

**H100128 | SCREW PWH**  
(x2) | 8x5/8

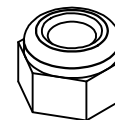

**H100110 | NUT LOCK**  
(x2) | 5/16

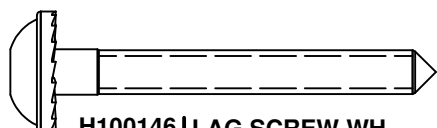

**H100146 | LAG SCREW WH**  
(x9) | 1/4x2

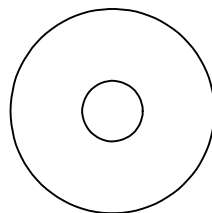

**H100105 | WASHER FLAT**  
(x9) | 8x27

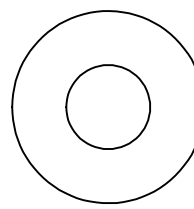

**H100102 | WASHER FLAT**  
(x13) | 11x25

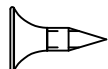

**H100124 | SCREW PFH**  
(x4) | 8 x 1/2

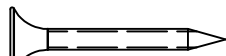

**H100088 | SCREW PFH**  
(x305) | 8x1 1/8

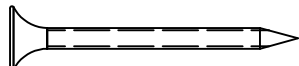

**H100086 | SCREW PFH**  
(x282) | 8x1 1/2



**H100089 | SCREW PFH**  
(x65) | 8x1 3/4

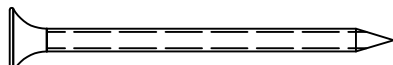

**H100111 | SCREW PFH**  
(x7) | 8x2

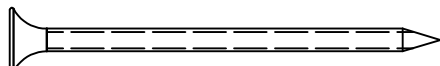

**H100091 | SCREW PFH**  
(x26) | 8x2 1/4

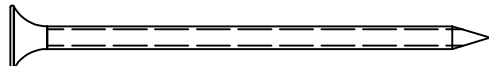

**H100090 | SCREW PFH**  
(x73) | 8x2 1/2"

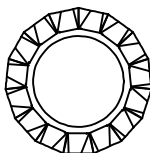

**H100031 | WASHER LOCK EXT**  
(x12) | 12x19

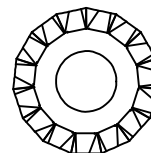

**H100030 | WASHER LOCK EXT**  
(x155) | 8x19

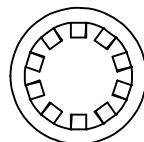

**H100107 | WASHER LOCK INT**  
(x13) | 10x18

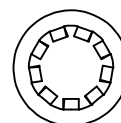

**H100108 | WASHER LOCK INT**  
(x26) | 8x15

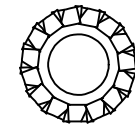

**H100138 | WASHER LOCK EXT**  
(x9) | 6x15

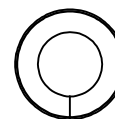

**H100095 | WASHER SPLIT**  
(x4) | 5/16



**H100764 | SCREW SETTER**  
(x1)

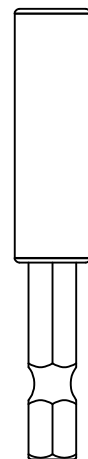

**H101100 | MAGNETIC DRIVER**  
(x1)

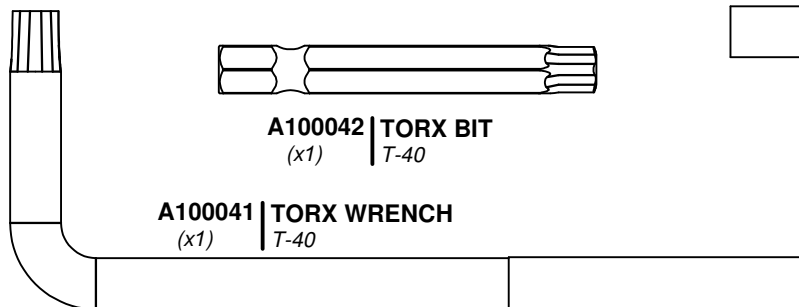

**A100041 | TORX WRENCH**  
(x1) | T-40

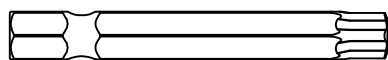

**A100042 | TORX BIT**  
(x1) | T-40

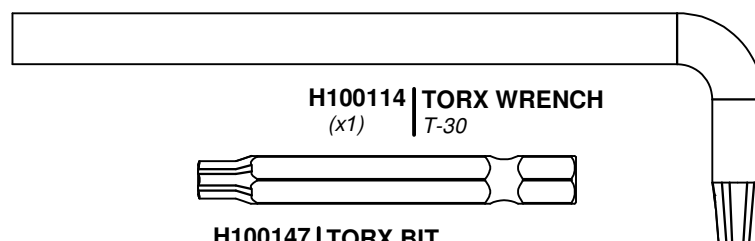

**H100114 | TORX WRENCH**  
(x1) | T-30

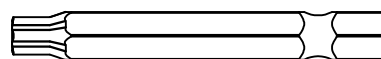

**H100147 | TORX BIT**  
(x1) | T-30



# Owner's Manual - Parts Identification

## Accessory Components (Not to Scale)



A100035 | SLIDE BED 10' LIGHT GREEN  
(x1)

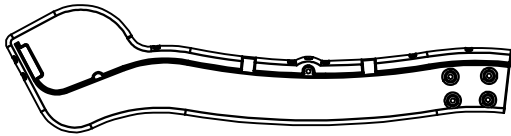

A6P00484 | SLIDE RAIL 10'  
BOTTOM RIGHT GREEN  
(x1)

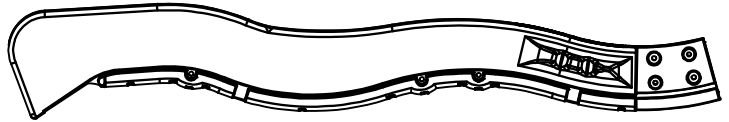

A6P00486 | SLIDE RAIL 10'  
TOP RIGHT GREEN  
(x1)

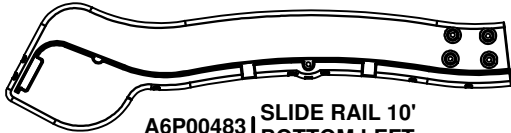

A6P00483 | SLIDE RAIL 10'  
BOTTOM LEFT GREEN  
(x1)

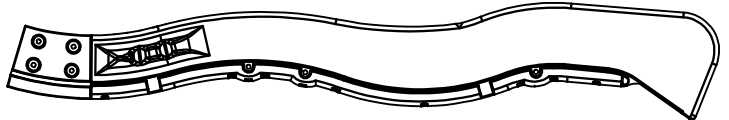

A6P00485 | SLIDE RAIL 10'  
TOP LEFT GREEN  
(x1)

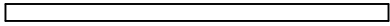

A6P00487 | SLIDE TUBE SUPPORT  
(x4)

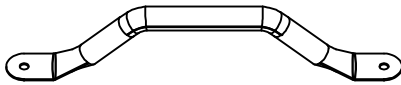

A100118 | HAND GRIP  
METAL GREEN  
381 c/c  
(x4)

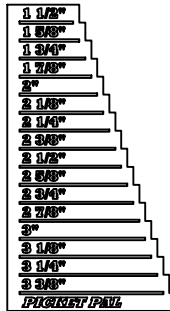

A6P00410 | PICKET PAL  
(x1)

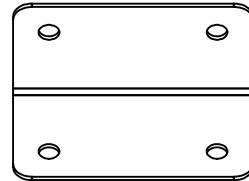

A100140 | L BRACKET  
(x2) | 66x66x127



A4M01046 | L BRACKET  
(x3) | 2.5x38x55x55

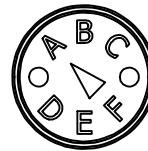

A100314 | "A" REVISION  
(x1) TAG

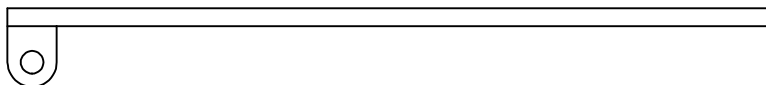

A4M00527 | GROUND STAKE  
(x2) REBAR



A100178 | AUGER GROUND  
(x6) STAKE

# Owner's Manual - Parts Identification

## Accessory Components (Not to Scale)

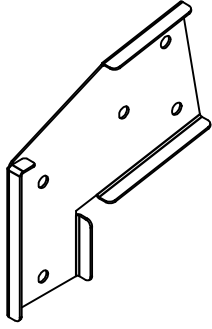

A100325 | SWING BEAM  
(x1) | EXTENSION  
BRACKET-LEFT

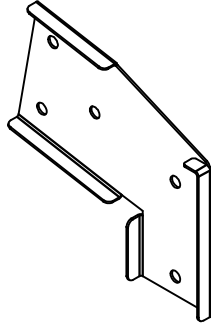

A100326 | SWING BEAM  
(x1) | EXTENSION  
BRACKET-RIGHT

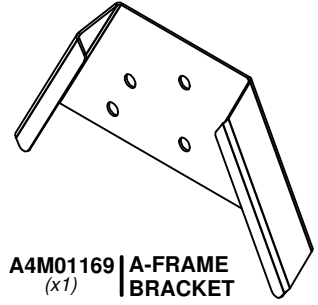

A4M01169 | A-FRAME  
(x1) | BRACKET



A100027 | SWING SEAT GREEN 26"  
(x2)

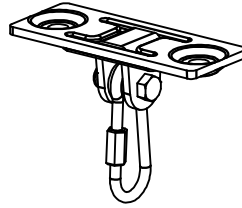

A4M00505 | SWING HANGER  
(x6)

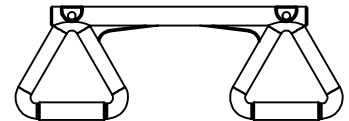

A6P00034 | TRAPEZE  
(x1) | YELLOW

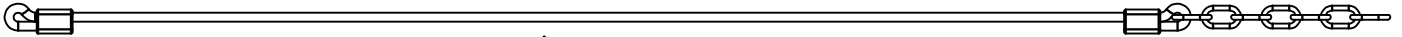

A100183 | ROPE-CHAIN GREEN 57"  
(x4)

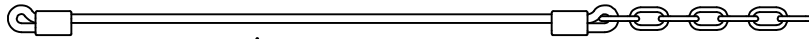

A100083 | ROPE-CHAIN GREEN 33"  
(x2)

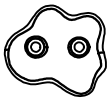

A6P00036 | GREEN HC ROCK #1  
(x6)

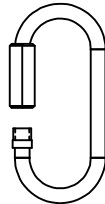

A100069 | QUICK LINK  
(x6)

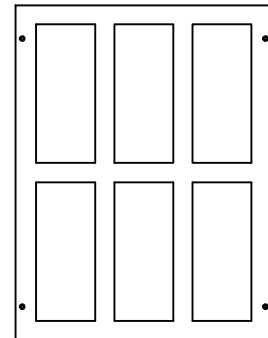

A100010 | PLASTIC WINDOW BYD GREEN 343x444.5  
(x2)



A6P00037 | GREEN HC ROCK #2  
(x6)



A100164 | BYD ID TAG  
(x1)

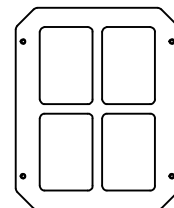

A100146 | WINDOW  
(x3) | 216x267 GREEN

# PRE-ASSEMBLY STEP 1 - SORTING PARTS

It is critical for ease of assembly that you take the time to sort and organize the wood and hardware.

---

## WOOD PARTS:

- Organize wood parts by the three-digit, alpha-numeric number stamped on each board (ex. P01).
- If there are multiple boards with the same stamped number, stack those pieces together.
- Stamps can be found on the flat surface of the boards or on the end of the boards.
- Allow yourself plenty of room - the wood pieces can take up a significant amount of space.

**NOTE: CARTONS ARE NOT ORGANIZED BY BOARD NUMBER.**

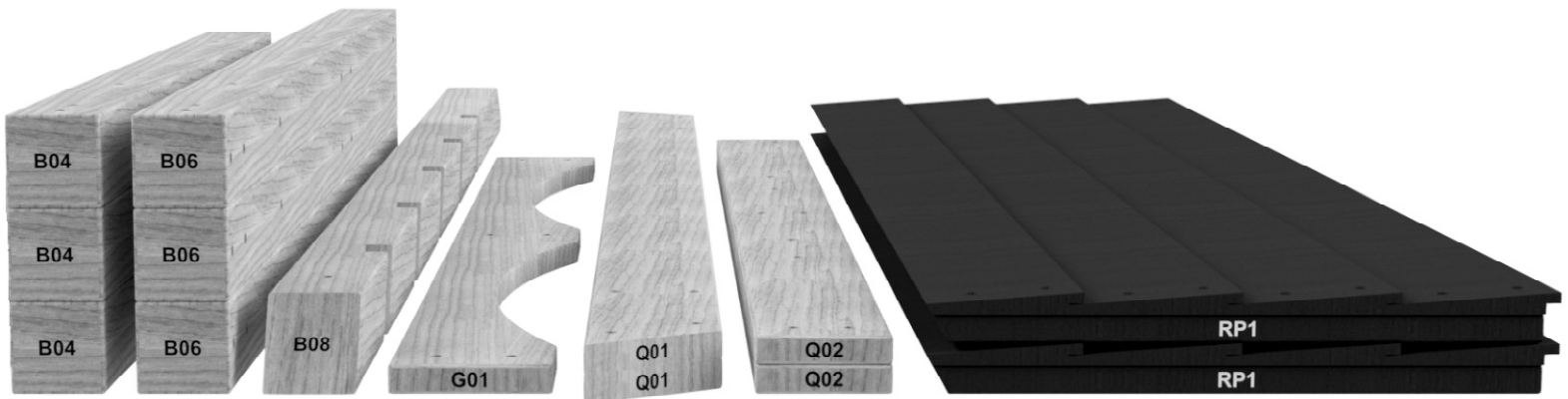

## HARDWARE PARTS:

- We recommend that you have a separate table to organize the hardware.
- Hardware bags are printed with a seven-digit, alpha-numeric part number.
- You can organize your hardware by part number or group by hardware type (i.e. bolts, nuts, etc.).
- During assembly you only need to reference the last four digits of the number.

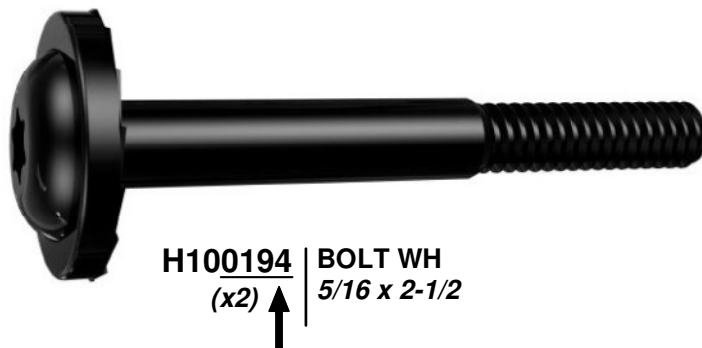

# PRE-ASSEMBLY STEP 2 - TOOLS REQUIRED



*Cordless Drill or  
Electric Drill*



*Drill Attachments:  
Phillips Head*



*1/8", 3/16", 3/8" & 7/16"  
Drill Bits*



*Phillips Screw Driver*



*Open End Wrenches 1/2" & 9/16"*



*3/8" Drive Ratchet, 1/2" &  
9/16" STD Sockets 1/2" & 9/16"  
Deep Sockets*



*Claw Hammer*



*Rubber Mallet - Optional*



*Tape Measure*

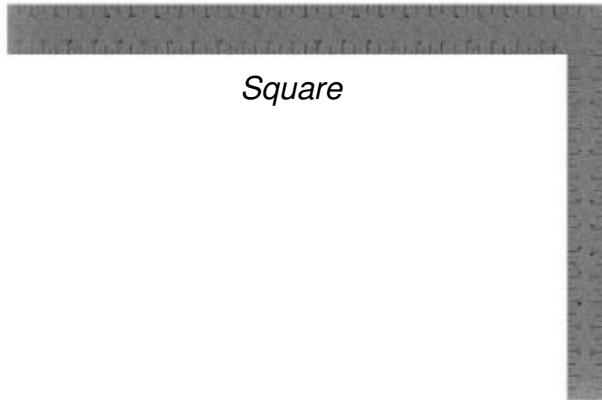

*Square*





*Level 24"*

# PRE-ASSEMBLY STEP 3 - CHOOSE YOUR ASSEMBLY METHOD



There are several types of assembly instructions available to you.

1. *Printed Assembly Manual included with your set*
2. *BILT APP - 3D interactive instructions*
3. *Combination of the Printed Manual and BILT APP (Note: Step numbers can differ between the two methods)*

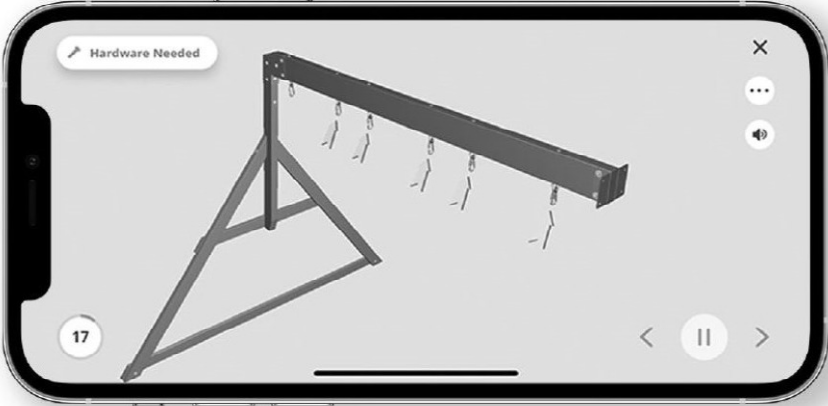

## Scan for easy 3D instructions

Download the BILT app  
before you begin



The image shows a smartphone screen displaying the BILT app interface. The screen features a 3D assembly diagram of a metal frame with a horizontal beam and several hanging components. The interface includes a 'Hardware Needed' button at the top left, a close button (X) at the top right, a menu button (three dots) and a volume icon below it, and a page number '17' in a circle at the bottom left. At the bottom center, there are navigation arrows and a pause button.

# STEP 1 - LADDER

QTY	PART NUMBER	DESCRIPTION
8	H100091	SCREW PFH 8x2 1/4



**E74 | LEFT UPRIGHT - W4L16028**  
*(x1) | 1 3/8"x3 3/8"x50 3/4" (36x86x1290)*



**H07 | LADDER RUNG - W4L16030**  
*(x4) | 15/16"x3 3/8"x18 7/8" (24x86x480)*

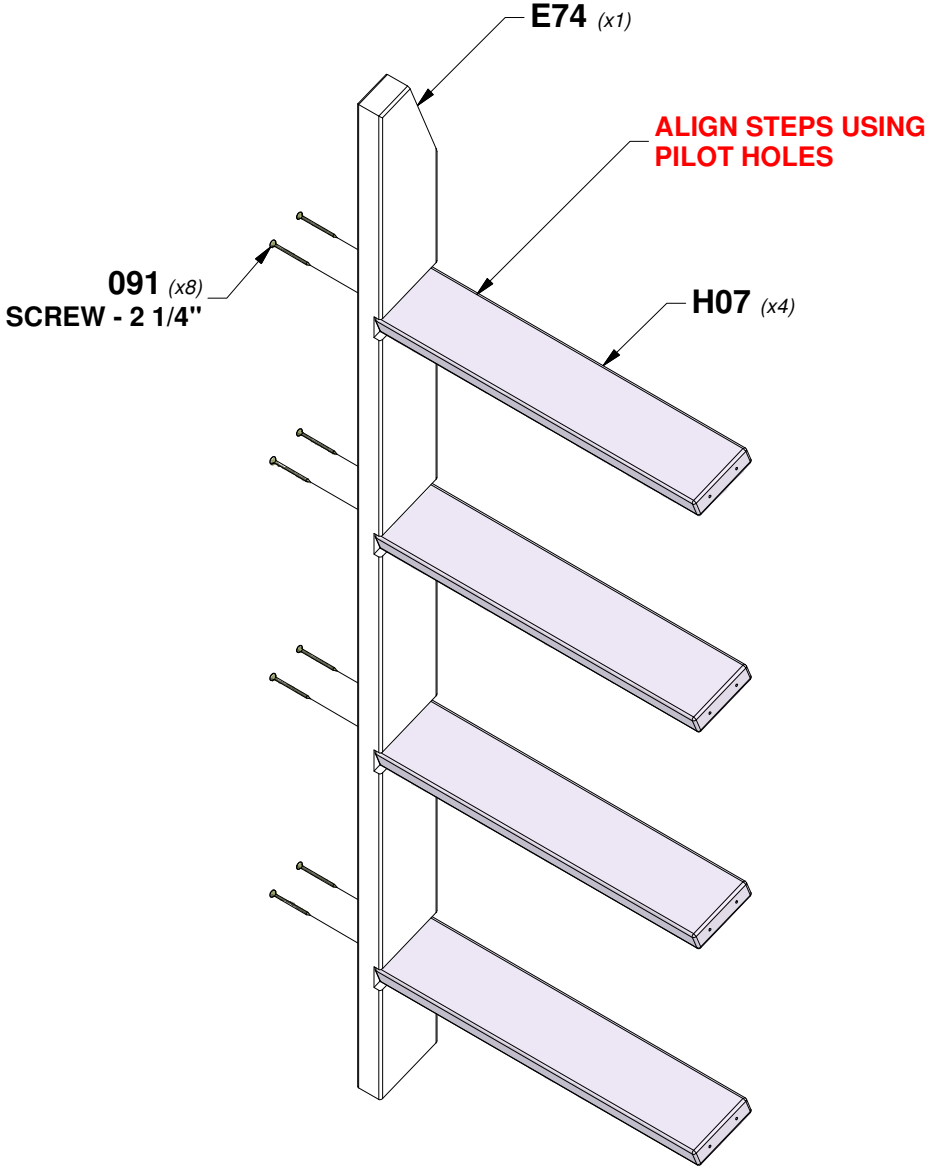

# STEP 2 - LADDER

QTY	PART NUMBER	DESCRIPTION
8	H100091	SCREW PFH 8x2 1/4



**E75** | RIGHT UPRIGHT - W4L16029  
(x1) | 1 3/8"x3 3/8"x50 3/4" (36x86x1290)

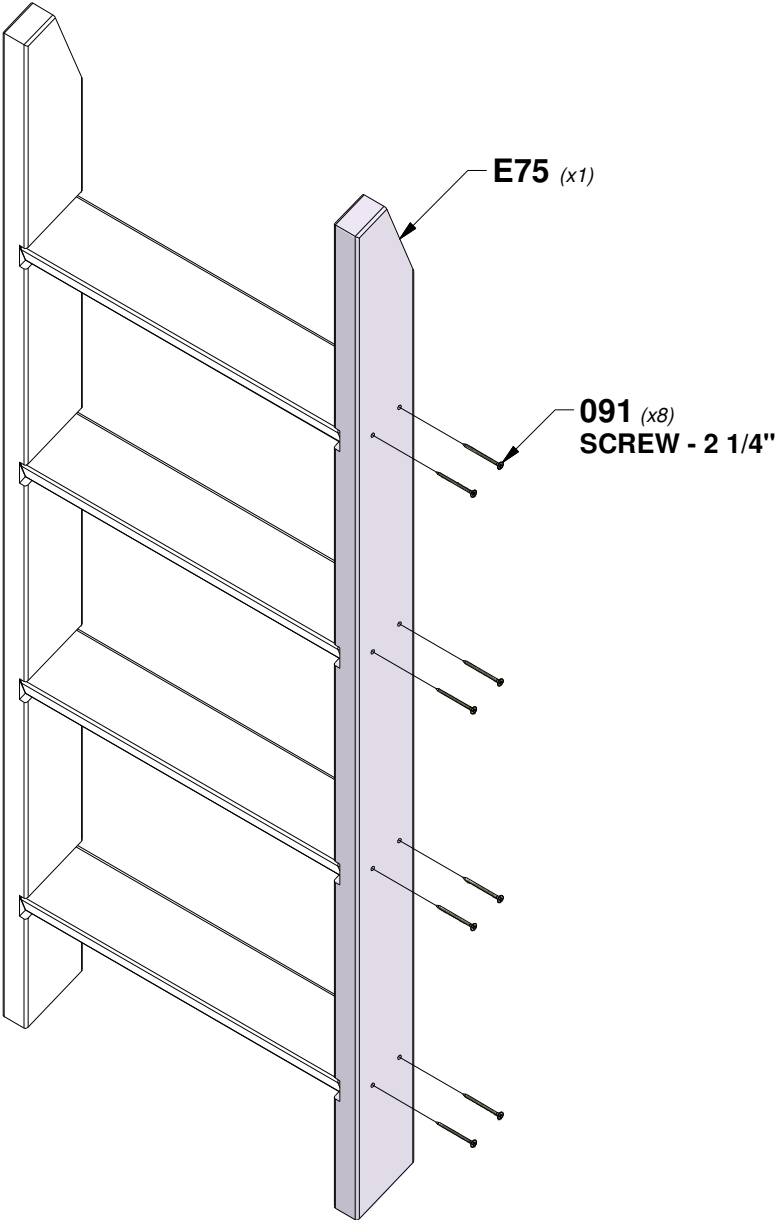

# STEP 3 - LADDER

QTY	PART NUMBER	DESCRIPTION
4	H100091	SCREW PFH 8x2 1/4

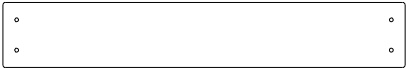

**M73** REAR SUPPORT - W4L16070  
(x1) 5/8"x3 3/8"x21" (16x86x532)

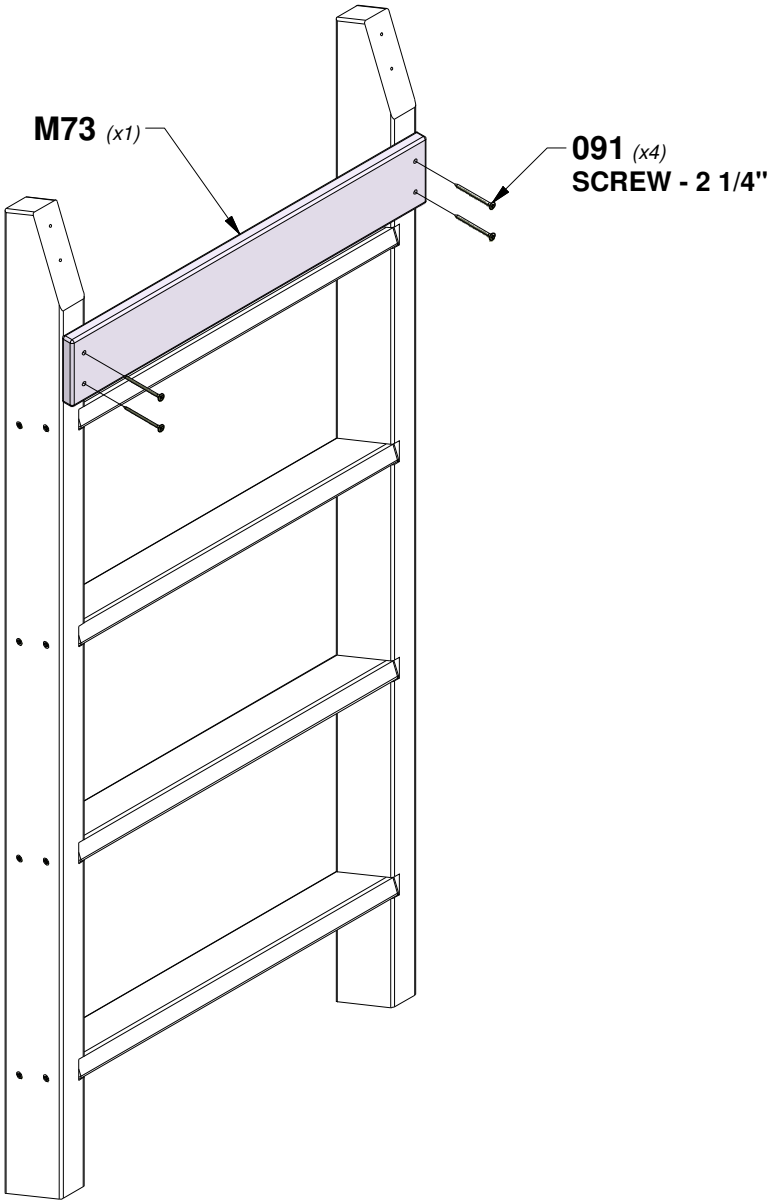



# STEP 4 - LADDER

QTY	PART NUMBER	DESCRIPTION
4	H100091	SCREW PFH 8x2 1/4



**H06** LADDER MOUNT - W4L16088  
(x1) 1"x3 3/8"x21" (24x86x532)

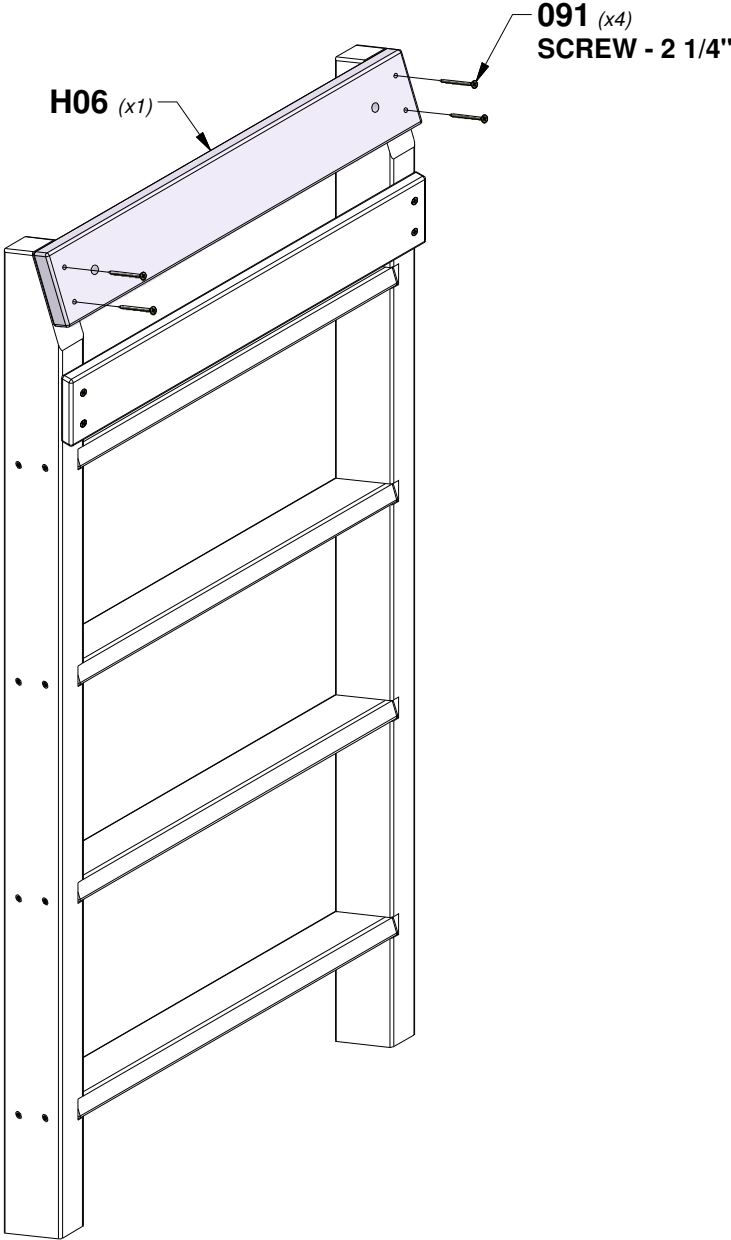

# STEP 1 - ROCK WALL

QTY	PART NUMBER	DESCRIPTION
24	H100063	BOLT PTH 1/4x3/4
24	H100072	T-NUT 1/4
24	H100108	WASHER LOCK INT 8x15

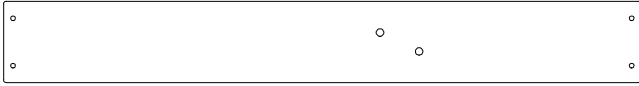

**M75** | ROCK WALL BOARD - W4L16072  
(x4) 5/8"x3 3/8"x26 5/8" (16x86x675)



**M76** | ROCK WALL BOARD - W4L16073  
(x4) 5/8"x3 3/8"x26 5/8" (16x86x675)

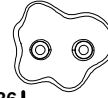

**A6P00036** | GREEN HC ROCK #1  
(x6)

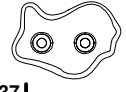

**A6P00037** | GREEN HC ROCK #2  
(x6)

**TIP:**  
INSTALL T-NUTS IN WOOD FIRST

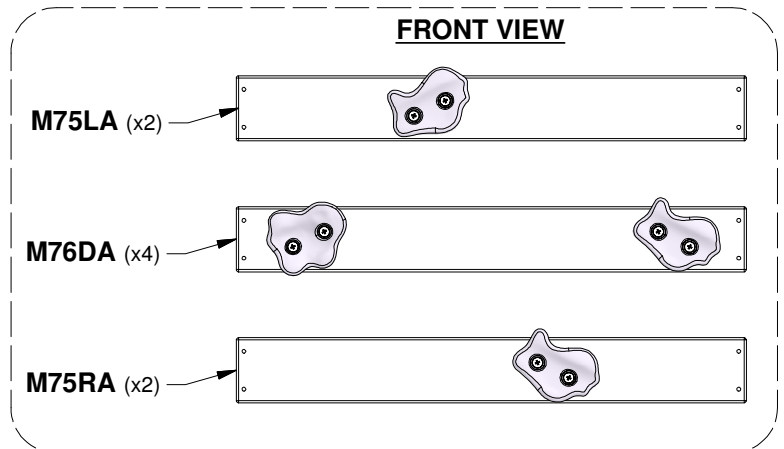
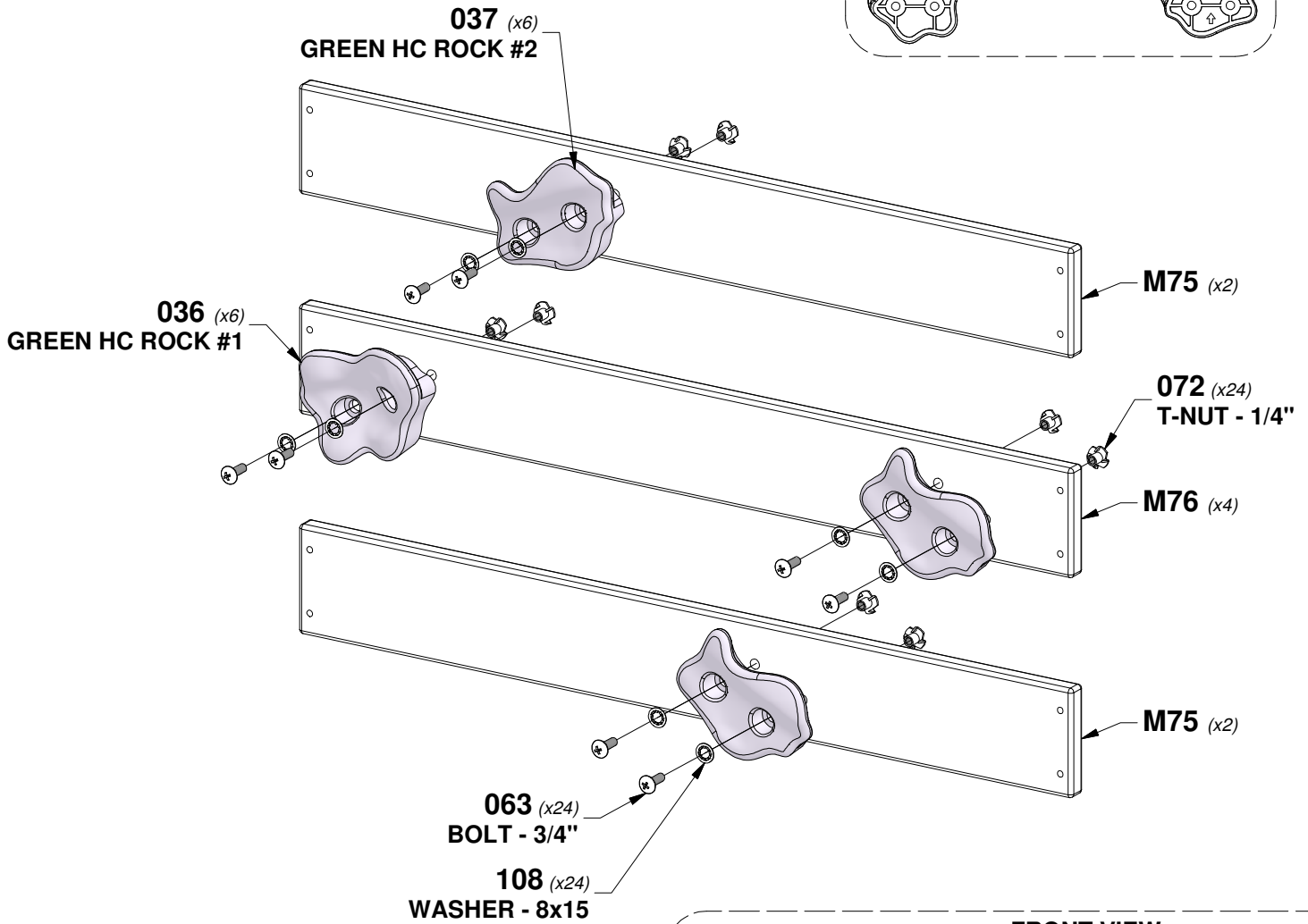
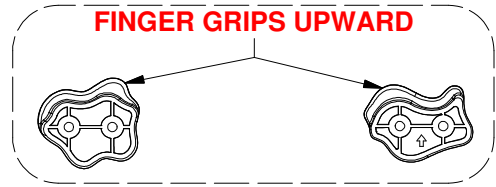

# STEP 2 - ROCK WALL

QTY	PART NUMBER	DESCRIPTION
74	H100086	SCREW PFH 8x1-1/2"

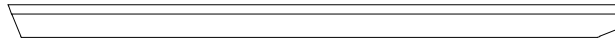
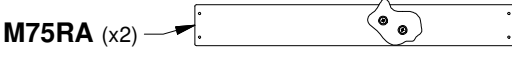
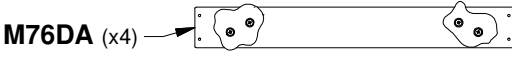

**E72** | LEFT RAIL - W4L16007  
(x1) | 1 3/8"x3 3/8"x64 1/2" (36x86x1640)

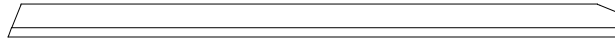

**E73** | RIGHT RAIL - W4L16008  
(x1) | 1 3/8"x3 3/8"x64 1/2" (36x86x1640)

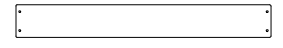

**M74** | ROCK WALL BOARD - W4L16071  
(x10) | 5/8"x3 3/8"x26 5/8" (16x86x675)



**N06** | FILLER BOARD - W4L16089  
(x1) | 5/8"x2 1/8"x26 5/8" (16x54x675)

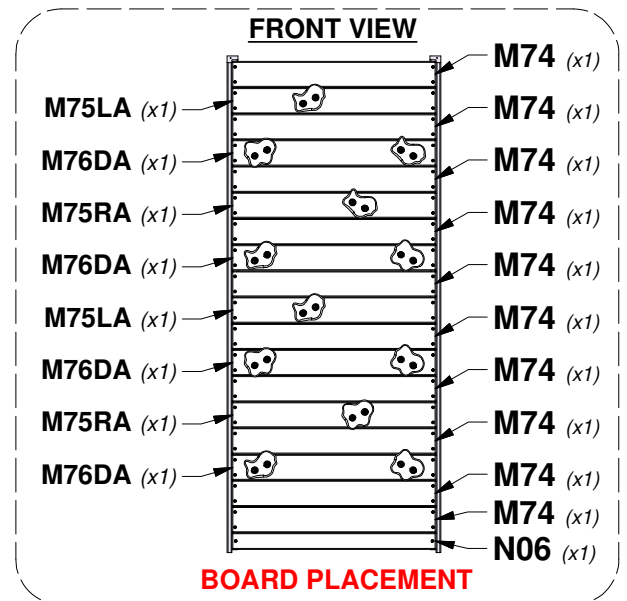
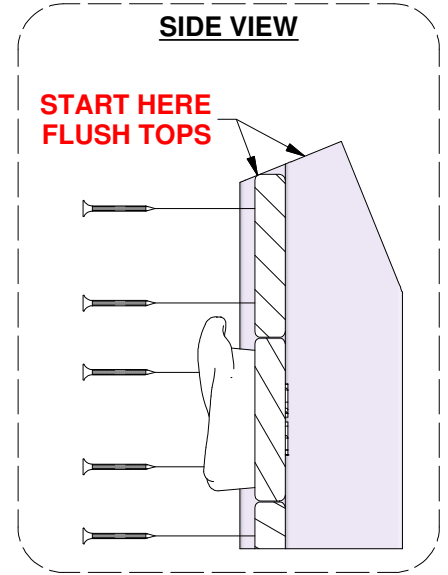
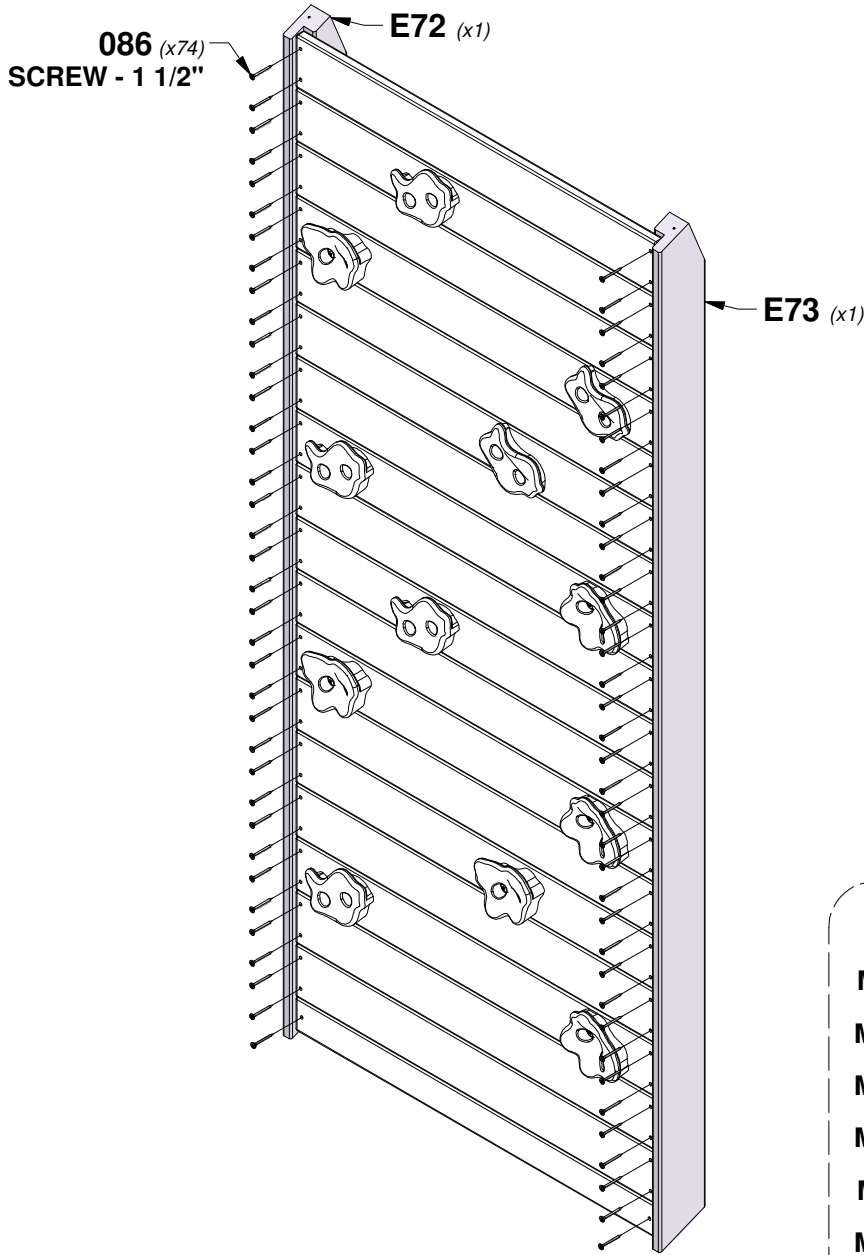

# STEP 3 - ROCK WALL

QTY	PART NUMBER	DESCRIPTION
2	H100086	SCREW PFH 8x1-1/2"



**M108** | TOP BOARD - W4L16046  
(x1) | 5/8"x3 1/4"x27 7/8" (16x82x707)

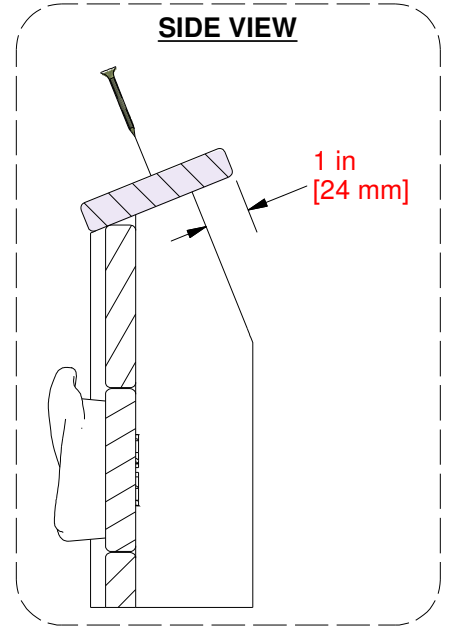
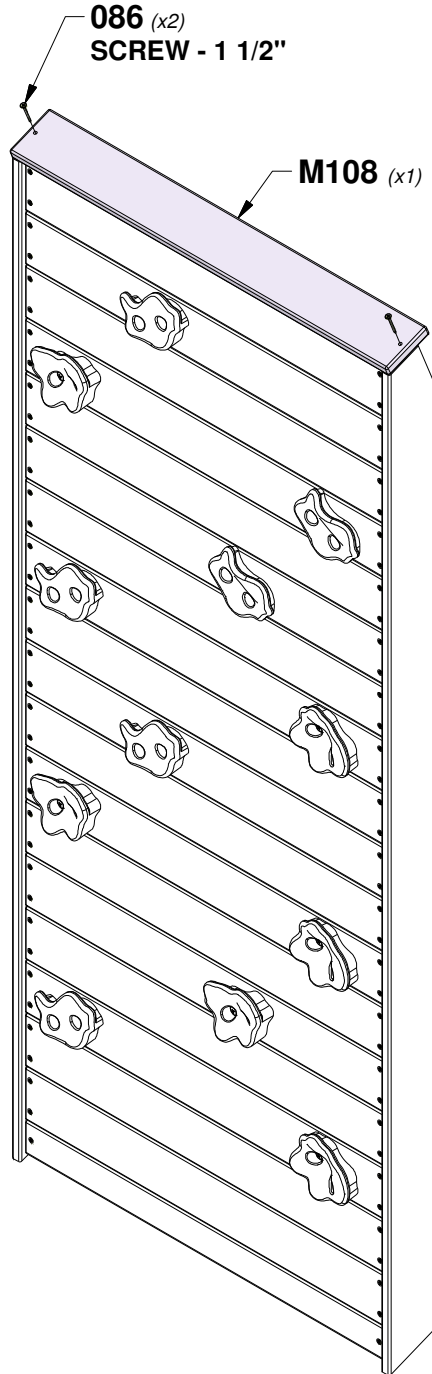

# STEP 4 - ROCK WALL

QTY	PART NUMBER	DESCRIPTION
2	H100074	T-NUT 5/16
4	H100111	SCREW PFH 8x2"



**H10 | ATTACHMENT BOARD - W4L16045**  
 (x1) 1"x3 3/8"x27 7/8" (24x86x707)

**TIP:**  
**INSTALL T-NUTS IN WOOD FIRST**

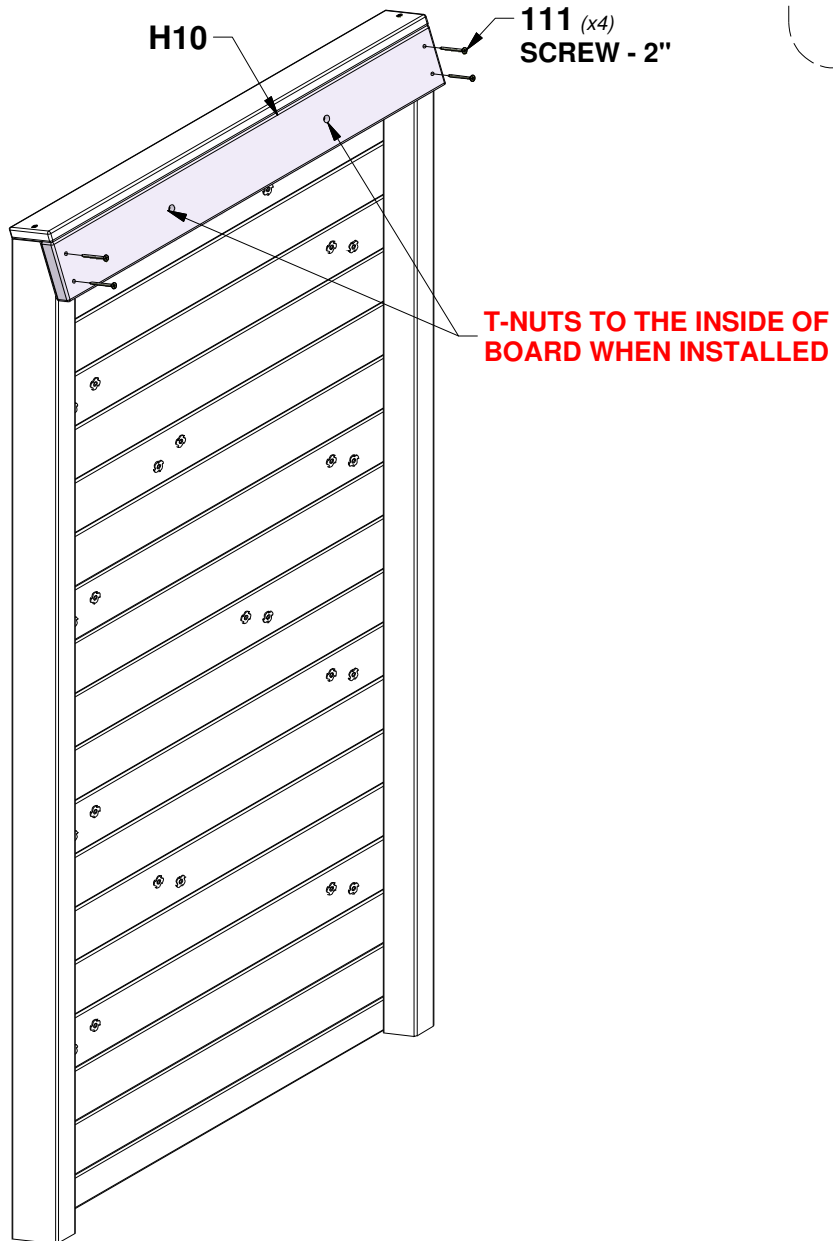
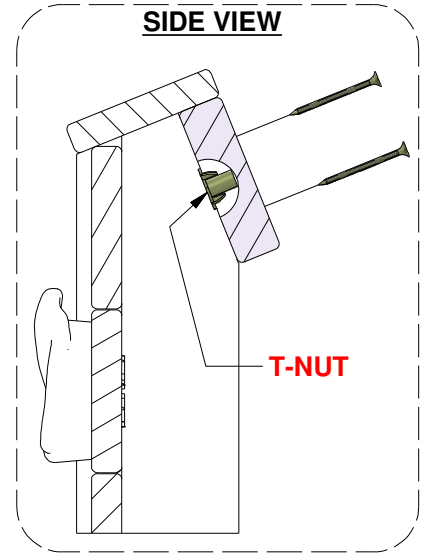
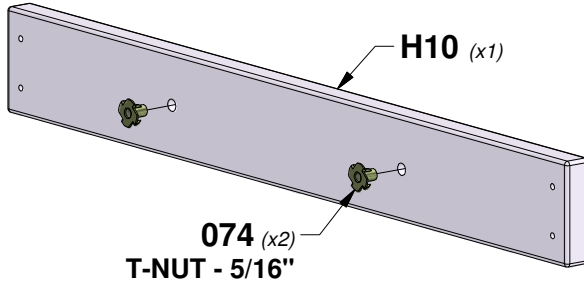

# STEP 1 - SWING BEAM

QTY	PART NUMBER	DESCRIPTION
3	H100005	NUT BARREL WH 5/16x7/8
3	H100016	BOLT WH 5/16x3
2	H100054	BOLT HEX 5/16x4 1/4
4	H100105	WASHER FLAT 8x27
2	H100110	NUT LOCK 5/16



**A50 | SWING BEAM - W4L1598**  
(x1) | 3 3/8"x5 1/4"x89 1/2" (86x134x2274)

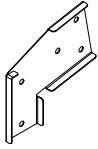

**A100325 | SWING BEAM  
EXTENSION  
BRACKET-LEFT**  
(x1)

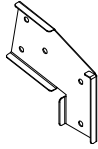

**A100326 | SWING BEAM  
EXTENSION  
BRACKET-RIGHT**  
(x1)



**A100140 | L BRACKET**  
(x2) | 66x66x127

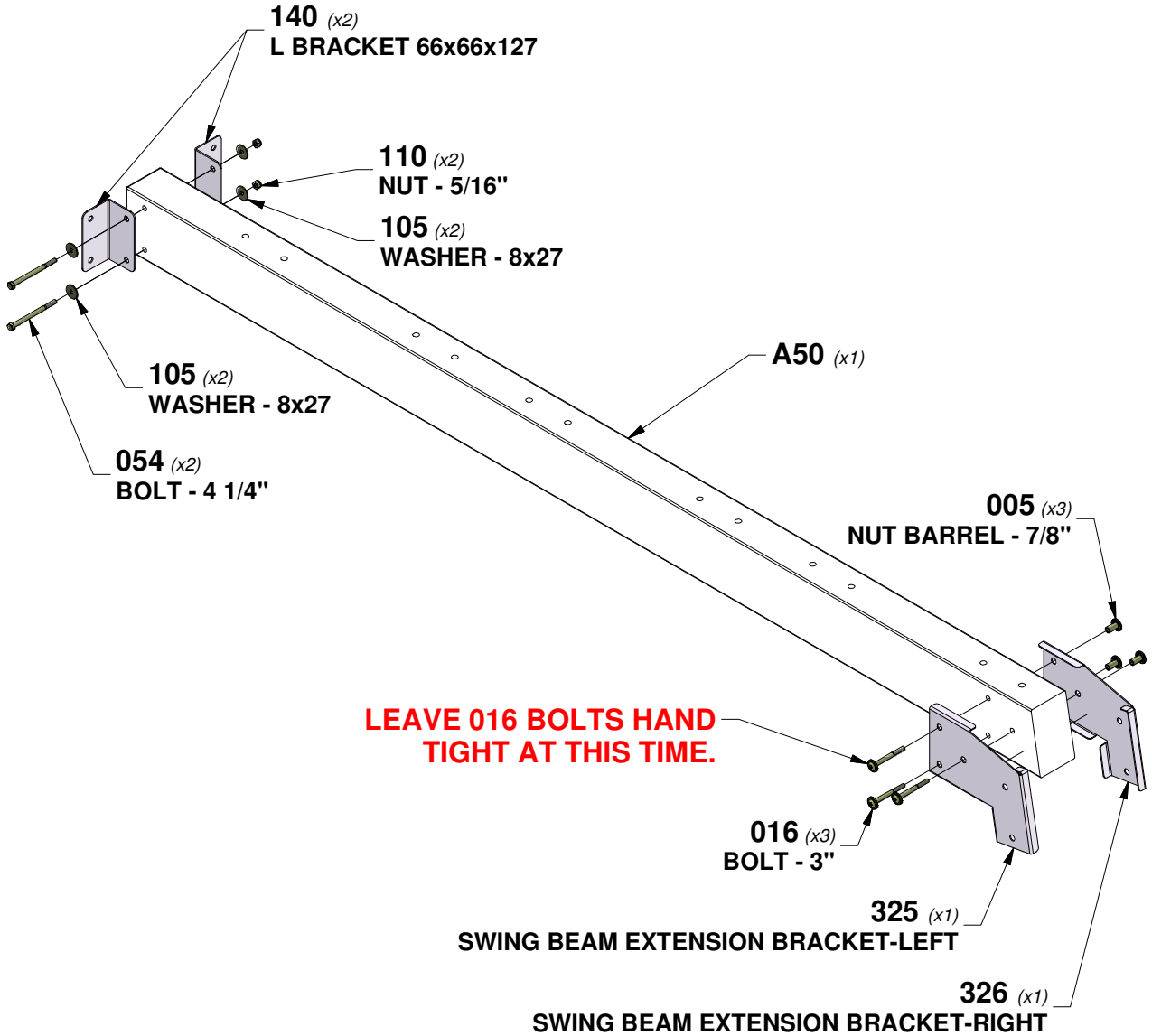

# STEP 2 - SWING BEAM

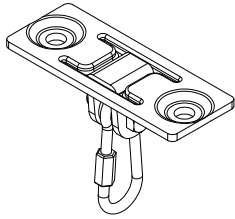

**A4M00505** | SWING HANGER  
(x6)

QTY	PART NUMBER	DESCRIPTION
12	H100073	T-NUT 3/8
12	H100102	WASHER FLAT 11x25
12	H100107	WASHER LOCK INT 10x18
12	H100654	BOLT HEX 3/8x5-1/2

**TIP:**  
**INSTALL T-NUTS IN WOOD FIRST**

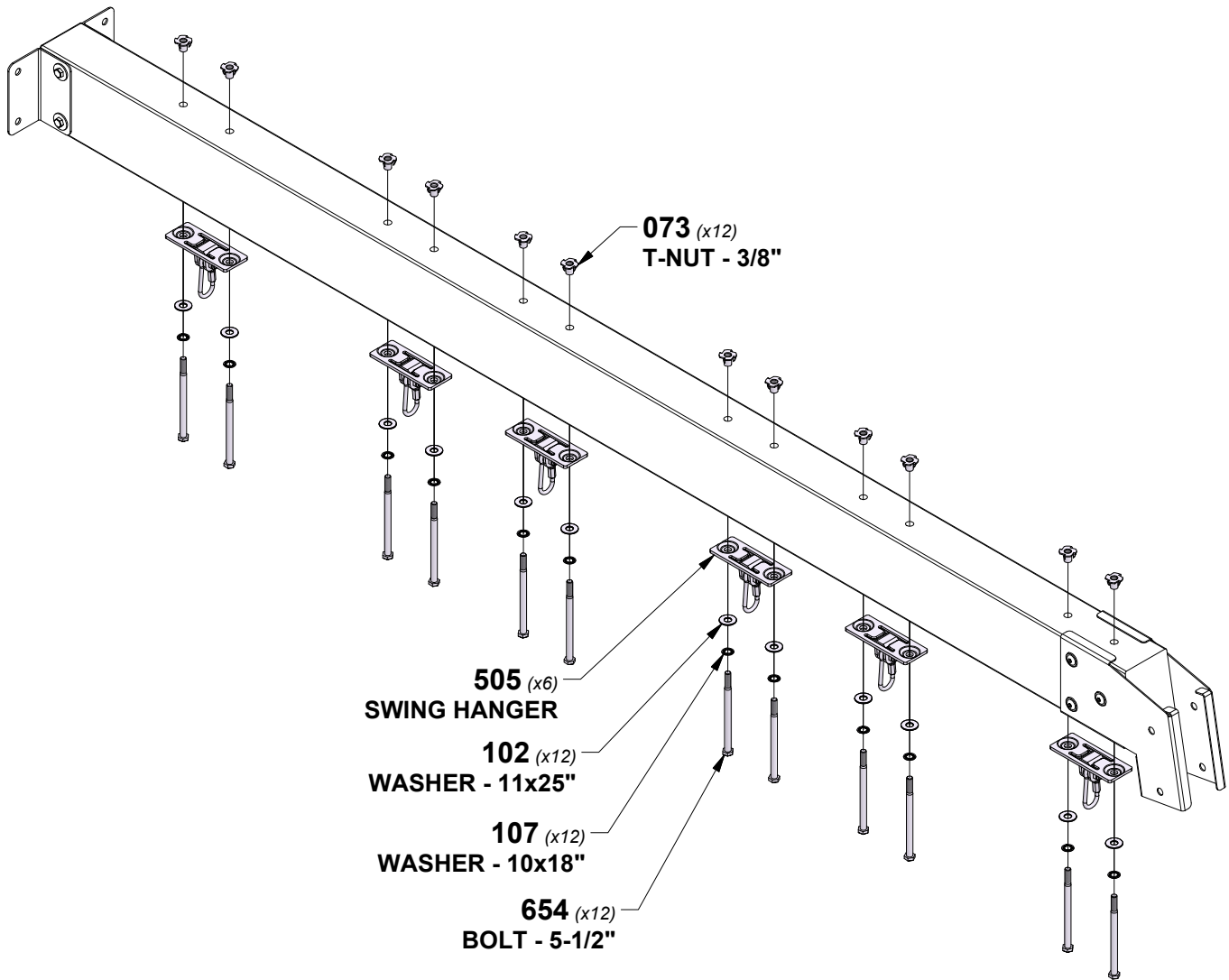

# STEP 3 - SWING BEAM

QTY	PART NUMBER	DESCRIPTION
4	H100124	SCREW PFH 8x1/2



A100164 (x1) BYD ID TAG  
(LARGE) AGES  
3-10

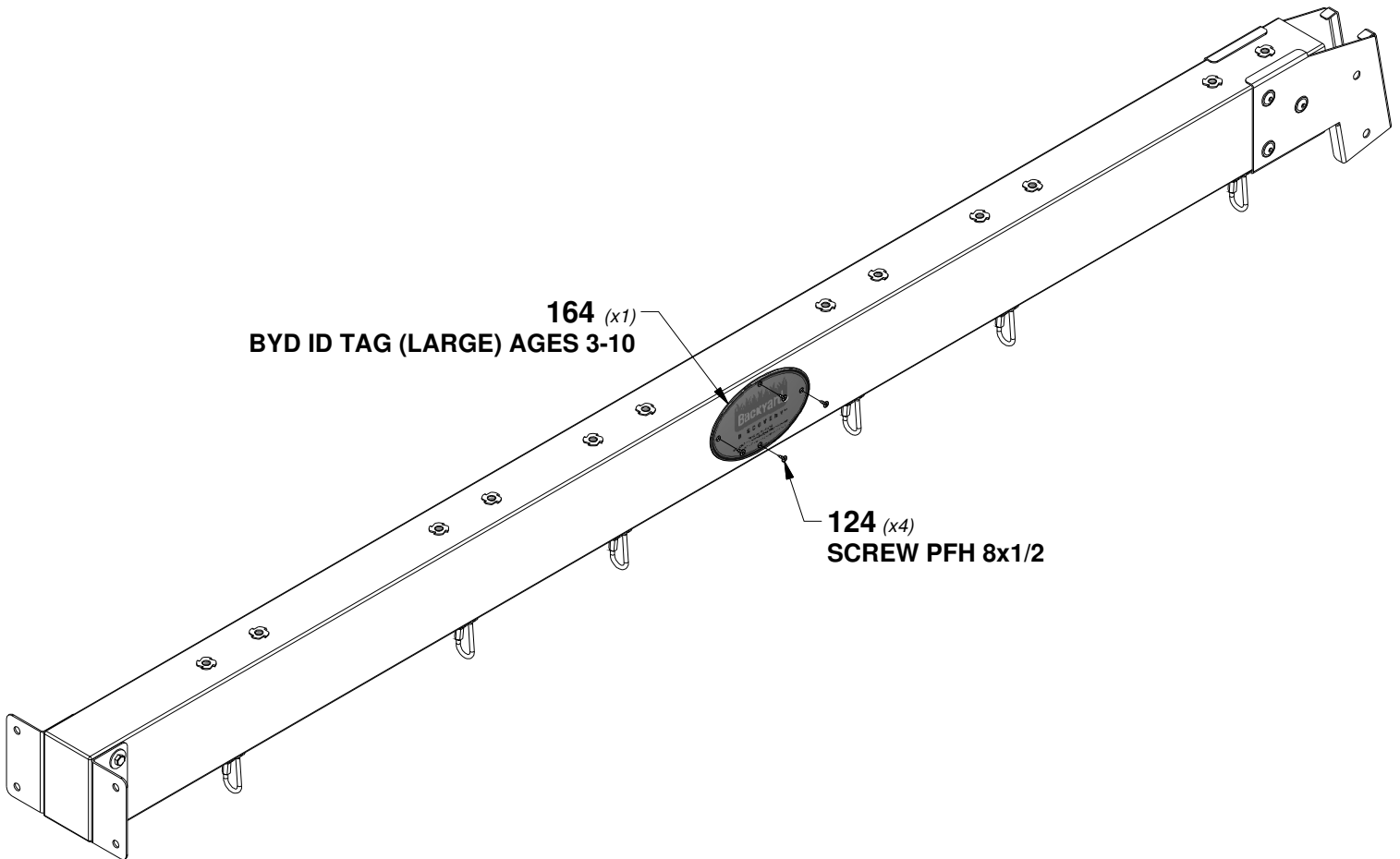

164 (x1)  
BYD ID TAG (LARGE) AGES 3-10

124 (x4)  
SCREW PFH 8x1/2



# STEP 4 - SWING BEAM

QTY	PART NUMBER	DESCRIPTION
4	H100009	BOLT WH 5/16x1 1/4
2	H100018	BOLT WH 5/16x3 1/2
6	H100074	T-NUT 5/16



**SP50** | SWING BEAM SUPPORT - W4L16085  
(x1) | 3 3/8"x3 3/8"x49 3/8" (86x86x1254)

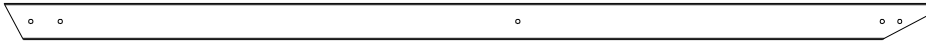

**E51** | ANGLE BRACE - W4L16004  
(x2) | 1 7/16"x3 3/8"x87 3/16" (36x86x2214)

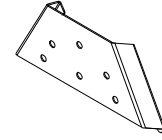

**A4M01169** | A-FRAME BRACKET  
(x1)

**TIP:**  
**INSTALL T-NUTS IN WOOD FIRST**

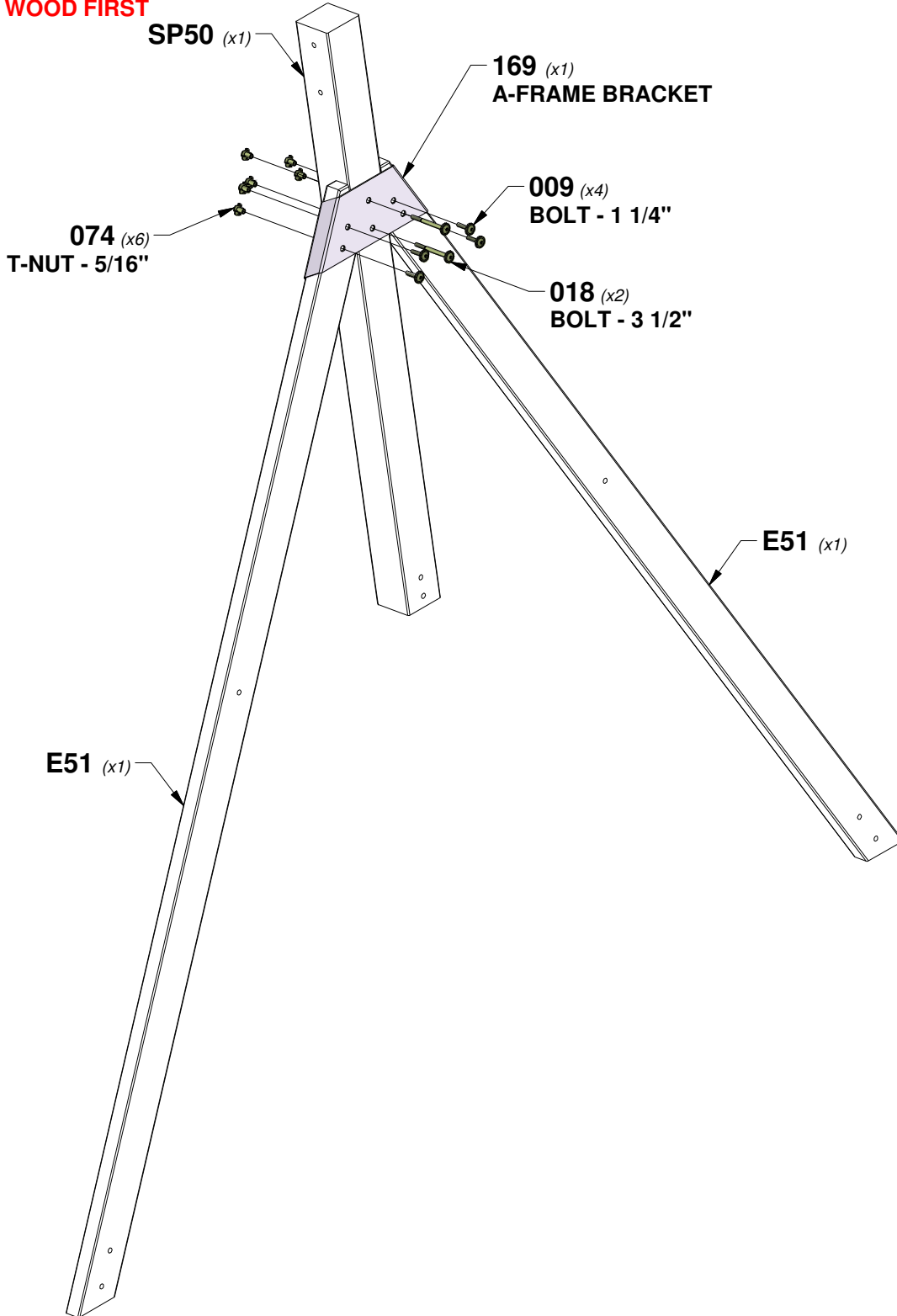

# STEP 5 - SWING BEAM

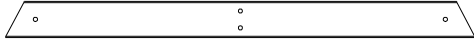

**E50** | END SUPPORT - W4L16003  
(x1) | 1 3/8"x3 3/8"x44 1/8" (36x86x1120)



**G14** | GROUND BOARD - W4L16019  
(x1) | 15/16"x5 1/4"x86 11/16" (24x134x2202)

QTY	PART NUMBER	DESCRIPTION
4	H100013	BOLT WH 5/16x2 1/4
2	H100015	BOLT WH 5/16x2 3/4
8	H100030	WASHER LOCK EXT 8x19
8	H100074	T-NUT 5/16
2	H100505	BOLT WH 5/16x4 3/4

**TIP:**  
INSTALL T-NUTS IN WOOD FIRST

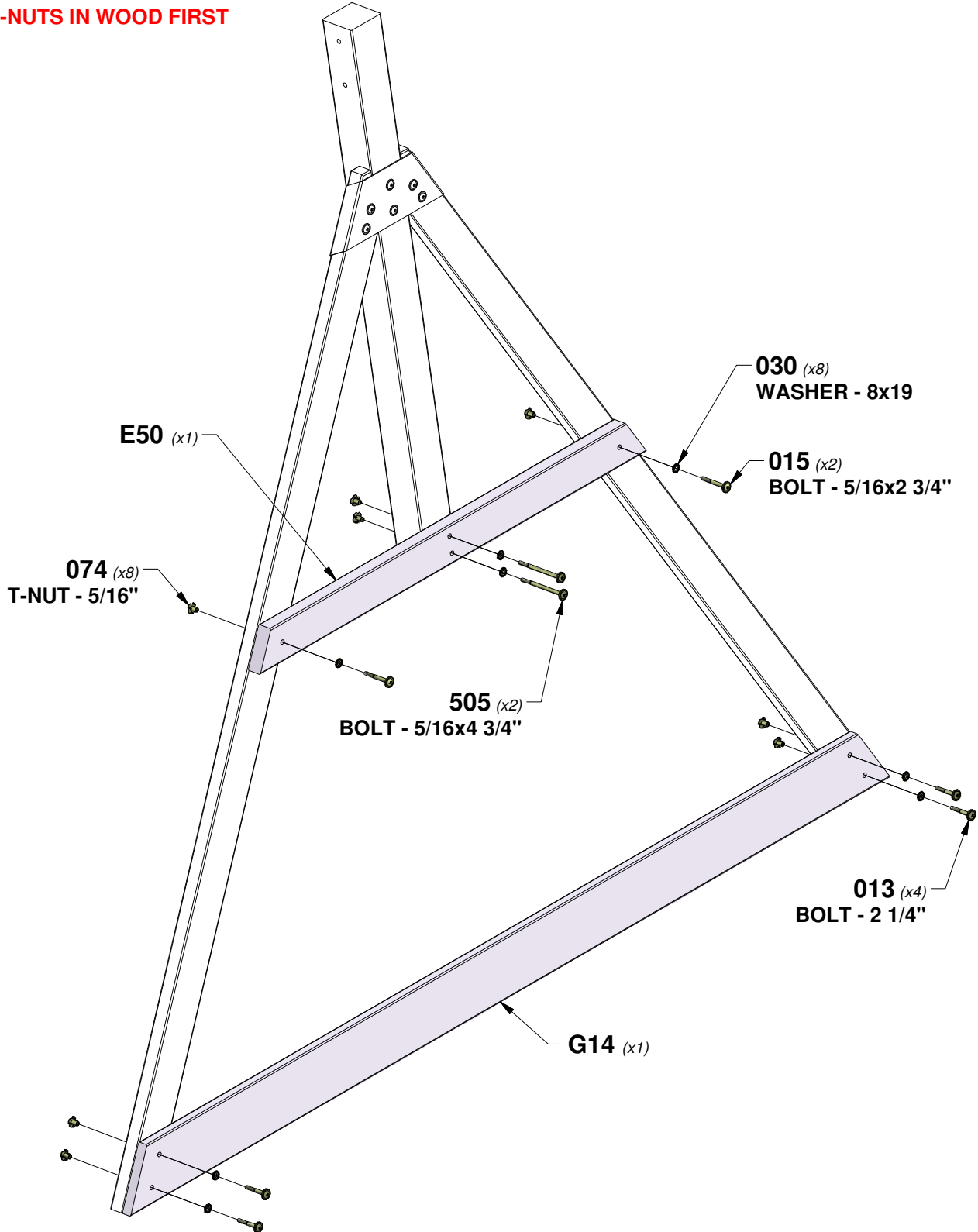

# STEP 6 - SWING BEAM

QTY	PART NUMBER	DESCRIPTION
2	H100005	NUT BARREL WH 5/16x7/8
2	H100016	BOLT WH 5/16x3

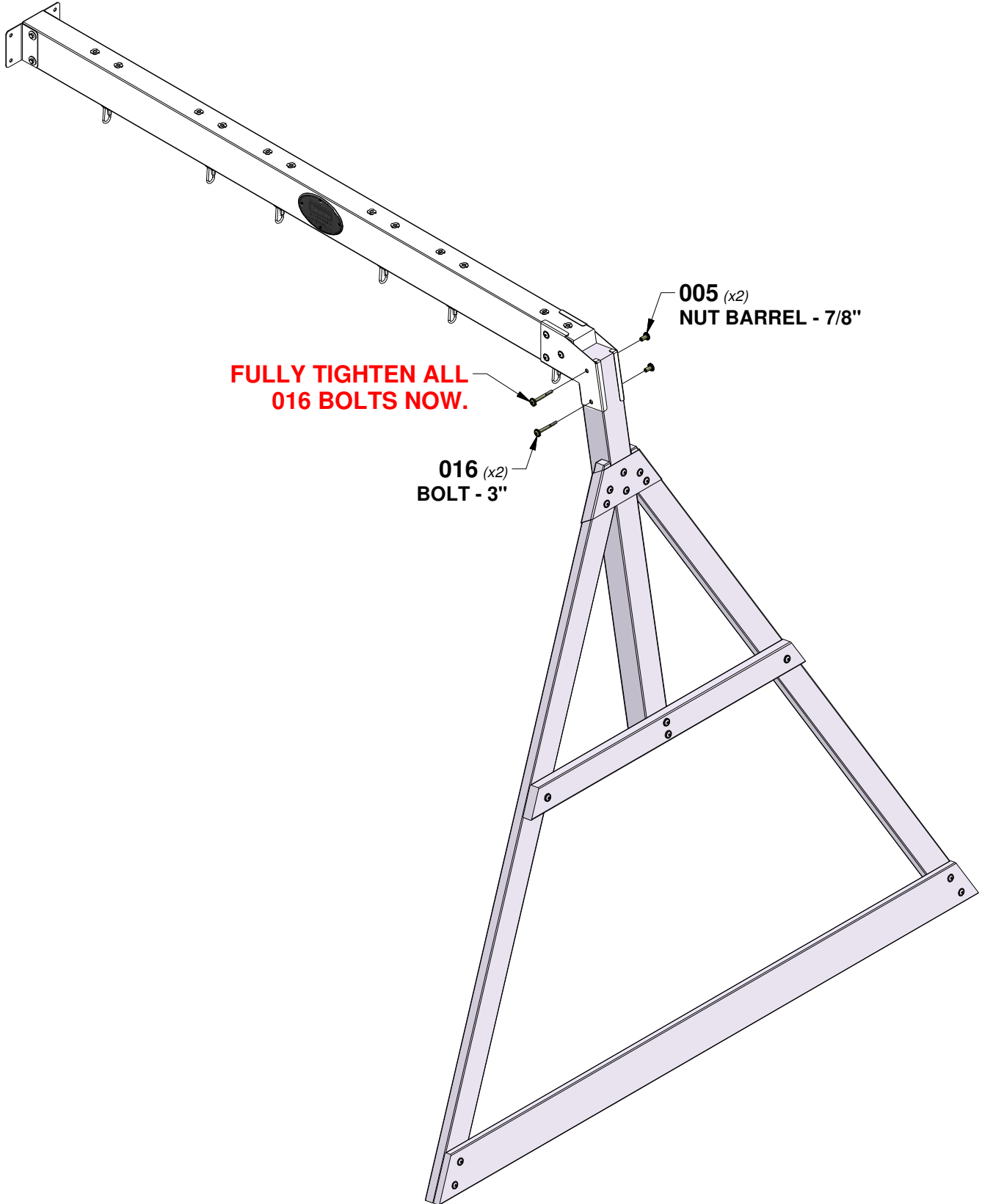

# STEP 1 - FORT ASSEMBLY

QTY	PART NUMBER	DESCRIPTION
2	H100013	BOLT WH 5/16x2 1/4
12	H100028	LAG SCREW WH 5/16x2 1/2
14	H100030	WASHER LOCK EXT 8x19
2	H100074	T-NUT 5/16
2	H100138	WASHER LOCK EXT 6x15
2	H100146	LAG SCREW WH 1/4x2

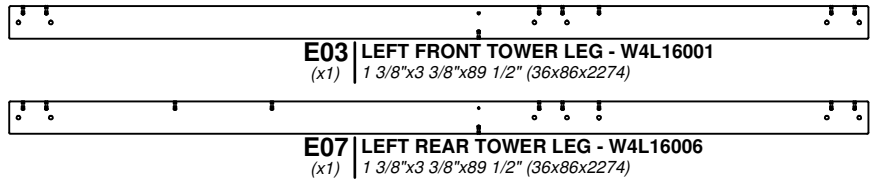
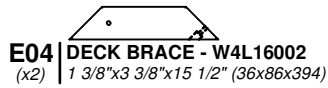
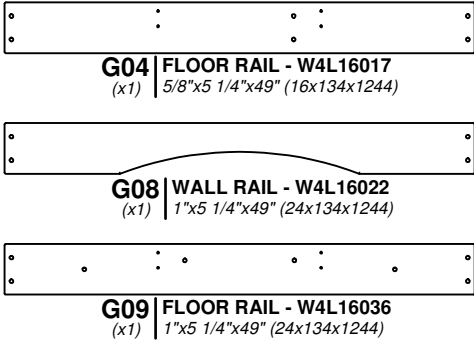

**TIP:**  
INSTALL T-NUTS IN WOOD FIRST

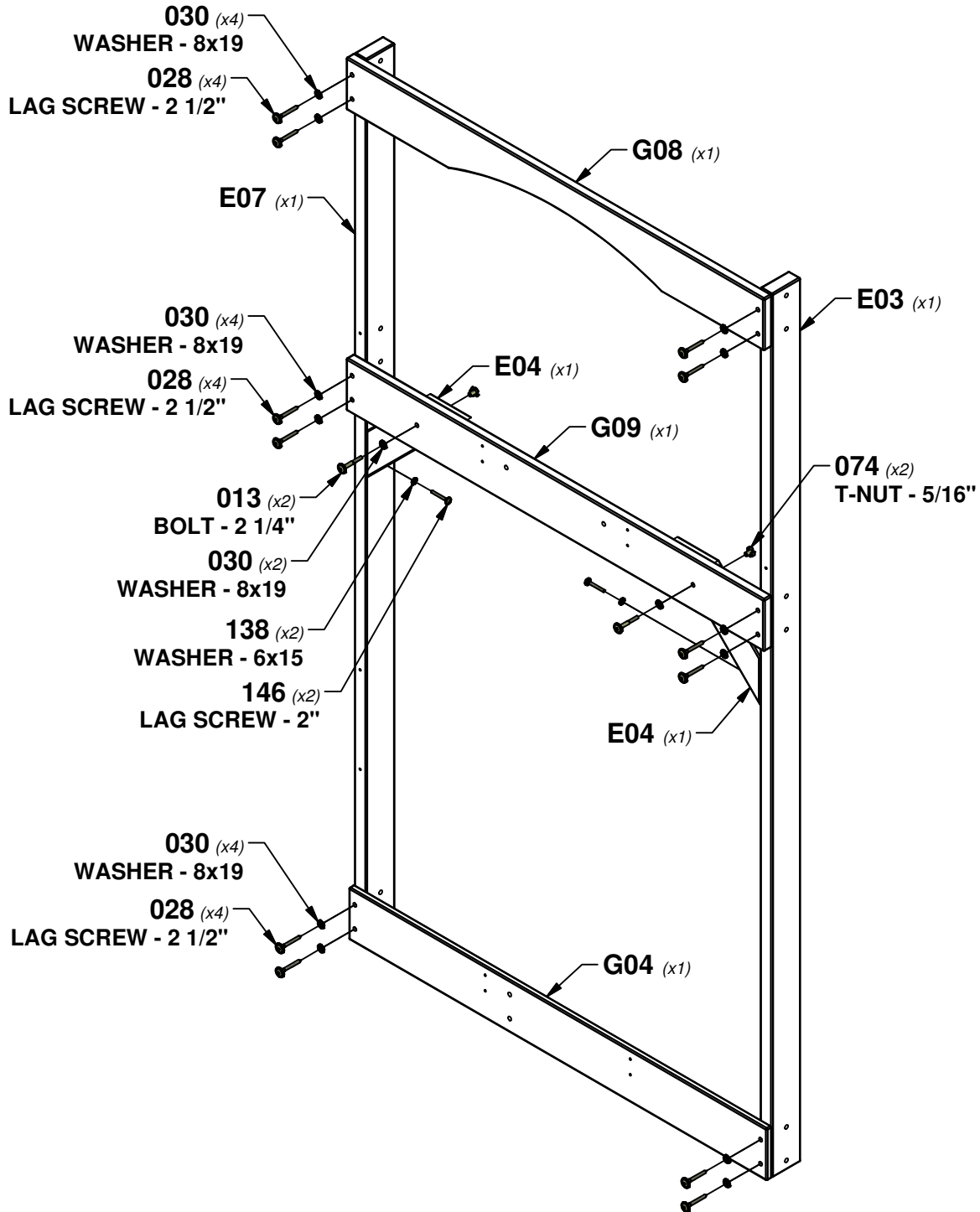

# STEP 2 - FORT ASSEMBLY

QTY	PART NUMBER	DESCRIPTION
20	H100028	LAG SCREW WH 5/16x2 1/2
20	H100030	WASHER LOCK EXT 8x19

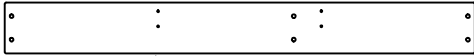

**G04** FLOOR RAIL - W4L16017  
(x1) 5/8"x5 1/4"x49" (16x134x1244)

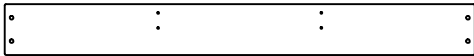

**G07** FLOOR RAIL - W4L16021  
(x2) 1"x5 1/4"x49" (24x134x1244)

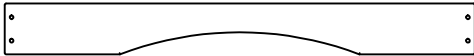

**G08** WALL RAIL - W4L16022  
(x1) 1"x5 1/4"x49" (24x134x1244)

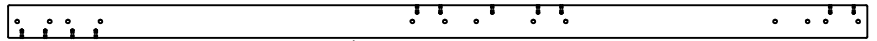

**E02** CENTER FRONT TOWER LEG - W4L16000  
(x1) 1 3/8"x3 3/8"x89 1/2" (36x86x2274)

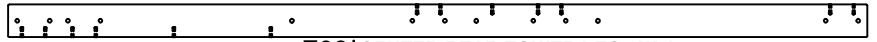

**E06** CENTER REAR TOWER LEG - W4L16005  
(x1) 1 3/8"x3 3/8"x89 1/2" (36x86x2274)

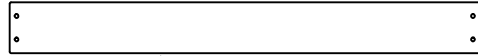

**K02** BASE/SAND BOX BOARD - W4L16035  
(x1) 5/8"x5 1/4"x49" (16x134x1244)

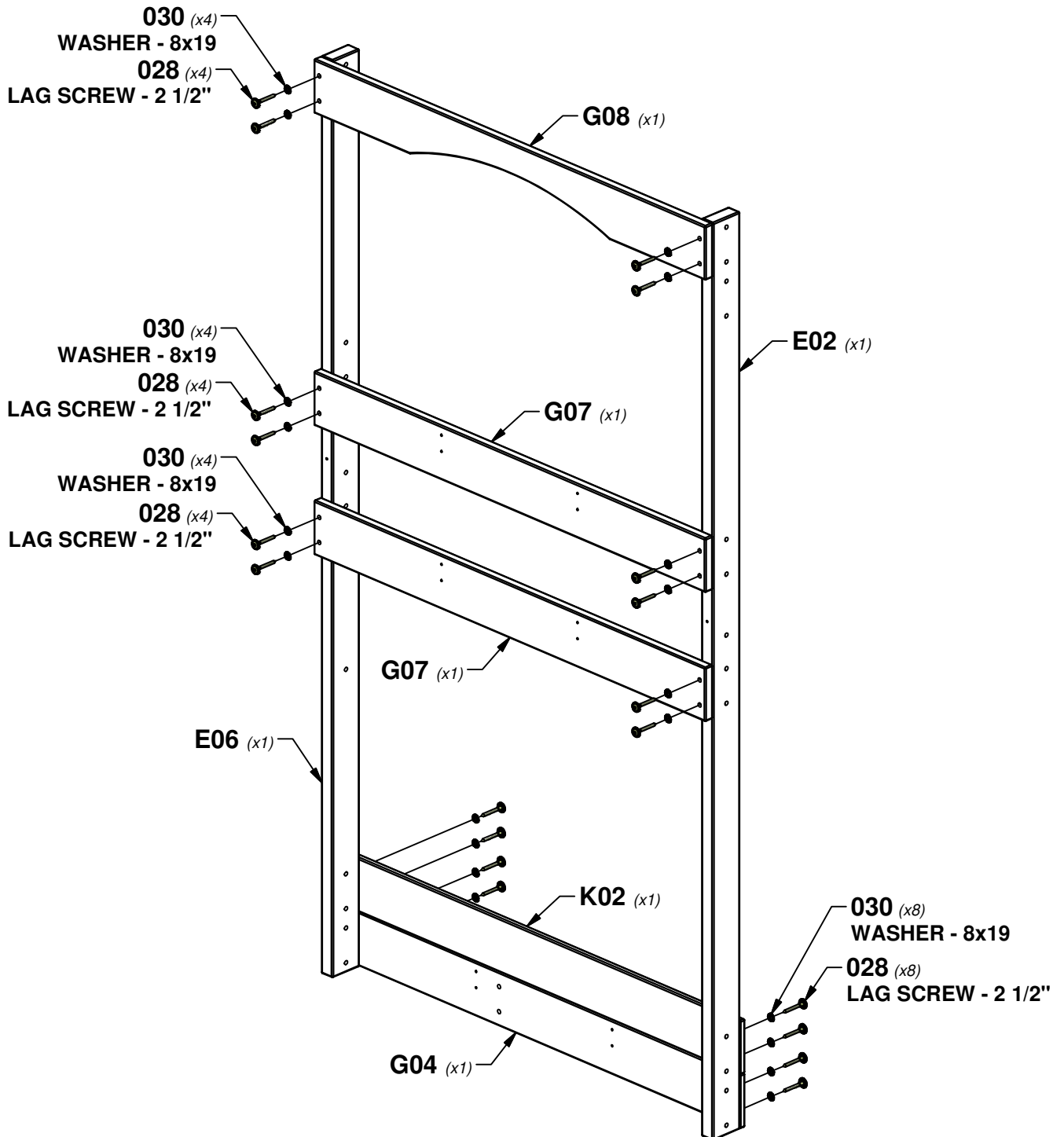

# STEP 3 - FORT ASSEMBLY

QTY	PART NUMBER	DESCRIPTION
2	H100013	BOLT WH 5/16x2 1/4
2	H100027	LAG SCREW WH 5/16x2
12	H100028	LAG SCREW WH 5/16x2 1/2
20	H100030	WASHER LOCK EXT 8x19
10	H100074	T-NUT 5/16
2	H100138	WASHER LOCK EXT 6x15
2	H100146	LAG SCREW WH 1/4x2
4	H100166	BOLT WH 5/16x4 1/4

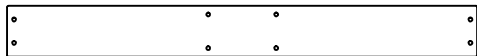

**G05** | WALL RAIL/SWING MOUNT - W4L16018  
(x1) | 1"x5 1/4"x49" (24x134x1244)

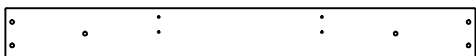

**G06** | FLOOR RAIL - W4L16020  
(x1) | 1"x5 1/4"x49" (24x134x1244)



**K02** | BASE/SAND BOX BOARD - W4L16035  
(x2) | 5/8"x5 1/4"x49" (16x134x1244)

**E04** | DECK BRACE - W4L16002  
(x2) | 1 3/8"x3 3/8"x15 1/2" (36x86x394)

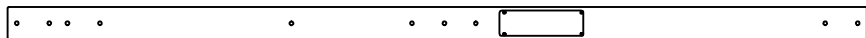

**E05** | RIGHT REAR TOWER LEG - W2A03283  
(x1) | 1 3/8"x3 3/8"x89 1/2" (36x86x2274)

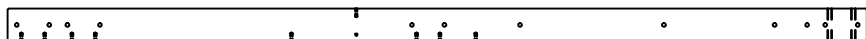

**E01** | RIGHT FRONT TOWER LEG - W4L15999  
(x1) | 1 3/8"x3 3/8"x89 1/2" (36x86x2274)

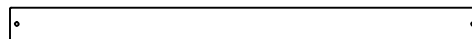

**M05** | WALL RAIL - W4L16066  
(x1) | 5/8"x3 3/8"x49" (16x86x1244)

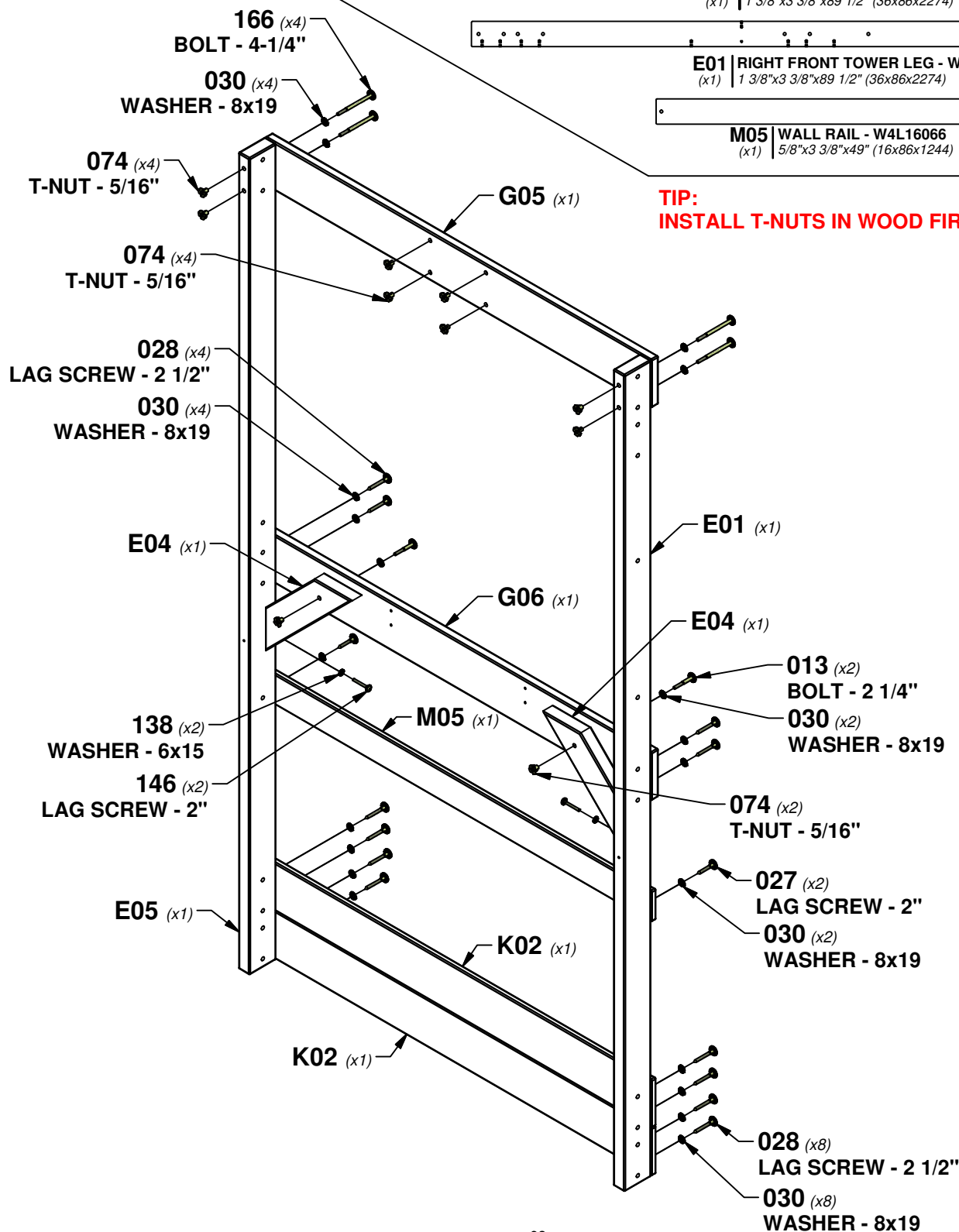

# STEP 4 - FORT ASSEMBLY

QTY	PART NUMBER	DESCRIPTION
12	H100012	BOLT WH 5/16x2
8	H100016	BOLT WH 5/16x3
20	H100030	WASHER LOCK EXT 8x19
20	H100074	T-NUT 5/16



**G01** | BASE BOARD - W4L16009  
(x2) | 5/8"x5 1/4"x82 1/4" (16x134x2088)

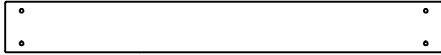

**K03** | GROUND BOARD - W4L16038  
(x2) | 5/8"x5 1/4"x45 1/2" (16x134x1156)



**H05** | BOTTOM FLOOR BOARD SUPPORT - W4L16024  
(x4) | 1"x3 3/8"x5 1/4" (24x86x134)

**TIP:**  
INSTALL T-NUTS IN WOOD FIRST

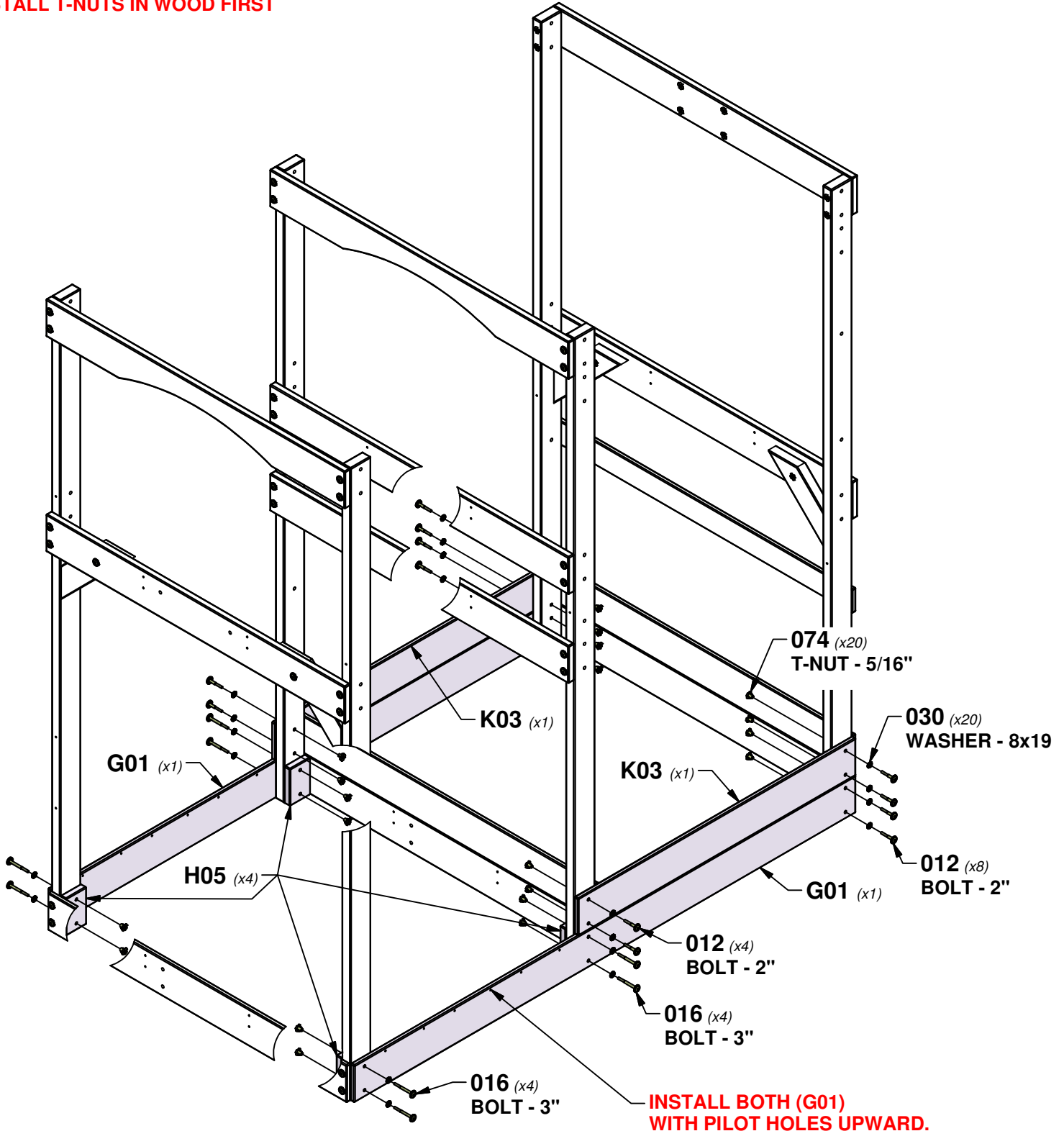

# STEP 5 - FORT ASSEMBLY

QTY	PART NUMBER	DESCRIPTION
4	H100013	BOLT WH 5/16x2 1/4
12	H100017	BOLT WH 5/16x3 1/4
16	H100030	WASHER LOCK EXT 8x19
16	H100074	T-NUT 5/16

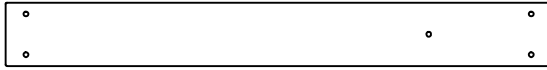

**G10** | FLOOR RAIL - W4L16010  
(x1) | 1"x5 1/4"x45 1/2" (24x134x1156)

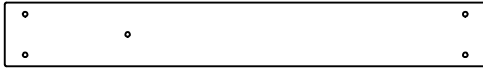

**G12** | FLOOR RAIL - W4L16012  
(x2) | 1"x5 1/4"x40 1/8" (24x134x1018)



**H05** | BOTTOM FLOOR BOARD SUPPORT - W4L16024  
(x6) | 1"x3 3/8"x5 1/4" (24x86x134)

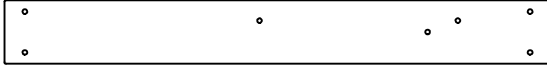

**G15** | FLOOR RAIL - W4L16014  
(x1) | 1"x5 1/4"x45 1/2" (24x134x1156)

**TIP:**  
**INSTALL T-NUTS IN WOOD FIRST**

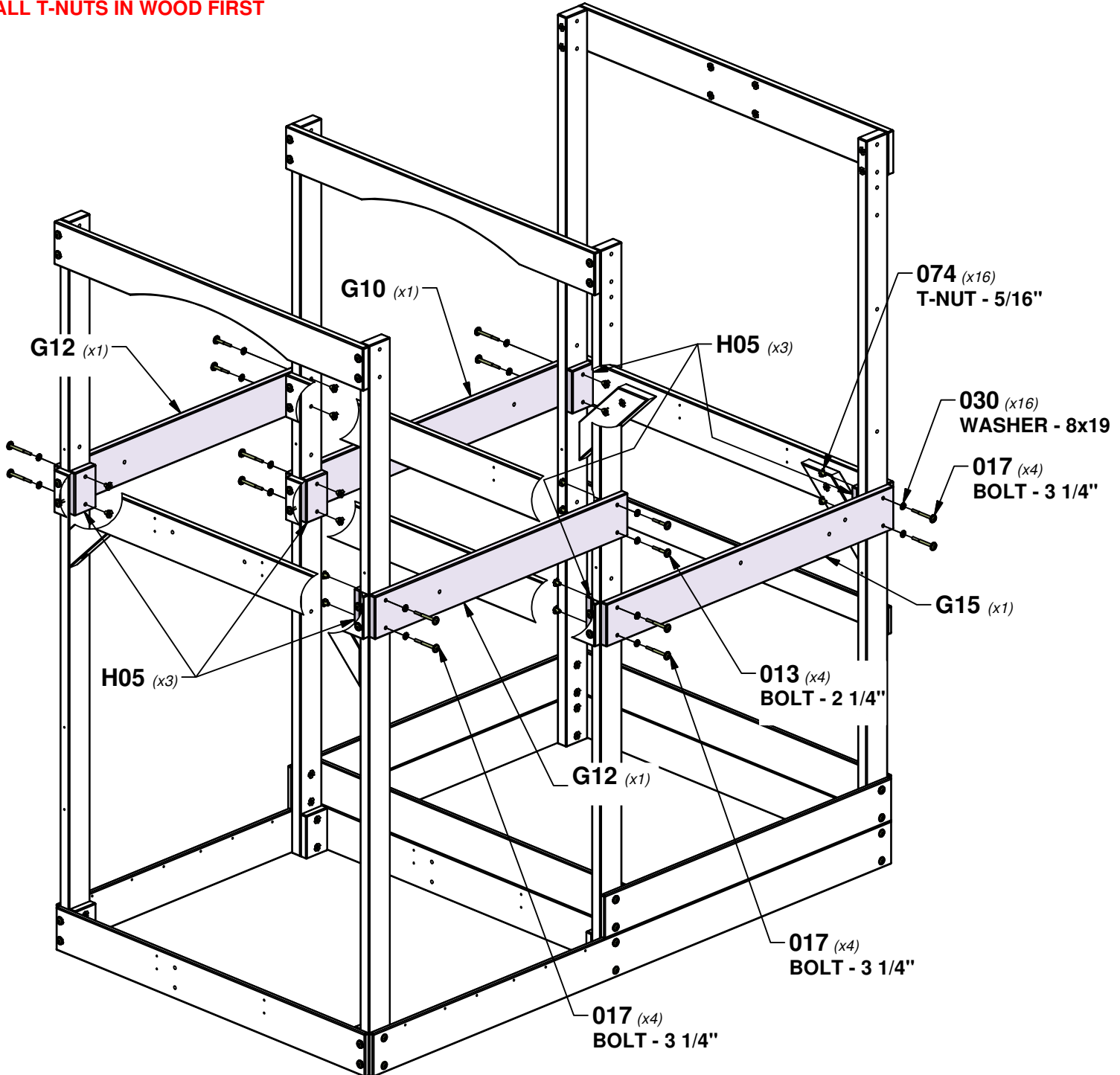



# STEP 6 - FORT ASSEMBLY

QTY	PART NUMBER	DESCRIPTION
12	H100013	BOLT WH 5/16x2 1/4
16	H100030	WASHER LOCK EXT 8x19
16	H100074	T-NUT 5/16
4	H100012	BOLT WH 5/16x2

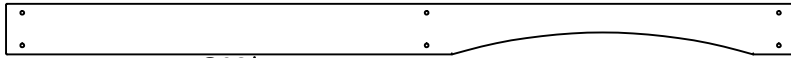

**G02** | WALL RAIL - W4L16015  
(x1) | 1"x5 1/4"x82 1/4" (24x134x2088)

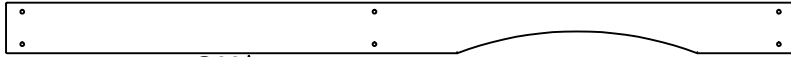

**G03** | WALL RAIL - W4L16016  
(x1) | 1"x5 1/4"x82 1/4" (24x134x2088)

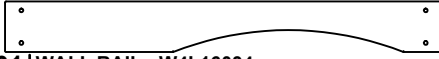

**K01** | WALL RAIL - W4L16034  
(x1) | 5/8"x5 1/4"x45 1/2" (16x134x1156)

**TIP:**  
INSTALL T-NUTS IN WOOD FIRST

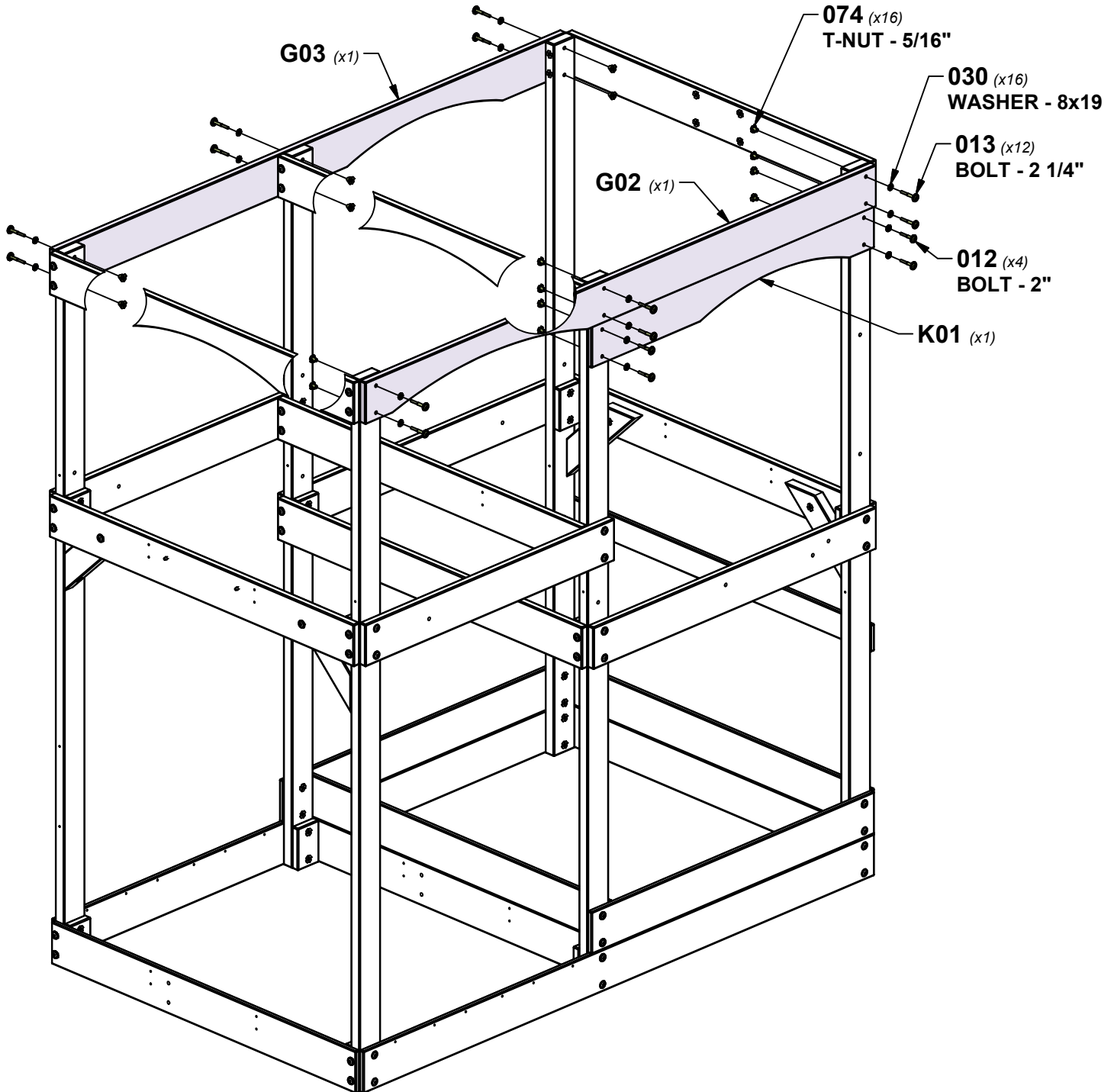

# STEP 7 - FORT ASSEMBLY

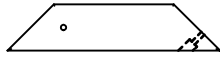

**E04** | DECK BRACE - W4L16002  
(x4) | 1 3/8"x3 3/8"x15 1/2" (36x86x394)

QTY	PART NUMBER	DESCRIPTION
4	H100013	BOLT WH 5/16x2 1/4
4	H100030	WASHER LOCK EXT 8x19
4	H100074	T-NUT 5/16
4	H100138	WASHER LOCK EXT 6x15
4	H100146	LAG SCREW WH 1/4x2

**TIP:**  
INSTALL T-NUTS IN WOOD FIRST

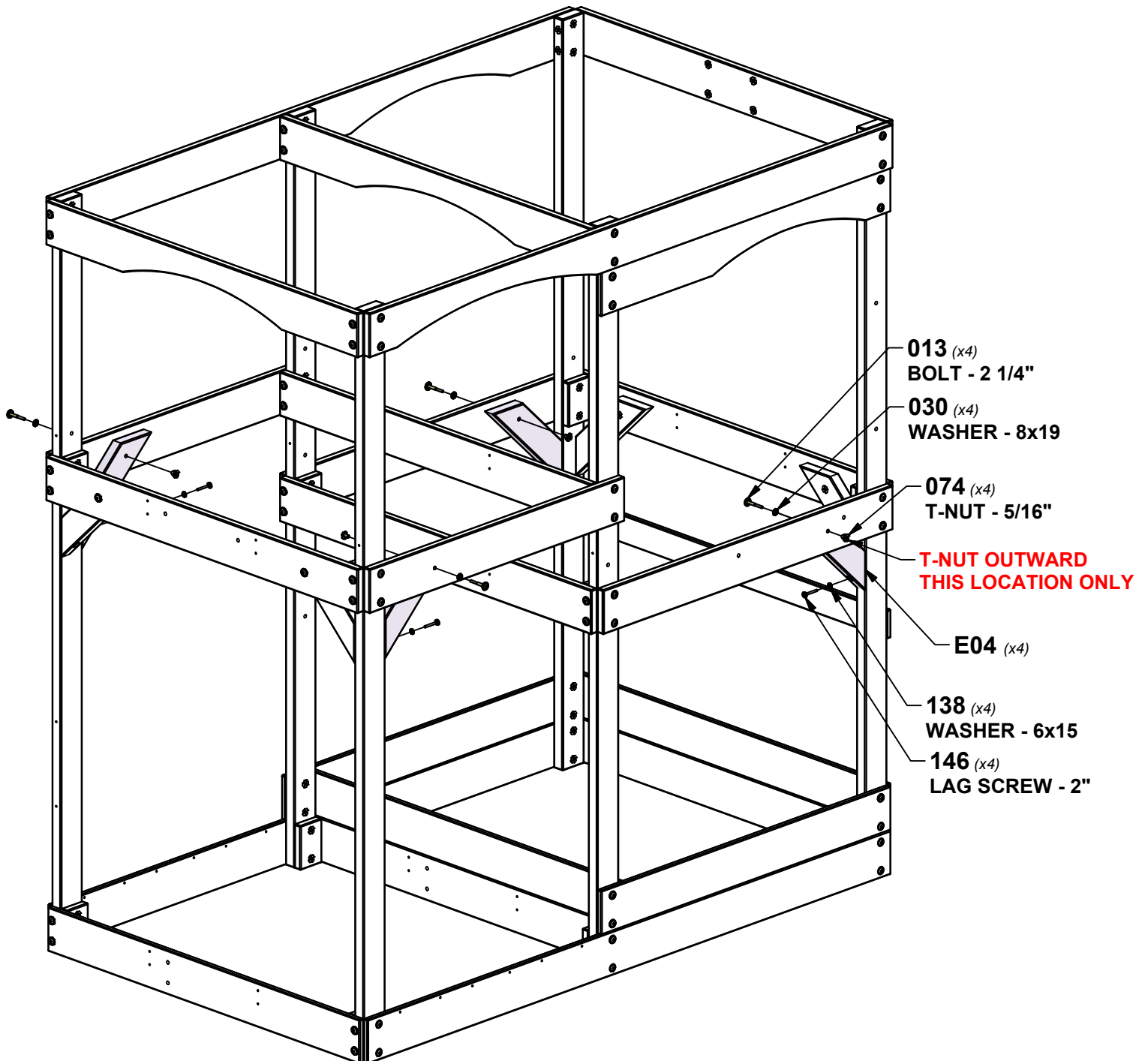

# STEP 8 - FORT ASSEMBLY

QTY	PART NUMBER	DESCRIPTION
24	H100090	SCREW PFH 8x2 1/2
2	H100128	SCREW PWH 8x5/8

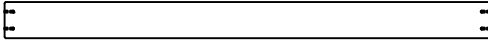

**H01** | FLOOR JOIST - W4L16023  
(x2) | 1"x3 3/8"x45 1/2" (24x86x1156)

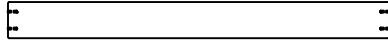

**H09** | FLOOR JOIST - W4L16032  
(x2) | 1"x3 3/8"x35 3/4" (24x86x908)

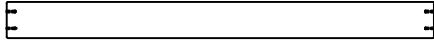

**H03** | FLOOR JOIST - W4L16026  
(x2) | 1"x3 3/8"x40 1/8" (24x86x1018)



**A100314** | "A" REVISION TAG  
(x1)

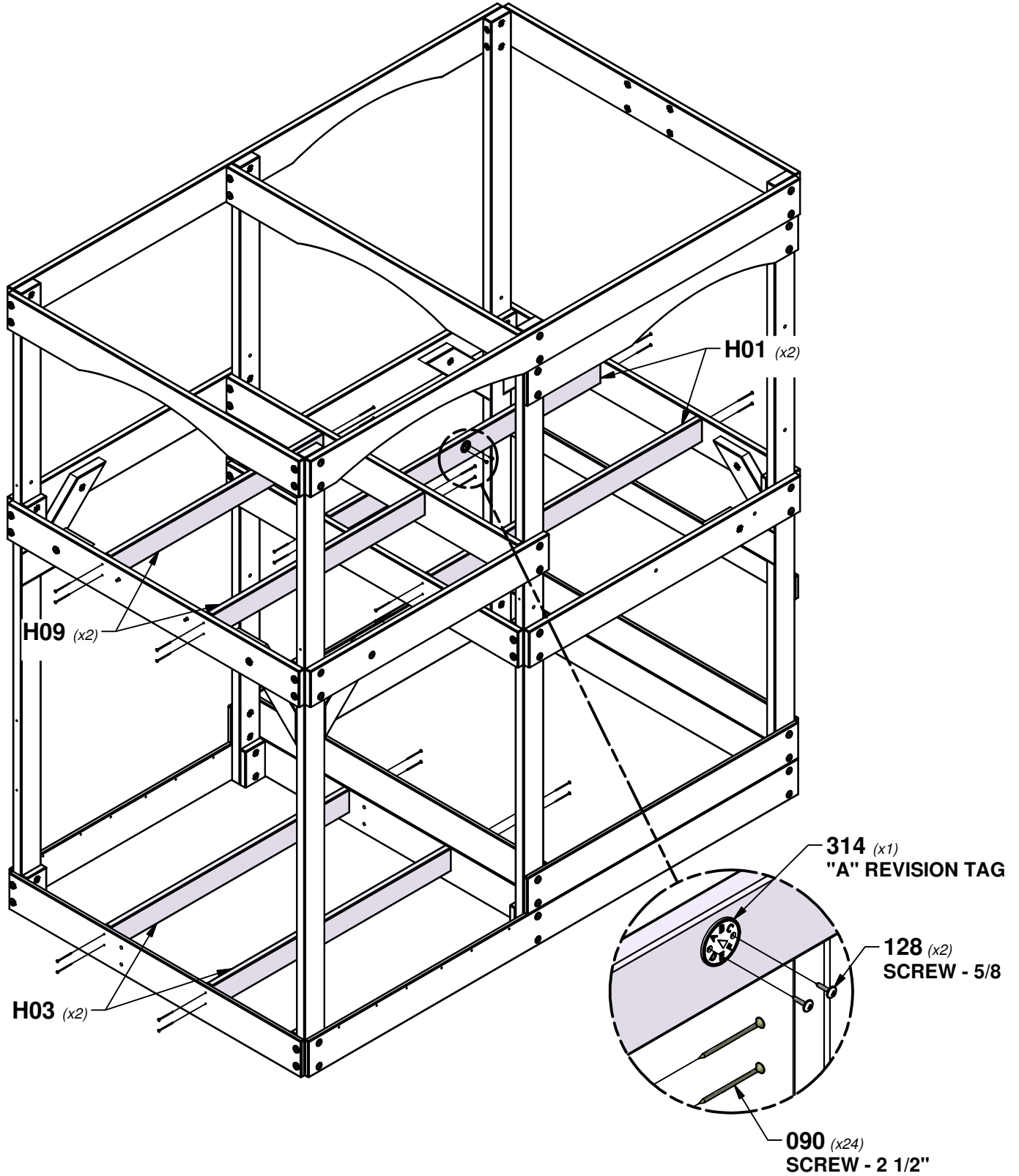

# STEP 9 - FORT ASSEMBLY



**H04** SEAT UPRIGHT - W4L16027  
(x2) 1"x3 3/8"x19" (24x86x482)

QTY	PART NUMBER	DESCRIPTION
4	H100010	BOLT WH 5/16x1 1/2
4	H100030	WASHER LOCK EXT 8x19
4	H100074	T-NUT 5/16

**TIP:**  
INSTALL T-NUTS IN WOOD FIRST

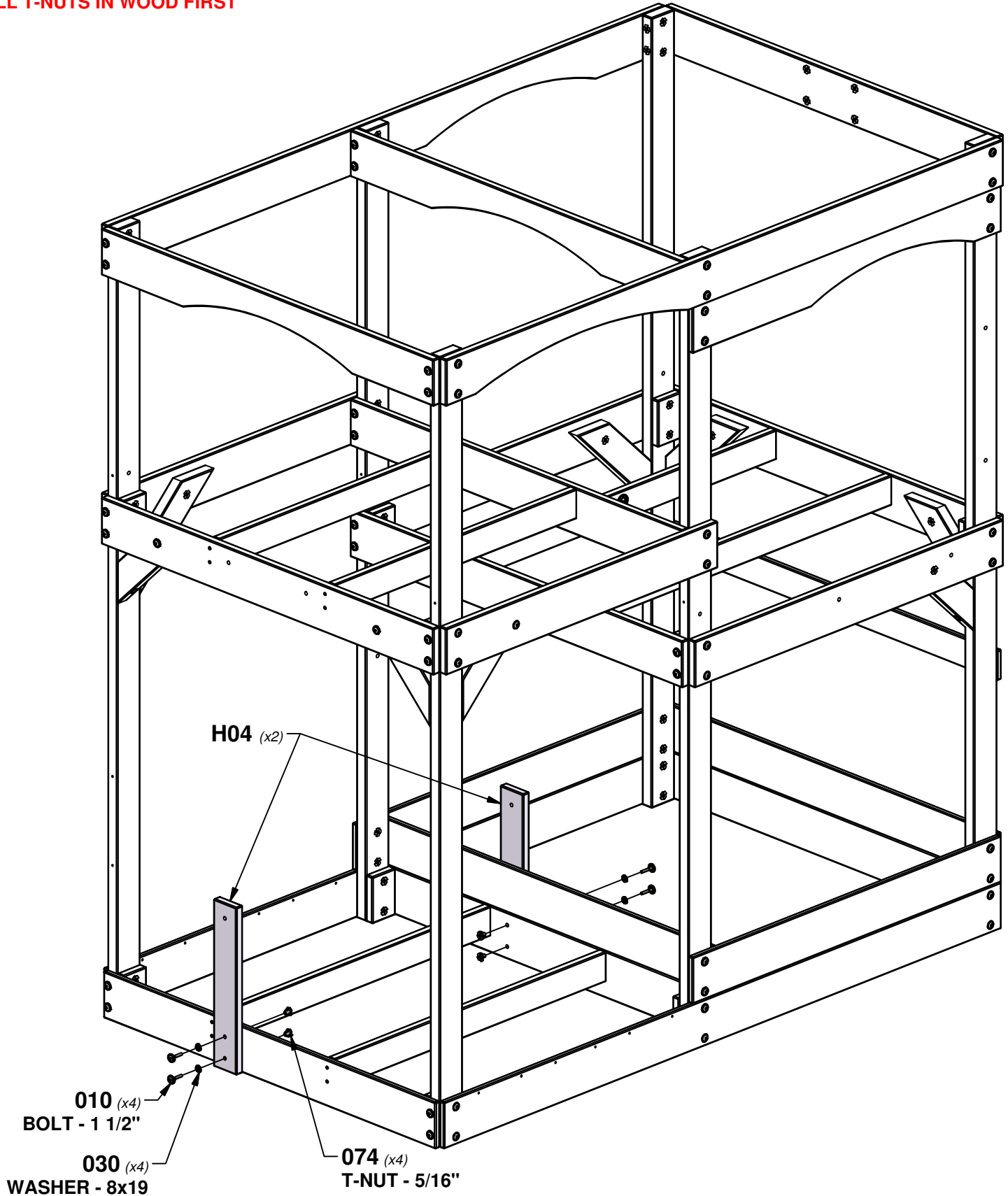

# STEP 10 - FORT ASSEMBLY

QTY	PART NUMBER	DESCRIPTION
26	H100086	SCREW PFH 8x1-1/2"
12	H100089	SCREW PFH 8x1-3/4"

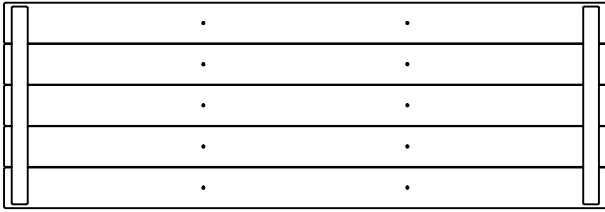

**FP1** | FLOOR PANEL - W2A03281  
(x1) | 1 5/8"x17 1/8"x50 1/4" (40x434x1276)



**FP2** | FLOOR PANEL - W2A03282  
(x1) | 1 5/8"x16 1/8"x50 1/4" (40x408x1276)



**M02** | FLOOR BOARD - W4L16055  
(x1) | 5/8"x3 3/8"x46" (16x86x1168)

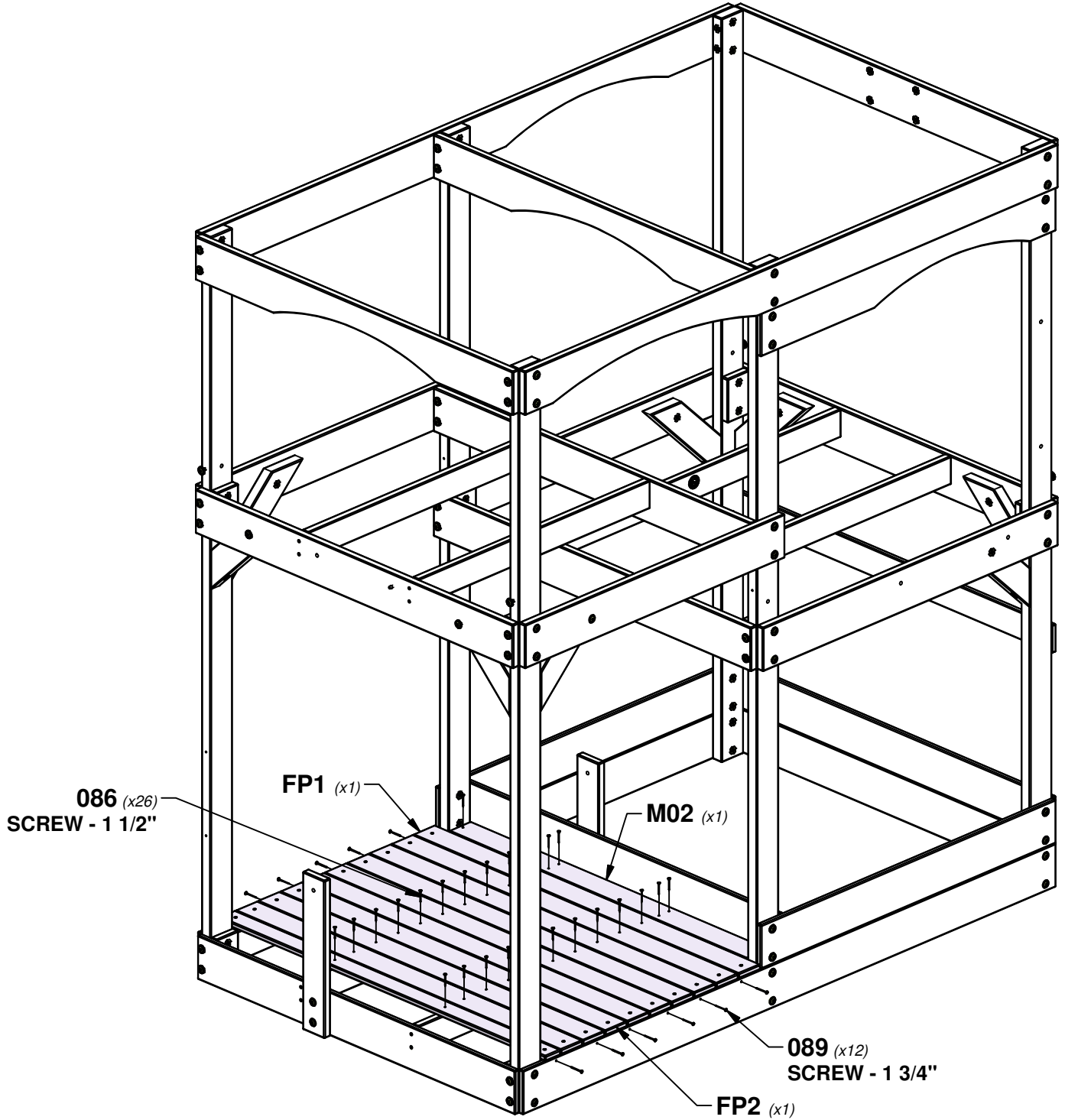

# STEP 11 - FORT ASSEMBLY

QTY	PART NUMBER	DESCRIPTION
78	H100086	SCREW PFH 8x1-1/2"

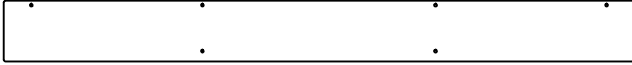

**L01** | OUTSIDE FILLER FLOOR BOARD - W4L16039  
(x2) | 5/8"x4 3/8"x46" (16x112x1168)

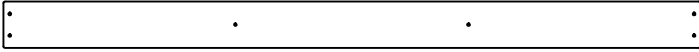

**M03** | FLOOR BOARD - W4L16063  
(x11) | 5/8"x3 3/8"x50 7/8" (16x86x1292)

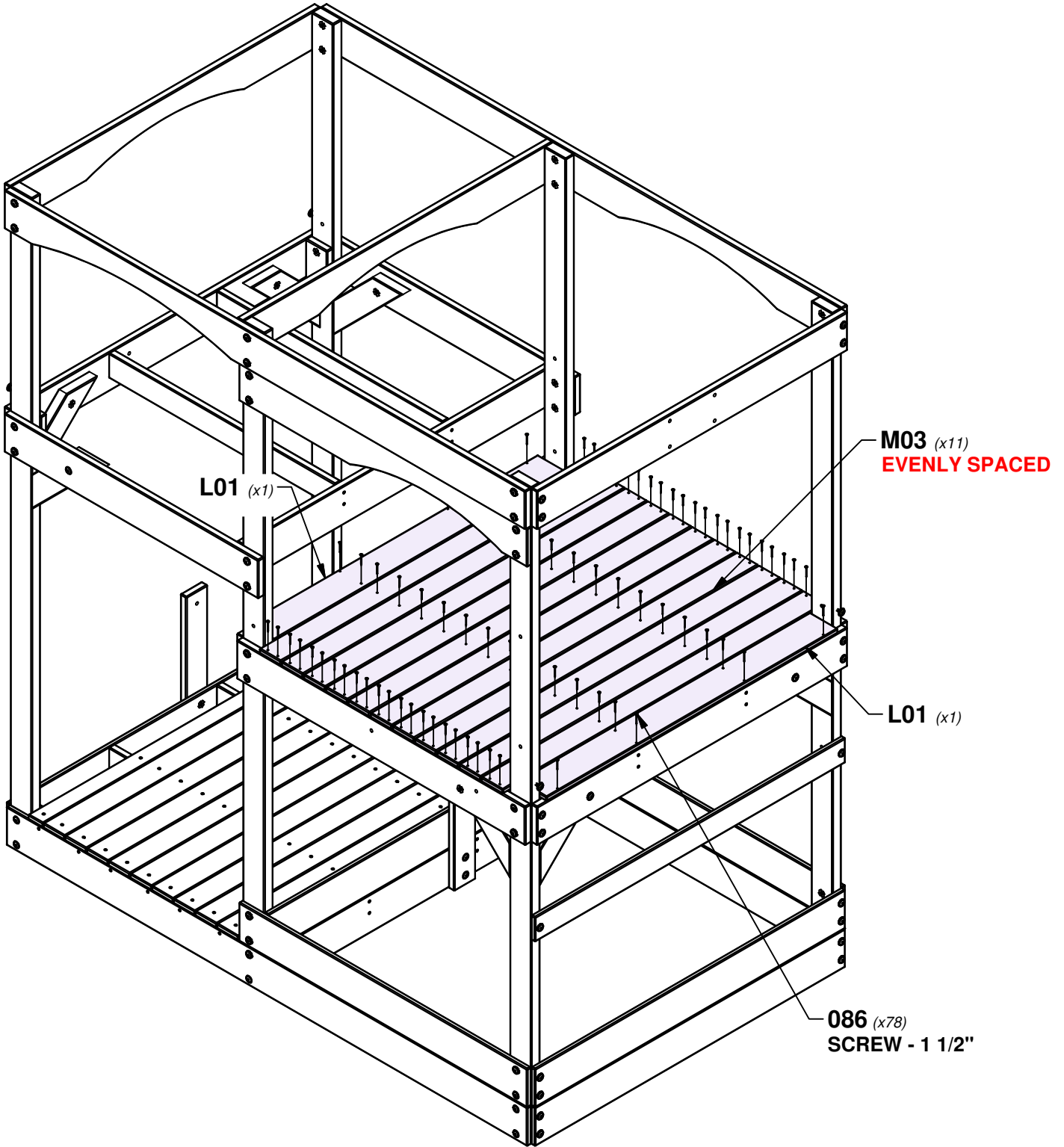

# STEP 12 - FORT ASSEMBLY

QTY	PART NUMBER	DESCRIPTION
2	H100011	BOLT WH 5/16x1 3/4
2	H100030	WASHER LOCK EXT 8x19
2	H100074	T-NUT 5/16

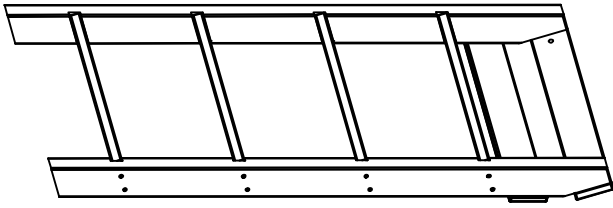

LADDER ASSEMBLY

**TIP:**  
INSTALL T-NUTS IN WOOD FIRST

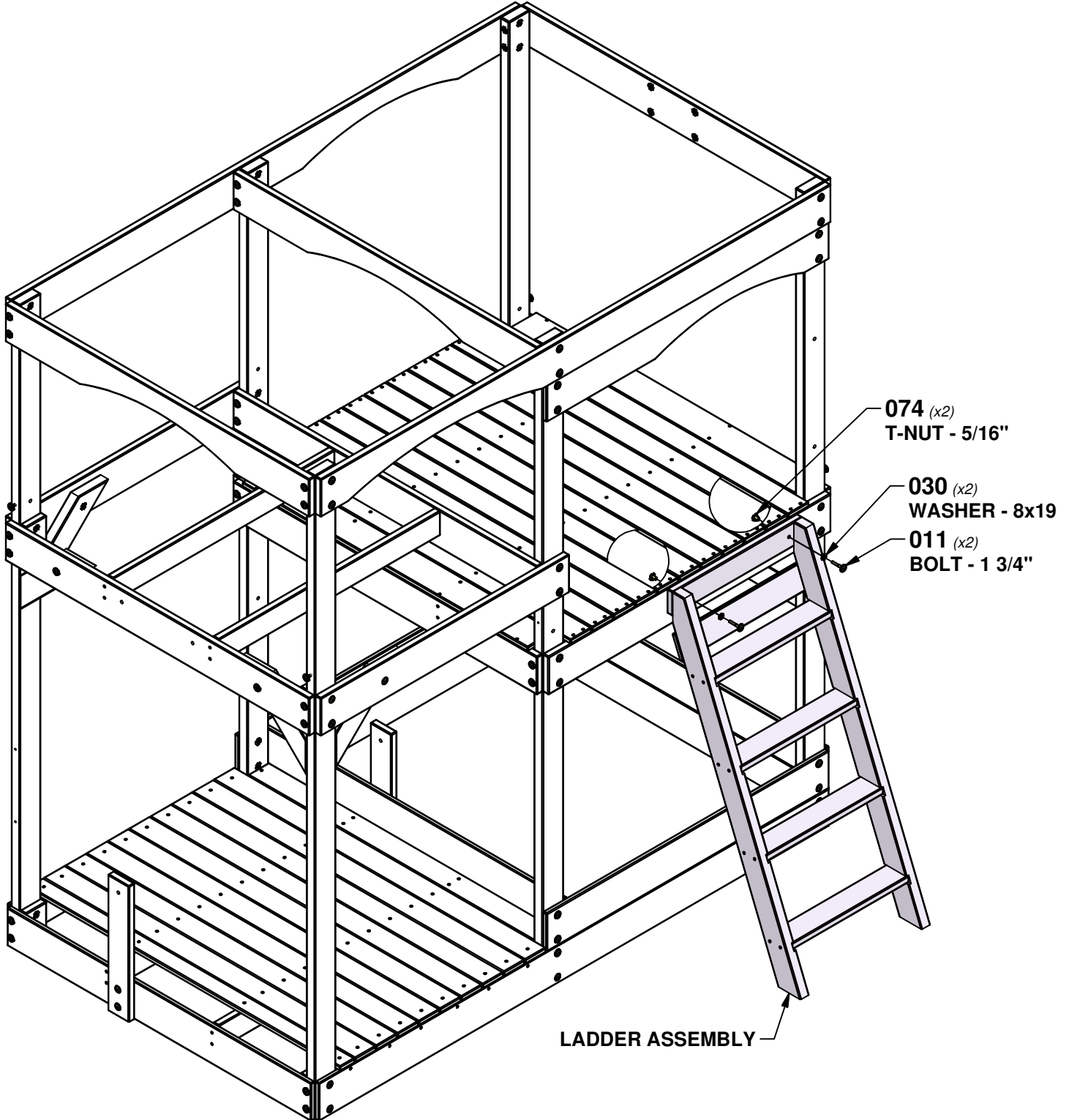

LADDER ASSEMBLY



# STEP 13 - FORT ASSEMBLY

QTY	PART NUMBER	DESCRIPTION
64	H100086	SCREW PFH 8x1-1/2"



**M03** | FLOOR BOARD - W4L16063  
(x9) 5/8"x3 3/8"x50 7/8" (16x86x1292)

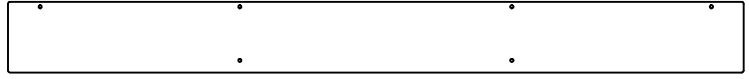

**L01** | OUTSIDE FILLER FLOOR BOARD - W4L16039  
(x1) 5/8"x4 3/8"x46" (16x112x1168)

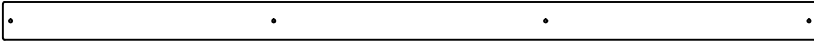

**N01** | FLOOR BOARD - W4L16076  
(x1) 5/8"x2 3/8"x50 7/8" (16x60x1292)

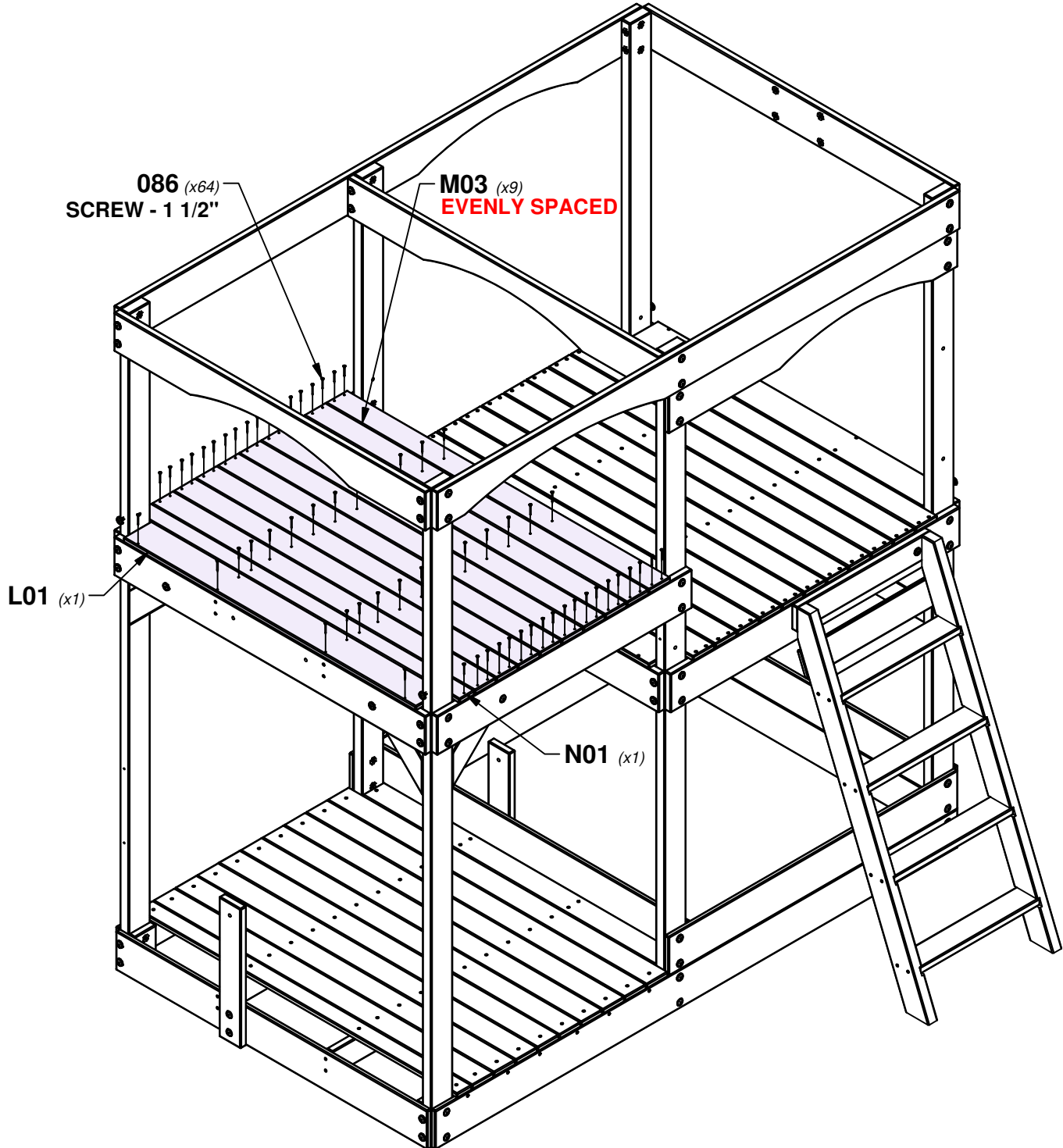



# STEP 14 - FORT ASSEMBLY

QTY	PART NUMBER	DESCRIPTION
6	H100012	BOLT WH 5/16x2
6	H100030	WASHER LOCK EXT 8x19
6	H100074	T-NUT 5/16



**M06** | WALL RAIL - W4L16067  
(x2) | 5/8"x3 3/8"x45 1/2" (16x86x1156)

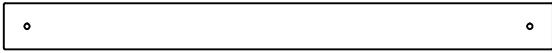

**M11** | WALL RAIL - W4L16047  
(x1) | 5/8"x3 3/8"x40 1/8" (16x86x1018)

**TIP:**  
INSTALL T-NUTS IN WOOD FIRST

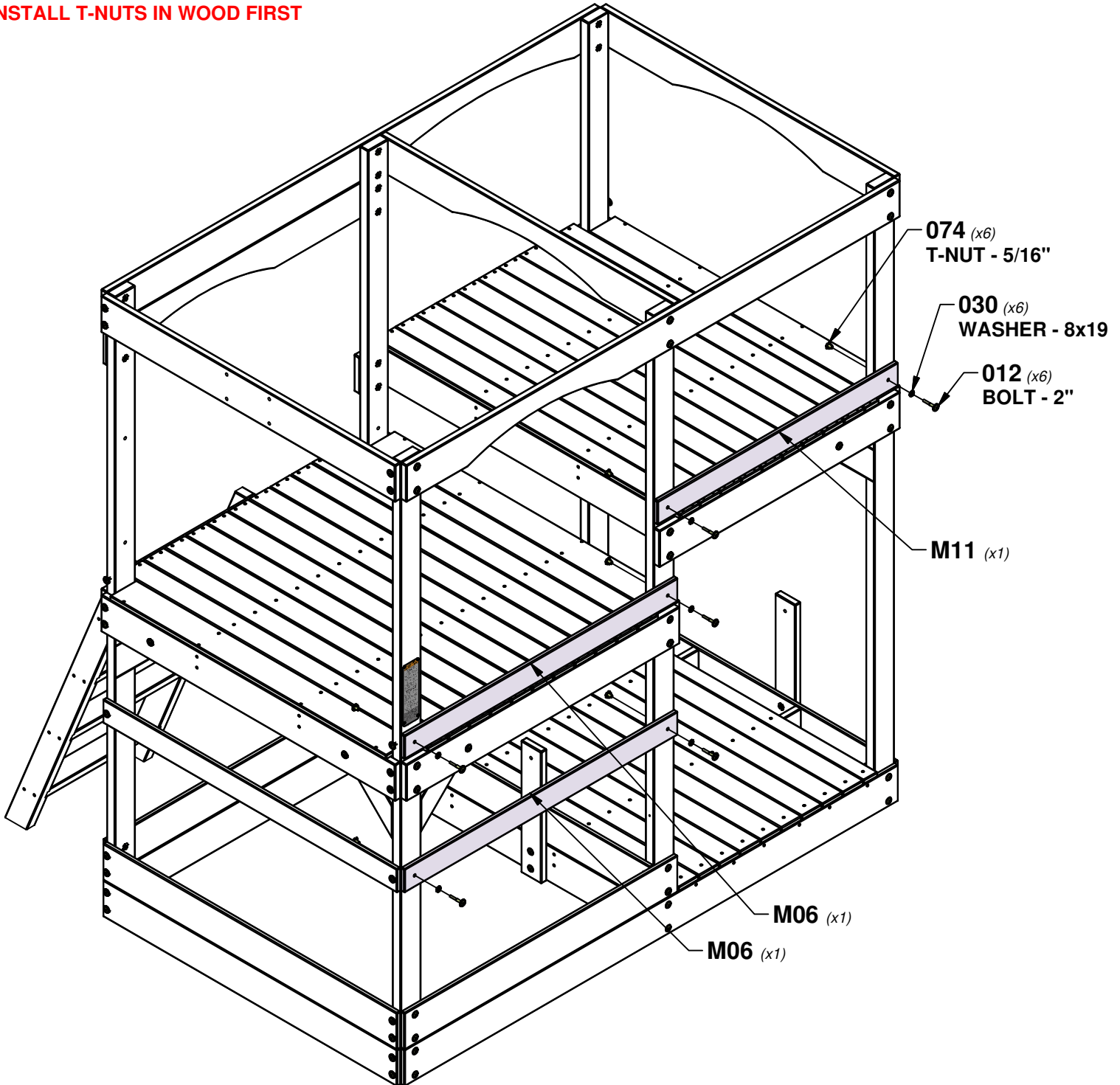

# STEP 15 - FORT ASSEMBLY

QTY	PART NUMBER	DESCRIPTION
1	H100012	BOLT WH 5/16x2
2	H100027	LAG SCREW WH 5/16x2
3	H100030	WASHER LOCK EXT 8x19
1	H100074	T-NUT 5/16



**M05** | WALL RAIL - W4L16066  
(x1) | 5/8"x3 3/8"x49" (16x86x1244)



**M18** | WALL RAIL - W4L16053  
(x1) | 5/8"x3 3/8"x16 7/8" (16x86x430)

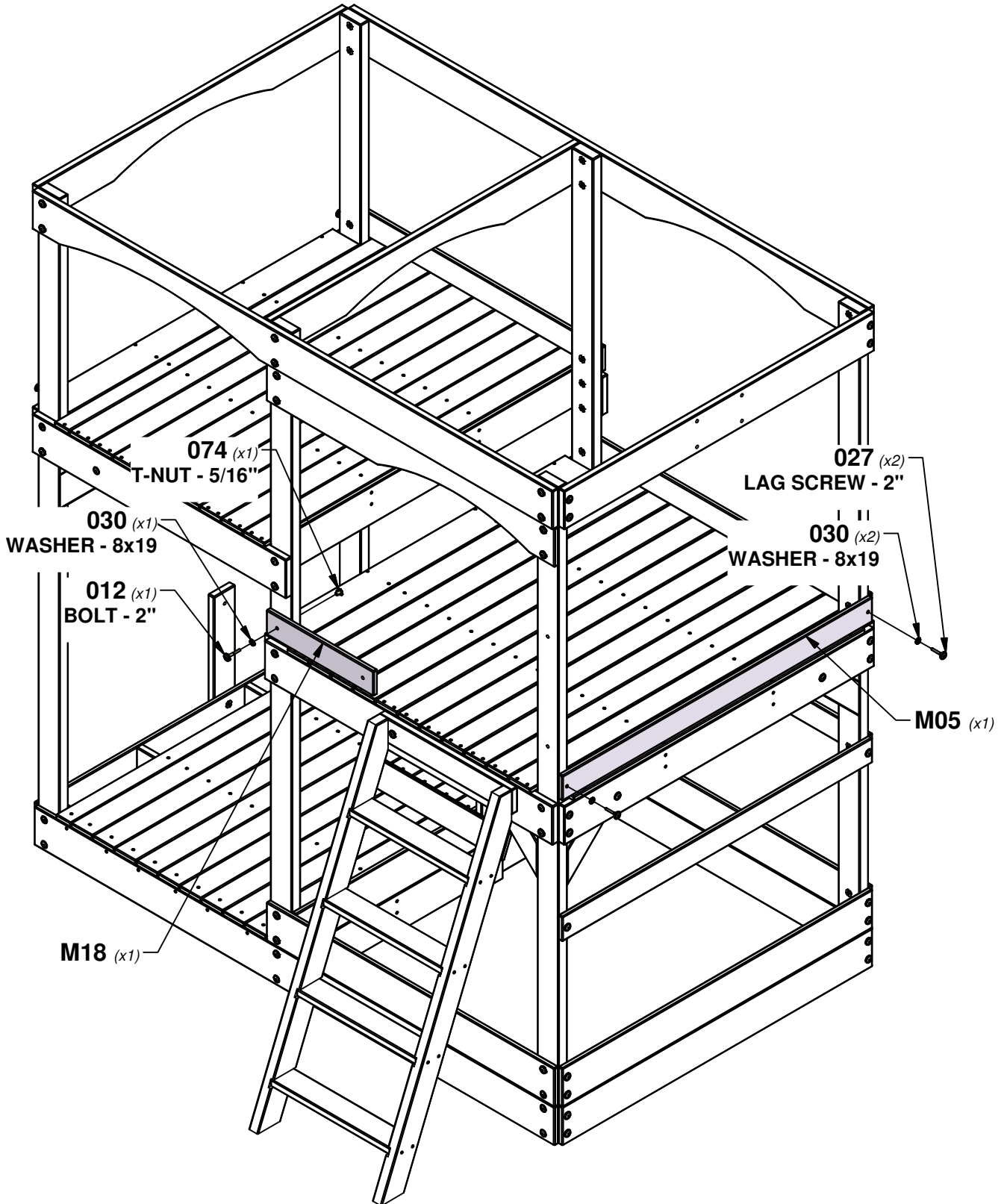

# STEP 16 - FORT ASSEMBLY

QTY	PART NUMBER	DESCRIPTION
2	H100027	LAG SCREW WH 5/16x2
2	H100028	LAG SCREW WH 5/16x2 1/2
4	H100030	WASHER LOCK EXT 8x19

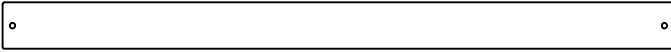

**M05** | WALL RAIL - W4L16066  
(x1) | 5/8"x3 3/8"x49" (16x86x1244)

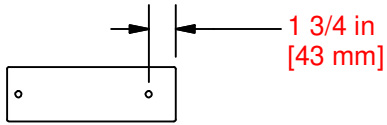

**M21** | WALL RAIL - W4L16057  
(x2) | 5/8"x3 3/8"x10 1/2" (16x86x268)

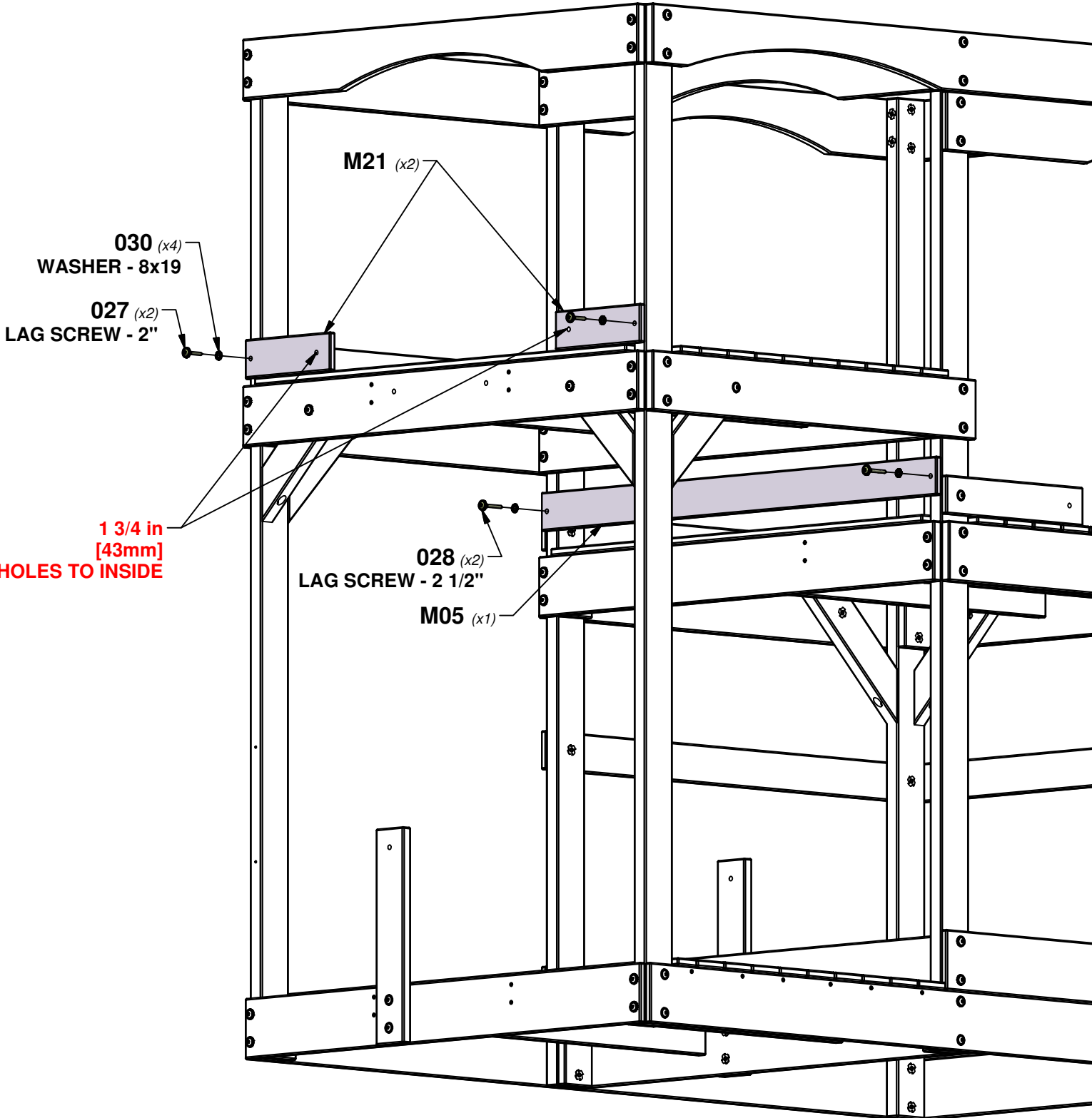

# STEP 17 - FORT ASSEMBLY

QTY	PART NUMBER	DESCRIPTION
24	H100088	SCREW PFH 8x1-1/8"



**M09** | WALL BOARD - W4L16075  
 (x6) | 5/8"x3 3/8"x32" (16x86x812)

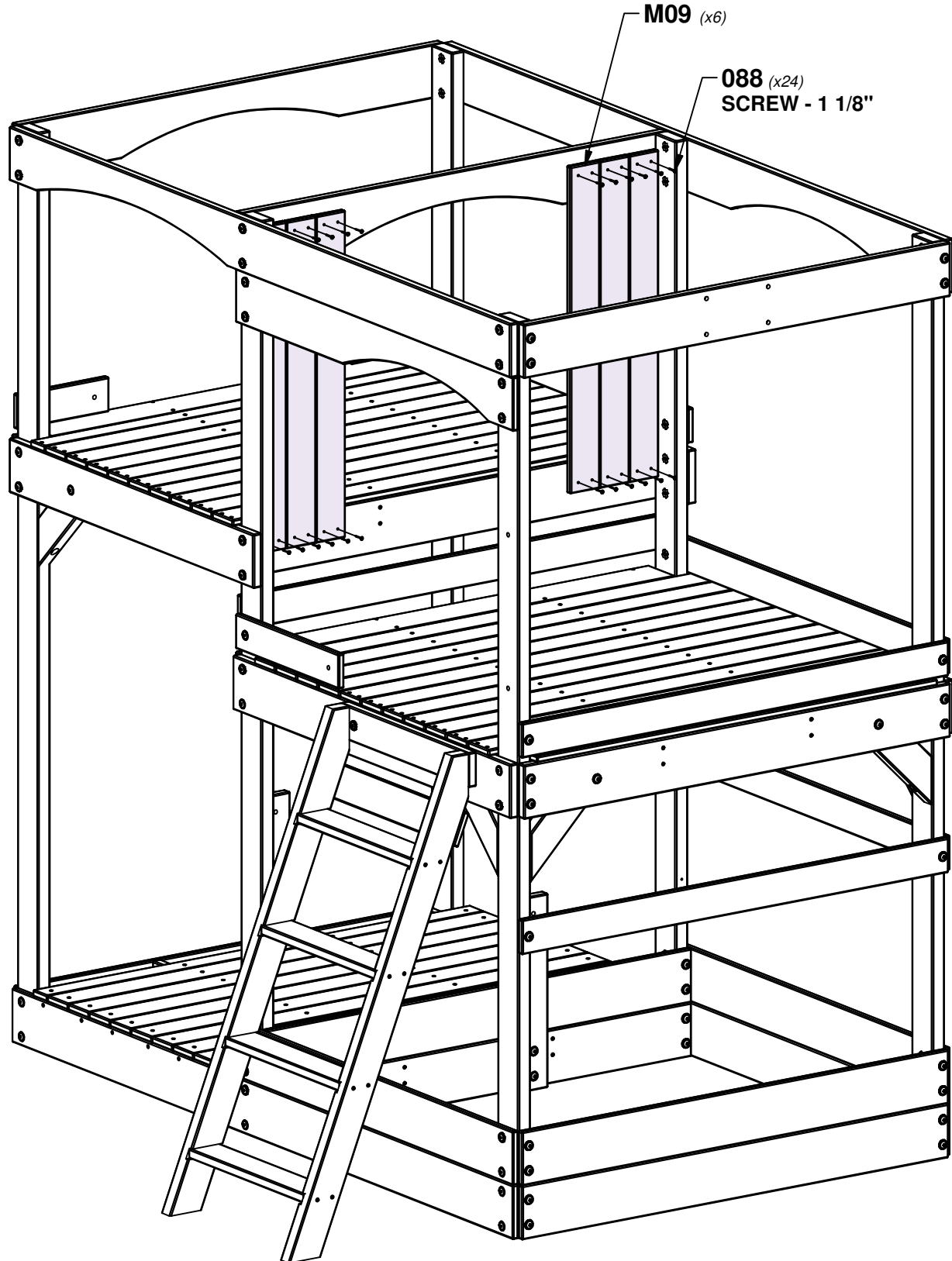
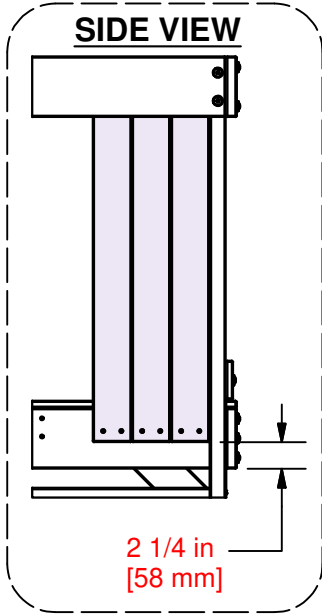

# STEP 18 - FORT ASSEMBLY



**M24** WALL BOARD - W4L16061  
(x2) 5/8"x3 3/8"x29 5/8" (16x86x752)

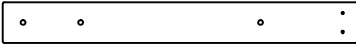

**M26** WALL BOARD - W4L16091  
(x2) 5/8"x3 3/8"x29 5/8" (16x86x752)



**A4M01046** L BRACKET  
(x2) 2.5x38x55x55

**TOP**

QTY	PART NUMBER	DESCRIPTION
2	H100005	NUT BARREL WH 5/16x7/8
2	H100008	BOLT WH 5/16x1
2	H100031	WASHER LOCK EXT 12x19
2	H100074	T-NUT 5/16
12	H100088	SCREW PFH 8x1-1/8"
2	H100115	BOLT WH 5/16x1/2

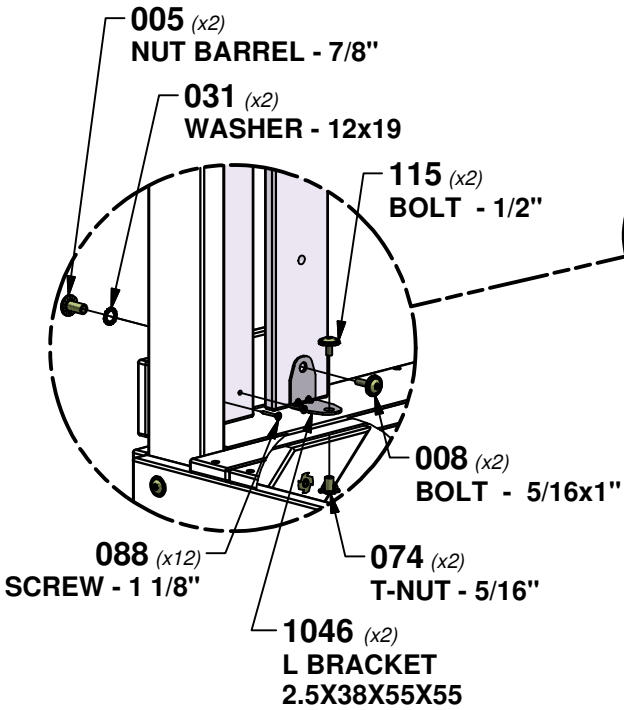
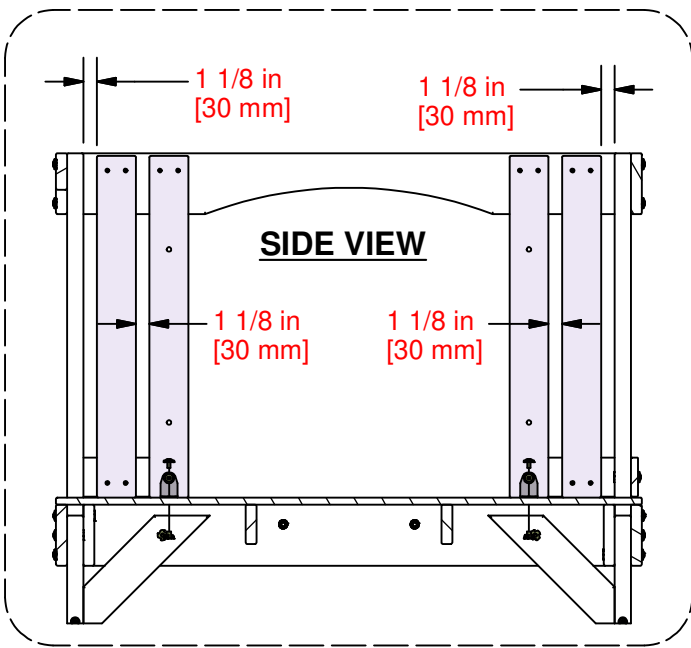

**USING L BRACKET AS A GUIDE, DRILL (2) 3/8 in [10 mm] HOLES THRU FLOOR FOR HARDWARE**

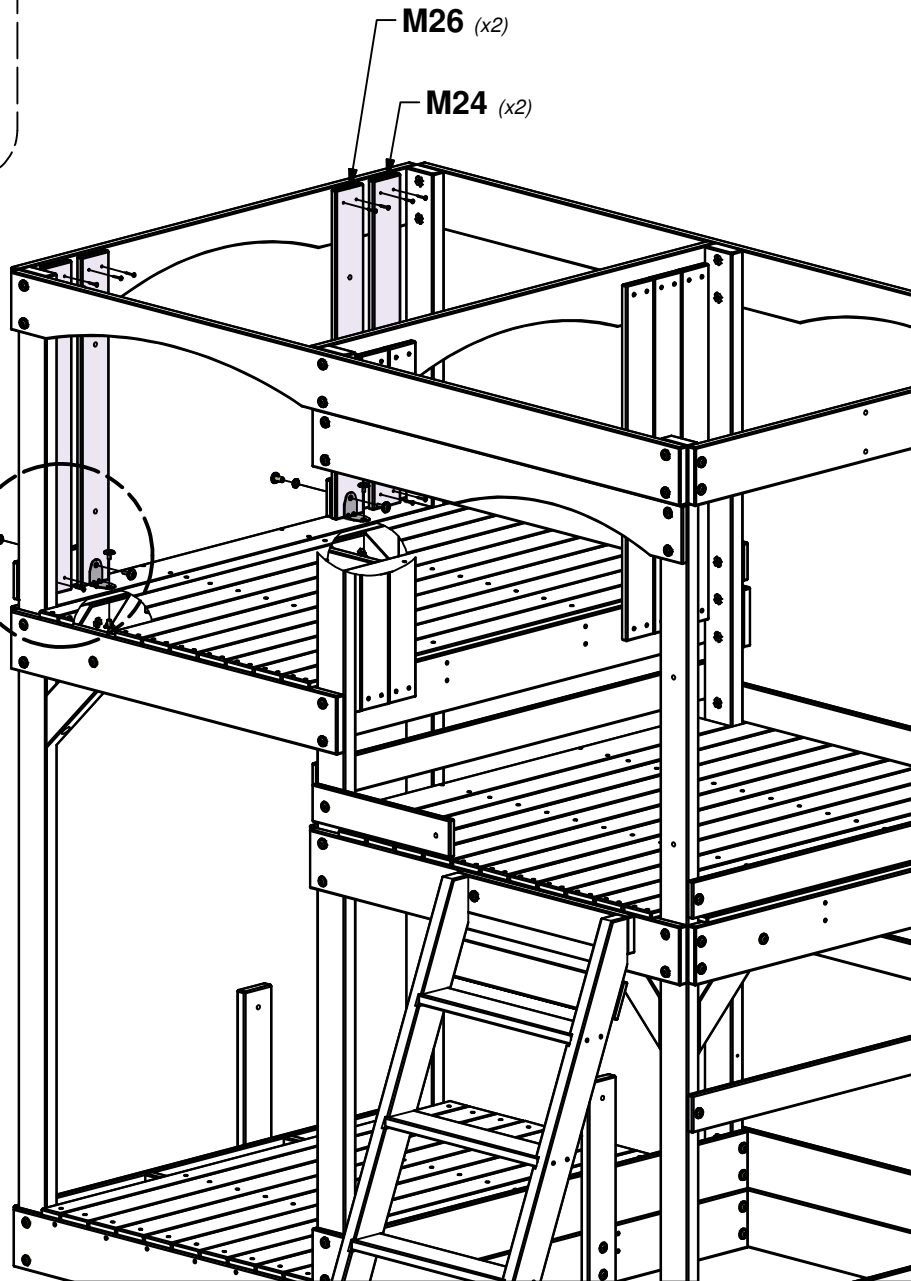

# STEP 19 - FORT ASSEMBLY

QTY	PART NUMBER	DESCRIPTION
20	H100088	SCREW PFH 8x1-1/8"



**M24** | WALL BOARD - W4L16061  
(x5) 5/8"x3 3/8"x29 5/8" (16x86x752)

## SIDE VIEW

2 3/4 in TYPICAL SPACING  
[69 mm]

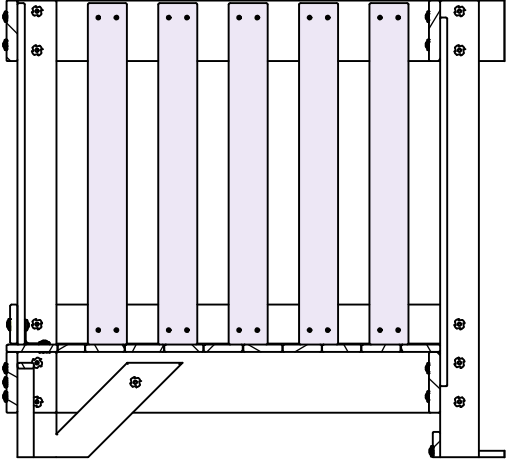

USE A6P00410 PICKET PAL FOR SPACING

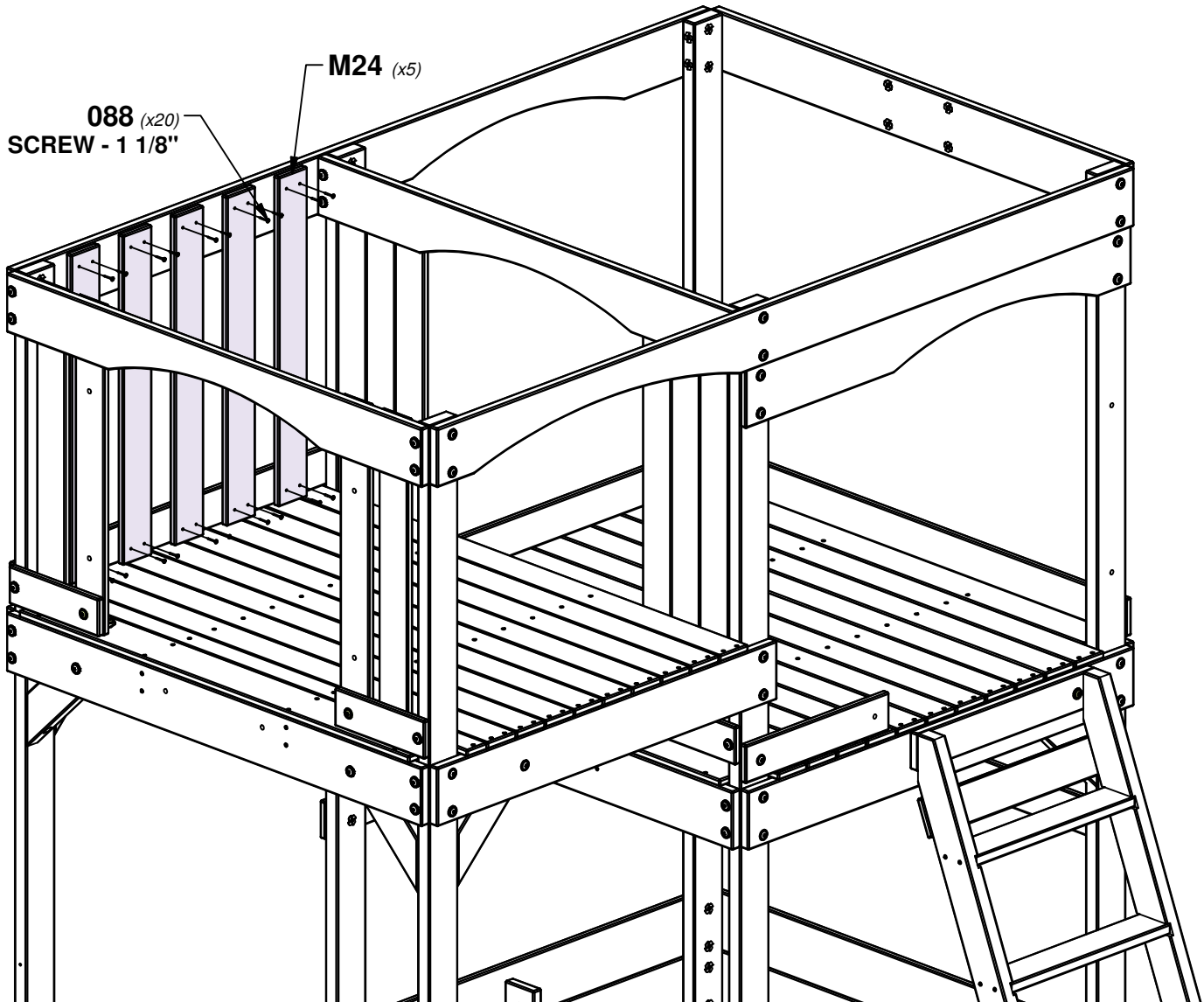

# STEP 20 - FORT ASSEMBLY

QTY	PART NUMBER	DESCRIPTION
16	H100088	SCREW PFH 8x1-1/8"



**M08** | WALL BOARD - W4L16074  
(x2) | 5/8"x3 3/8"x41" (16x86x1040)

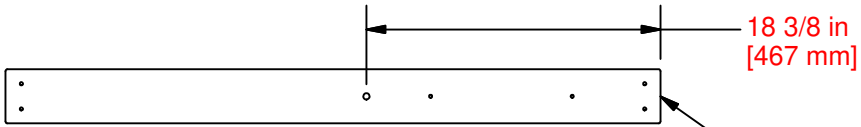

**M17** | WALL BOARD - W4L16090  
(x2) | 5/8"x3 3/8"x41" (16x86x1040)

**TOP**

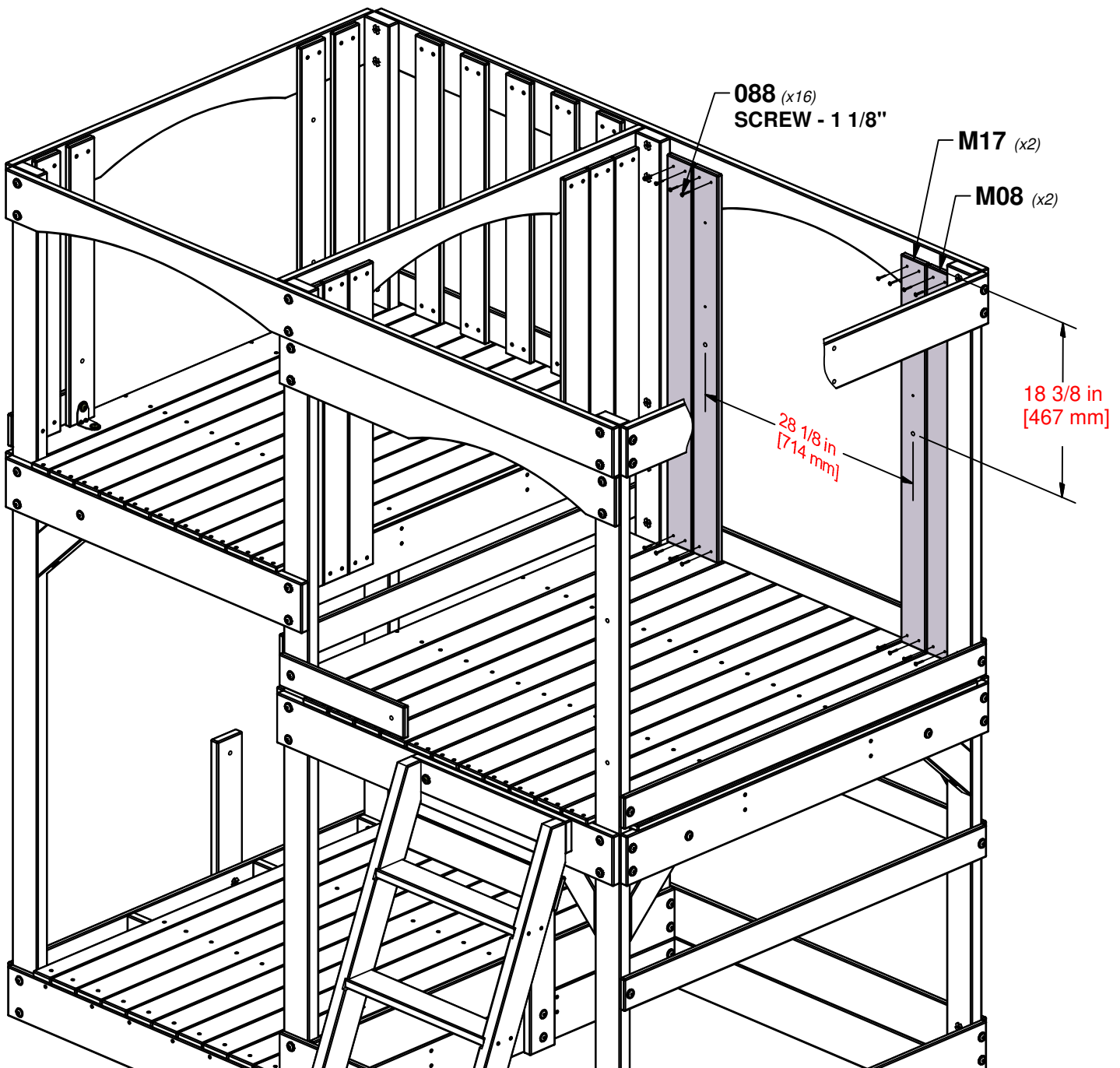



# STEP 21 - FORT ASSEMBLY

QTY	PART NUMBER	DESCRIPTION
2	H100009	BOLT WH 5/16x1 1/4
2	H100030	WASHER LOCK EXT 8x19
2	H100074	T-NUT 5/16
28	H100088	SCREW PFH 8x1-1/8"



**M12** WINDOW TRIM - W4L16048  
(x1) 5/8"x3 3/8"x31 1/2" (16x86x800)



**M13** WALL BOARD - W4L16049  
(x7) 5/8"x3 3/8"x24" (16x86x610)

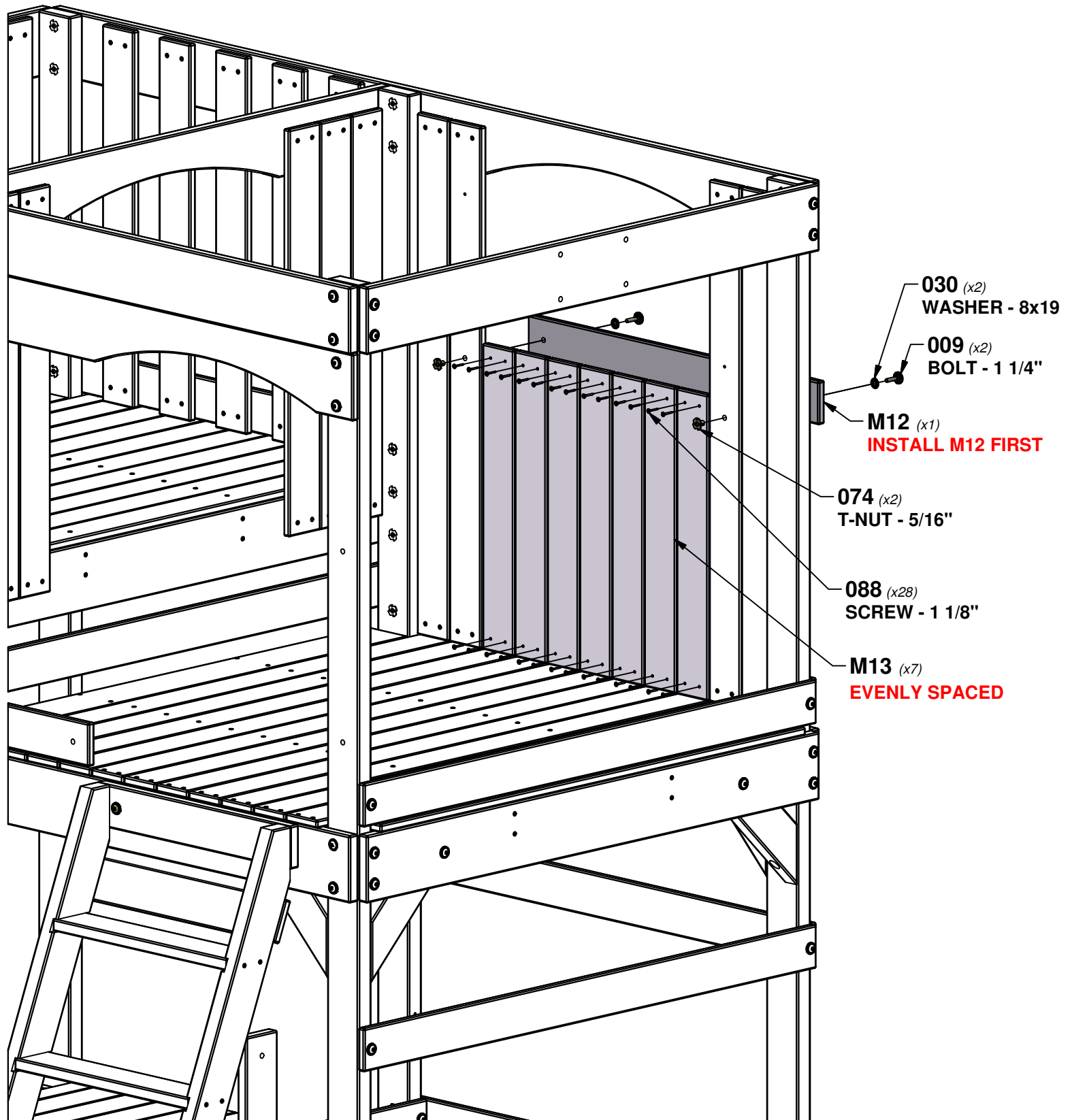

**030** (x2)  
WASHER - 8x19

**009** (x2)  
BOLT - 1 1/4"

**M12** (x1)  
**INSTALL M12 FIRST**

**074** (x2)  
T-NUT - 5/16"

**088** (x28)  
SCREW - 1 1/8"

**M13** (x7)  
**EVENLY SPACED**



# STEP 22 - FORT ASSEMBLY

QTY	PART NUMBER	DESCRIPTION
4	H100088	SCREW PFH 8x1-1/8"

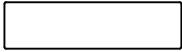

**M23** | WINDOW TRIM - W4L16059  
(x2) | 5/8"x3 3/8"x12 7/8" (16x86x328)

**SIDE VIEW**

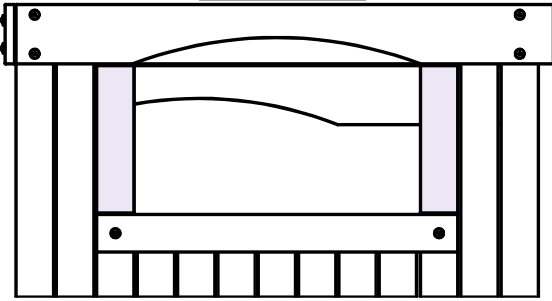

**CORRECT BOARD ASSEMBLY**

**088** (x4)  
SCREW - 1 1/8"

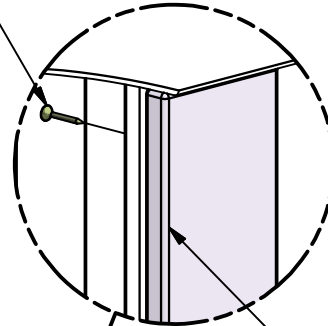

**M23** (x2)

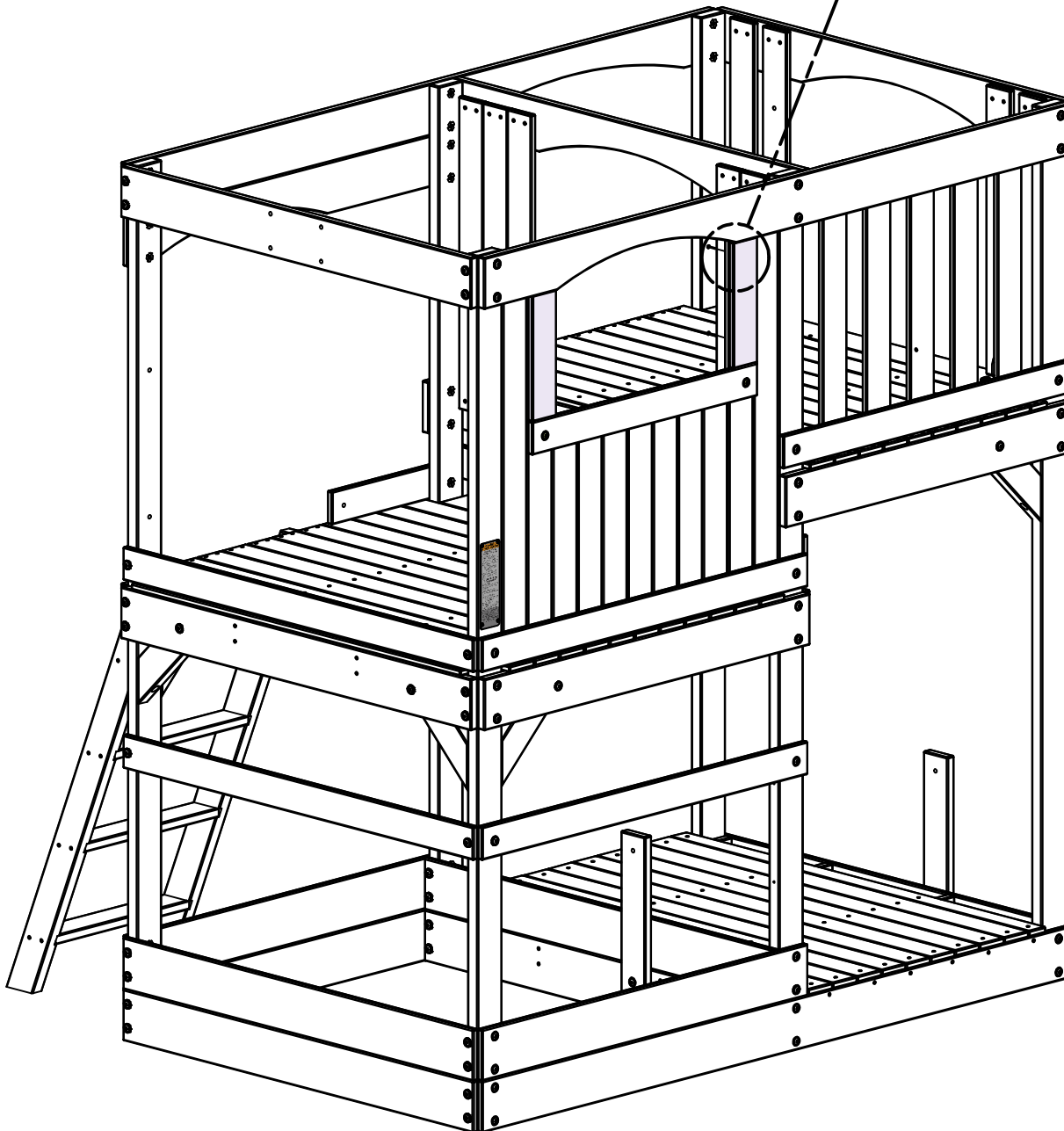

# STEP 23 - FORT ASSEMBLY

QTY	PART NUMBER	DESCRIPTION
48	H100088	SCREW PFH 8x1-1/8"



**M08** | WALL BOARD - W4L16074  
(x7) 5/8"x3 3/8"x41" (16x86x1040)

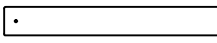

**N03** | WALL BOARD - W4L16078  
(x2) 5/8"x2 3/8"x18" (16x60x456)



**N05** | WALL BOARD - W4L16080  
(x2) 5/8"x2 3/8"x7" (16x60x178)



**L02** | WALL BOARD - W4L16040  
(x4) 5/8"x4 3/8"x18" (16x112x456)



**L03** | WALL BOARD - W4L16041  
(x4) 5/8"x4 3/8"x7" (16x112x178)

**FLUSH TOPS OF L03 & N05 BOARDS  
WITH TOP OF M08 BOARDS**

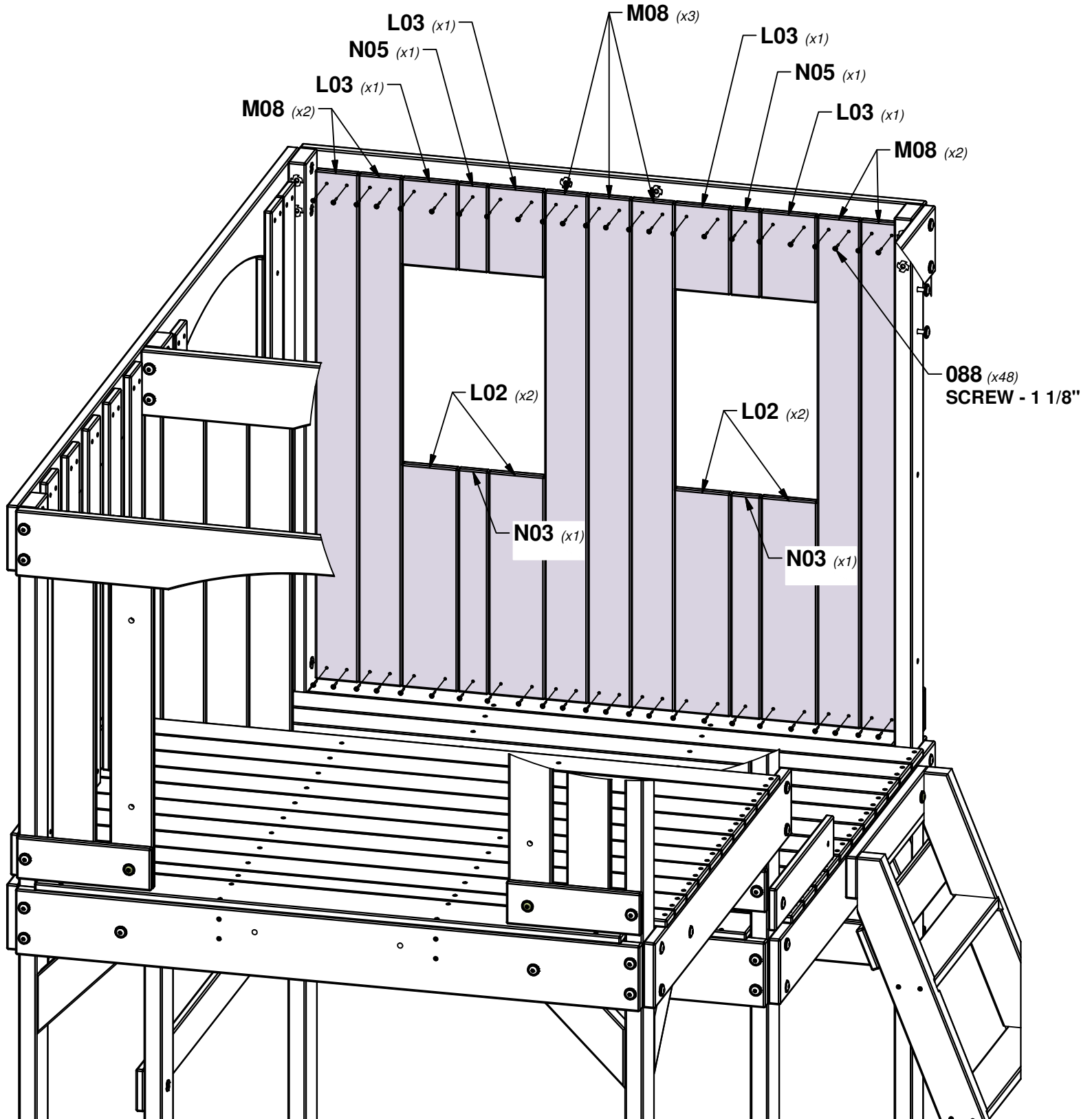

# STEP 24 - FORT ASSEMBLY

QTY	PART NUMBER	DESCRIPTION
8	H100070	SCREW PWH 8x3/4
10	H100088	SCREW PFH 8x1-1/8"

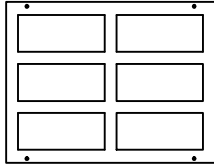

PLASTIC WINDOW BYD GREEN  
A100010 (x2)  
343x444.5



WALL SUPPORT - W4L16081  
O01 (x2)  
5/8"x1 3/8"x13" (16x34x330)

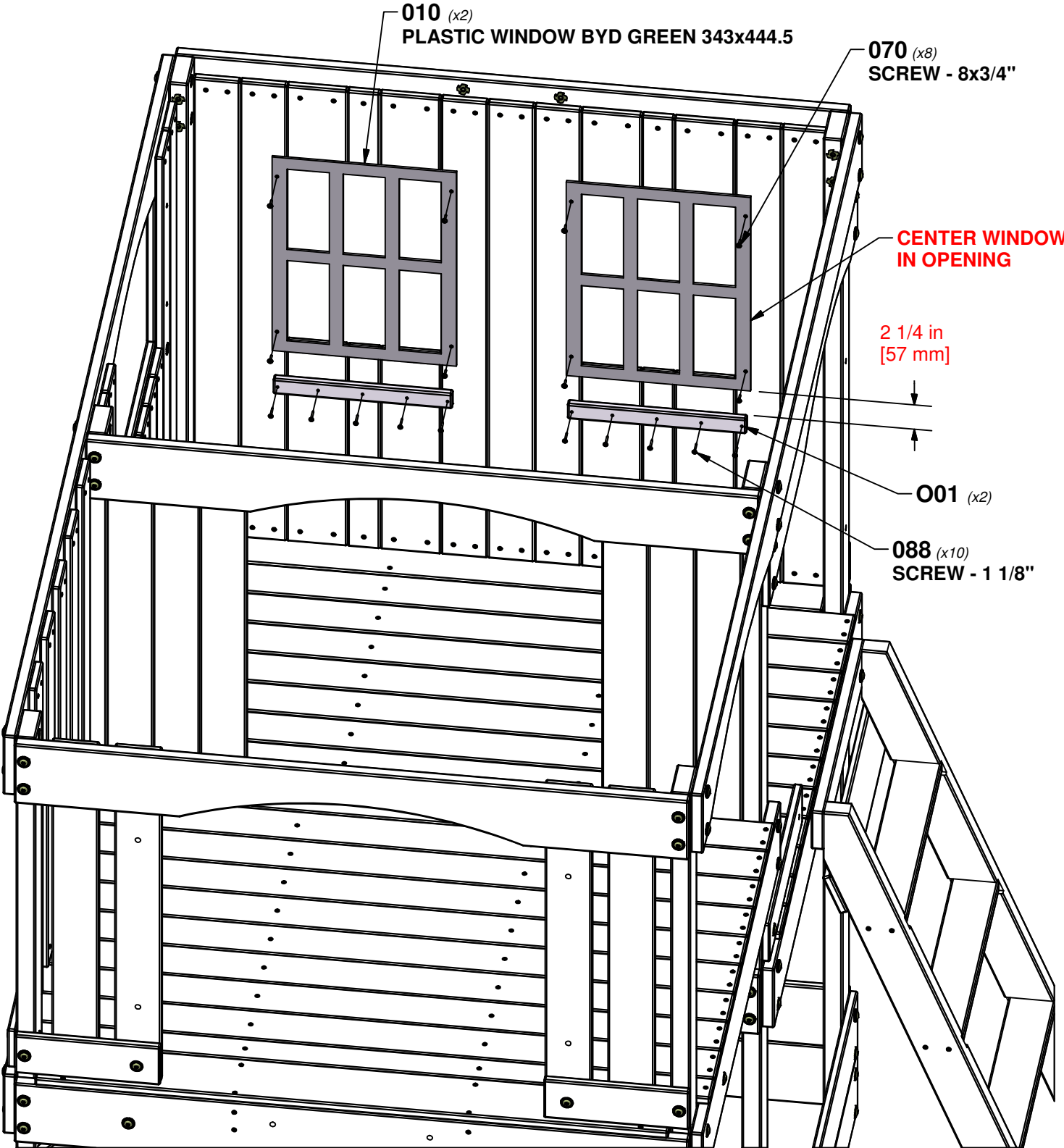

# STEP 25 - FORT ASSEMBLY

QTY	PART NUMBER	DESCRIPTION
12	H100086	SCREW PFH 8x1-1/2"

**O04** WINDOW SHUTTER SLAT - W4L16084  
 (x6) 5/8"x1 3/8"x5 3/8" (16x34x136)

**L04** WINDOW SHUTTER - W4L16042  
 (x3) 5/8"x4 3/8"x16" (16x112x406)

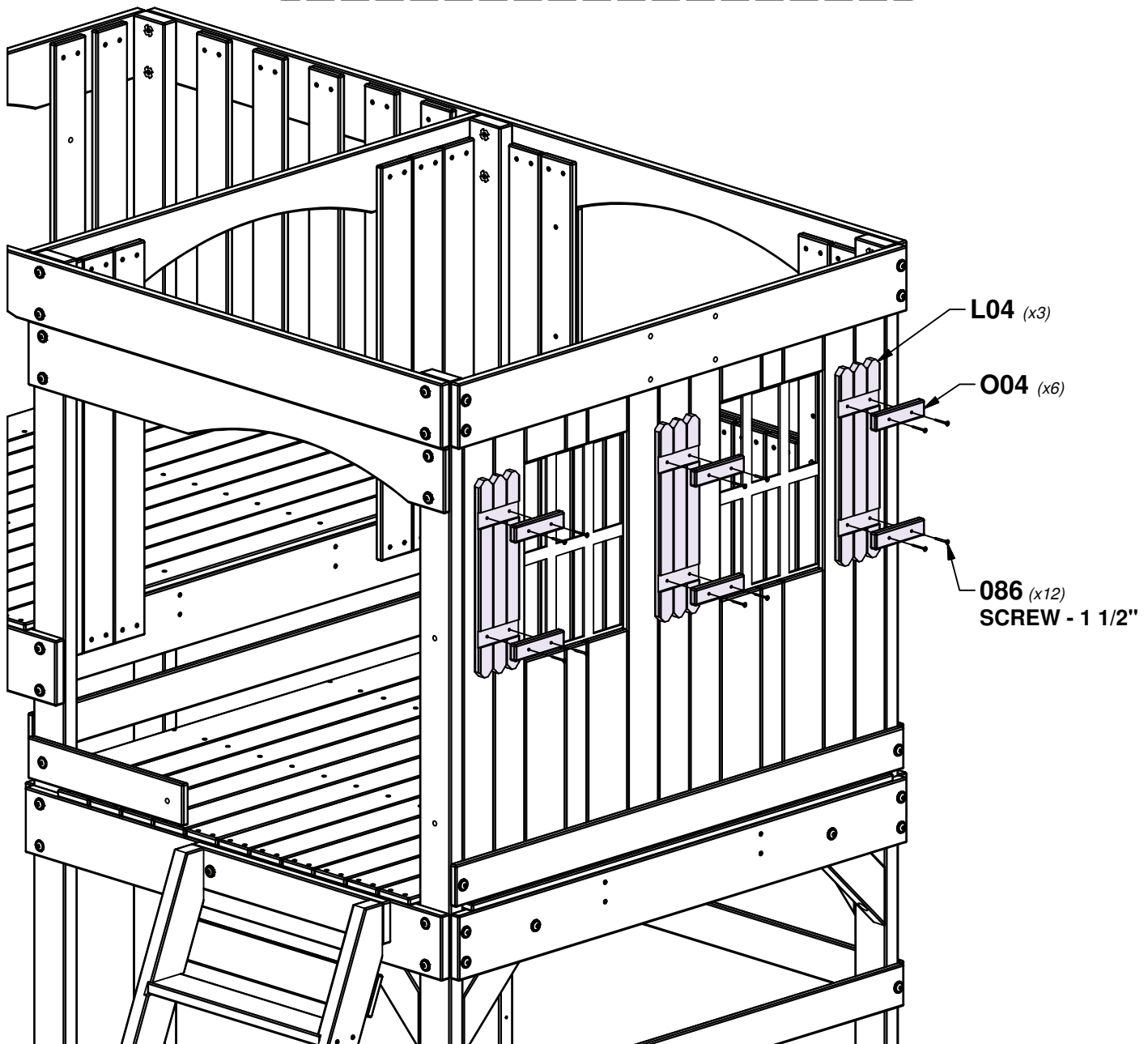
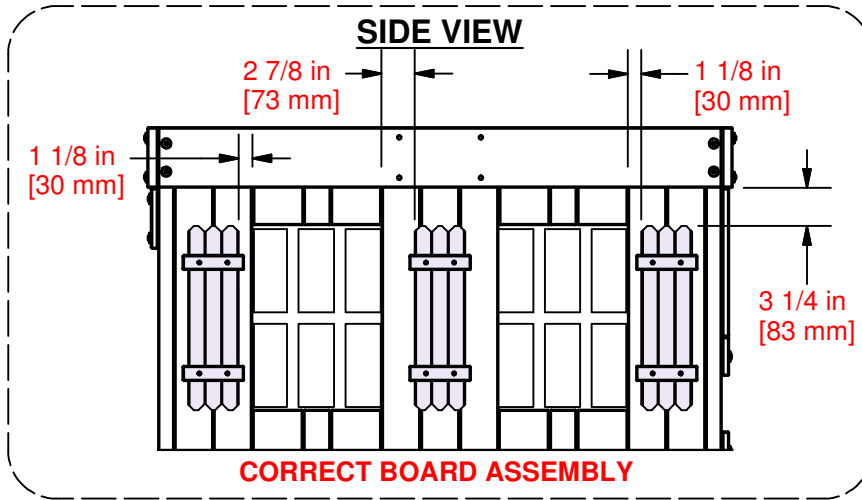

# STEP 26 - FORT ASSEMBLY

QTY	PART NUMBER	DESCRIPTION
1	H100005	NUT BARREL WH 5/16x7/8
1	H100008	BOLT WH 5/16x1
1	H100031	WASHER LOCK EXT 12x19
1	H100074	T-NUT 5/16
14	H100088	SCREW PFH 8x1-1/8"
1	H100115	BOLT WH 5/16x1/2



**M10** | WALL BOARD - W4L16044  
(x1) | 5/8"x3 3/8"x35" (16x86x888)

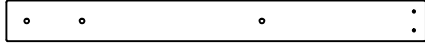

**M28** | WALL BOARD - W4L16064  
(x1) | 5/8"x3 3/8"x35" (16x86x888)



**A4M01046** | L BRACKET  
(x1) | 2.5x38x55x55

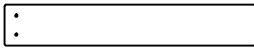

**M16** | WALL BOARD - W4L16052  
(x2) | 5/8"x3 3/8"x21" (16x86x532)



**M29** | WALL BOARD - W4L16060  
(x2) | 5/8"x3 3/8"x5" (16x86x126)

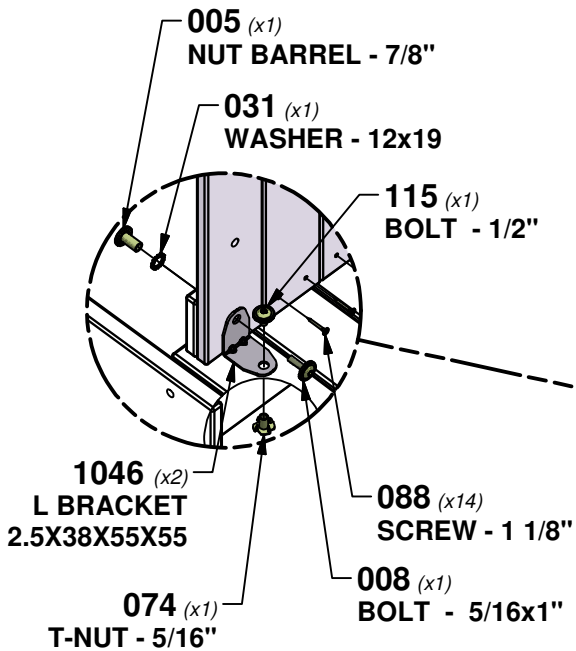

**USING L BRACKET AS A GUIDE,  
DRILL (1) 3/8 in [10 mm] HOLES  
THRU FLOOR FOR HARDWARE**

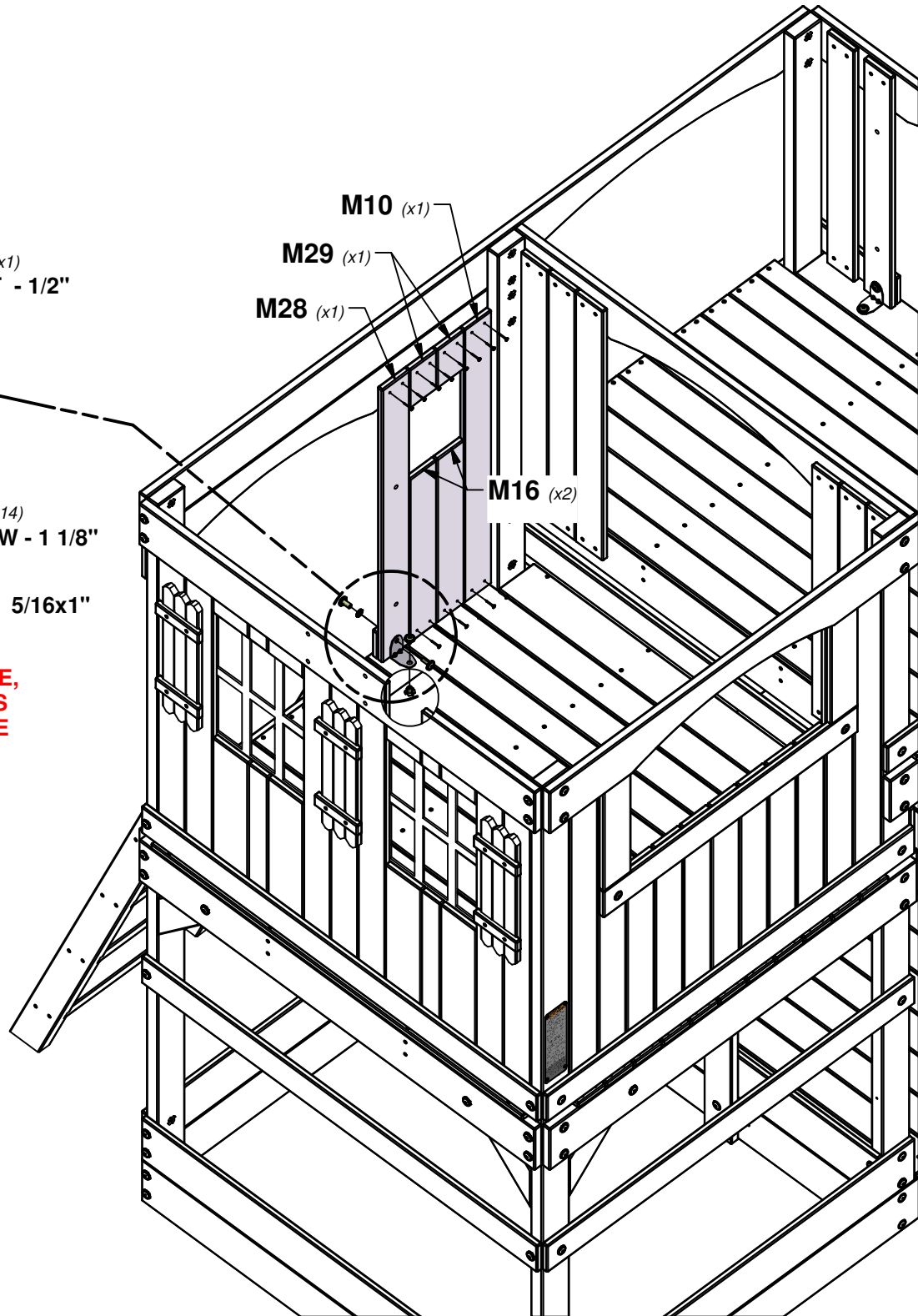

# STEP 27 - FORT ASSEMBLY

QTY	PART NUMBER	DESCRIPTION
4	H100070	SCREW PWH 8x3/4
4	H100088	SCREW PFH 8x1-1/8"

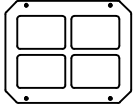

A100146 | WINDOW  
(x1) | 216x267 GREEN

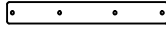

O02 | WALL SUPPORT - W4L16082  
(x1) | 5/8"x1 3/8"x10" (16x34x254)

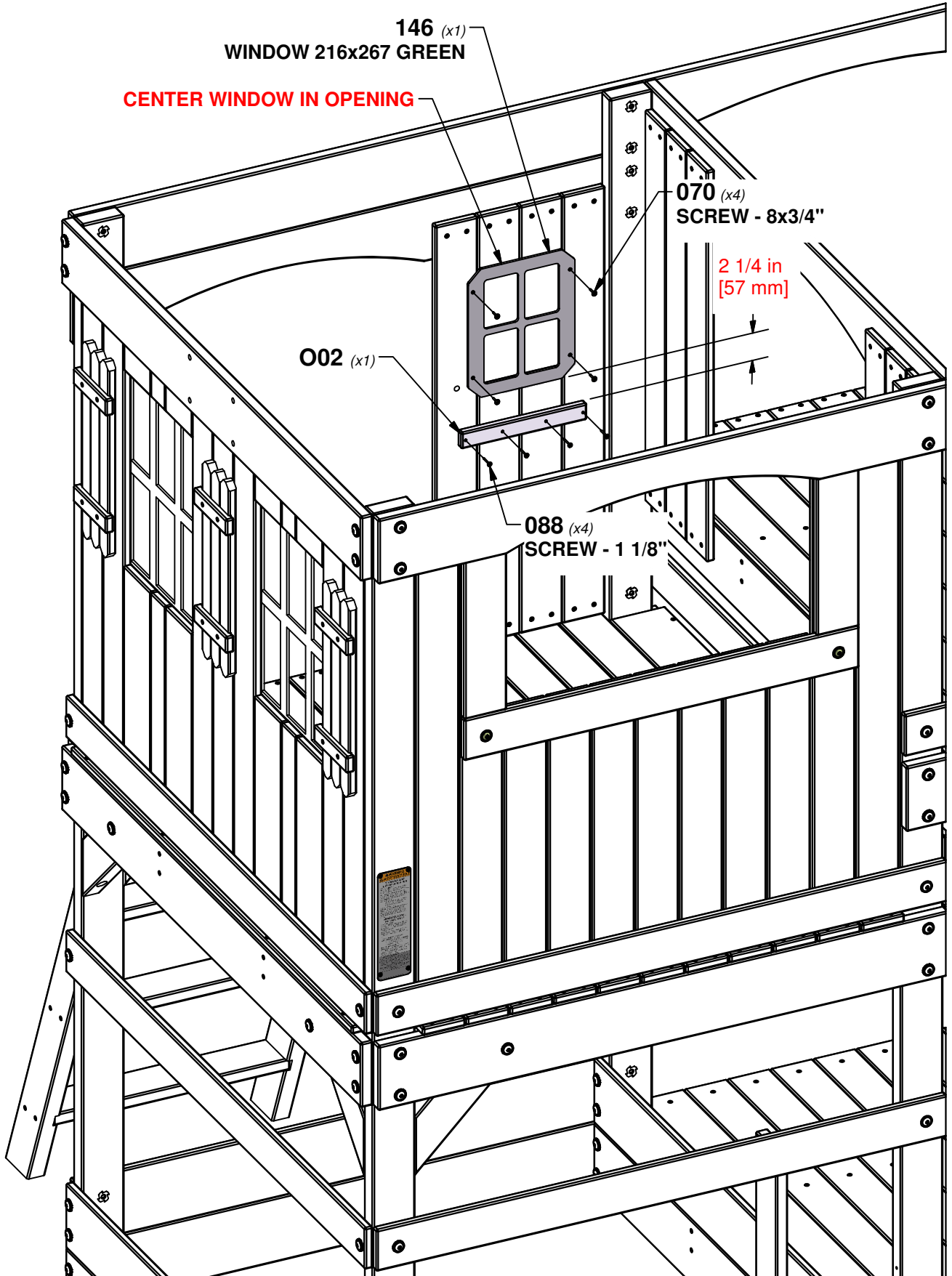

# STEP 28 - FORT ASSEMBLY

QTY	PART NUMBER	DESCRIPTION
8	H100086	SCREW PFH 8x1-1/2"
2	H100111	SCREW PFH 8x2

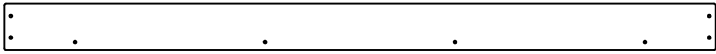

**M01** | ROOF CAP - W4L16043  
(x2) | 5/8"x3 3/8"x51 7/8" (16x86x1318)

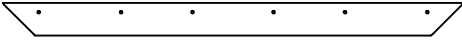

**J01** | ROOF RAFTER - W4L16033  
(x4) | 1"x2 3/8"x33 5/8" (24x60x854)

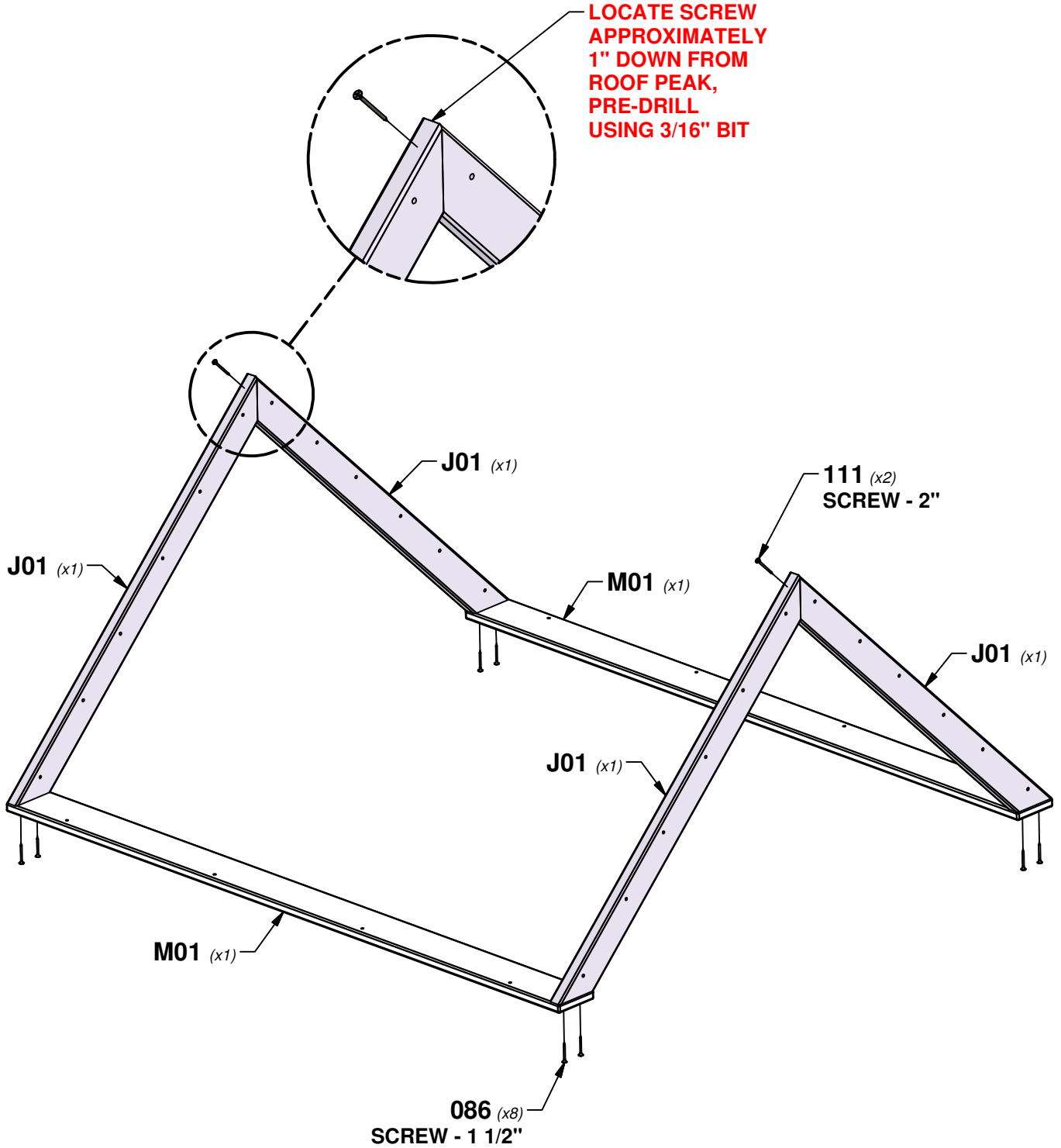



# STEP 29 - FORT ASSEMBLY

QTY	PART NUMBER	DESCRIPTION
8	H100090	SCREW PFH 8x2 1/2



**ROOF BASE ASSEMBLY**

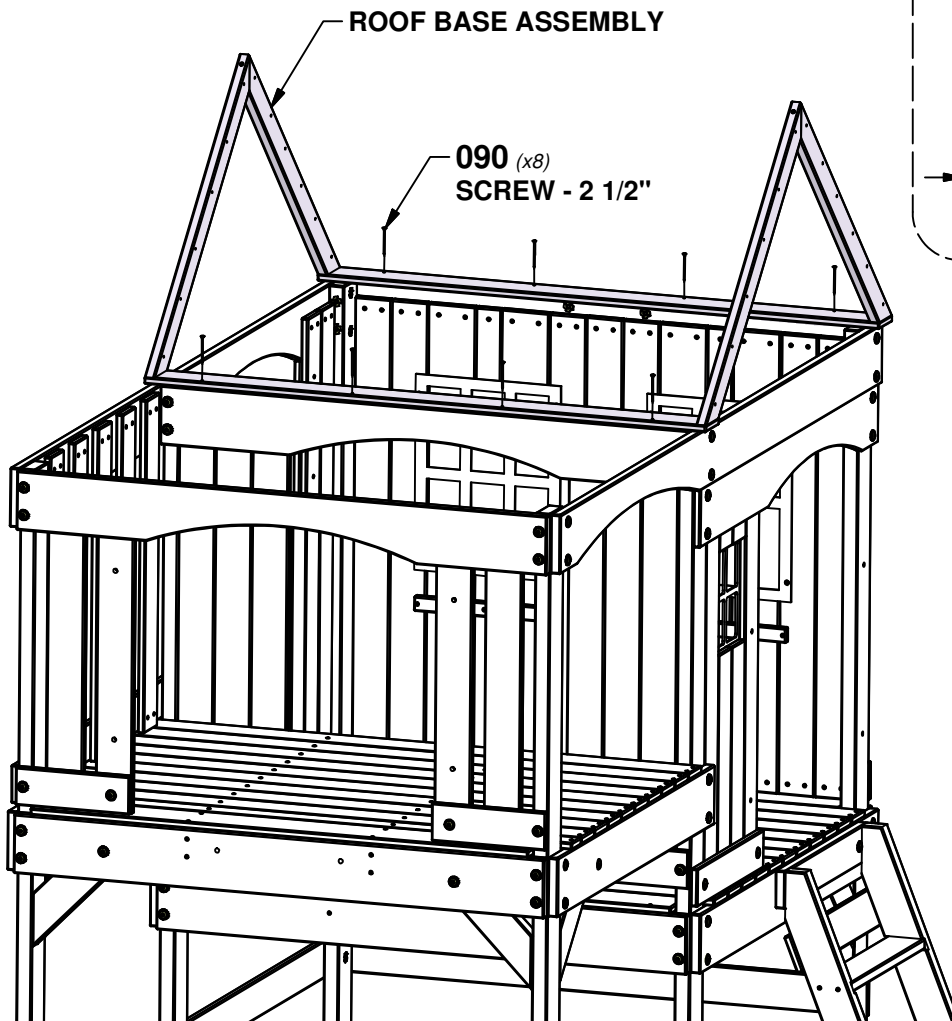
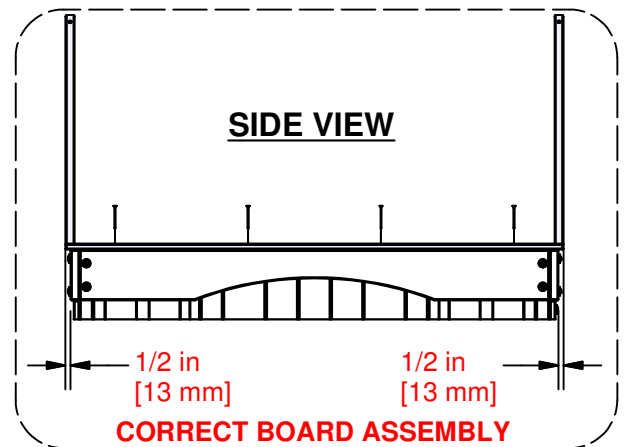
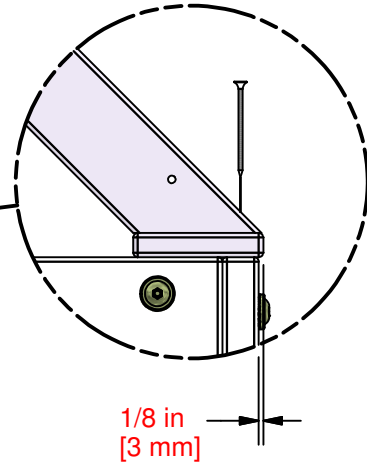
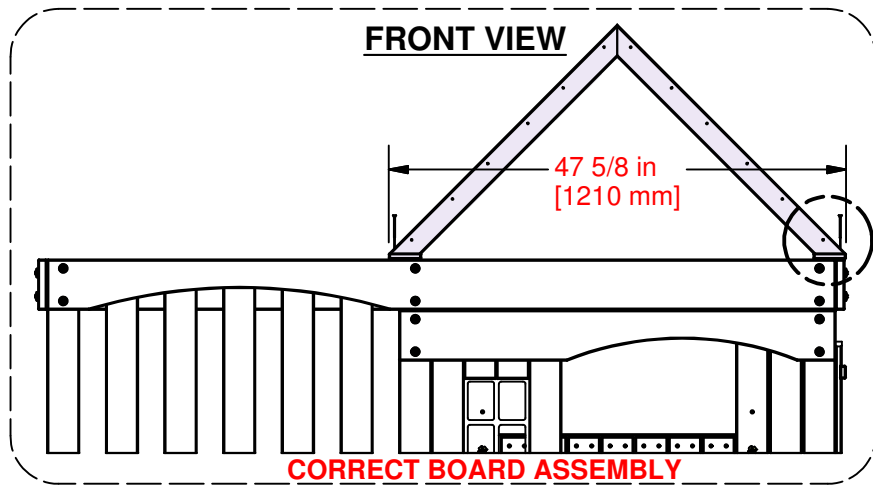



# STEP 30 - FORT ASSEMBLY

QTY	PART NUMBER	DESCRIPTION
6	H100090	SCREW PFH 8x2 1/2

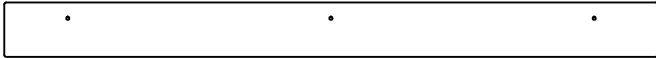

**M07** | WALL CAP - W4L16068  
 (x2) | 5/8"x3 3/8"x40 7/8" (16x86x1038)

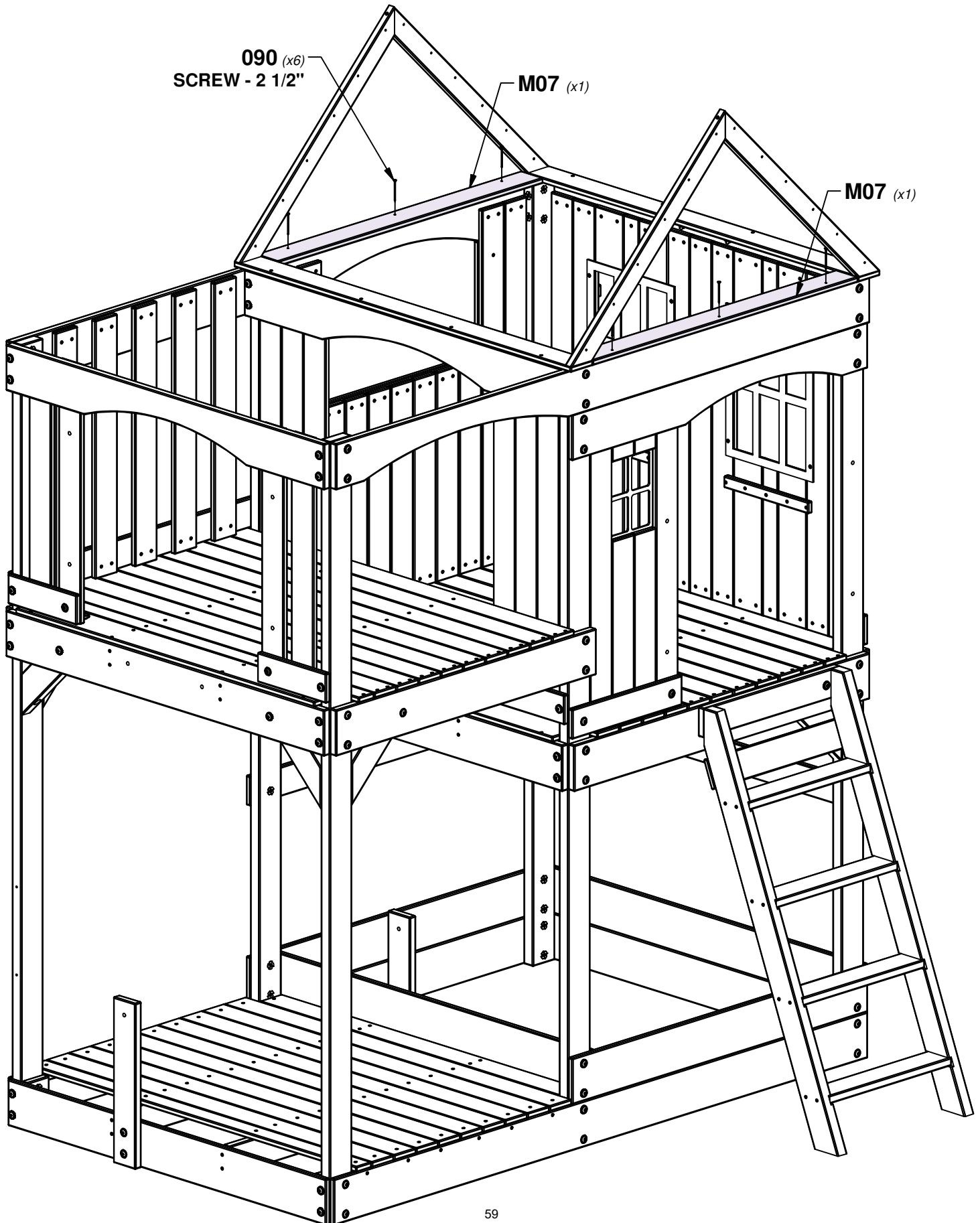

# STEP 31 - FORT ASSEMBLY

QTY	PART NUMBER	DESCRIPTION
44	H100088	SCREW PFH 8x1-1/8"

**M19** | GABLE BOARD - W4L16054  
(x4) | 5/8"x3 3/8"x15 1/4" (16x86x387)

**M22** | GABLE BOARD - W4L16058  
(x4) | 5/8"x3 3/8"x9 1/2" (16x86x241)

**N04** | GABLE BOARD - W4L16079  
(x4) | 5/8"x2 3/8"x11 7/8" (16x60x301)

**M04** | GABLE BOARD - W4L16065  
(x2) | 5/8"x3 3/8"x44" (16x86x1118)

**M20** | GABLE BOARD - W4L16056  
(x2) | 5/8"x3 3/8"x12 1/4" (16x86x310)

**M15** | GABLE BOARD - W4L16051  
(x2) | 5/8"x3 3/8"x19" (16x86x482)

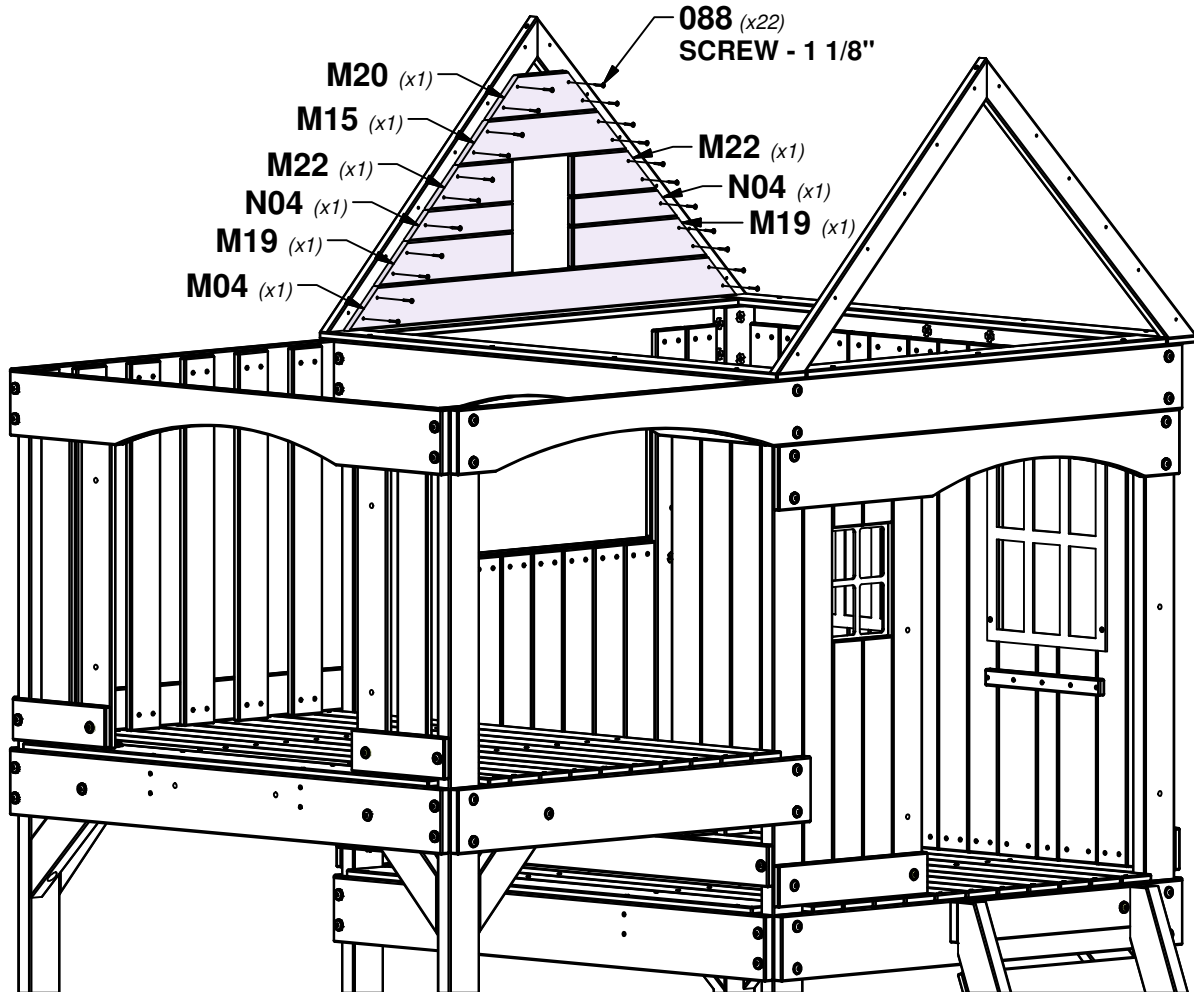
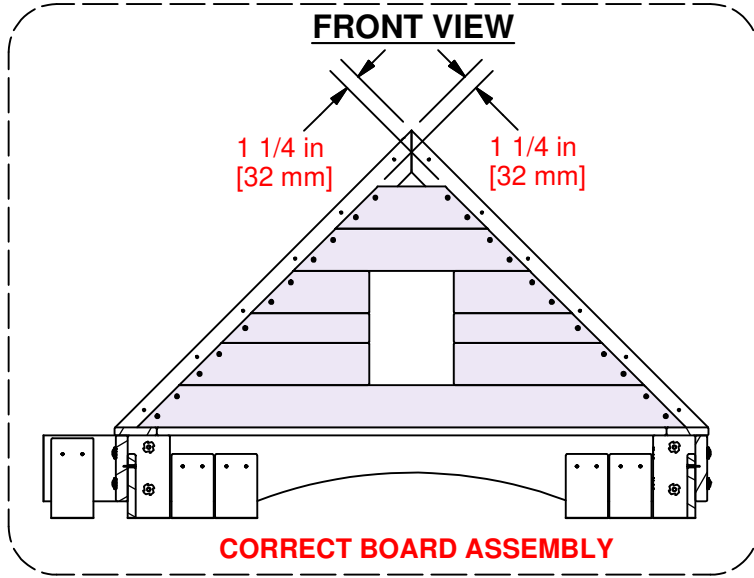

# STEP 32 - FORT ASSEMBLY

QTY	PART NUMBER	DESCRIPTION
8	H100070	SCREW PWH 8x3/4
20	H100088	SCREW PFH 8x1-1/8"

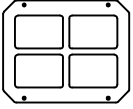

A100146 WINDOW  
(x2) 216x267 GREEN

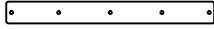

O01 WALL SUPPORT - W4L16081  
(x4) 5/8"x1 3/8"x13" (16x34x330)

## FRONT VIEW

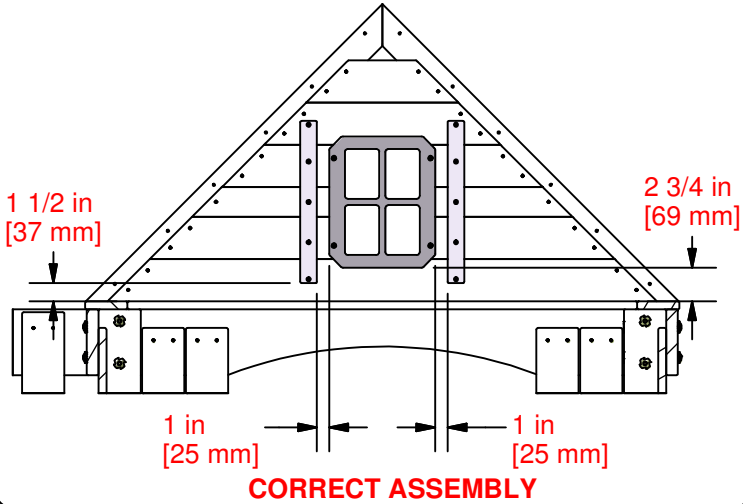

**REPEAT STEPS 31 & 32 ON THE OPPOSITE SIDE.**

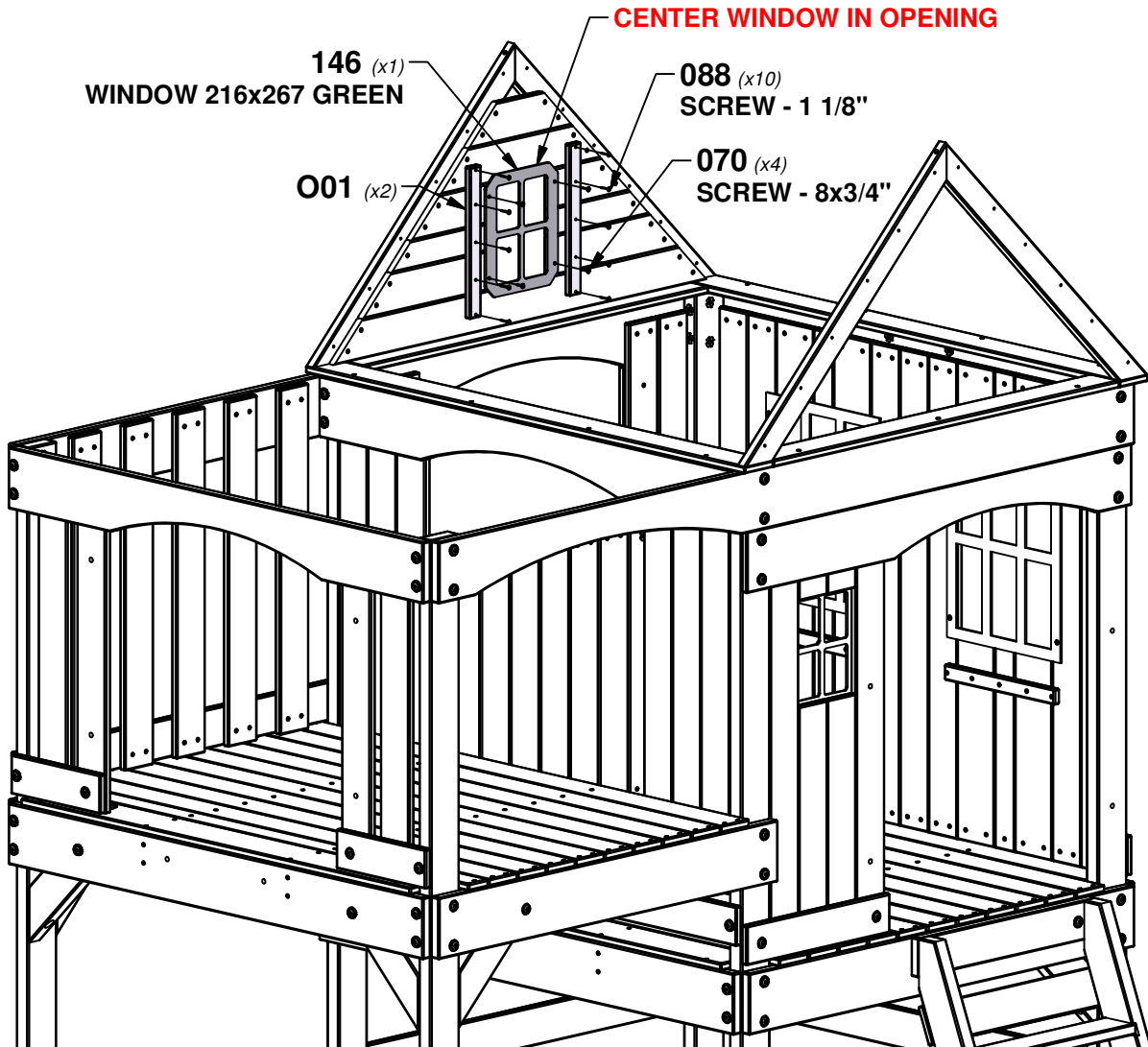

# STEP 33 - FORT ASSEMBLY

QTY	PART NUMBER	DESCRIPTION
24	H100089	SCREW PFH 8x1-3/4"



**RP1** | ROOF PANEL - W2A03279  
(x2) | 1 3/4"x19 1/4"x53 3/4" (45x490x1366)

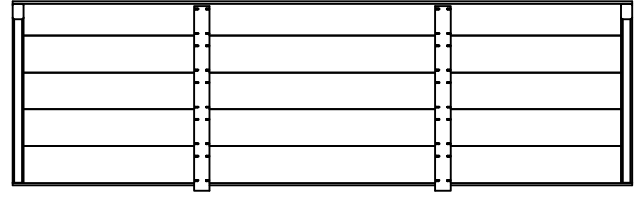

**RP2** | ROOF PANEL - W2A03280  
(x2) | 1 3/4"x16 1/4"x53 3/4" (45x417x1366)

**REPEAT THIS STEP FOR THE OPPOSITE SIDE.**

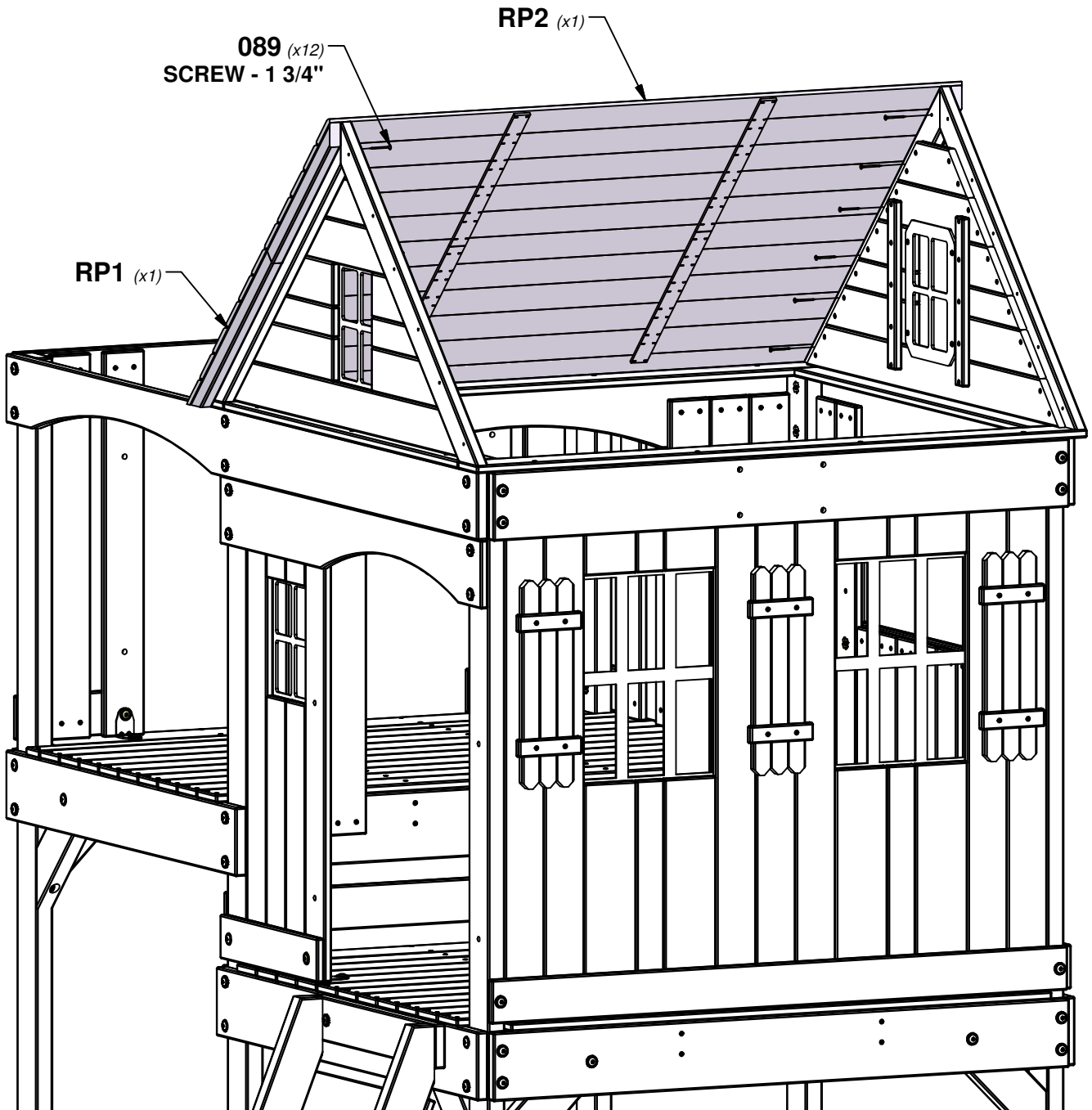

# STEP 34 - FORT ASSEMBLY

QTY	PART NUMBER	DESCRIPTION
4	H100088	SCREW PFH 8x1-1/8"

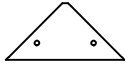

**N02** | MENDING PLATE - W4L16077  
(x2) | 5/8"x2 3/8"x5" (16x60x126)

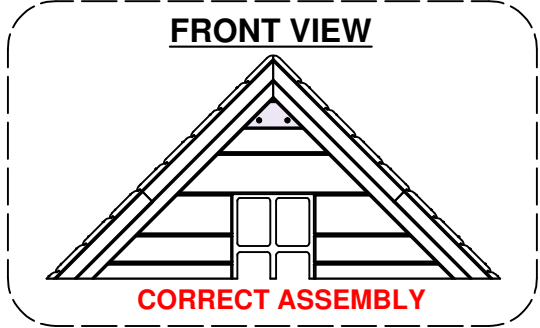
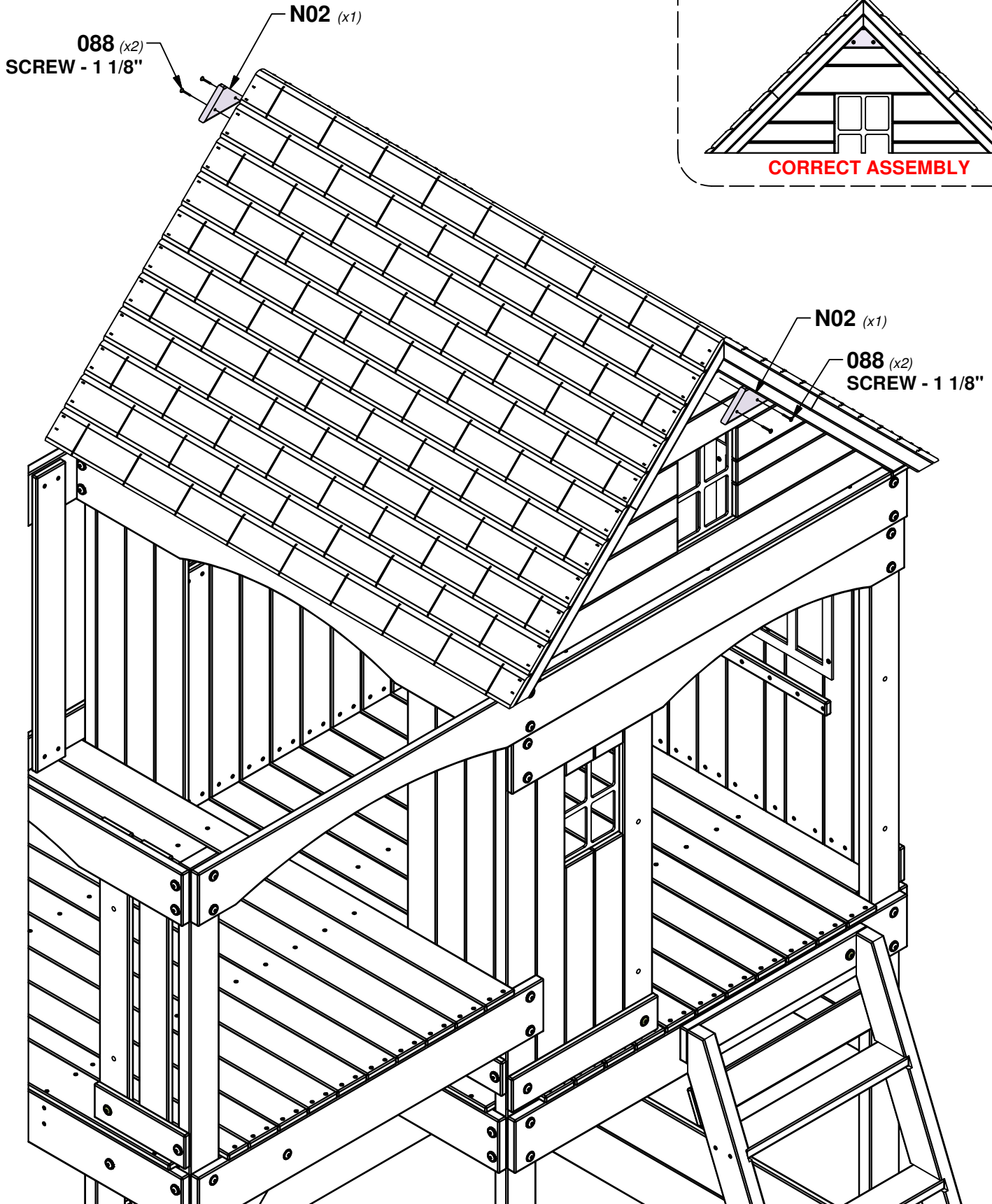

# STEP 35 - FORT ASSEMBLY

QTY	PART NUMBER	DESCRIPTION
2	H100010	BOLT WH 5/16x1 1/2
8	H100074	T-NUT 5/16
6	H100115	BOLT WH 5/16x1/2



**A100118** | **HAND GRIP**  
 (x4) | **METAL GREEN**  
 381 c/c

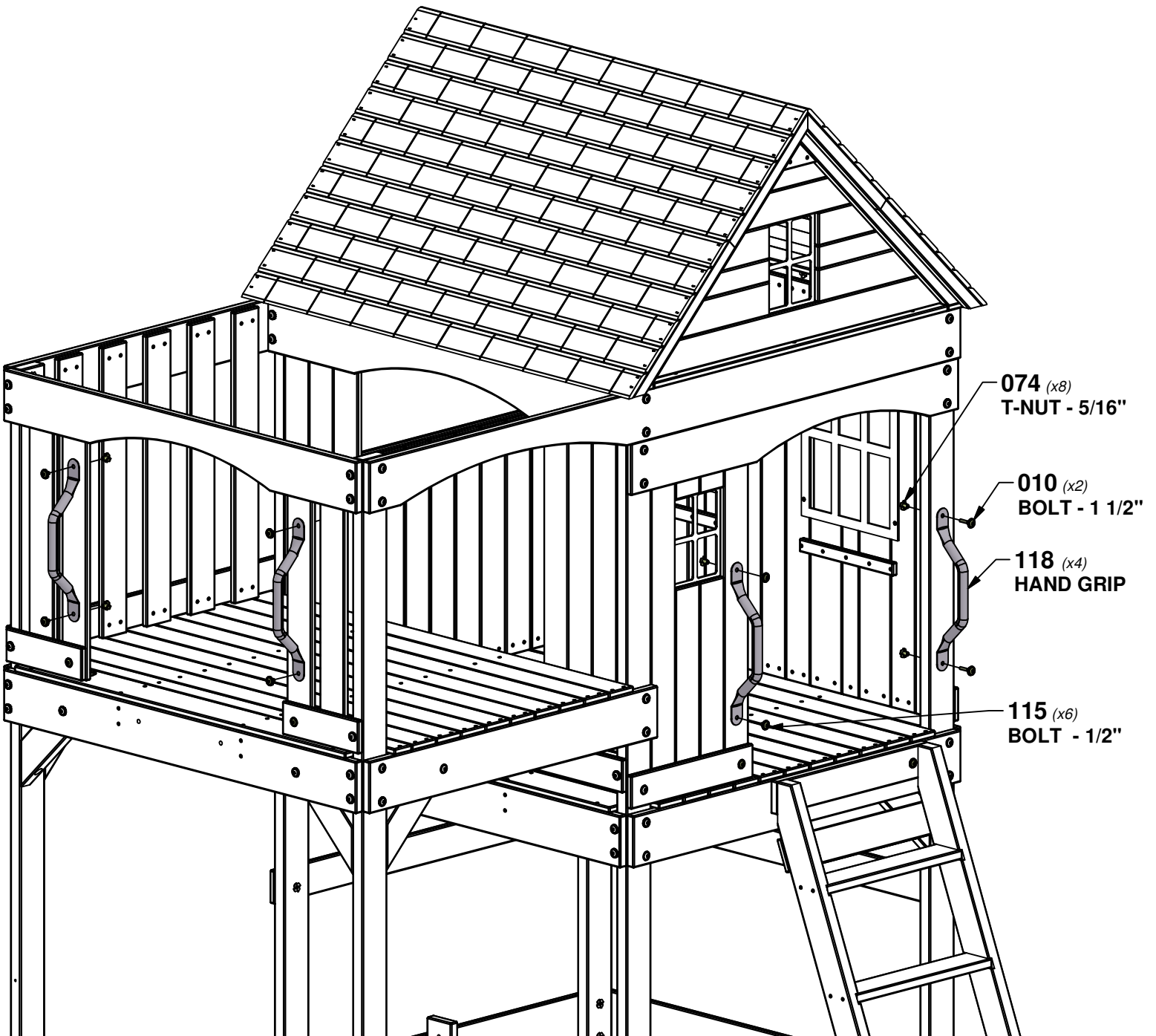

# STEP 36 - FORT ASSEMBLY

QTY	PART NUMBER	DESCRIPTION
8	H100086	SCREW PFH 8x1-1/2"

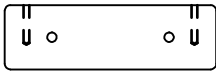

**T01** SEAT SUPPORT - W4L16086  
(x4) 1"x1 3/8"x5" (24x34x128)

## PLACEMENT VIEWS

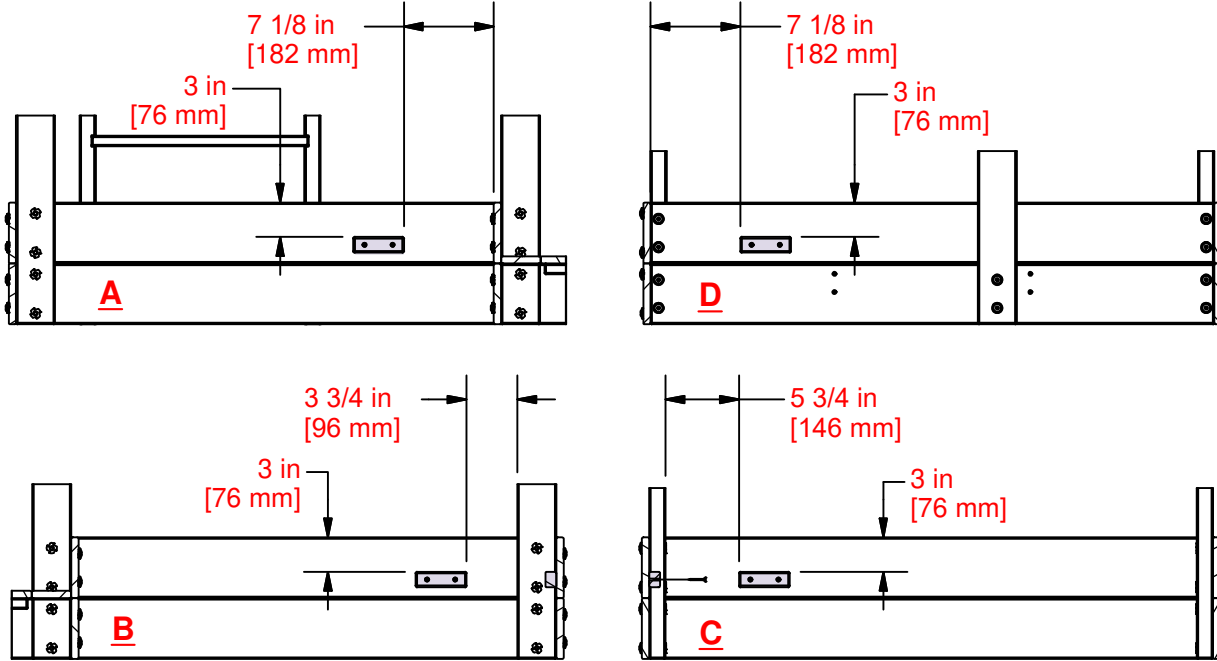

SEE LOCATIONS BELOW (A, B, C, & D)

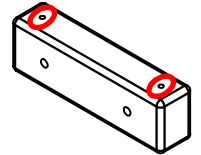

INSTALL T01  
WITH SMALL  
PILOT HOLES  
UPWARD

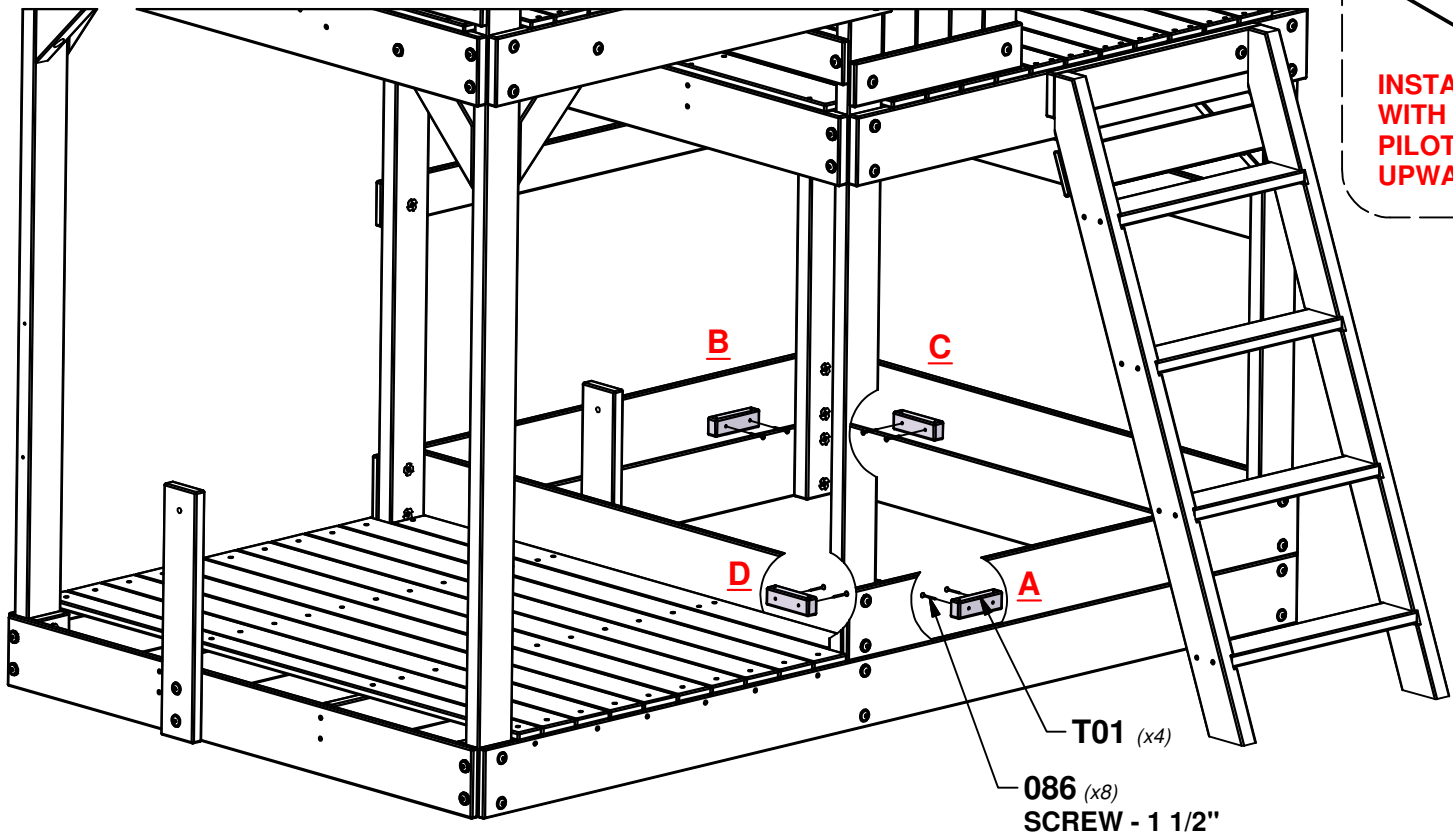

**086** (x8)  
SCREW - 1 1/2"

**T01** (x4)



# STEP 37 - FORT ASSEMBLY

QTY	PART NUMBER	DESCRIPTION
8	H100089	SCREW PFH 8x1-3/4"



**G13** SAND BOX SEAT - W4L16013  
(x2) | 1"x5 1/4"x17 3/4" (24x134x450)

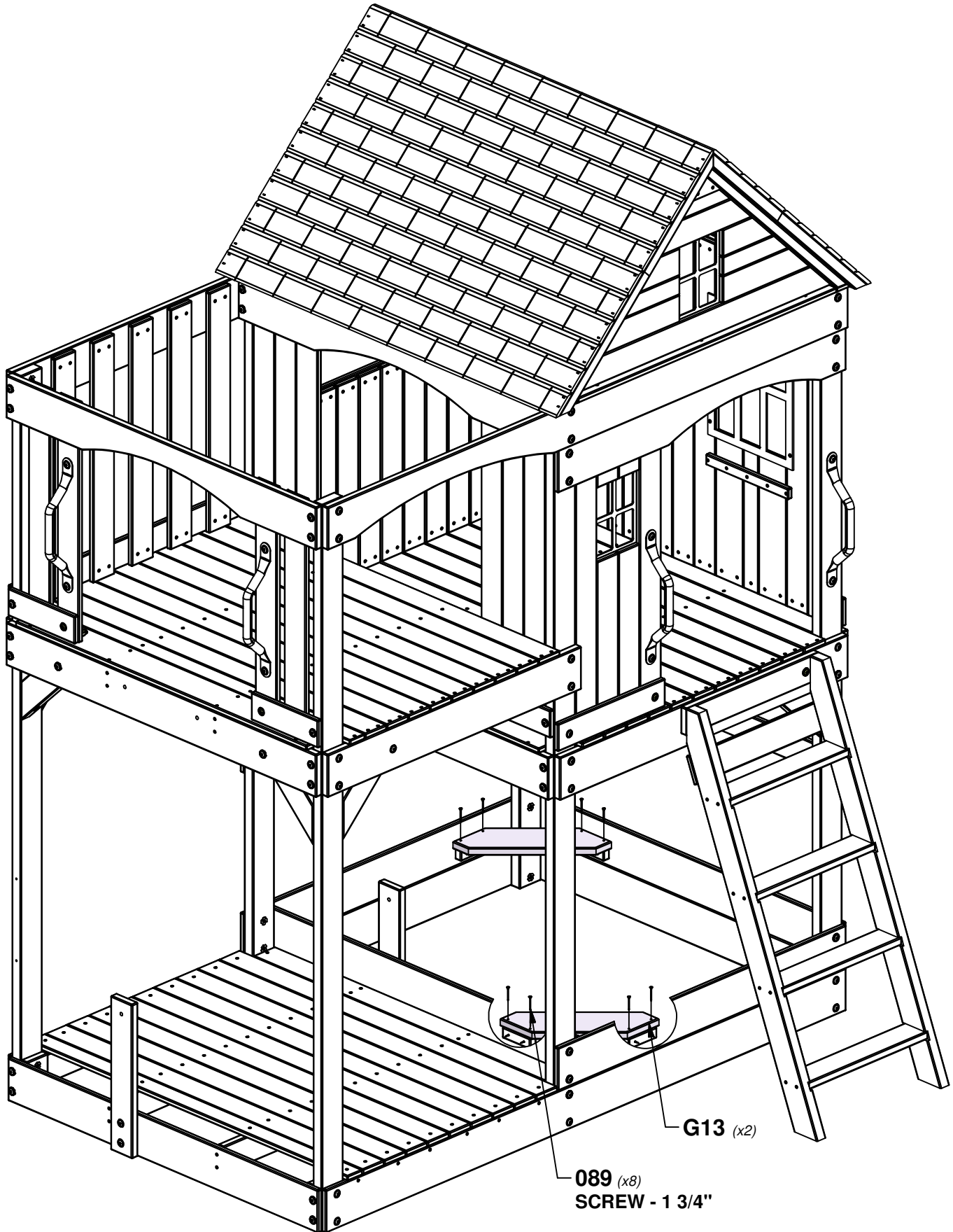



# STEP 38 - FORT ASSEMBLY

QTY	PART NUMBER	DESCRIPTION
24	H100088	SCREW PFH 8x1-1/8"



**M27** | BOTTOM WALL BOARD - W4L16062  
 (x6) | 5/8" x 3 3/8" x 21 3/8" (16x86x544)

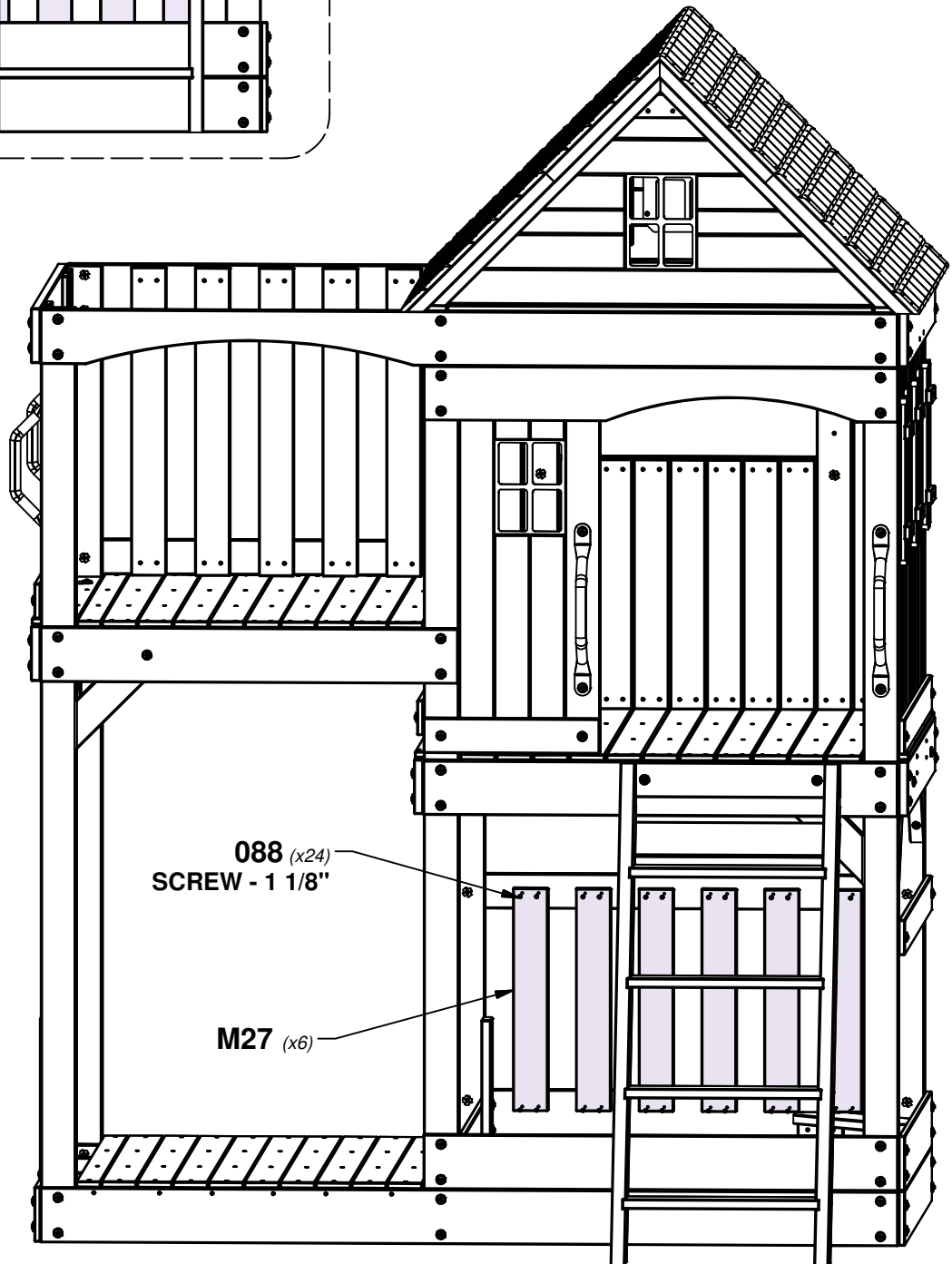
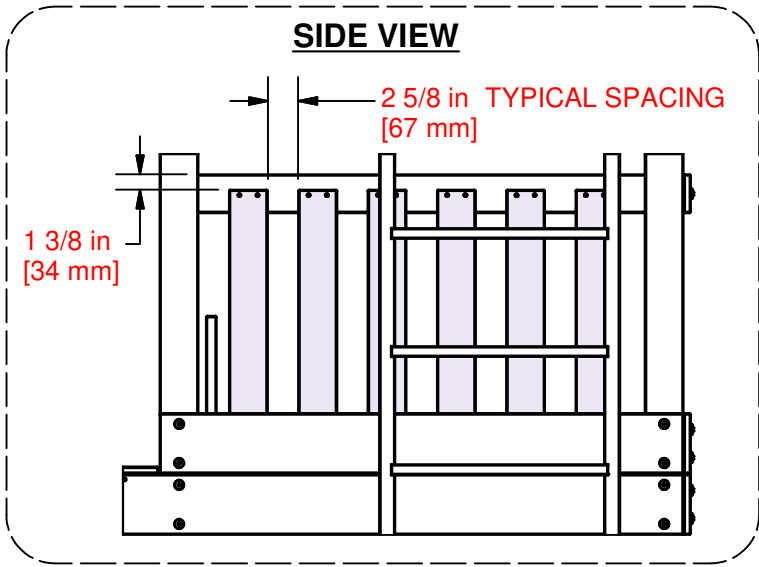

# STEP 39 - FORT ASSEMBLY

QTY	PART NUMBER	DESCRIPTION
28	H100088	SCREW PFH 8x1-1/8"

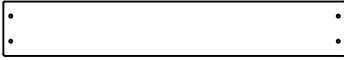

**M27** | BOTTOM WALL BOARD - W4L16062  
(x7) 5/8"x3 3/8"x21 3/8" (16x86x544)

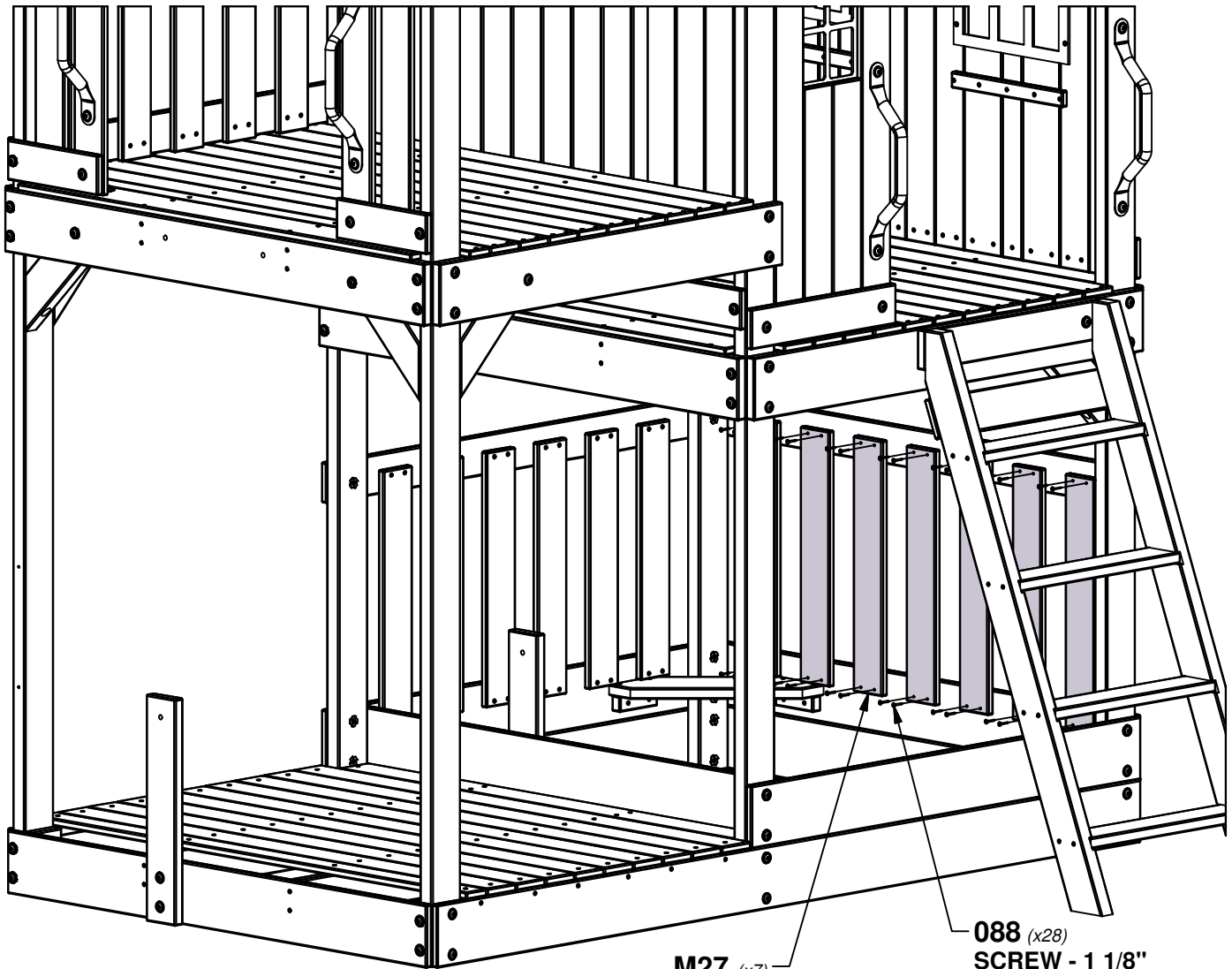
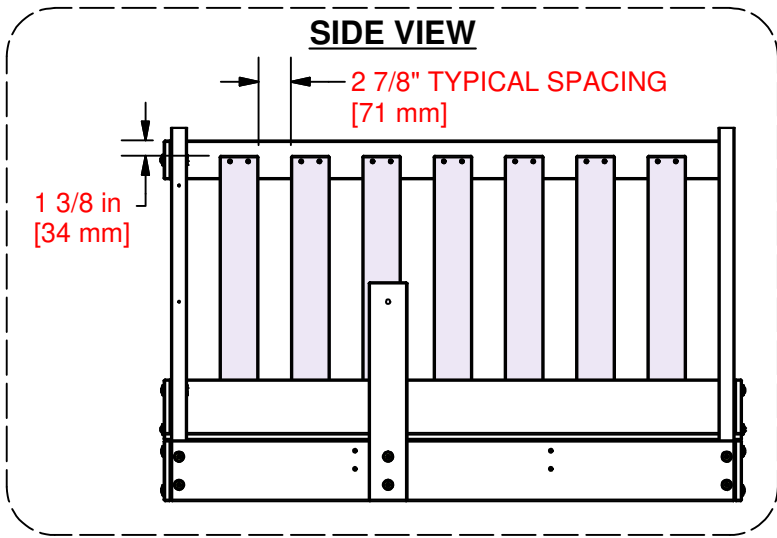

**M27** (x7)

**088** (x28)  
**SCREW - 1 1/8"**

# STEP 40 - FORT ASSEMBLY

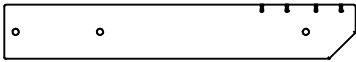

**M14** | PICNIC SEAT SUPPORT - W4L16050  
 (x2) | 5/8"x3 3/8"x22" (16x86x558)

QTY	PART NUMBER	DESCRIPTION
2	H100010	BOLT WH 5/16x1 1/2
2	H100028	LAG SCREW WH 5/16x2 1/2
4	H100030	WASHER LOCK EXT 8x19
2	H100074	T-NUT 5/16

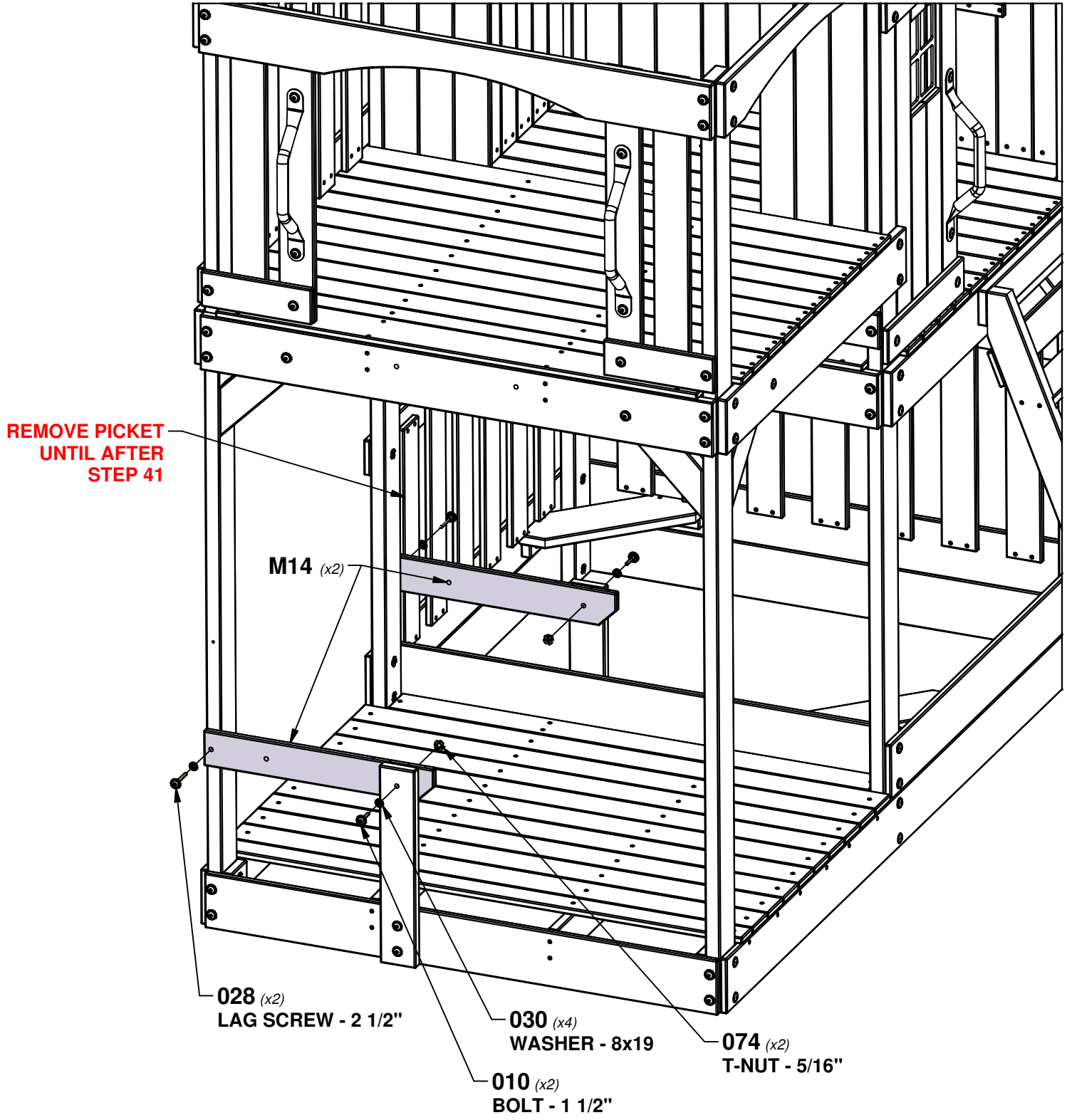

# STEP 41 - FORT ASSEMBLY

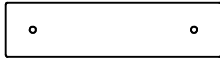

**M25** TABLE SUPPORT - W4L16037  
(x2) 5/8"x3 3/8"x13 1/2" (16x86x342)

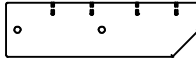

**H08** TABLE SUPPORT - W4L16031  
(x2) 1"x3 3/8"x12" (24x86x306)

QTY	PART NUMBER	DESCRIPTION
2	H100009	BOLT WH 5/16x1 1/4
2	H100010	BOLT WH 5/16x1 1/2
2	H100028	LAG SCREW WH 5/16x2 1/2
6	H100030	WASHER LOCK EXT 8x19
4	H100074	T-NUT 5/16

**TIP:**  
INSTALL T-NUTS IN WOOD FIRST

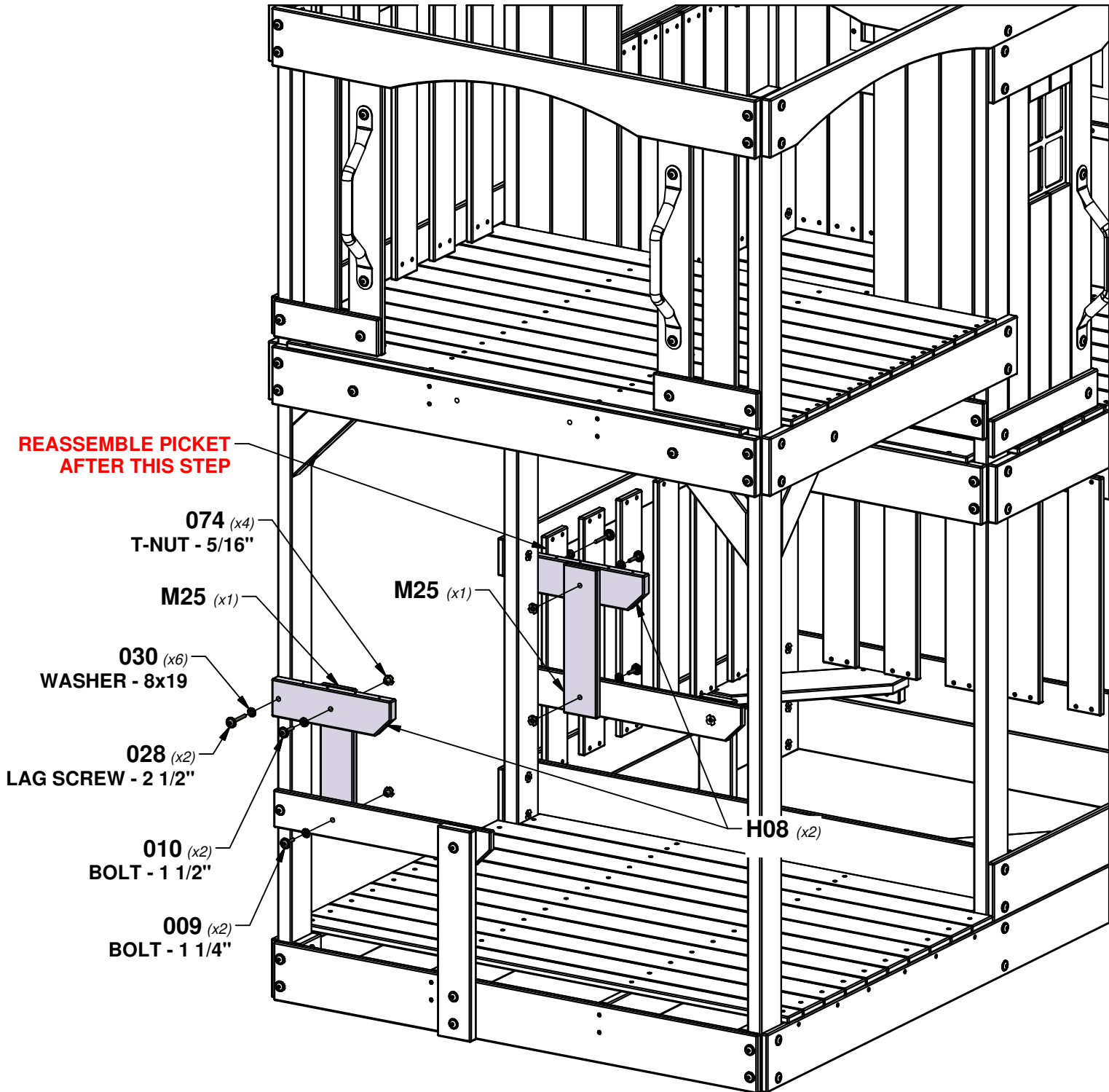

# STEP 42 - FORT ASSEMBLY

QTY	PART NUMBER	DESCRIPTION
1	H100088	SCREW PFH 8x1-1/8"
1	H100089	SCREW PFH 8x1-3/4"

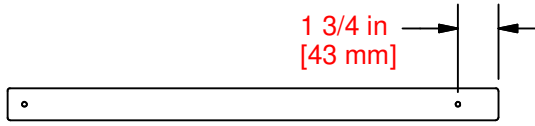

**O03** SAFETY RAIL - W4L16083  
(x1) 5/8"x1 3/8"x20 1/2" (16x34x520)

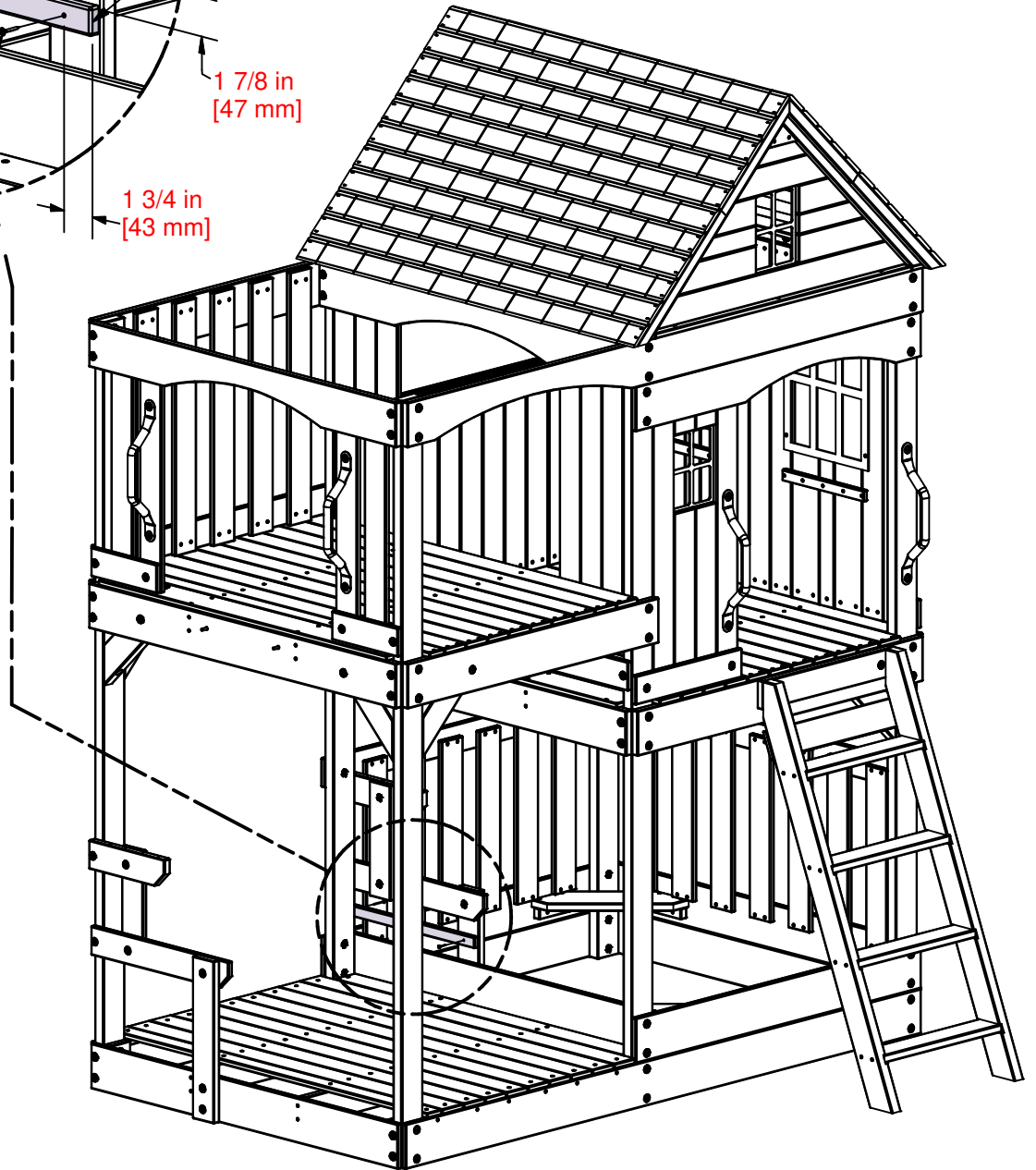
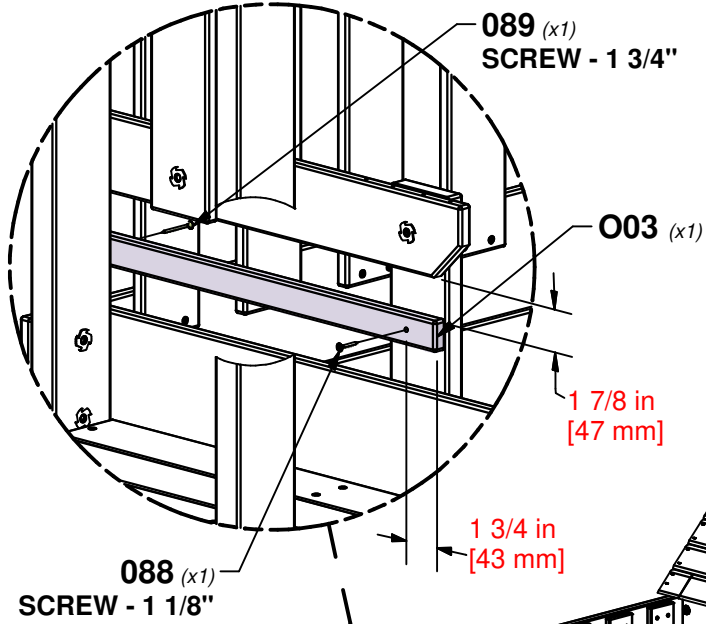

# STEP 43 - FORT ASSEMBLY

QTY	PART NUMBER	DESCRIPTION
16	H100089	SCREW PFH 8x1-3/4"



**H02** | PICNIC TABLE SEAT - W4L16025  
(x2) | 1"x3 3/8"x41 3/8" (24x86x1050)

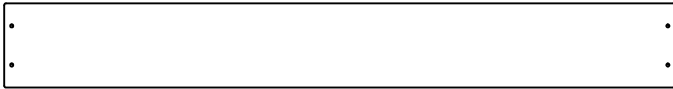

**G11** | PICNIC TABLE TOP - W4L16011  
(x2) | 5/8"x5 1/4"x42" (16x134x1066)

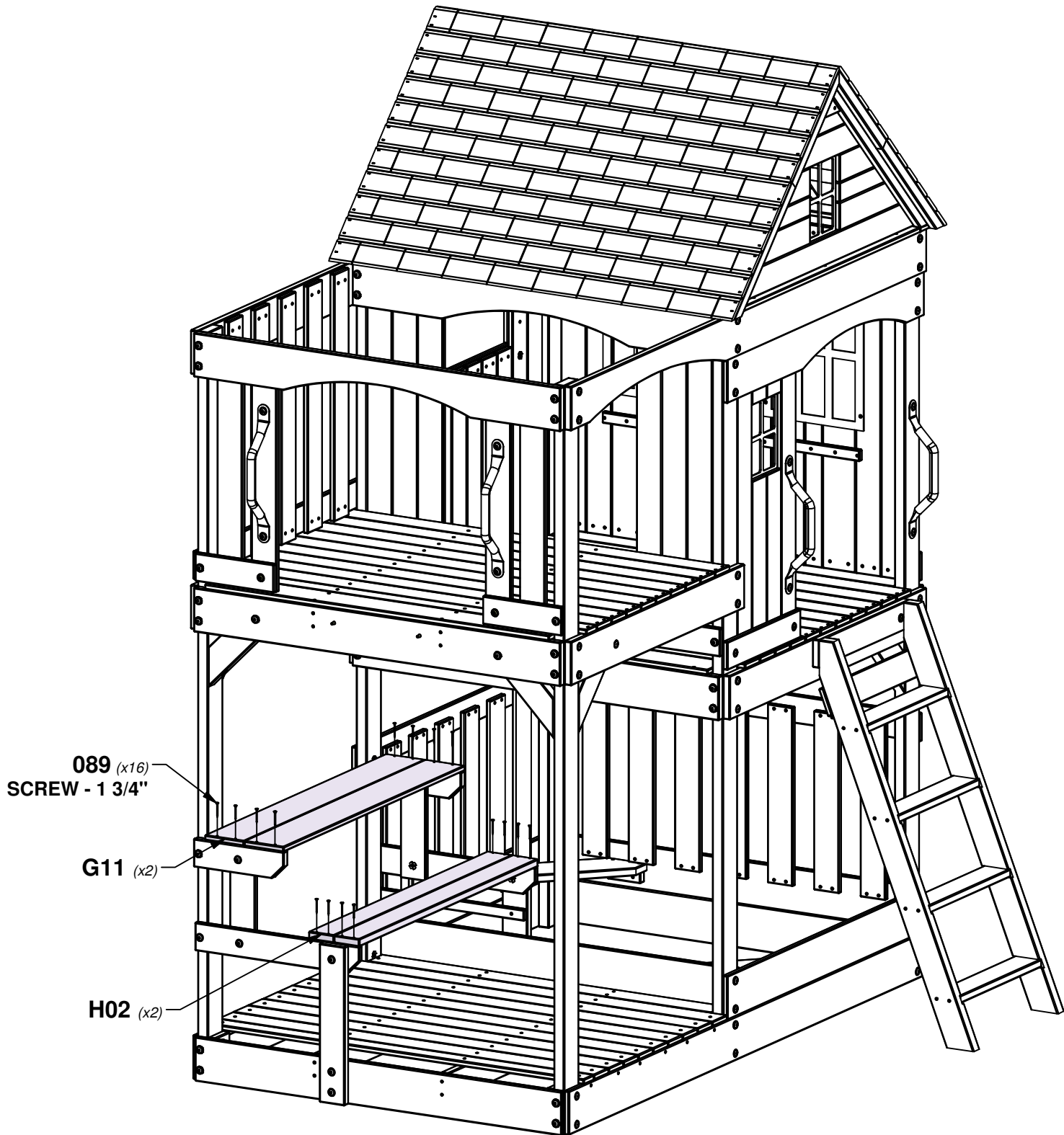



# STEP 44 - FORT ASSEMBLY

QTY	PART NUMBER	DESCRIPTION
2	H100011	BOLT WH 5/16x1 3/4
2	H100030	WASHER LOCK EXT 8x19

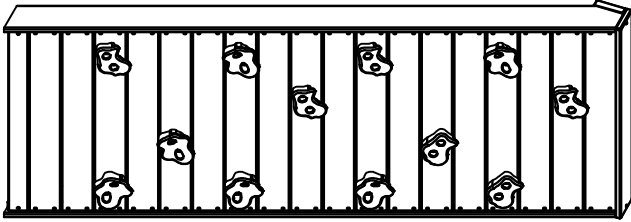

ROCKWALL ASSEMBLY

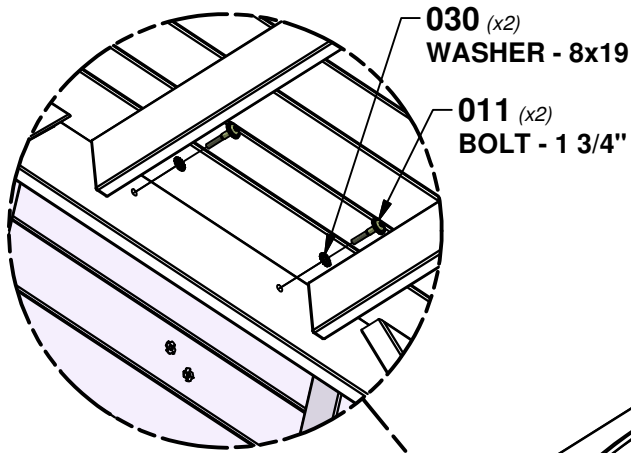

030 (x2)  
WASHER - 8x19

011 (x2)  
BOLT - 1 3/4"

ROCKWALL ASSEMBLY

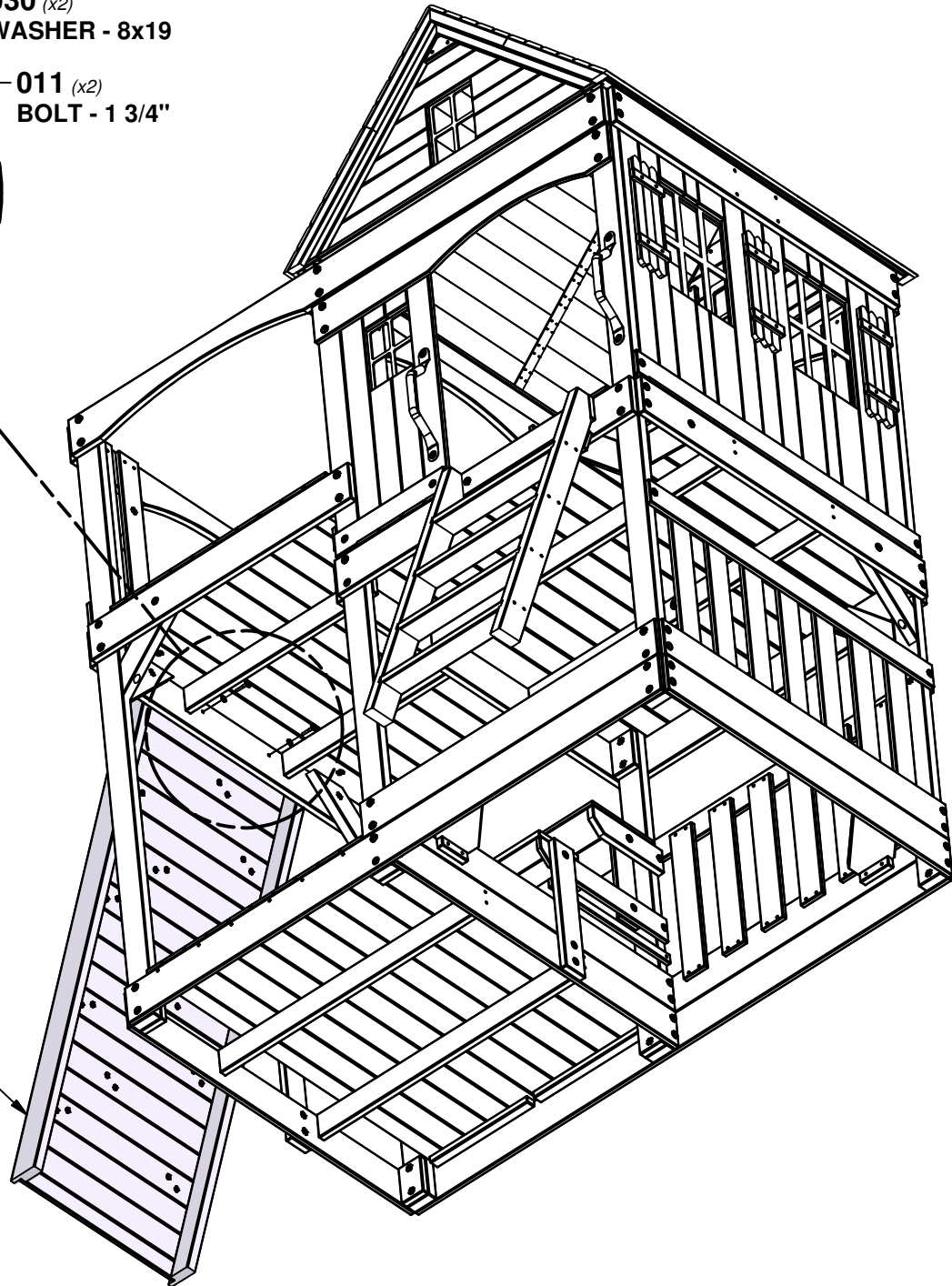

# STEP 45 - FORT ASSEMBLY

QTY	PART NUMBER	DESCRIPTION
4	H100042	BOLT HEX 5/16x1 1/4
4	H100095	WASHER SPLIT 5/16
4	H100105	WASHER FLAT 8x27

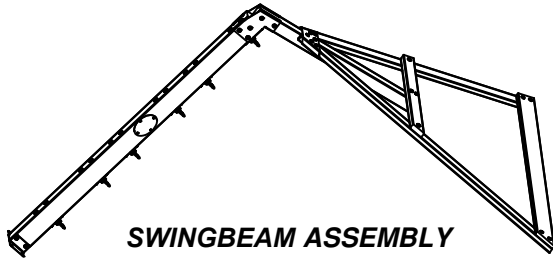

- 042 (x4)**  
BOLT HEX - 1 1/4"
- 095 (x4)**  
WASHER - 5/16"
- 105 (x4)**  
WASHER - 8x27

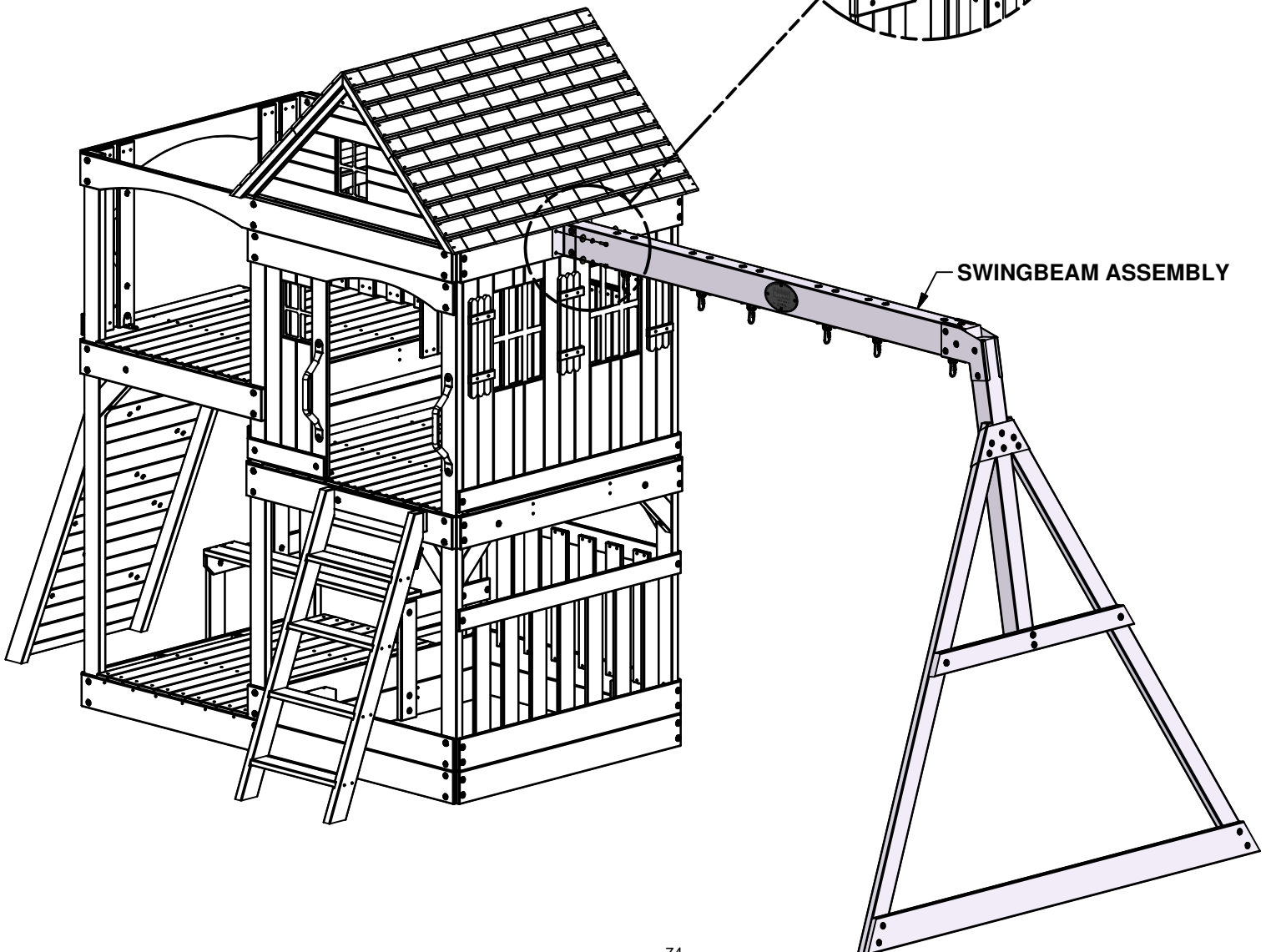
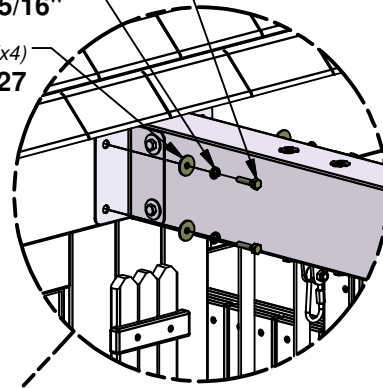



# STEP 46 - FORT ASSEMBLY

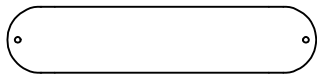

**A100027** | SWING SEAT GREEN 26"  
(x2)



**A6P00034** | TRAPEZE YELLOW  
(x1)

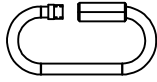

**A100069** | QUICK LINK  
(x6)

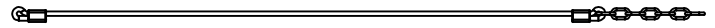

**A100183** | ROPE-CHAIN GREEN 57"  
(x4)



**A100083** | ROPE-CHAIN GREEN 33"  
(x2)

**NOTE:**  
WHEN HANGING YOUR SWINGS, IT IS REQUIRED TO ONLY TRIM AROUND THE SPECIFIC CHAIN LOOP THAT ALLOWS THE BOTTOM OF THE SWING SEAT, (WHEN SITTING ON IT) TO BE NO LOWER THAN (35CM) 13 7/8 INCHES FROM THE GROUND.

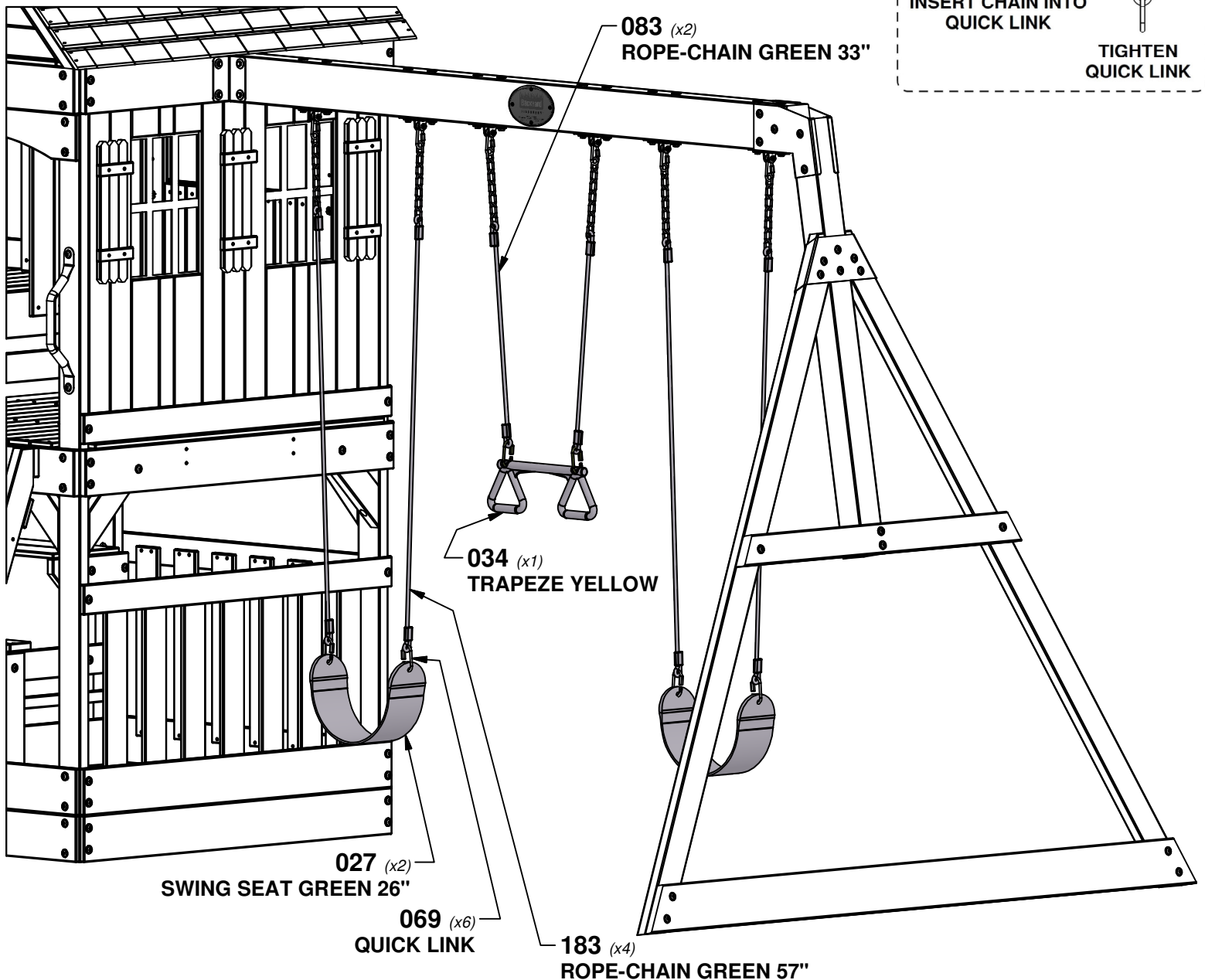
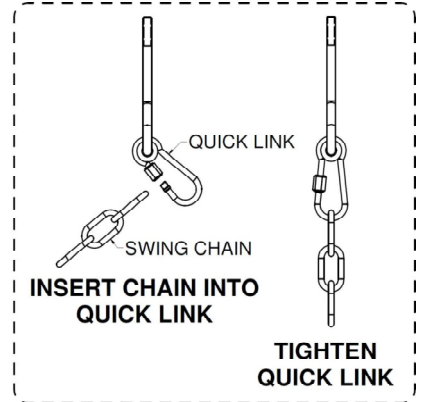

# STEP 1 - SLIDE

QTY	PART NUMBER	DESCRIPTION
3	H100074	T-NUT 5/16
3	H100115	BOLT WH 5/16x1/2



**A100035** | SLIDE BED 10' LIGHT GREEN  
(x1)

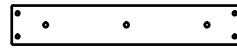

**M70** | SLIDE SUPPORT BOARD - W100935  
(x1) | 5/8"x3 3/8"x19 7/8" (16x86x505)

**NOTE:**

TAKE NOTE OF SLIDE BED SURFACE FINISH, THE DULL SIDE WILL BE TOWARDS THE GROUND. PLACE SLIDE BRACE CENTERED ON THE BOTTOM (DULL SIDE) AND 1/2" FROM THE EDGE. USE **M70** BOARD AS A TEMPLATE FOR DRILLING BOTTOM HOLE PATTERN IN SLIDE BED. USE A 5/16" DRILL BIT.

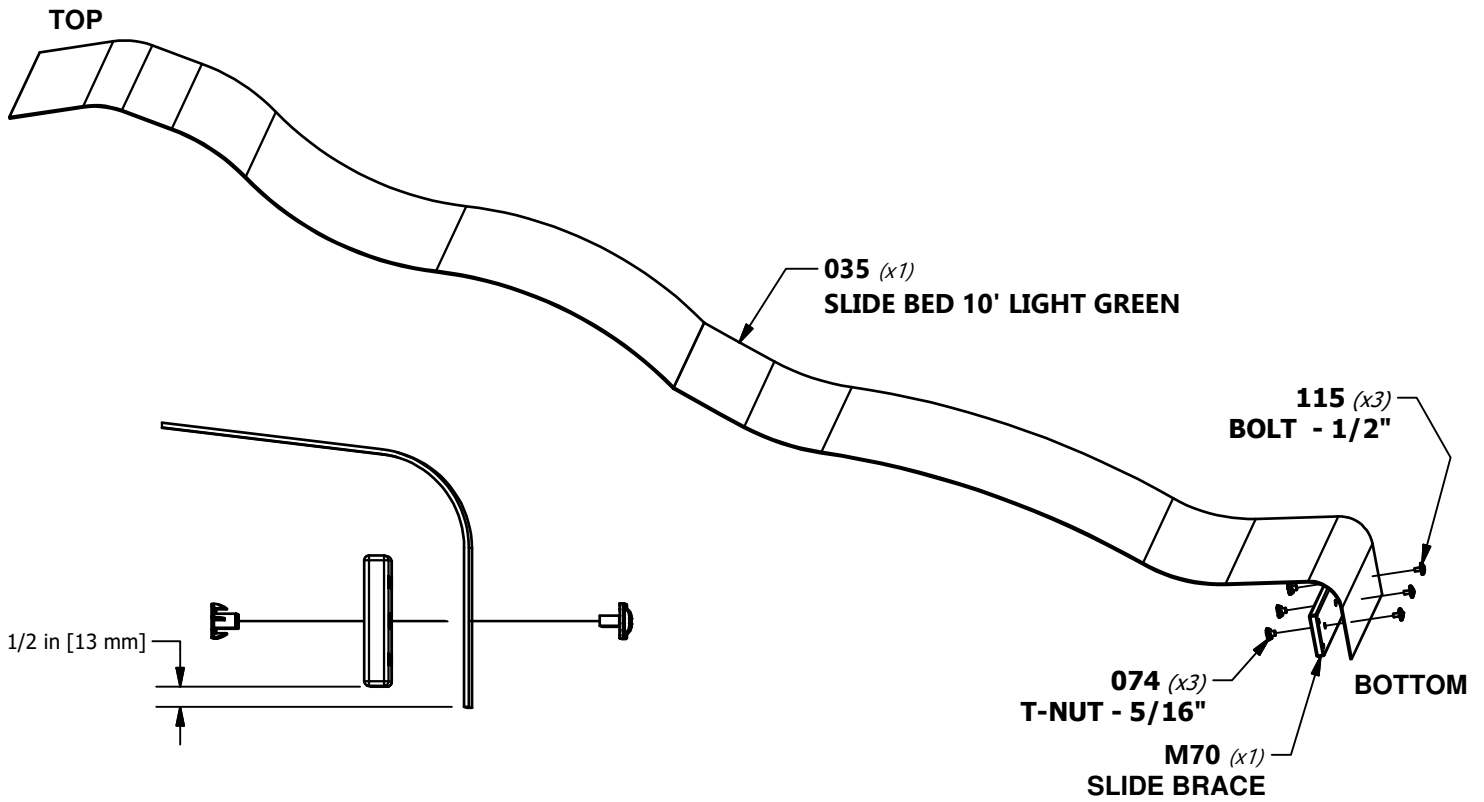

**TIP:**

PRE-BENDING THE ENDS WILL EASE ASSEMBLY. PLACING THE SLIDE BED OUT IN THE SUN MAKES IT EASIER TO BEND.

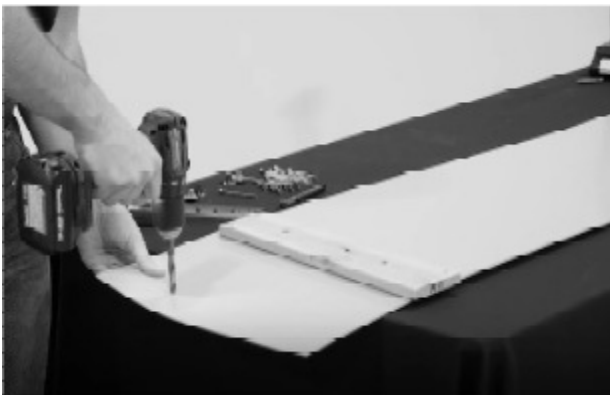

# STEP 2 - SLIDE

QTY	PART NUMBER	DESCRIPTION
8	H100006	NUT BARREL WH 5/16x1 1/2
8	H100115	BOLT WH 5/16x1/2

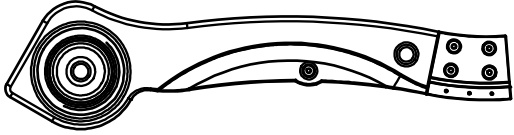

**A6P00484** | SLIDE RAIL 10' BOTTOM RIGHT GREEN  
(x1)

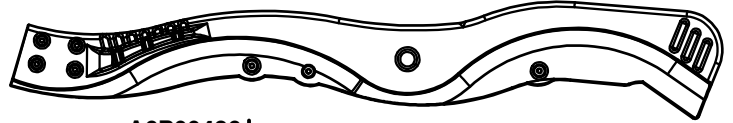

**A6P00486** | SLIDE RAIL 10' TOP RIGHT GREEN  
(x1)

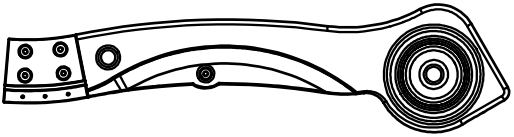

**A6P00483** | SLIDE RAIL 10' BOTTOM LEFT GREEN  
(x1)

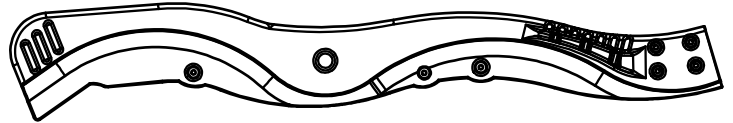

**A6P00485** | SLIDE RAIL 10' TOP LEFT GREEN  
(x1)

**NOTE:**  
REPEAT ON OTHER SIDE, MAKING  
A LEFT AND RIGHT ASSEMBLY.

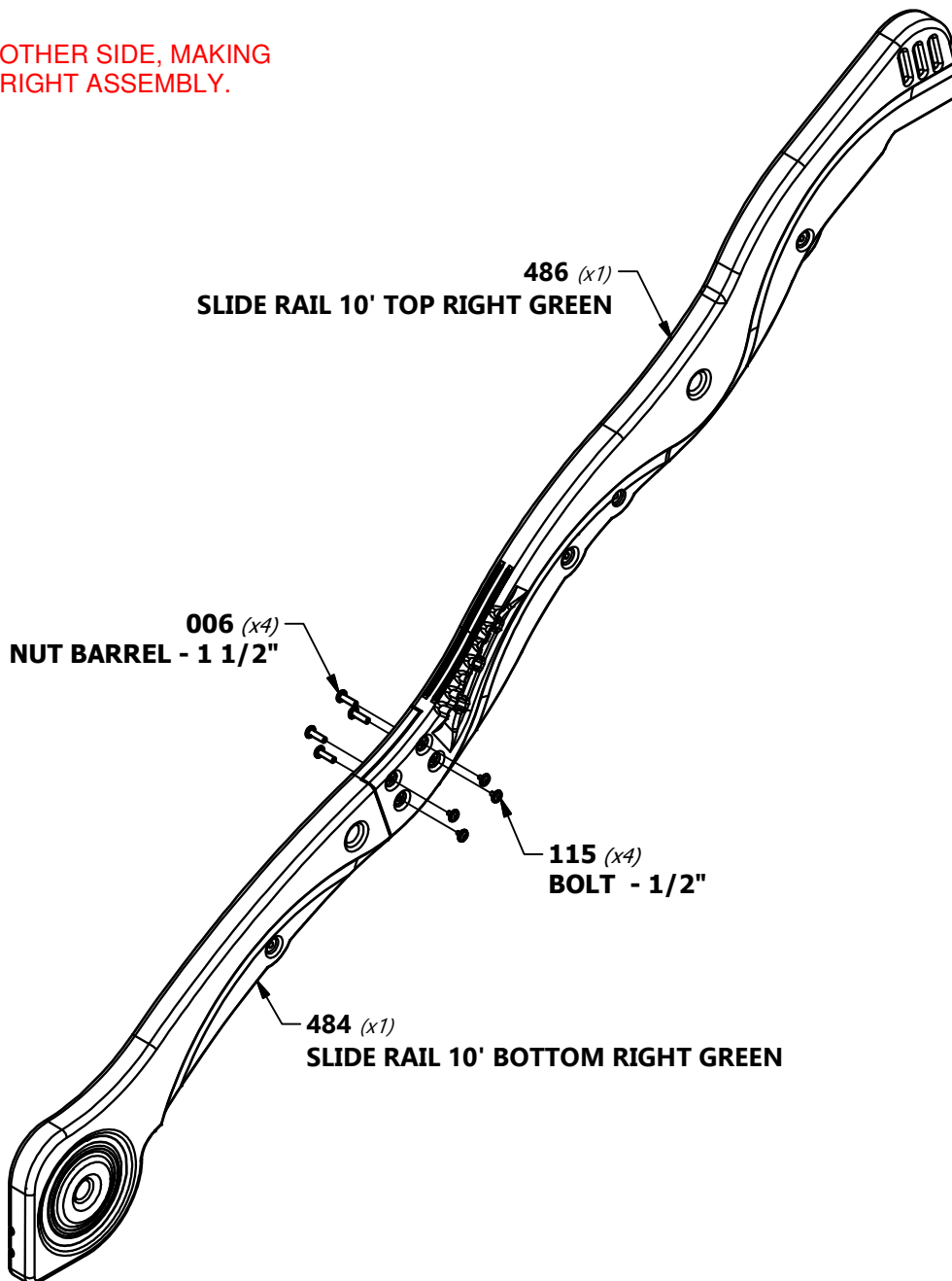

# STEP 3 - SLIDE

QTY	PART NUMBER	DESCRIPTION
4	H100009	BOLT WH 5/16x1 1/4

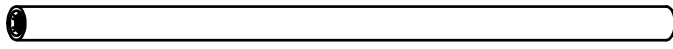

**A6P00487**  
(x4) | **SLIDE TUBE SUPPORT**

**NOTE:**  
INSERT THE (4) SLIDE SUPPORT TUBES INTO THEIR RESPECTIVE PILOT LOCATIONS (FIGURE 1).

PLACE (1) SLIDE RAIL ASSEMBLY ON A FLAT SURFACE AND BEGIN INSERTING SLIDE BED AT THE BOTTOM OF THE SLIDE RAIL (FIGURE 2). HAVE A HELPER BEND THE SLIDE BED TOWARDS THE TOP OF THE SLIDE AND INSERT THE BED INTO THE SLIDE CAVITY. MAKE SURE SLIDE BED IS INSERTED WITHIN 1/8" (3mm) OF GROOVE BOTTOM.

**TIP:**  
A HELPER IS RECOMMENDED FOR THESE FOLLOWING STEPS.

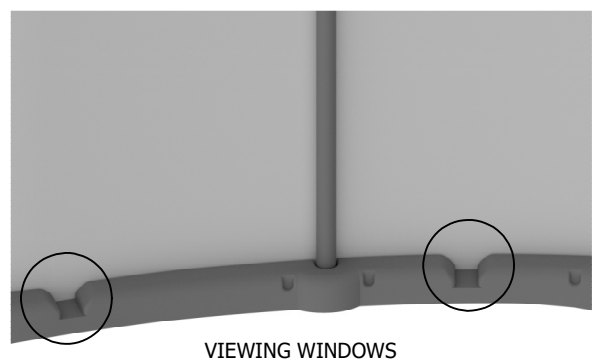
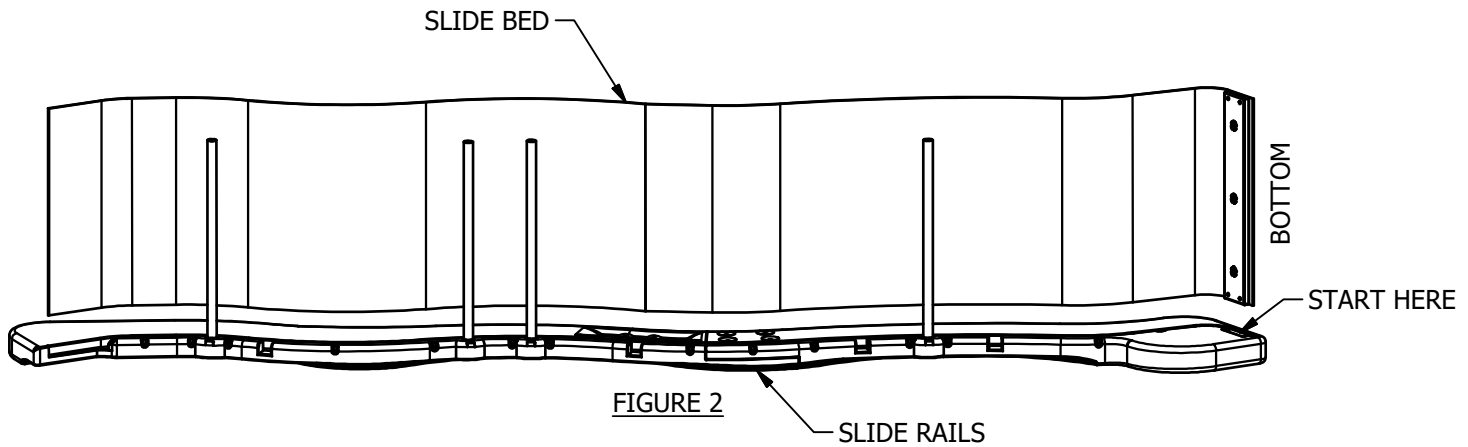
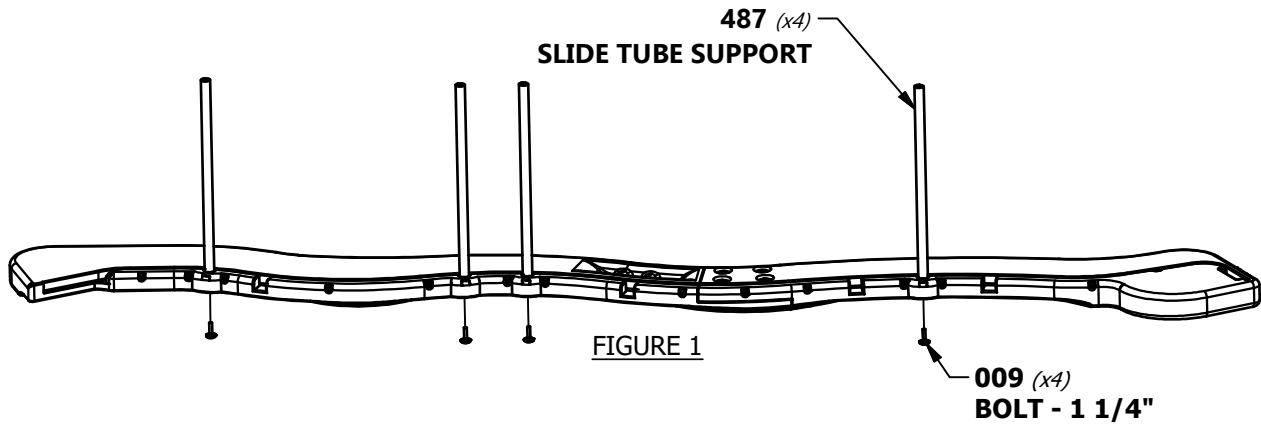

# STEP 4 - SLIDE

**NOTE:**

PLACE SECOND SLIDE RAIL ASSEMBLY OVER THE TOP OF THE SLIDE BED AND SLIDE SUPPORT TUBES. INSERT THE SLIDE BED AND SLIDE SUPPORT TUBES INTO THE SLIDE CAVITY. MAKE SURE SLIDE BED IS INSERTED WITHIN 1/8" (3mm) OF GROOVE BOTTOM.



**FAILURE TO INSERT SLIDE BED PROPERLY MAY RESULT IN INJURY OR AMPUTATION. EXPOSED SLIDE EDGES CAN BE SHARP AND BECOME A LACERATION HAZARD IF THE SLIDE IS NOT PROPERLY ASSEMBLED.**

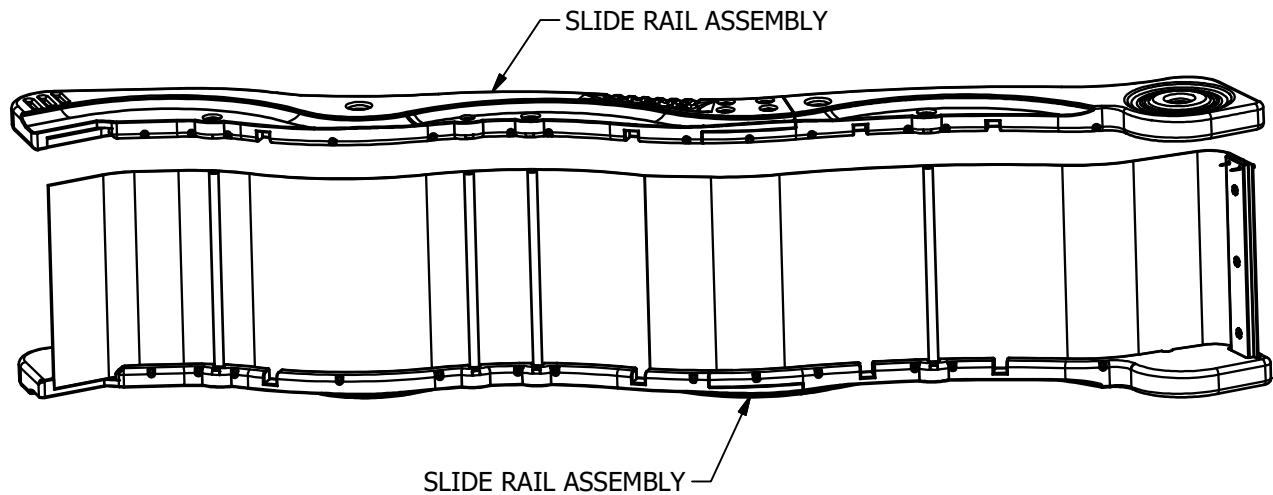

**TIP:**  
USE A RUBBER Mallet TO FULLY SEAT THE SLIDE BED INTO THE SLIDE CAVITY.

# STEP 5 - SLIDE

QTY	PART NUMBER	DESCRIPTION
4	H100009	BOLT WH 5/16x1 1/4

NOTE:  
USE 1 1/4" BOLTS TO FASTEN EACH  
SIDE OF THE SLIDE SUPPORT TUBES.

TIP:  
HAVING A HELPER HOLD THE SLIDE  
ASSEMBLY TOGETHER WHILE YOU FASTEN  
WILL MAKE IT EASIER TO ASSEMBLE.

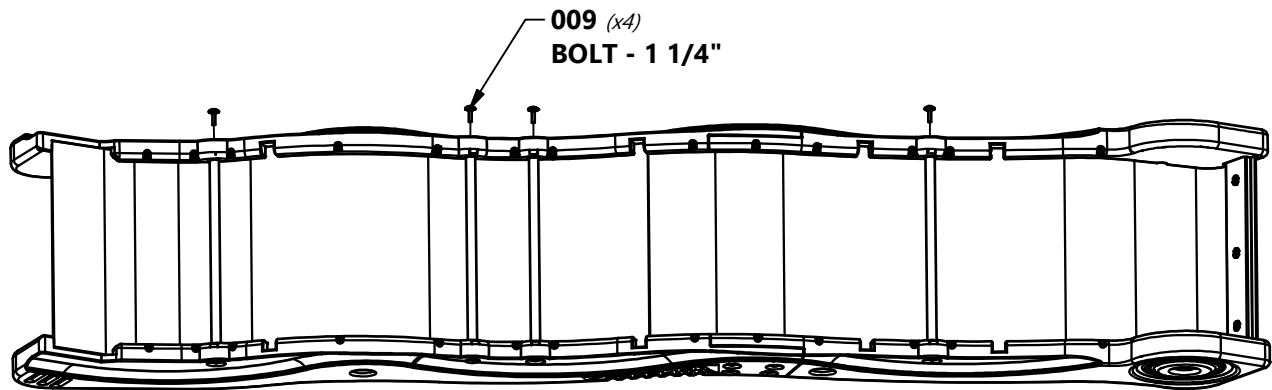

# STEP 6 - SLIDE

QTY	PART NUMBER	DESCRIPTION
30	H100090	SCREW PFH 8x2 1/2

**NOTE:**  
USING AN 1/8" DRILL BIT, DRILL PILOT HOLES IN EACH INDENTATION  
ALONG EACH SIDE RAIL. THERE SHOULD BE 15 INDENTATIONS ON  
EACH RAIL. BE SURE TO DRILL THROUGH THE SLIDE RAIL AND THE  
SLIDE BED. THEN SECURE WITH THE PROVIDED HARDWARE.

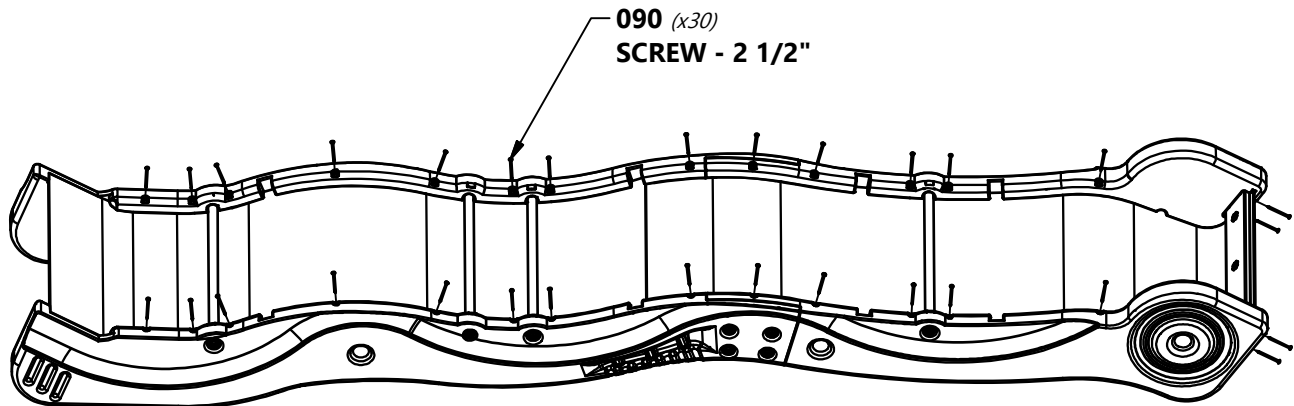

# STEP 47 - FORT ASSEMBLY

QTY	PART NUMBER	DESCRIPTION
3	H100074	T-NUT 5/16
3	H100115	BOLT WH 5/16x1/2

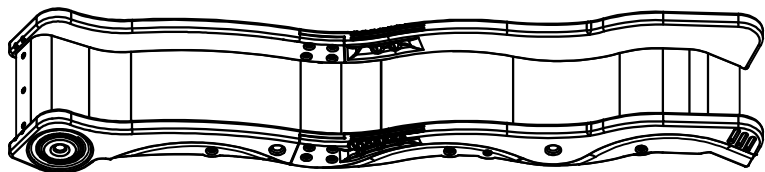

SLIDE ASSEMBLY

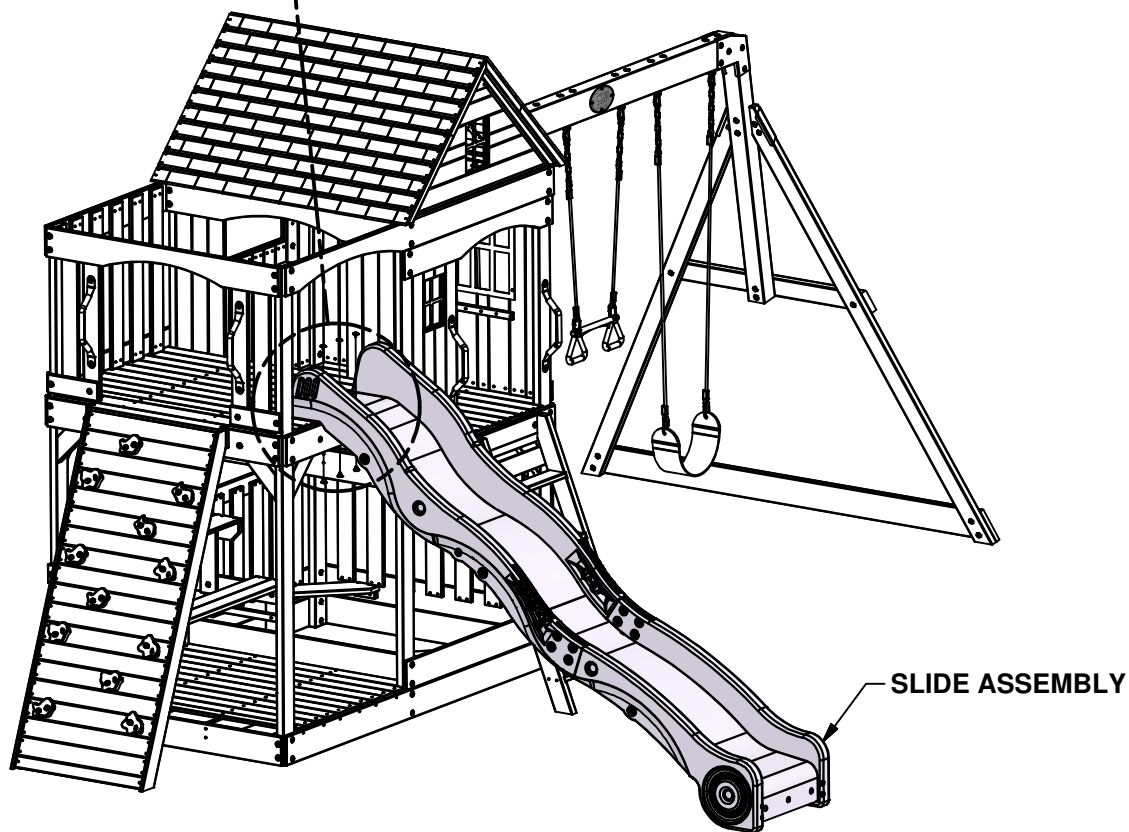
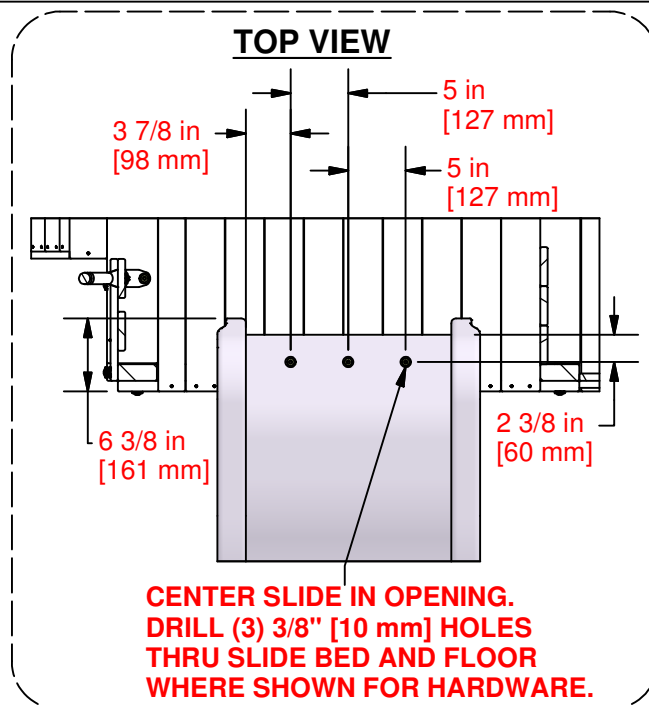
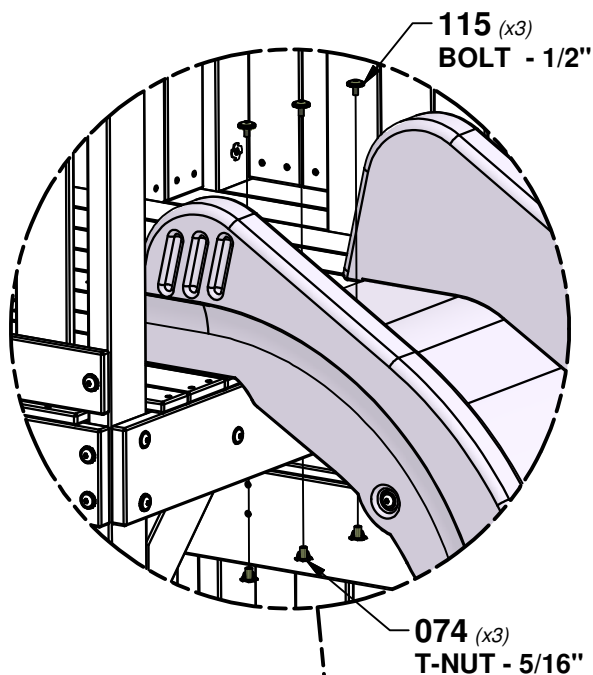



# STEP 48 - FORT ASSEMBLY

QTY	PART NUMBER	DESCRIPTION
8	H100004	NUT BARREL WH 5/16x5/8
8	H100031	WASHER LOCK EXT 12x19
2	H100008	BOLT WH 5/16x1
2	H100009	BOLT WH 5/16x1 1/4
4	H100222	BOLT WH 5/16x3/4

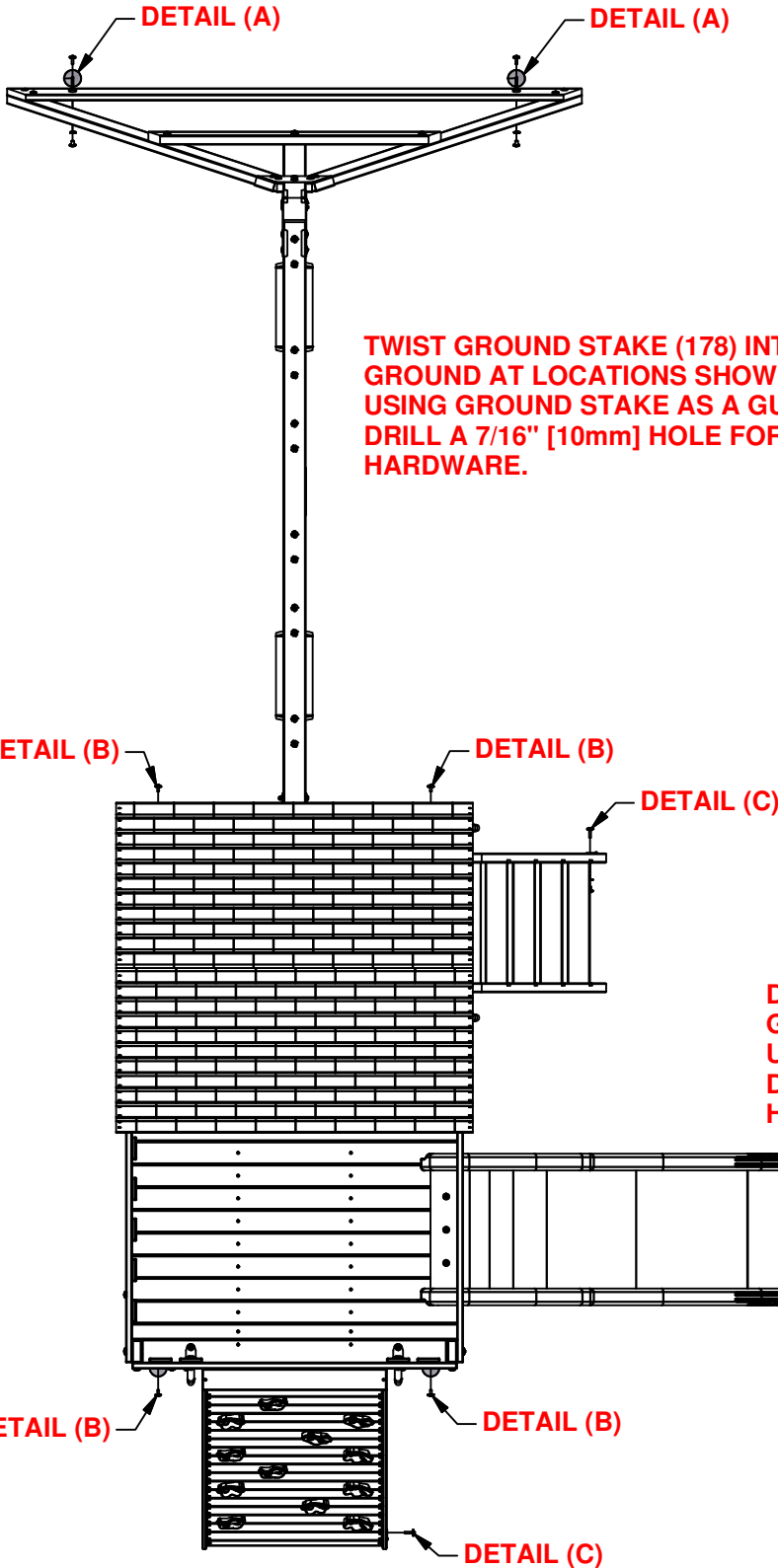

**TWIST GROUND STAKE (178) INTO GROUND AT LOCATIONS SHOWN. USING GROUND STAKE AS A GUIDE, DRILL A 7/16" [10mm] HOLE FOR HARDWARE.**

**DRIVE GROUND STAKE (527) INTO GROUND AT LOCATIONS SHOWN. USING GROUND STAKE AS A GUIDE, DRILL A 7/16" [10mm] HOLE FOR HARDWARE.**

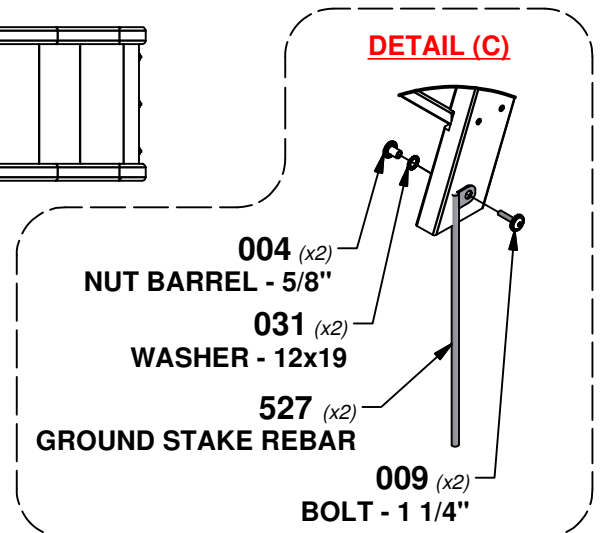
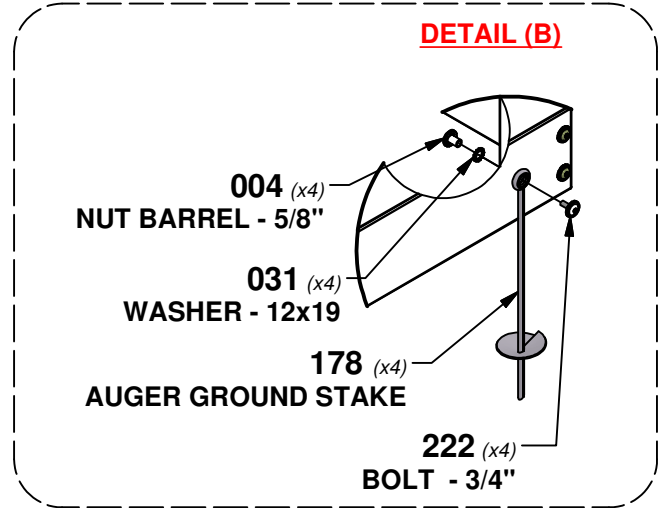
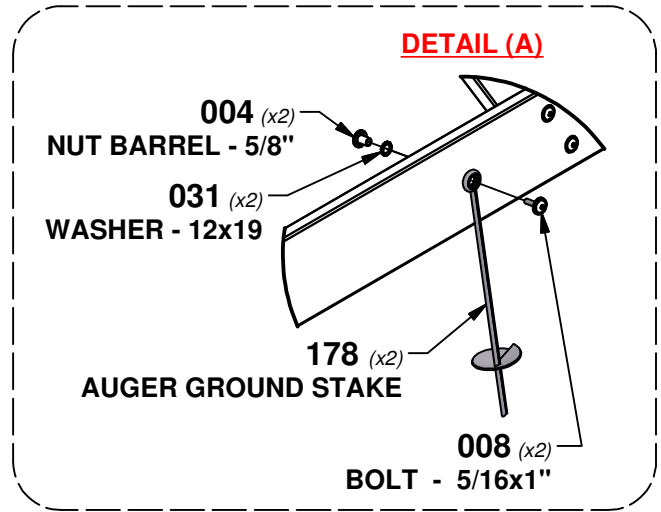

# STEP 49 - FORT ASSEMBLY

QTY	PART NUMBER	DESCRIPTION
6	H100086	SCREW PFH 8x1-1/2"



**Y01** | OUTSIDE FILLER FLOOR BOARD - W4L16087  
(x1) | 5/8"x4"x46" (16x102x1168)

