

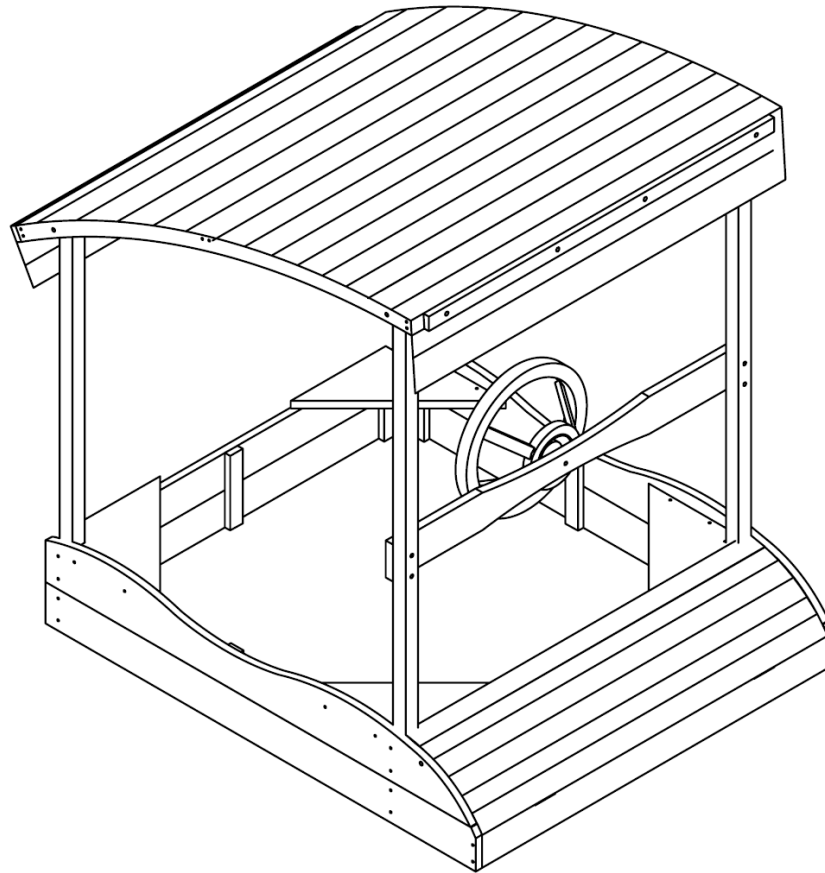

Captain Sand Pit Instructions



WARNING!
Not suitable for children
under 3 years until fully
assembled. Small parts.
Choking hazard.

Important

The owner's manual contains safety, assembly, use and maintenance instructions. The product must be assembled by an adult who has read and understand these instructions. Keep the packaging away from children and dispose of all packaging before use. It is best to keep the instructions for future reference.

For the installer and your children's safety, it is important to fully read and understand the instructions and safety hazards before commencing the assembly of the product.



Safety

- ⚠️ Only adults should assemble or disassemble this product.
- ⚠️ This product may contain sharp edges and small parts prior to assembly - product must be assembled by an adult
- ⚠️ This product is safely designed for children between the ages of 18 months to 12 years old.
- ⚠️ Adult supervision of children is required at all times when on or around this product. We advise that parents should observe and ensure that their children have the strength and skills to enjoy all the equipment safely before using them on their own.
- ⚠️ To prevent serious injury do not allow children to play on the product until it is completely assembled and installed.
- ⚠️ Children using this product should only use the product in the manner intended. i.e. do not climb on the roof
- ⚠️ Use washed playsand suitable for use in children's sandpits
- ⚠️ Always cover your sandpit when not in use to prevent unwanted animals from entering the sandpit.
- ⚠️ The sandpit should be covered when not used to prevent water from entering the sandpit.
- ⚠️ It is recommended that a large object is used to 'prop up' the cover so that rain water does not 'pool' into the centre.
- ⚠️ Please regularly check sand for impurities and any other sharp objects that may cause harm to children.

Timber

Our product was manufactured from premium timber with great care dealt in selecting, machining and treating the timber before it is sold to you.

Bear in mind that timber is a natural product and may experience changes throughout the course of its life. It may:

- Develop openings (gaps, slits, apertures, cracks) along the line of the grain. This occurs due to moisture content between internal and outer surfaces of the timber. It is totally acceptable and will not affect the integral strength, life or guarantee of the product.
- Fade as the timber reacts with sunlight. The timber should be treated with a proprietary product to act as a protective barrier (i.e. a watery repellent on an annual basis)
- Warp and distort its shape. Any distortion will be slight and will not affect the safety or enjoyment of this product.

Assembly

This product contains pre-assembled parts for easier assembly.

One adult is required for the assembly or disassembly of the product.

Do not allow children to play on the product until it is complete assembled and installed

***Make sure you place the sand lining into the bottom of the sandpit before placing sand into the sandpit.**

See below for Parts and Assembly instructions



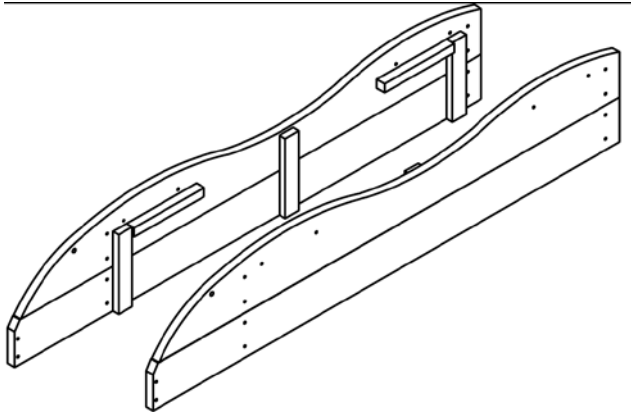

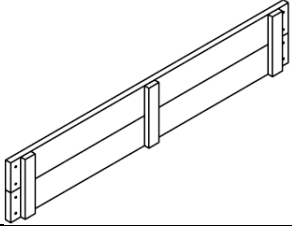
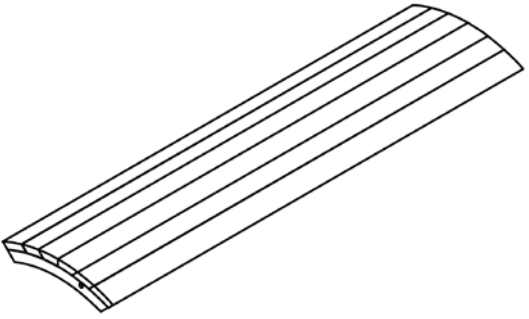
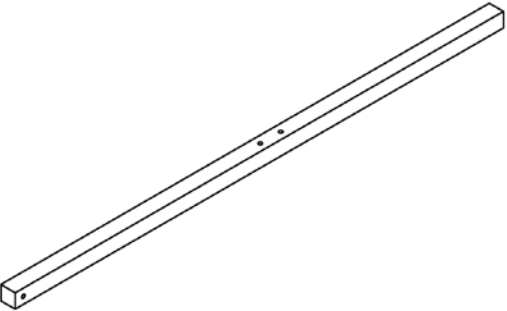
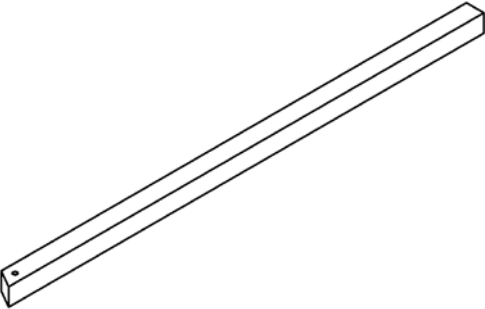
Parts

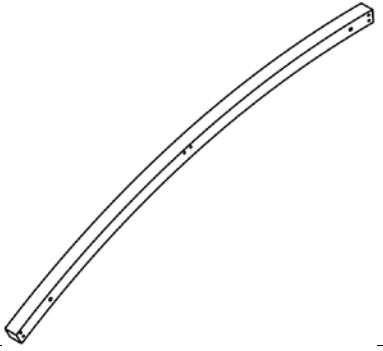
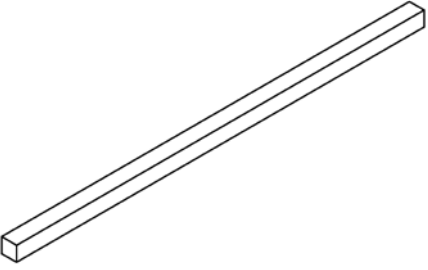
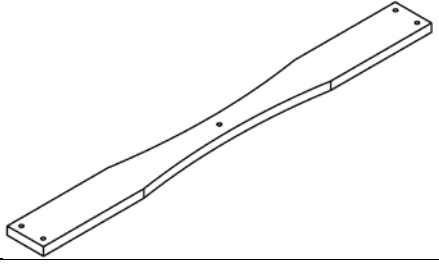
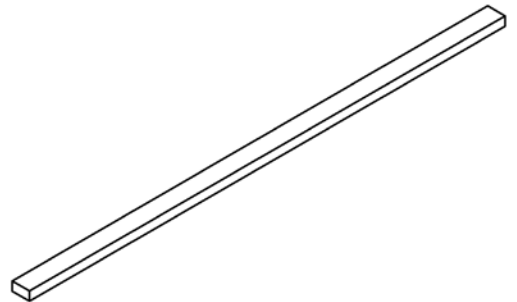
Type	Parts	Quantity
1		2pcs

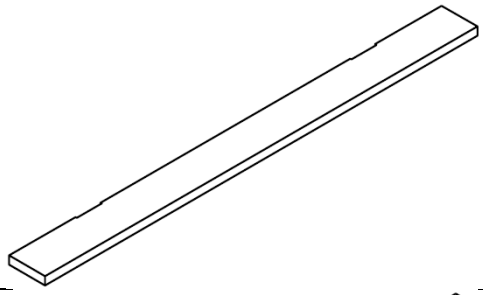
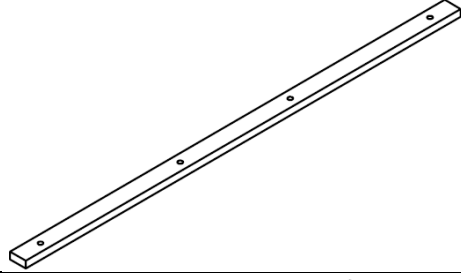
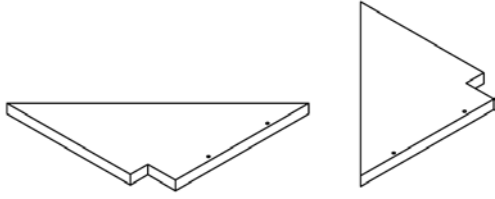
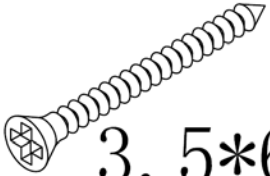
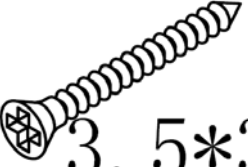
2		2pcs
3		1pc
4		2pcs
5		2pcs

6		2pcs
7		2pcs
8		1pc
9		1pc

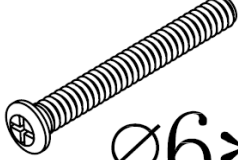
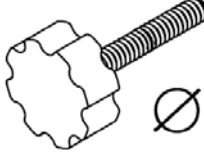
10		1pcs
11		2pcs
12		4pcs
A	 3.5*60	12pcs
B	 3.5*35	60pcs

C	 3*20	6pcs
D	 ∅6*15	8pcs
E	 ∅6*65	4pcs
F	 ∅6*50	4pcs
G	 ∅6*35	2pcs
H	 ∅8*55	1pc

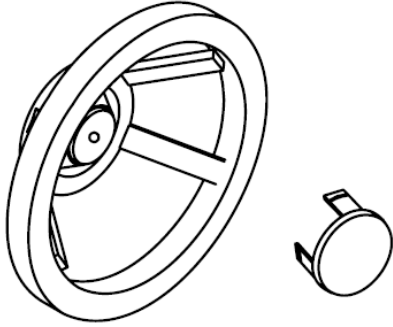
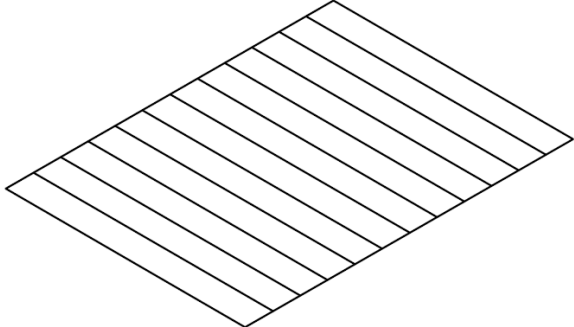
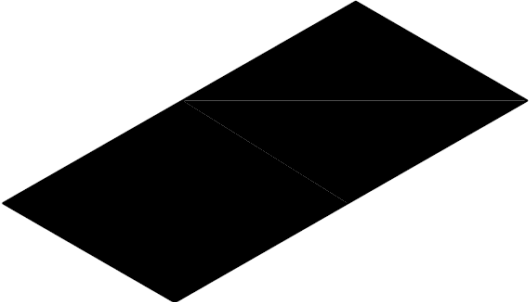
I		1pc
J		1pc
K		1pc

Assembly Instructions

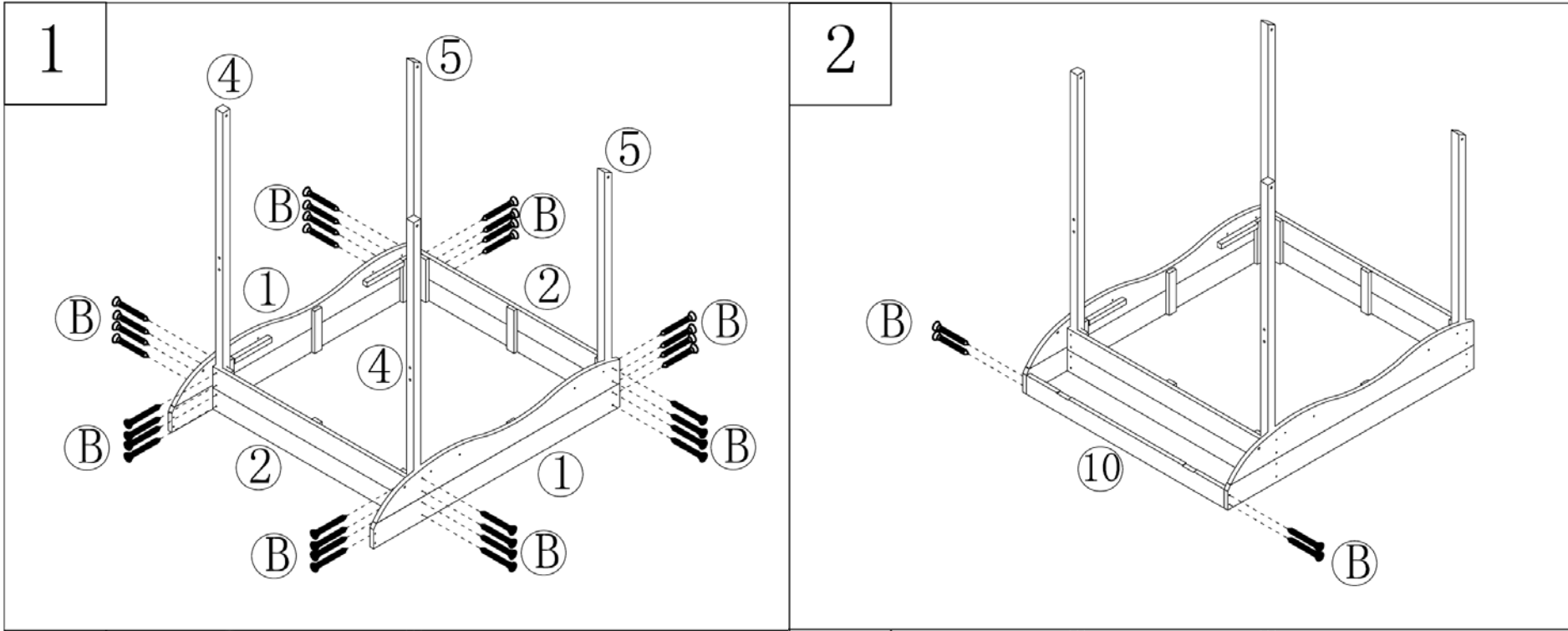

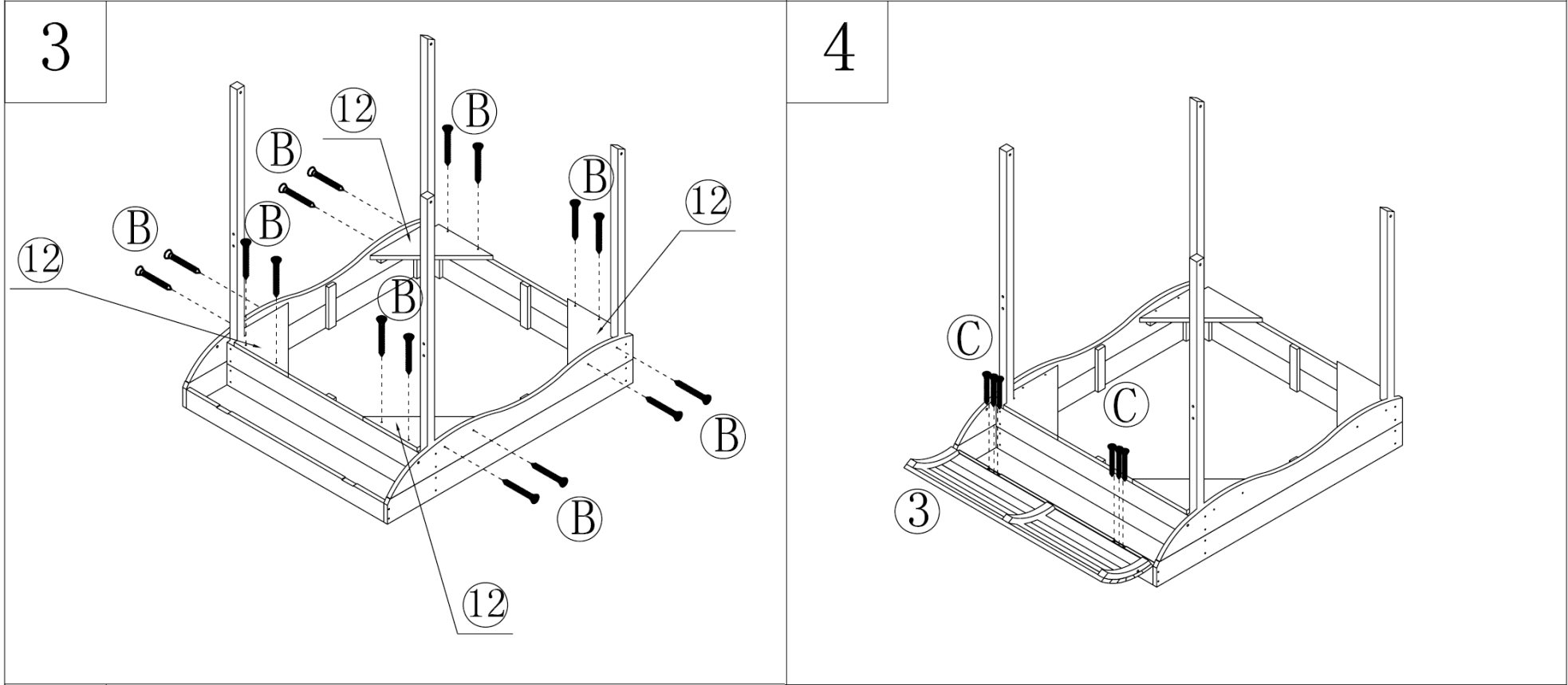

5

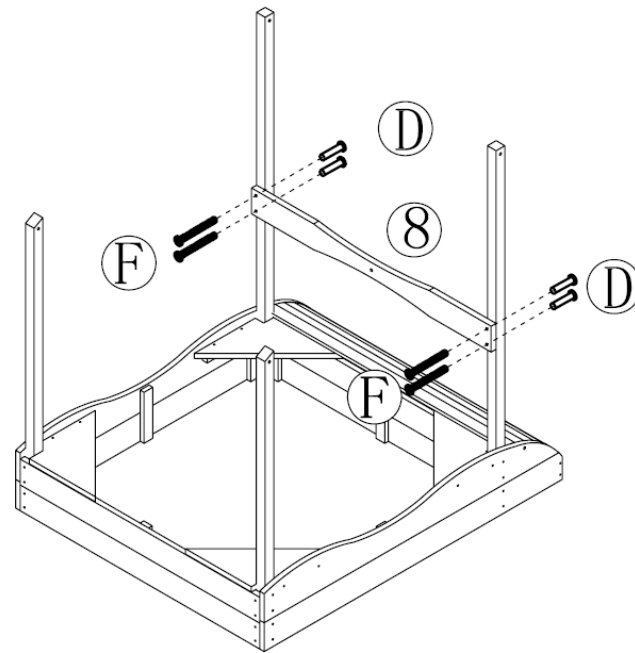

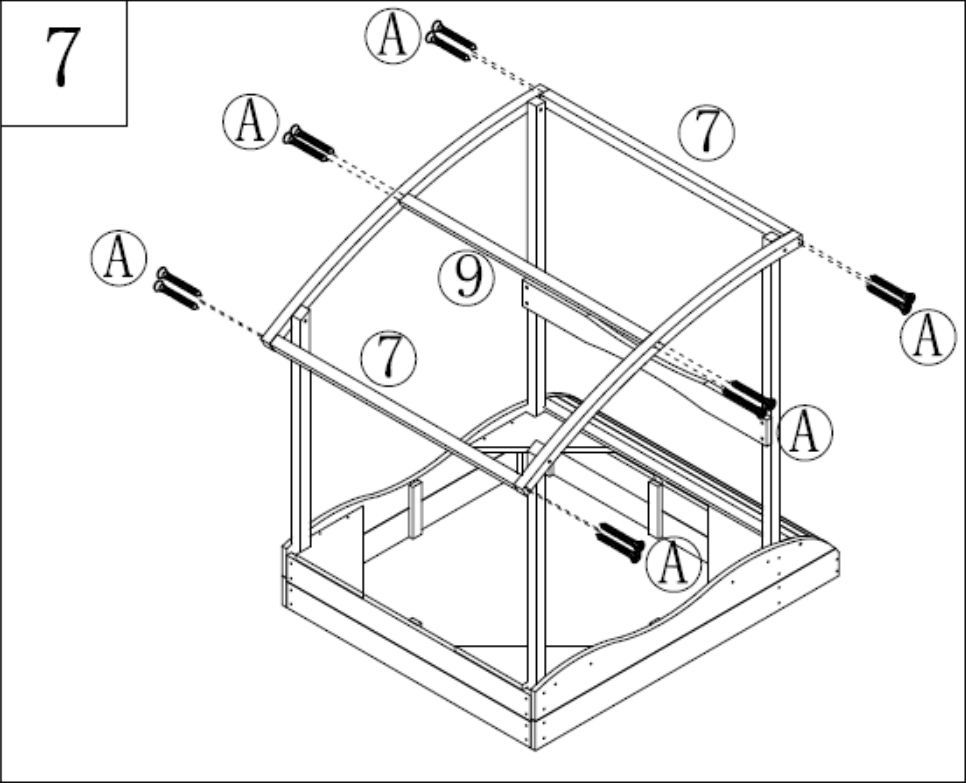
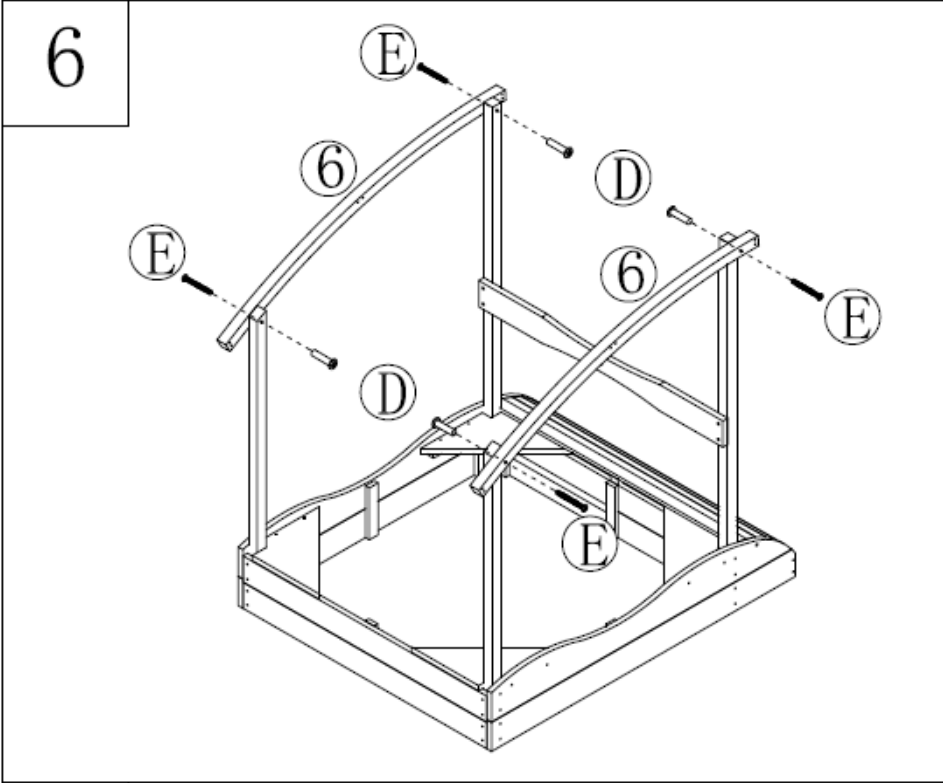

8

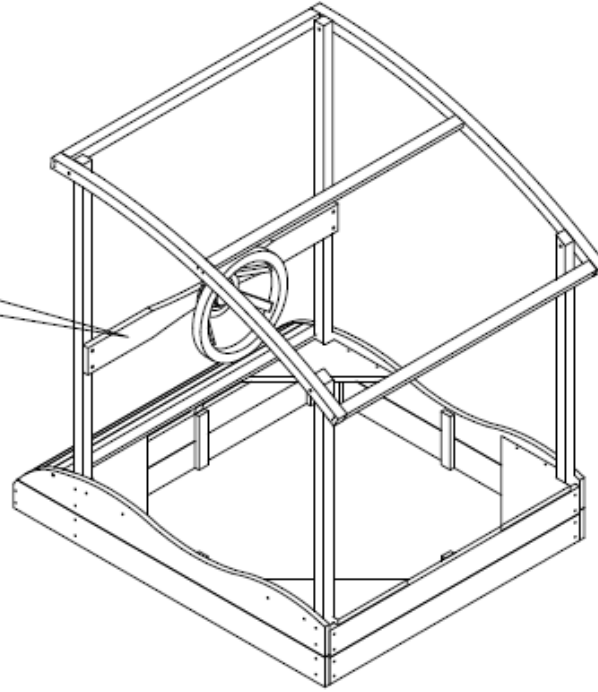
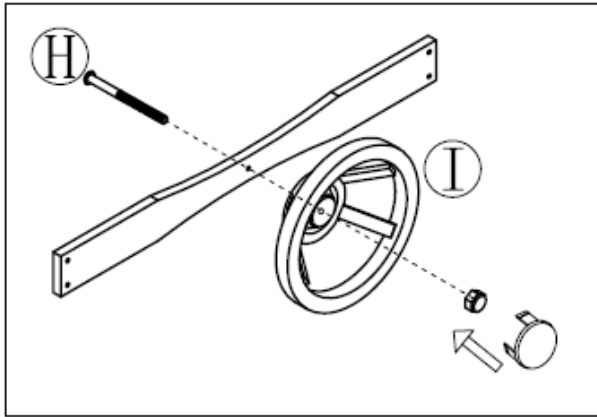

9

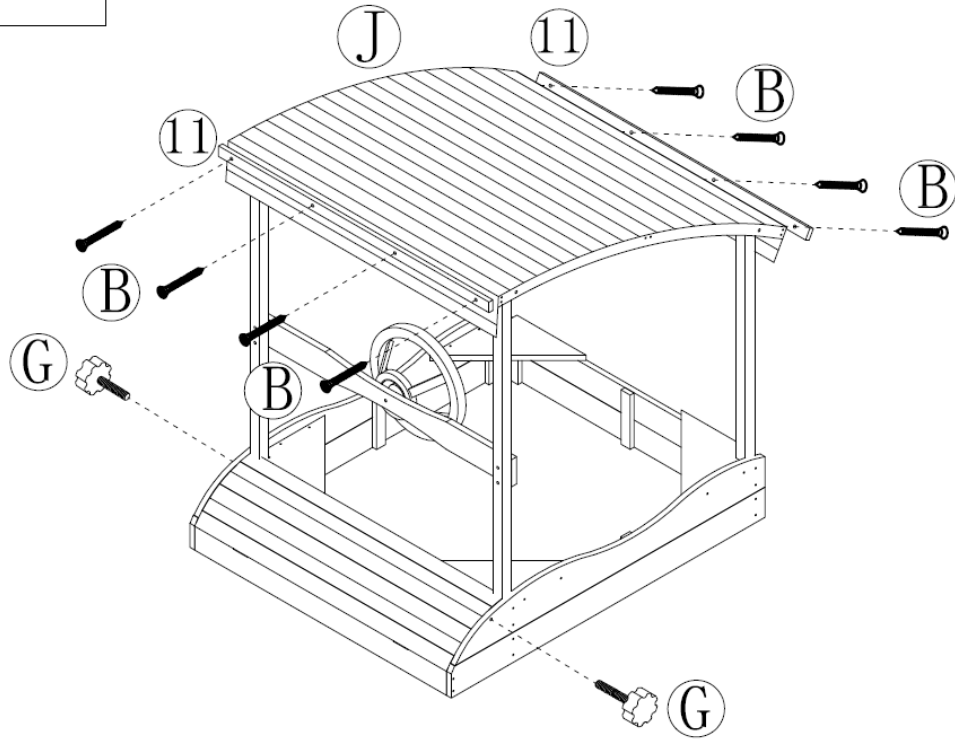

Warning! Part 3 is not intend to be open, screw G shall be fixed and never be loosen, or It may cause injuries.

10

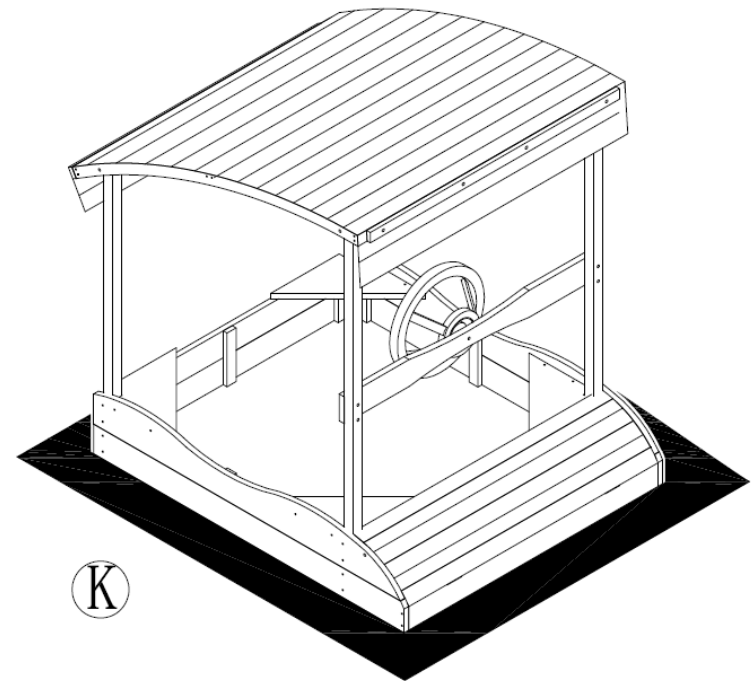

***Make sure you place the sand lining onto the bottom of the sandpit before placing sand into the sandpit.**

Care and Maintenance

We recommend regular maintenance should be conducted at the beginning of each season for your play equipment to ensure all main parts/fixings are tightly secured, well-oiled and intact to avoid injury or hazard.

We advise the following tips where applicable:

1. Tighten all hardware.
2. Lubricate all metallic moving parts
3. Check all protective coverings on bolts, pipes, edges and corners. Replace if they are loose, cracked or missing
4. Check metal parts for rust. Replace as needed
5. Prevent weathering by applying protective barriers to your timber via proprietary products to maintain its quality.
6. Attachments such as chains, ropes, swings must be regularly examined for evidence of deterioration. Replace any attachments if there are signs of deterioration.

Warranty

AUSTRALIAN CONSUMER LAW

Many of our products come with a guarantee or warranty from the manufacturer. In addition, they come with guarantees that cannot be excluded under the Australian Consumer law. You are entitled to a replacement or refund for a major failure and compensation for any other reasonably foreseeable loss or damage.

You are entitled to have the goods repaired or replaced if the goods fail to be of acceptable quality and the failure does not amount to a major failure. Full details of your consumer rights may be found at www.consumerlaw.gov.au

Please visit our website to view our full warranty terms and conditions:

<http://www.lifespankids.com.au/Warranty-Policy-Kids>

Contact us

Please visit our website at: www.lifespankids.com.au

For all technical issues: support@lifespanfitness.com.au

This manual may be subject to change. Please view our website www.lifespankids.com.au for the most recent version of this manual

