



JUNIOR HOPPER TRAMPOLINE

Assembly, Installation, Care,
Maintenance, and Usage Instructions



DO NOT ALLOW
MORE THAN ONE
PERSON ON THE
TRAMPOLINE AT A
TIME.



WARNING

**YOU MUST THOROUGHLY READ AND UNDERSTAND INSTRUCTIONS IN THIS MANUAL BEFORE ASSEMBLING AND USING THIS TRAMPOLINE.
SAVE THIS MANUAL FOR FUTURE REFERENCE.
MAXIMUM WEIGHT OF THE USER SHOULD NOT EXCEED 45KGS.
DO NOT ALLOW MORE THAN ONE PERSON ON THE TRAMPOLINE AT A TIME.
DO NOT ALLOW YOUNG CHILDREN TO USE UNLESS SUPERVISED BY AN ADULT.**

For your safety and convenience it is recommended no less than 2 persons participate in the assembly of this product.



WARNING

MAXIMUM WEIGHT OF THE USER SHOULD NOT EXCEED 45KGS.



HINT!

ASSEMBLY AND MOVING HINTS

Select a location where you want the trampoline permanently prior to assembly. Do not pick up the frame more than 5 centimetres off the ground, picking it up too high can cause the frame to warp.

If the frame does warp, put the trampoline down, press down on the part that is warped. The tension of the springs will flatten the frame.

MOVING THE TRAMPOLINE



WARNING

If you need to move the trampoline, two or three people are required. All connector points should be wrapped and secured with weather resistant tape, such as duct tape. This will keep the frame intact during the move and prevent the connector points from dislocating and separating. When moving, lift the trampoline slightly off the ground and keep it horizontal to the ground. For any type of other move, you should disassemble the trampoline.



WARNING

We strongly recommend you do not use the trampoline without an ASTM standard enclosure. If you find the trampoline is being used without an enclosure, stop the user and immediately purchase and install the enclosure. You must make sure that there are no walls, posts, fences, rocks, or any hard or sharp objects within 4.5 metres of the trampoline. Also, the trampoline must not sit on concrete or any hard surface.

ASSEMBLY AND INSTALLATION INSTRUCTION



WARNING

The trampoline enclosure is only to be used as an enclosure for a trampoline and the trampoline must be of the appropriate size as covered by specific enclosure.

PLEASE READ THE ENTIRE INSTRUCTION BOOKLET BEFORE YOU ASSEMBLE OR USE THIS TRAMPOLINE AND TRAMPOLINE ENCLOSURE

FOR QUICKER, EASIER AND SAFER ASSEMBLY, MAKE CERTAIN TO FOLLOW INSTRUCTIONS FOR SPRING PLACEMENT.

INSTALLATION OF THE TRAMPOLINE AND TRAMPOLINE ENCLOSURE

MAKE SURE THE ASSEMBLED TRAMPOLINE IS ON LEVEL GROUND

- ✧ Misuse and abuse of this trampoline is dangerous and can cause serious injury
- ✧ Trampolines, being a rebounding device, propel the performer to unaccustomed heights and into a variety of body movements.
- ✧ Always inspect the trampoline before each use for mat wear, loose or missing parts.
- ✧ Proper assembly, care and maintenance of product, safety tips, warnings, and proper techniques in jumping and bouncing are all included in this manual. All users and supervisors must read and familiarize themselves with these instructions. Anybody who chooses to use this trampoline must be aware of their own limitations in regards to performing various jumps and bounces with this trampoline.



WARNING



NO MORE THAN ONE PERSON AT A TIME ON THE TRAMPOLINE! MULTIPLE JUMPERS INCREASE THE RISK OF INJURY SUCH AS BROKEN HEAD, NECK, LEG, OR BACK.



PARALYSIS OR DEATH CAN RESULT IF YOU LAND ON YOUR HEAD OR NECK! DO NOT PERFORM SOMERSAULTS (FLIPS) AS THIS WILL INCREASE YOUR CHANCES OF LANDING ON YOUR HEAD OR NECK!

ALWAYS CONSULT A PHYSICIAN BEFORE PERFORMING ANY KIND OF PHYSICAL ACTIVITY

- Adequate overhead clearance is essential. A minimum of **7.3 metres** from ground level is recommended. Maintain a clear space on all sides of the trampoline.
- Place the trampoline and trampoline enclosure on a level surface before use. Illumination may be required for shady area. Use the trampoline and trampoline enclosure in a well-lighted area. Artificial illumination may be required for indoor or shady areas.
- Secure the trampoline and trampoline enclosure against unauthorized and unsupervised use.
- Remove any obstructions from beneath the trampoline and trampoline enclosure.
- The trampoline enclosure is only to be used as an enclosure for a trampoline of a size for which the enclosure is designed.
- The owner and supervisors of the trampoline are responsible to make all users aware of practices specified in the use instructions.
- Do not allow more than one person on the trampoline. Use by more than one person at the same time can result in serious injury.
- For additional information concerning the trampoline equipment, contact the manufacturer.

WARNING

- Recommended for children between 3-10 years of age. Max. weight limit : 45kgs
- Read all instructions before using the trampoline and trampoline enclosure, warnings and instructions for the care, maintenance, and use of this trampoline are included to promote safe, enjoyable use of this equipment.
- Use trampoline and trampoline enclosure only with mature, knowledgeable supervision.
- Learn fundamental bounces and body positions thoroughly.
- While keeping the head erect, focus eyes on the trampoline toward the perimeter.
- Bounce in the center of the mat.
- Keep objects away which could interfere with the performer.
- For equipment information, contact the manufacturer.
- For skill training information, contact a trainer certification organization.
- Do not use when trampoline is wet or in windy conditions.

TRAMPOLINE PLACEMENT

The minimum overhead clearance required is **7.3 metres**. For safe use of the trampoline, please be aware of the following when selecting a place for your trampoline:

- Make sure it is placed on a level surface.
- The area is well-lit. Artificial illumination maybe required for shady areas.
- Remove any obstructions from beneath the trampoline.
- When not in use, the trampoline should be secured against unauthorized use.
- The surface of the jumping mat should be dry. Do not jump on a wet mat.
- Wind or air movement should be calm and gentle. Do not use trampoline in gusty or severe wind.
- The person in charge and responsible for use of the trampoline should make users aware of practices specified in this manual. Person in charge should be a qualified adult. This person should always be present when trampoline is in use.
- Do not place trampoline on slippery surface.

USAGE INSTRUCTIONS



WARNING

- DO NOT attempt or allow somersaults. Landing on the head or neck can cause serious injury, paralysis, or death, even when landing in the middle of the bed.
- Do not allow more than one person inside the trampoline enclosure. Use by more than one person at the same time can result in serious injuries.
- Use trampoline and trampoline enclosure only with mature, knowledgeable supervision.
- Inspect the trampoline and trampoline enclosure before each use. Make sure the frame padding, barrier and the enclosure support (frame) padding is correctly and securely positioned. Replace any worn, defective or missing parts.
- Climb on and off the trampoline, it is a dangerous practice to jump from the trampoline to the floor or ground when dismounting, or to jump onto the trampoline when mounting. Do not use the trampoline as a springboard to other objects.
- Stop bouncing by flexing knees as feet come in contact with the trampoline bed. Learn this skill before attempting others.
- Learn fundamental bounces and body positions thoroughly before trying more advanced skills. A variety of trampoline activities can be carried out by performing the basic fundamentals in various series and combinations, performing one fundamental after another, with or without feet bounces between them.
- Avoid bouncing too high. Stay low until bounce control and repeated landing in the center of the trampoline can be accomplished. Control is more important than height.
- While keeping the head erect, focus eyes on the trampoline toward the perimeter. This will help control bounce.
- Avoid bouncing when tired. Keep turns short.
- Properly secure the trampoline when not in use. Protect it against unauthorized use. If a trampoline ladder is used, the supervisor should remove it from the trampoline when leaving the area to prevent unsupervised access by children under 6 years of age.
- Keep objects away which could interfere with the performer. Maintain a clear area around the trampoline.
- Do not use the trampoline while under the influence of alcohol or drugs.
- For further information or additional instruction materials on skill training, contact a competent trampoline instructor.
- Bounce only when the surface of the bed is dry. Wind or air movement should be calm and gentle. The trampoline must not be used in gusty or severe winds.
- Users may become entangled in or strangled by loose cords or in gaps between trampoline and enclosure.
- Keep enclosure tightly fastened to the trampoline. Failure to properly assemble and maintain a tight, secure trampoline/enclosure boundary may result in serious injury, strangulation, or death.
- Do not attempt to jump over the enclosure netting (barrier).
- Do not intentionally rebound off the enclosure netting (barrier).
- Do not hang from, kick, cut or climb on the enclosure netting (barrier).
- Do not attempt to crawl under the barrier.
- Wear clothing free of drawstrings, hooks, loops or anything that could get caught in the barrier.
- Do not attach anything to the barrier that is not a manufacturer-approved accessory or part of the enclosure system.
- Enter and exit the enclosure only at the enclosure door or barrier opening designated for that purpose.
- Read all instructions before using the trampoline and trampoline enclosure. Warnings and instructions for the care, maintenance, and use of this trampoline and trampoline enclosure are included to promote safe, enjoyable use of this equipment.

WARNING

- Initially, you should get accustomed to the feel and bounce of the trampoline. The focus must be on the fundamentals of your body position and you should practice each bounce (the basic bounces) until you can do each skill with ease and control.
- To break a bounce, all you need to do is flex your knees sharply before they come in contact with the mat of the trampoline. This technique should be practiced while you are learning each of the basic bounces. The skill of braking should be used whenever you lose balance or control of your jump.
- Always learn the simplest bounce first and be consistent with the control of your bounce before moving on to more difficult and advanced bounces. A controlled bounce is one when your take off point and landing point is the same spot on the mat. If you move up to the next bounce without first mastering the previous, you increase your chances of getting injured
- Do not bounce on the trampoline for extended periods of time because fatigue can increase your chance of injury. Bounce for a brief period of time and then allow others to join in on the fun! Never have more than one person bouncing on the trampoline.
- Jumpers should wear T-shirt, shorts or sweats, and regulation gymnastics shoes, heavy socks, or be barefoot. If you are just beginning, you may want to wear long sleeve shirts and pants to protect against scrapes and abrasions until you master correct landing positions and form. Do not wear hard sole shoes, such as tennis shoes on the trampoline, as this will cause excessive wear on the mat material. Jumpers should remove all sharp objects from their person prior to using the trampoline.
- You should always mount and dismount properly in order to avoid injury. To mount properly, you should place your hand on the frame and either step or roll up onto the frame, over the springs, and onto the trampoline mat. You should always remember to place your hands onto the frame while mounting or dismounting. Do not step directly onto the frame pad or grasp the frame pad. To dismount properly, move over to the side of the trampoline and place your hand onto the frame as a support and step from the mat to the ground. Smaller children should be assisted when mounting and dismounting the trampoline.
- Do not bounce recklessly on the trampoline since this will increase your chances of getting injured. The key to safety and having fun on the trampoline is control and mastering the various bounces. Never try to out-bounce another bouncer in terms of height! Never use the trampoline and trampoline enclosure alone without supervision.

TRAMPOLINE SAFETY INSTRUCTIONS

Mounting and Dismounting:

Be very careful when getting on and off the trampoline. DO NOT mount the trampoline by grabbing the safety pad, stepping onto the springs, or by jumping onto the mat of the trampoline from any object (i.e. a deck, roof, or ladder). This will increase your chances of getting injured! DO NOT dismount by jumping off the trampoline and landing on the ground, regardless of the makeup of the ground. If small children are playing on the trampoline, they may need help dismounting.

Use of Alcohol and Drugs:

DO NOT consume any alcohol or drugs when using this trampoline! This will increase your chances of getting injured since these foreign substances impair your judgment, reaction time, and overall physical coordination.

Multiple Jumpers:

Multiple jumpers (more than one person on the trampoline at any one time), increase the chance of getting injured. Injuries could occur when you fly off the trampoline, lose control, collide with the other jumper(s), or land on the springs. Generally, the lightest person on the trampoline will get injured. No more than one person at a time on the trampoline.

Striking the Frame or Springs:

When playing on the trampoline, STAY in the center of the mat. This will reduce your risk of getting injured by landing on the frame or springs. Always keep the safety pad covering the frame of the trampoline. DO NOT jump or step onto the safety pad directly since it was not intended to support the weight of a person.

Loss of Control:

DO NOT try difficult maneuvers, or any maneuvers until you have mastered the previous maneuver, or if you are just learning how to jump on a trampoline. If you do, you will increase your risk of getting injured by landing on the frame, springs, or off the trampoline completely because you might lose control of your jump. A controlled jump is considered landing on the same spot that you took off from. If you do lose control when you are jumping on the trampoline, bend your knees sharply when you land and this will allow you to regain control and stop your jump.

Somersaults (Flips):

DO NOT PERFORM somersaults of any type (backwards or forwards) on this trampoline. If you make a mistake when trying to perform a somersault, you could land on your head or neck. This will increase your chances of getting your neck or back broken, which could result in death or paralysis.

Foreign Objects:

DO NOT use the trampoline if there are pets, other people, or any objects underneath the trampoline. This will increase the chances of an injury occurring. DO NOT hold any foreign objects in your hand and DO NOT place any objects on the trampoline while anyone is playing on it. Please be aware of what is overhead when you are playing on the trampoline. Tree limbs, wires, or other objects located over the trampoline will increase your chances of getting injured.

Poor Maintenance of Trampoline:

A trampoline in poor condition will increase your risk of getting injured. Please inspect the trampoline before each use for bent steel tubes, torn mat, loose or broken springs, and overall stability of the trampoline.

Weather Conditions:

Please be aware of the weather conditions when using the trampoline. If the mat of the trampoline is wet, the jumper could slip and injure him or herself. If it is too windy, jumpers could lose control.

Use the trampoline only when the jumping mat is clean and dry. A wet jumping mat is extremely slick and prevents a stable landing.

Windy conditions:

In severe wind situations, the trampoline can be blown about. If you expect windy weather conditions, the trampoline should be moved to a sheltered area or disassembled. Another option is to tie the round, outside portion (top frame) of the trampoline, to the ground using ropes and stakes. To ensure security, at least four (4) tie downs should be used. Do not just secure the legs of the trampoline to the ground because they can pull out of the frame sockets.

Moving the trampoline:

If you need to reposition the trampoline, two people should be used. All connector points should be wrapped and secured with weather resistant tape, such as duct tape. This will keep the frame intact during the move and prevent the connector points from dislocating and separating. When moving, lift the trampoline slightly off the ground and keep it horizontal to the ground.

Limit Access:

When the trampoline is not in use, always store the access ladder in a secure place so that unsupervised children cannot play on the trampoline.

TIPS TO REDUCE THE RISK OF ACCIDENTS

All jumpers need to be supervised, regardless of skill level or age.

Jumpers' role in accident prevention

The key here is to stay in control of your jumps. DO NOT move onto more complicated, more difficult maneuvers until you have mastered the basic, fundamental bounce. Education is also key to safety and very important. Read, understand, and practice all safety precautions and warnings prior to using the trampoline. A controlled jump is when you land and take off from the same location.

For additional safety tips and instructions, contact a certified trampoline instructor.

Supervisor's or owner's role in accident prevention

Supervisors need to understand and enforce all safety rules and guidelines. It is the responsibility of the supervisor to provide knowledgeable advice and guidance to all jumpers of the trampoline. If supervision is unavailable or inadequate, the trampoline should be stored in a secure place, disassembled to prevent unauthorized use, or covered with a heavy tarp that can be locked or secured with lock or chains. The supervisor is also responsible to ensure that the safety placard is placed on the trampoline and that jumpers are informed of these warnings and instructions.

ADDITIONAL TRAMPOLINE SAFETY INSTRUCTIONS

JUMPERS

- ◆ Do not use the trampoline if you have consumed alcohol or drugs
- ◆ Remove all hard and sharp objects from person before using trampoline
- ◆ You should climb on and off in a controlled and careful manner. Never jump on or off the trampoline and never use the trampoline as a device to bounce onto or into another object
- ◆ Always learn the basic bounce and master each type of bounce before trying more difficult types of bounces. Review the Basic Skills Section to learn how to do the basics
- ◆ To stop your bounce, flex your knees when you land on the mat with your feet
- ◆ Always be in control when you are bouncing on the trampoline. A controlled jump is when you land at the same spot that you took off from. If at any time you feel out of control, try to stop bouncing
- ◆ Keep your eyes on the mat to maintain control. If you do not, you could lose balance or control
- ◆ Always have a supervisor watching you when you are on the trampoline

SUPERVISORS

- ◆ Educate yourself with the basic jumps and safety rules. To prevent and reduce the risk of injuries, enforce all safety rules and ensure that new jumpers learn the basic bounces before trying more difficult and advanced jumps
- ◆ All jumpers need to be supervised, regardless of skill level or age
- ◆ Never use the trampoline when it is wet, damaged, dirty, or worn out. The trampoline should be inspected before any jumpers start bouncing on it
- ◆ Keep all objects that could interfere with the jumper away from the trampoline. Be aware of what is overhead, underneath, and around the trampoline

LESSON PLAN

The following lessons are suggested in order to learn basic steps and bounces before moving onto more difficult, complicated bounces. Before actually getting on and using the trampoline, you should read and understand all safety instructions. A complete discussion and demonstration of body mechanics and trampoline guidelines should occur between the supervisor and student as well.

Lesson 1

- A. Mounting and Dismounting-Demonstration of proper techniques
- B. The Basic Bounce-Demonstration and practice
- C. Braking (Check the Bounce-Demonstration) and practice. Learn to brake on command
- D. Hands and knees-Demonstration and practice. Stress should be on four-point landing and alignment

Lesson 2

- A. Review and practice of techniques learned in Lesson 1
- B. Knees Bounce-Demonstration and practice. Learn the basic down to knee and back up before trying half twist to left and right
- C. Seat Bounce-Demonstration and practice. Learn basic seat bounce then add a knee bounce, hands and knees; repeat.

Lesson 3

- A. Review and practice skills and techniques learned in previous lessons
- B. Front Drop-To avoid mat burns and teach the front bounce position, all students should be requested to assume

the prone position (face down on the ground) while the instructor checks for faulty positions that could cause injury.

- C. Start with a hands and knees bounce and then extend body into prone position, and on the mat and return to feet.
- D. Practice Routine-Hands and knees Bounce, Front Bounce, back to feet, seat bounce, back to feet, seat bounce, back to feet

Lesson 4

A. Review and practice skills and techniques learned in previous lessons

B. Half-Turn

- i. Start from front drop position and as you make contact with mat, push off with arms in either the right or left direction and turn head and shoulders in same direction.
- ii. During turn, be sure to keep back parallel to mat and head up.
- iii. After completing turn, land in front drop position

After completing this lesson, the student now has a basic foundation of trampoline bounces. Jumpers should be encouraged to try and develop their own routines with the emphasis on control and form.

A game that can be played in order to encourage students to try develop routines is “BOUNCE”. In this game, players count off from 1 to X. Player one starts with a maneuver. Player two has to do Player one’s maneuver and add on another. The first player who cannot do the routine properly in the correct sequence receives the letter “B”. This continues until someone spells out the word “BOUNCE”. The last remaining contestant is deemed the winner! Even when playing this game, it is important to perform your routines under control and not try difficult or highly skilled bounces that you have not yet mastered.

A certified trampoline instructor should be contacted to further develop your trampoline skills.

BASIC TRAMPOLINE BOUNCES

THE BASIC BOUNCE

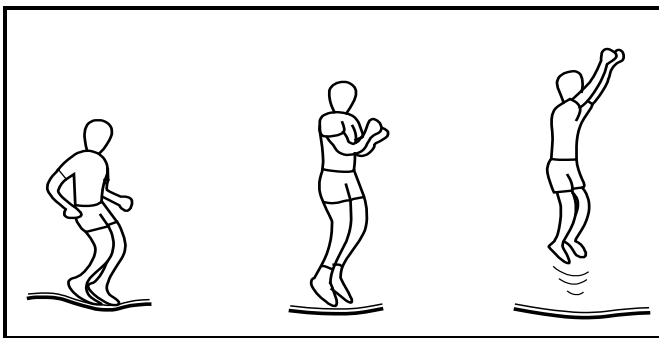

1. Start from standing position, feet shoulder width apart and with head up and eyes on mat.
2. Swing arms forward and up and around in a circular motion.
3. Bring feet together while in mid-air and point toes downward.
4. Keep feet shoulder width apart when landing on mat.

KNEE BOUNCE

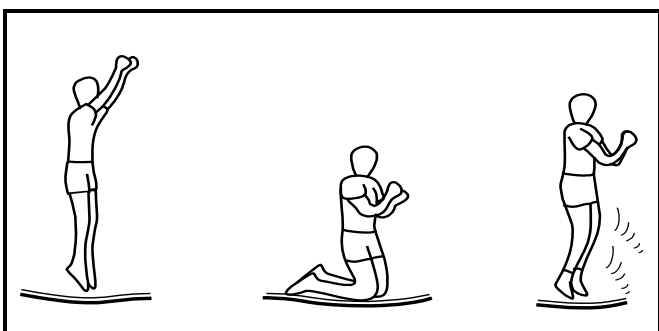

1. Start with basic bounce and keep it low.
2. Land on knees keeping back straight, body erect and use your arms to maintain balance.
3. Bounce back to basic bounce position by swinging arms up.

SEAT BOUNCE

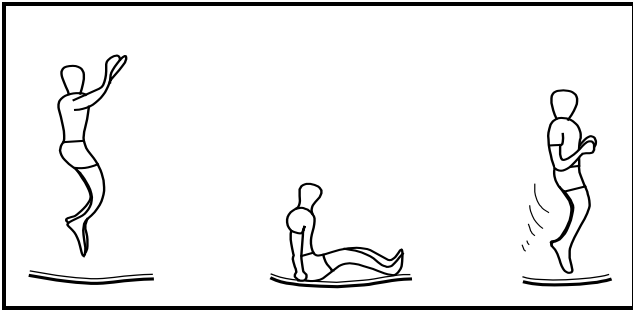

1. Land in a flat sitting position.
2. Place hands on mat besides hips, do not lock your elbow.
3. Return to erect position by pushing with hands.

FRONT BOUNCE

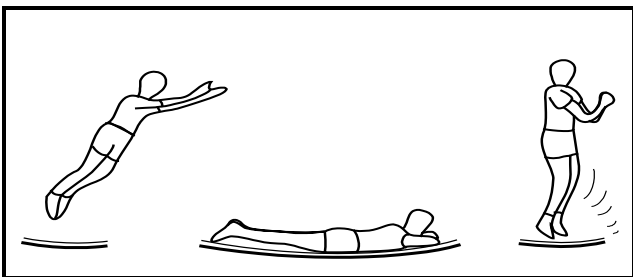

1. Start with a low bounce.
2. Land in prone (face down) position and keep hand and arms extended forward on mat.
3. Push off the mat with arms to return to standing position.

180 DEGREE BOUNCE

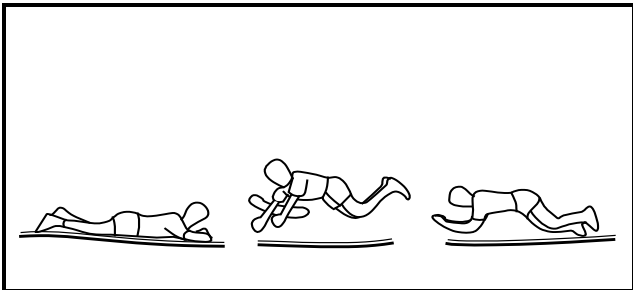

1. Start with front bounce position.
2. Push off with left or right hands and arms (depending on which way you wish to turn).
3. Maintain head and shoulders in the same direction and keep back parallel to mat and head up.
4. Land in prone position and return to standing position by pushing up with hands and arms



WARNING:

ALWAYS START YOUR JUMP AT THE MIDDLE OF TRAMPOLINE MAT.

TRAMPOLINE PLACEMENT

The minimum overhead clearance required is 7.3 meters.

For safe use of the trampoline, please be aware of the following when selecting a place for your trampoline:

- Make sure it is placed on a level surface
- The area is well-lit
- There are no obstructions beneath the trampoline

If you do not follow these guidelines, you increase the risk of someone getting injured.

ASSEMBLY INSTRUCTIONS

To assemble this trampoline, all you need is our special spring loading tool provided with this product. During periods of non-use, this trampoline can be easily disassembled and stored. Please read the assembly instructions before beginning to assemble the product. It is recommended that no less than 2 persons participate in the assembly of this product.







PRIOR TO ASSEMBLING

Please refer to this page for parts descriptions and numbers. The assembly steps use these descriptions and numbers as reference for your convenience.

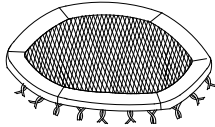

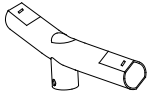
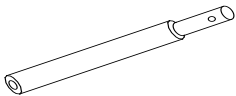
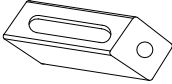
Make sure that you have all parts listed. If you are missing any parts, please refer to this page for instructions on how to attain any parts.

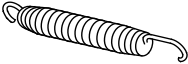
To prevent any injuries to your hands from pinch points during assembly, please use gloves to protect your hands.

PARTS LIST USE FOR TRAMPOLINE

Key Number	Parts	Description	Quantity
1		Trampoline Mat, stitched with Triangle-Rings and Safety Pad	1
2		Top Rail	6
3		Corner Top Rail with socket	6
4		Vertical Leg Extension	6
5		Plastic Vertical Leg Extension	6
6		Plastic Horizontal Leg Base	3
8		R-hooked Galvanized Springs	36
10		Safety Instruction Placard	1

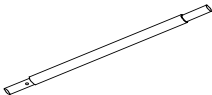
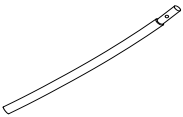
PARTS LIST USE FOR ENCLOSURE

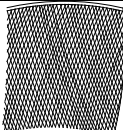
Key Number	Parts	Description	Quantity
11		Straight Frame Tube with Foam	6
12		Curve Frame Tube with Foam	6
13		Horizontal Tube with Foam	3
14		Enclosure Netting	1

HARDWARE USE FOR TRAMPOLINE AND ENCLOSURE

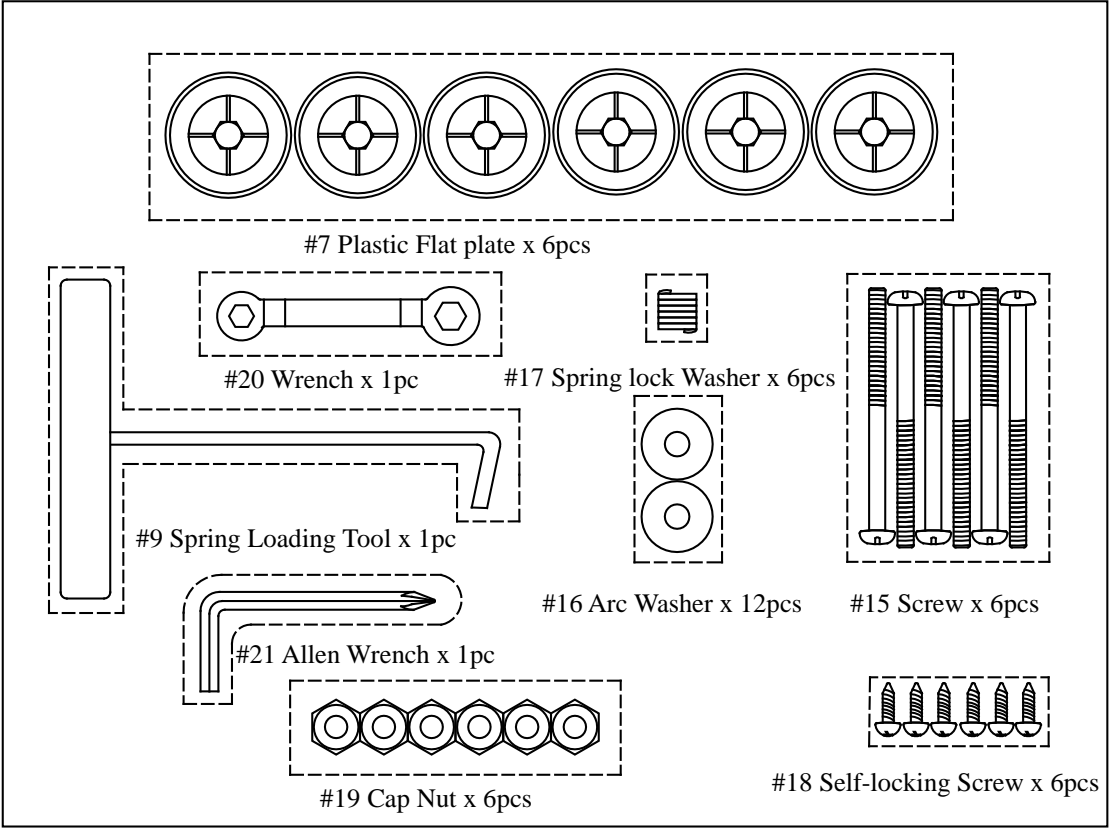

Key Number	Part Number	Key Number	Part Number
7	PFP-84	18	ESLS-84
9	TSLT	19	ECN-84
15	Screw	20	Wrench
16	EAW-84	21	Allen Wrench
17	ESLW-84		

REMEMBER TO USE GLOVES DURING ASSEMBLY TO AVOID PINCHING.
 AT LEAST 2 PEOPLE ARE REQUIRED TO ASSEMBLE THE TRAMPOLINE.

ASSEMBLY INSTRUCTIONS

STEP 1 – Support Assembly

Attach the Vertical leg extension (#4) into the hole on the Plastic Horizontal Leg Base (#6) and Plastic Vertical Leg Extension (#5) secured by using Plastic Flat plate (#7) and Allen Wrench as shown in FIGURE 1. Repeat this step for all the Leg bases.

Note: Only inserts 1/3 of the plastic thread to the Vertical Leg Extension (#4).

Please don't tighten Plastic Flat plate (#7) at this step.

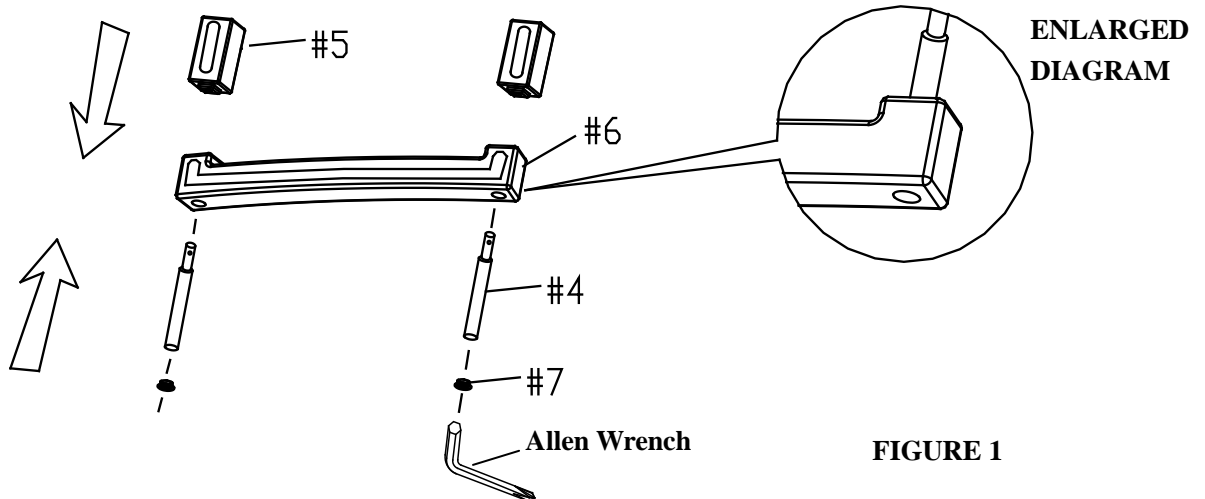
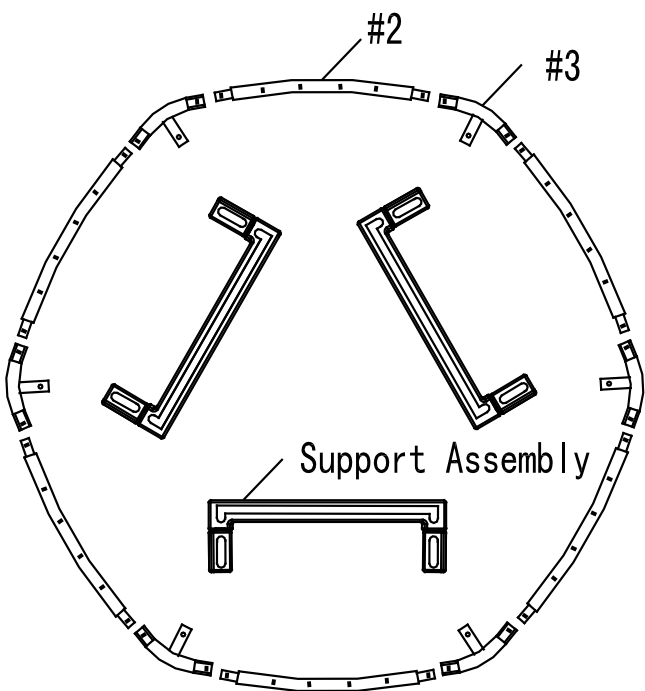

FIGURE 1

STEP 2 – Frame layout

There are a total of 12 pieces of tubing parts and 3 sets Support Assemblies (pre-assembled in STEP 1) that are needed to assemble the frame. All parts with the same part number are interchangeable and have no "right" or "left" orientation.

Lay out all parts according to FIGURE 2.



- A. Lay out all frame sections in a circle as shown. Please pay special attention to the sequence of this assembly step.
- B. You should have the following parts:
 - ① Top Rail (#2 , 6 pieces)
 - ② Corner Top Rail with socket (#3 , 6 pieces)
 - ③ Support Assemblies (3 sets)

FIGURE 2

STEP 3

Insert the Corner Top Rail with socket (#3) to the Support Assembly as shown in FIGURE 3
Repeat this step for all the Corner Top Rail with socket.

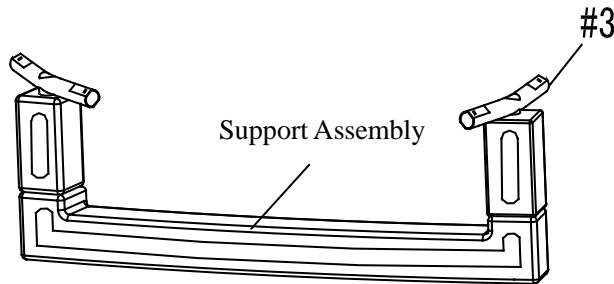

FIGURE 3

STEP 4

- Please have someone helping you to hold the frame tube.
- Be steady when you do this step.

Attach the Straight Frame tube with foam (#11) to the Socket on the Corner Top Rail with socket for the Trampoline as shown in FIGURE4, then secured the pole by using Screw (#15), Arc Washer (#16), Spring Lock Washer (#17), and Cap Nut (#19) as shown in the Enlarged Diagram in FIGURE 4. Repeat in the same manner for all Straight Frame tube with foam (#11)

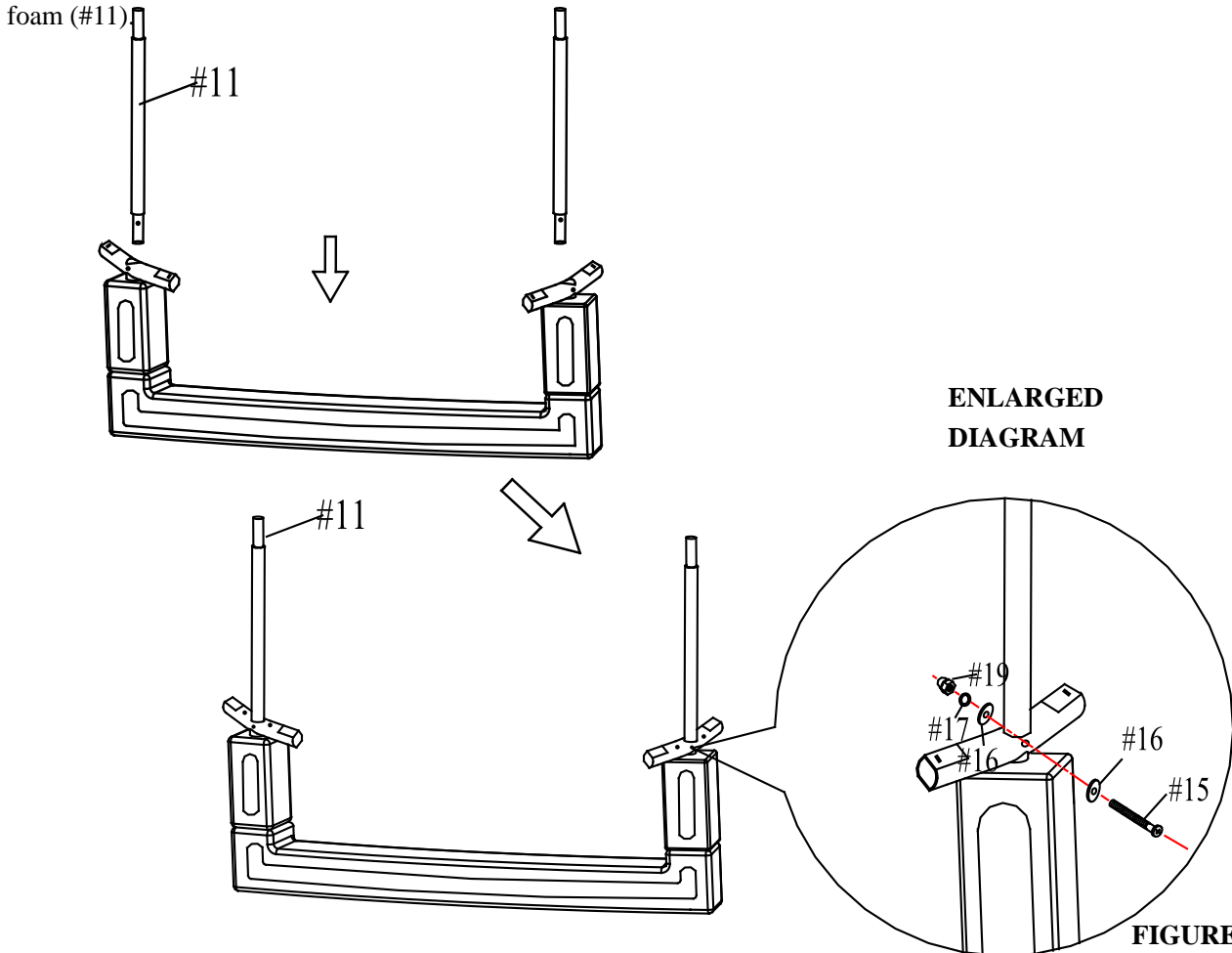



FIGURE 4

! Important note: Please make sure the hole on the Straight Frame Tube with Foam (#11) matches with the hole on the socket on the Corner Top Rail with socket; slightly rotate the straight Frame Tube with Foam (#11) if needed.

STEP 5

Slide the Top Rail (#2) to the Corner Top Rail with socket as shown in FIGURE 5. To connect the parts, simply slide a section (male) of tubing that is smaller on one end into the adjacent section (female) that has a larger opening.

 Important note: Please make sure the curve point of the Plastic Horizontal Leg base is facing outward!

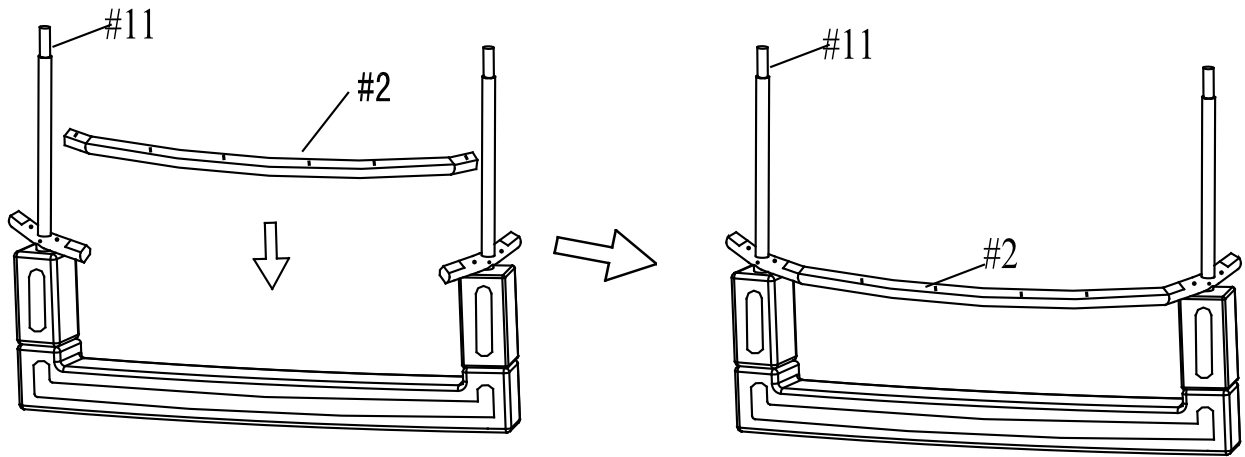

FIGURE 5

Now, go back to screw the other 2/3 plastic thread of the Plastic Flat plate (#7).

Plastic Flat plate (#7). Please do not over tighten it!

Trampoline Mat Assembly

STEP 6

Cover the Trampoline Frame Tubes by pulling the Trampoline Mat, stitched with Triangle-Rings and Safety Pad (#1) downward. The six holes at the corner of the Trampoline Mat, stitched with Triangle-Rings and Safety Pad (#1) should be inserted to the Lower Frame tube Foam (with one hole, take out foam before insert Safety Pad, and put it back after Safety Pad) (#11) as shown in FIGURE 6.

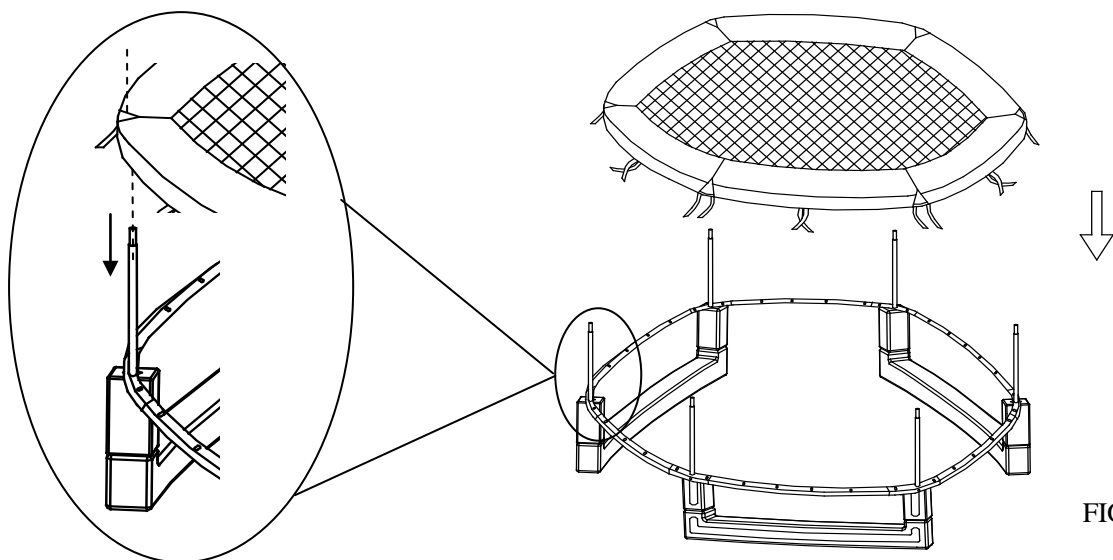

FIGURE 6

STEP 7

Lay out the Trampoline Mat with Safety Pad (#1) inside the frame with Safety Pad flip up as shown in FIGURE 7. There are total of 36 Triangle-rings sewn on the mat, and 36 holes on the Top Rail Frame. None are numbered so please follow the instructions carefully to ensure proper installation. Now, select an arbitrary point on the Top Rail Frame (call it ZERO) as shown in FIGURE 7.

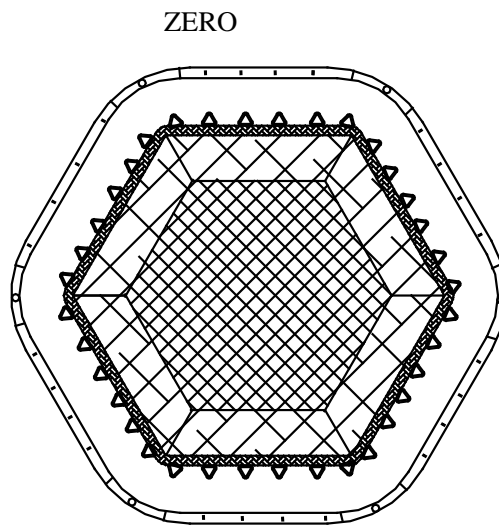

FIGURE 7

SPRING LOADING INSTRUCTION



CAUTION

- Make sure to flip up the safety pad for ease of installation of springs.
- Two adults are required in this assembling step.
- CAREFUL - When attaching the springs, please do not put your hands, legs, or body close to the connector points. The connector points can become pinch points since the trampoline is tightening up.
- Wear heavy duty working gloves to protect your hand.
- Use the special spring loading tool included.

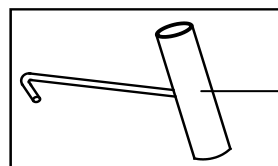

SPRING LOADING TOOL (9)

STEP 8

Attach the R-Hooked Galvanized Spring (#8) with “R” Hook end to the Triangle-Ring on the mat as shown below.

HINT: Holding the spring at 45 degree in relation to the mat surface will be much easier to install into Triangle -Ring. Hold the spring loading tool underhand and pull spring hook towards the point “ZERO” on the Top Rail frame as shown in FIGURE 8. Drop hook into frame hole until it latches on completely and tap it down if hook is not completely in the hole.

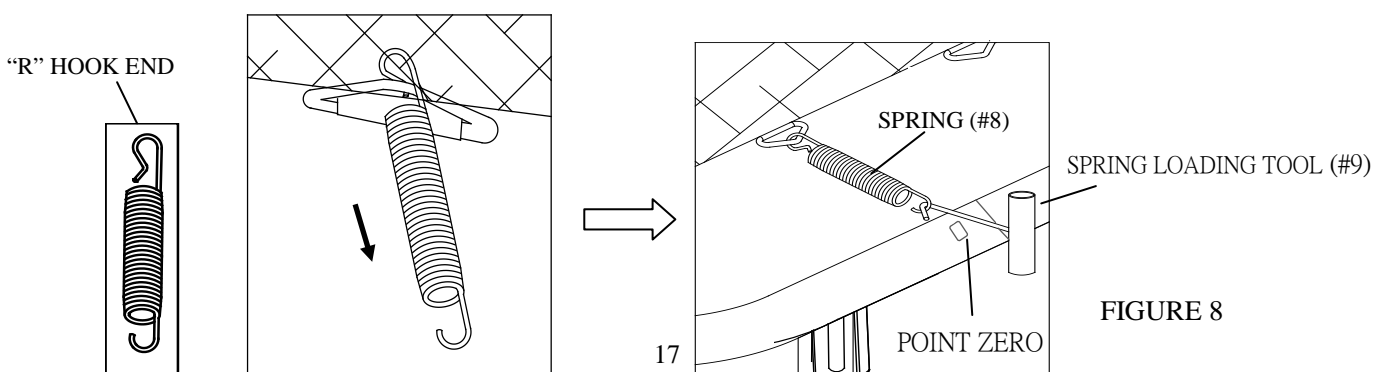

FIGURE 8

Then, attach a springs at the Corners Top Rail (#3) first as shown in FIGURE 9. For even distribution of tension and ease of assembly, springs should be placed on opposite sides of the mat/frame....i.e. 5, 6 then 23, 24; Zero, 35 then 17, 18, etc. Now, you should have 12 springs install at ZERO, 5, 6, 11, 12, 17, 18, 23, 24, 29, 30, and 35.

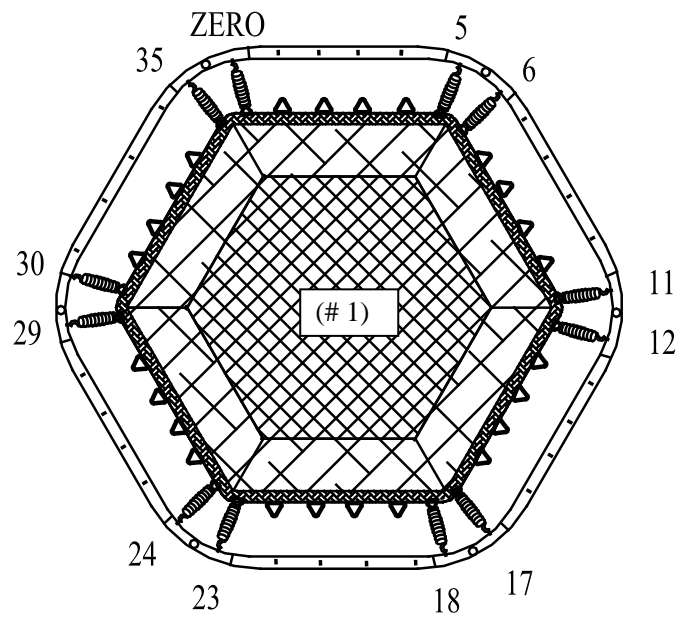

FIGURE 9

STEP 9

Attach a spring at every 3 holes and corresponding Triangle-rings. For even distribution of tension and ease of assembly, springs should be placed on opposite sides of the mat/frame....i.e. 3 then 21, 33 then 15, etc. In addition to the previously installed springs, you should have springs at 3, 9, 15, 21, 27, and 33 as shown in FIGURE 10.

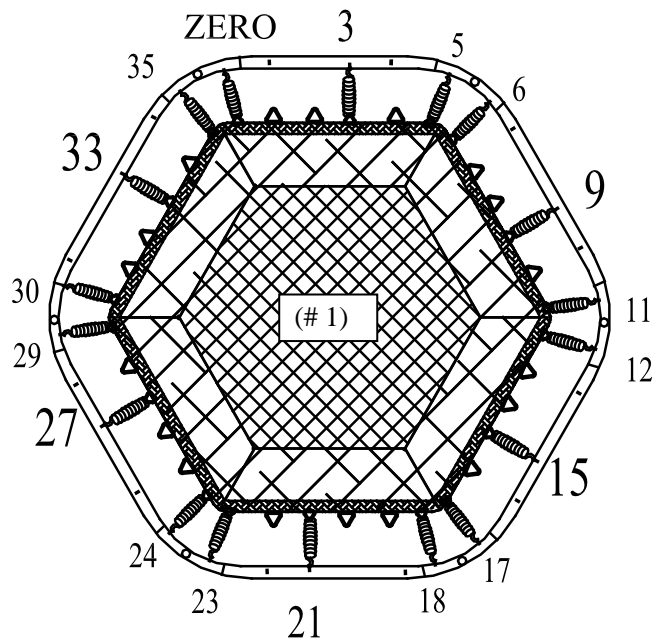

FIGURE 10

CAUTION:

If you notice that you have miscount a hole and Triangle-rings connection, recount and remove or attach any springs required to maintain the count of springs.

STEP 10

Then, attach the remaining 18 springs by using the same theory of counting equal holes as shown in FIGURE 11.

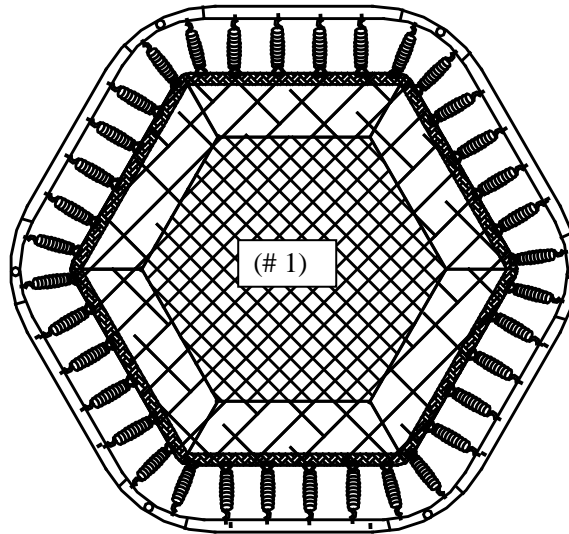

FIGURE 11

STEP 11

Flip down the Safety Pad stitched with the trampoline mat (#1). Pull tight the elastic straps over the frame as shown in FIGURE 12 and make sure safety pad covers the frame.

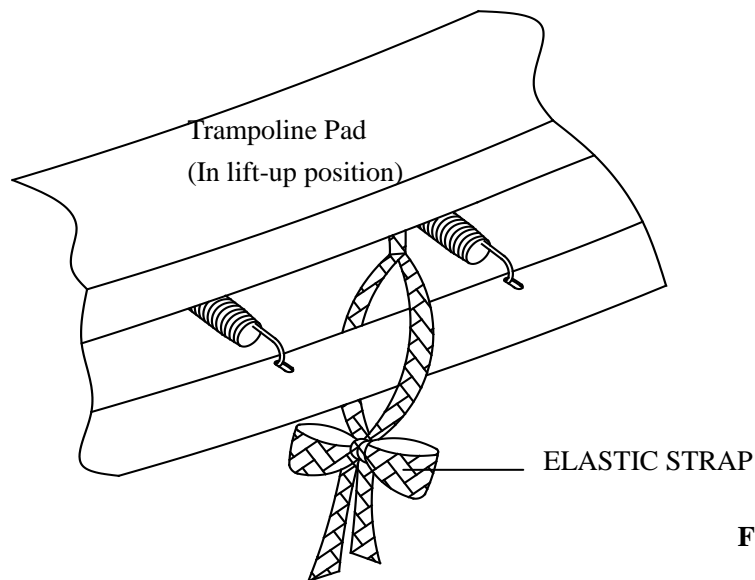

FIGURE 12

Perform a complete inspection of the trampoline to make sure all parts are assembled and attached properly. Read this entire manual and make sure all jumpers completely understand all of the safety rules printed in the manual and on the various warning signs. Instruct all jumpers in the basic bounces described in the manual.

! IMPORTANT NOTICE: Make sure the safety pad is securely attached to the frame and completely covers the frame and all springs before using this trampoline. Do not use trampoline if even one spring or Triangle-ring is damaged or missing.

STEP 12

Using the tie wrap, attach the Trampoline Safety Instruction Placard (#10) to the trampoline as shown in FIGURE 13. The tie wrap should go around the Top Rail to ensure that it doesn't slide off the trampoline.

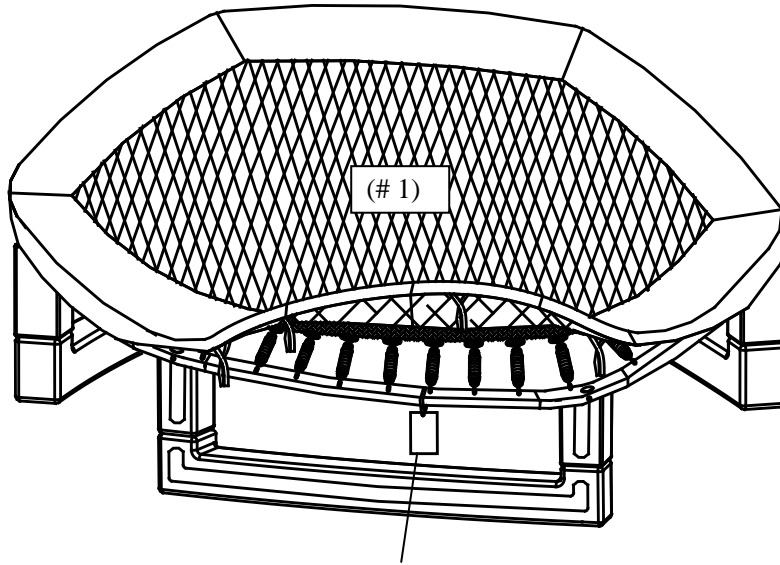

Safety Instruction Placard (#10)

FIGURE 13

Frame Pad Assembly

 **WARNING**

Never use the trampoline without attaching the frame pad. Properly tie down the frame pad before each use!!

STEP 13-Enclosure Assembly

 **CAUTION: TWO ADULTS ARE REQUIRED.**

Slide the Horizontal Tube with Foam (#13) through the pocket on top of the Enclosure Netting (#14), as shown in FIGURE 14-1. Attach the Horizontal Tube with Foam (#13) to the Curve Frame Tube with Foam (#12) to form an "ARCH" as shown in FIGURE 14-2 then tighten with self-locking screw (#18). Lay down the "ARCH" on the Mat for further use.

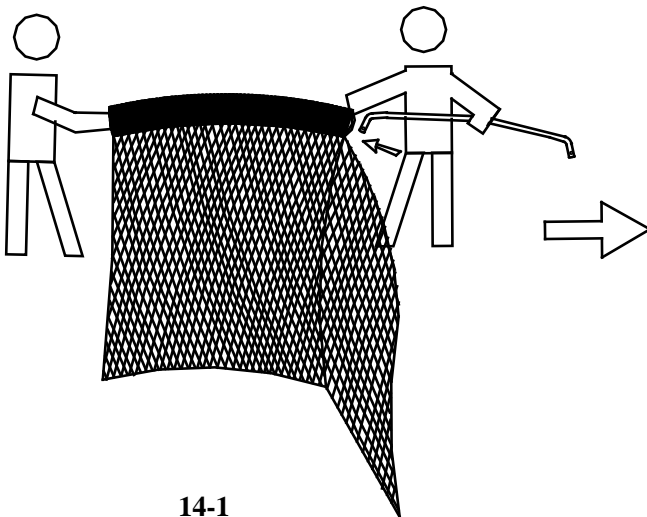

14-1

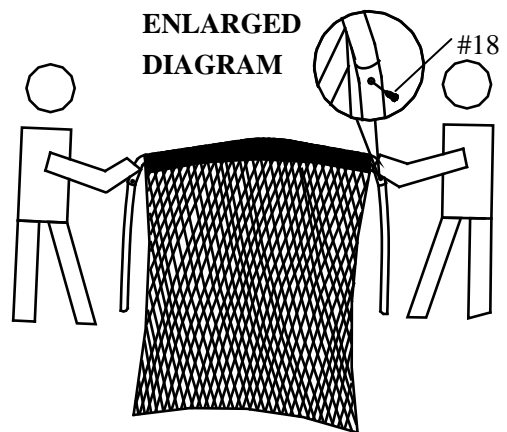

14-2

FIGURE 14

STEP 14



CAUTION: TWO ADULTS ARE REQUIRED

Fold up the Enclosure Netting over the top of the “ARCH” and attach the assembled “ARCH” to the Straight Frame Tube with Foam (#11) as shown in FIGURE 15.

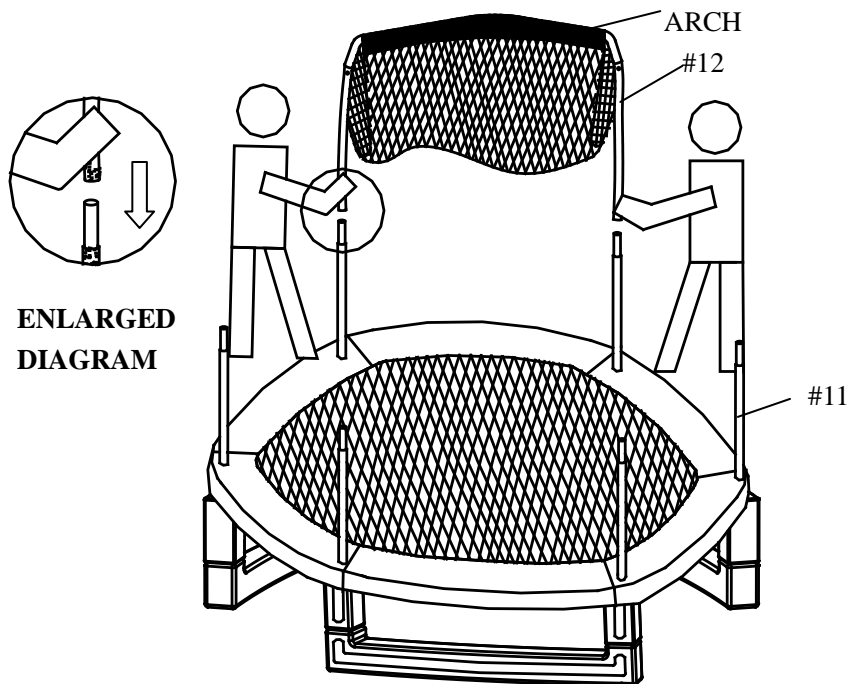

FIGURE 15

STEP 15

After all three “ARCHES” are attached to the Straight Frame Tube with Foam (#11), pull down and the Enclosure Netting evenly over the Straight Frame Tube with Foam (#11) as shown in FIGURE 16.

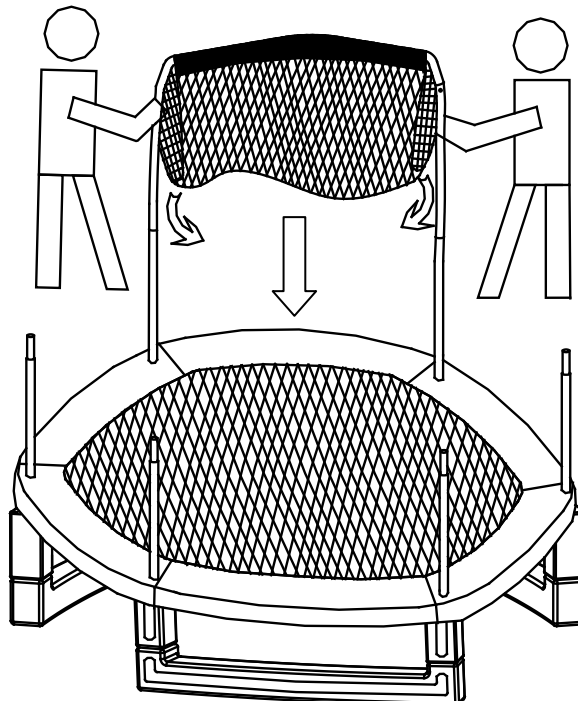

FIGURE 16



IMPORTANT NOTE!! When attaching the “ARCH” to the Straight Frame Tube with Foam please ensure the “ARCH” is aligned with the support assembly. The Enclosure Netting should wrap around the outside of the Straight Frame Tube with Foam when attaching the “ARCH” assembly. Please adjust the top of the enclosure netting by pulling the two ends of the enclosure arch cap and by pulling the elastic strap sewn on the enclosure netting downward.

STEP 16

Tie the elastic straps on the Enclosure Netting (#14) to the Trampoline Top Rail frame by looping around the triangle-rings on the trampoline mat and the Corner Top Rail with socket (#3) as shown in FIGURE 17.

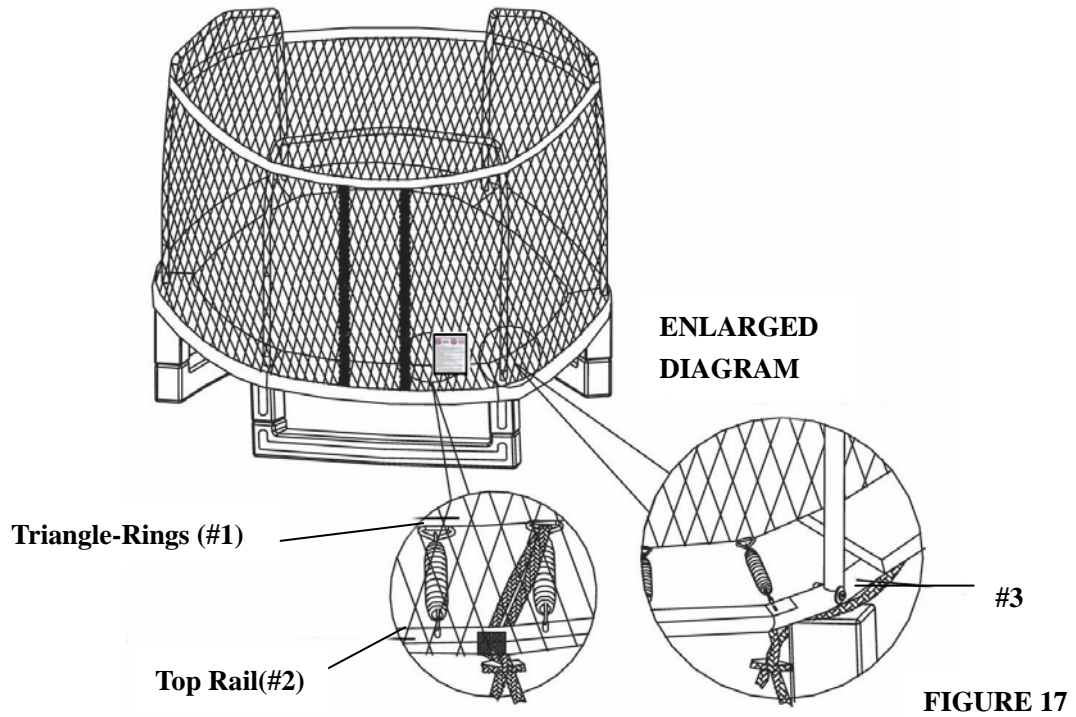
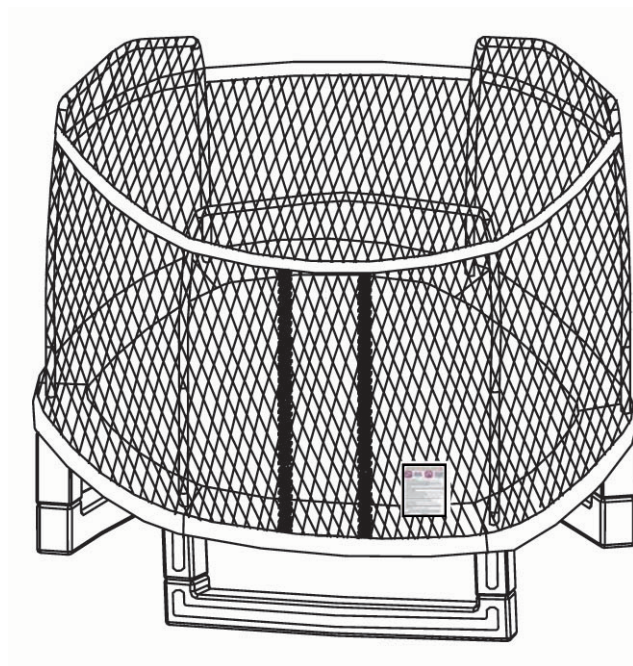

FIGURE 17

STEP 17

Pull the velcro of Enclosure Netting (#14) at the door



DISASSEMBLY

To disassemble the trampoline, follow assembly STEP 1 through STEP 17 in reverse order. Do not attempt to disassemble any frame components before the springs and the mat have been removed. Use gloves to protect your hands from pinch points during disassembly.

CARE AND MAINTENANCE AND USE INSTRUCTIONS MUST BE READ CAREFULLY BEFORE USING THE TRAMPOLINE!

CARE AND MAINTENANCE

This trampoline and trampoline enclosure was designed and manufactured with quality materials and craftsmanship. If proper care and maintenance is provided, it will provide all jumpers with years of exercise, fun, and enjoyment as well as reduce the risk of injury. Please follow the guidelines listed below:

This trampoline and trampoline enclosure are designed to withhold a certain amount of weight and use. Please make sure that only one person at any one time uses the trampoline. Also, the person should weigh less than 45kgs. Jumpers should either wear socks, gymnastics shoes, or be barefoot when using the trampoline. Please be aware that street shoes or tennis shoes should NOT be worn while using the trampoline. In order to prevent the trampoline mat from getting cut or damaged please do not allow any pets onto the mat. Also, jumpers should remove all sharp objects from their person prior to using the trampoline. Any type of sharp or pointed objects should be kept off the trampoline mat at all times.

Always inspect the trampoline and trampoline enclosure before each use for worn, abused or missing parts. A number of conditions could arise that may increase your chances of getting injured. Please be aware of:

- Punctures, frays, tears, or holes worn in the mat, frame padding, barrier or support system (frame) padding
- Missing, improperly positioned, or insecurely attached frame padding or barrier or enclosure support system (frame) padding and pole caps.
- Sagging trampoline mat or barrier.
- Loose stitching or any kind of deterioration of the mat, barrier or support system (frame) padding.
- Bent or broken frame parts (legs and/or rails)
- Broken, missing, or damaged springs
- Damaged, missing, or insecurely attached frame pad
- Protrusions of any types (especially sharp typed) on the frame, springs, mat or suspension.

IF YOU FIND ANY OF THE PREVIOUS CONDITIONS, OR ANYTHING ELSE THAT YOU FEEL COULD CAUSE HARM TO ANY USER, THE TRAMPOLINE SHOULD BE DISASSEMBLED OR SECURED FROM USE UNTIL THE CONDITION (S) HAS BEEN RESOLVED.

MOVING THE TRAMPOLINE

If you need to move the trampoline, two people should be used. All connector points should be wrapped and secured with weather resistant tape, such as duct tape. This will keep the frame intact during the move and prevent the connector points from dislocating and separating. When moving, lift the trampoline slightly off the ground and keep it horizontal to the ground. For any type of other move, you should disassemble the trampoline.

WARNING!!

IF YOU FIND ANY OF THE PREVIOUS CONDITIONS, OR ANYTHING ELSE THAT YOU FEEL COULD CAUSE HARM TO ANY USER, THE TRAMPOLINE SHOULD BE DISASSEMBLED OR SECURED FROM USE UNTIL THE CONDITION(S) HAS BEEN RESOLVED.

WARNING!!

PLEASE READ ENTIRE INSTRUCTION BOOKLET BEFORE YOU USE THIS TRAMPOLINE.

Warranty

AUSTRALIAN CONSUMER LAW

Many of our products come with a guarantee or warranty from the manufacturer. In addition, they come with guarantees that cannot be excluded under the Australian Consumer law. You are entitled to a replacement or refund for a major failure and compensation for any other reasonably foreseeable loss or damage.

You are entitled to have the goods repaired or replaced if the goods fail to be of acceptable quality and the failure does not amount to a major failure. Full details of your consumer rights may be found at www.consumerlaw.gov.au

Please visit our website to view our full warranty terms and conditions:

<http://www.lifespankids.com.au/Warranty-Policy-Kids>

Please send all warranty and support inquiries through our ticketing system via the email address: support@lifespankids.com.au.

Head Office and Customer Service:

Global Fitness and Leisure Pty Ltd

17 Fordson Rd

Campbellfield

VIC, 3061

Australia

PH: 03 9357 2166

