



LK45 Sunset Picnic Table with Umbrella Instructions



WARNING!

Not suitable for children under 3 years until fully assembled. Small parts. Choking hazard.

IMPORTANT RETAIN FOR FUTURE REFERENCE: READ CAREFULLY

The owner's manual contains safety, assembly, use and maintenance instructions. The product must be assembled by an adult who has read and understood these instructions. Keep the packaging away from children and dispose of all packaging before use.

For the installer and your children's safety, it is important to fully read and understand the instructions and safety hazards before commencing the assembly of the product.

This manual may be subject to change. Please view our website www.lifespankids.com.au for the most recent version of this manual

Safety

- ⚠ Only adults should assemble or disassemble this product.
- ⚠ This product may contain sharp edges and small parts prior to assembly - product must be assembled by an adult
- ⚠ This product is safely designed for children between the ages of 2 years and up.
- ⚠ Maximum user weight: 60kg per seat
- ⚠ Adult supervision of children is required at all times when on or around this product. We advise that parents should observe and ensure that their children have the strength and skills to enjoy all the equipment safely before using them on their own.
- ⚠ To prevent serious injury do not allow children to play on the product until it is completely assembled and installed.
- ⚠ Children using this product should only use the product in the manner intended. i.e. do not climb on top of the table
- ⚠ Umbrella not suitable in strong winds. Remove umbrella in periods of strong winds
- ⚠ Product is designed for domestic use only

Timber

Our product was manufactured from premium timber with great care dealt in selecting, machining and treating the timber before it is sold to you.

Bear in mind that timber is a natural product and may experience changes throughout the course of its life. It may:

- Develop openings (gaps, slits, apertures, cracks) along the line of the grain. This occurs due to moisture content between internal and outer surfaces of the timber. It is totally acceptable and will not affect the integral strength, life or guarantee of the product.
- Fade as the timber reacts with sunlight. The timber should be treated with a proprietary product to act as a protective barrier (i.e. a watery repellent on an annual basis)
- Warp and distort its shape. Any distortion will be slight and will not affect the safety or enjoyment of this product.







For more information on our wood: <https://www.lifespankids.com.au/pages/natural-timber>

Assembly

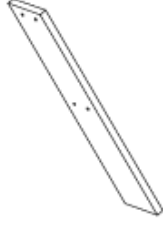
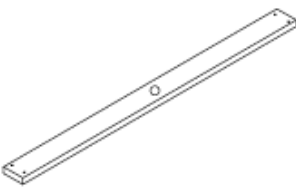
This product contains pre-assembled parts for easier assembly.

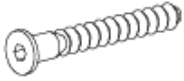
One adult is required for the assembly or disassembly of the product.

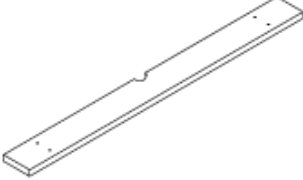
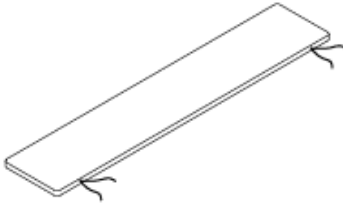
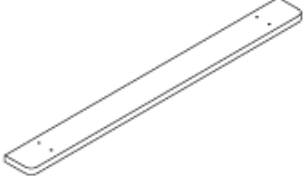
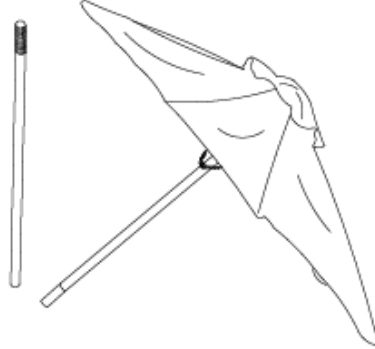
Do not allow children to play on the product until it is complete assembled and installed

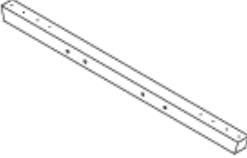
| | | | | | |
|--|---|------|---|--|------|
|  | | 5 |  | 4pcs | |
| | | 6 |  | 1pc | |
| | | A |  3.5*40mm | 36pcs | |
| | | B |  ∅6*45mm | 16pcs | |
| | | C |  | 1pc | |
| 1 |  | 2pcs | D |  | 2pcs |
| 2 |  | 6pcs | E |  | 1pc |
| 3 |  | 2pcs | | | |
| 4 |  | 2pcs | | | |

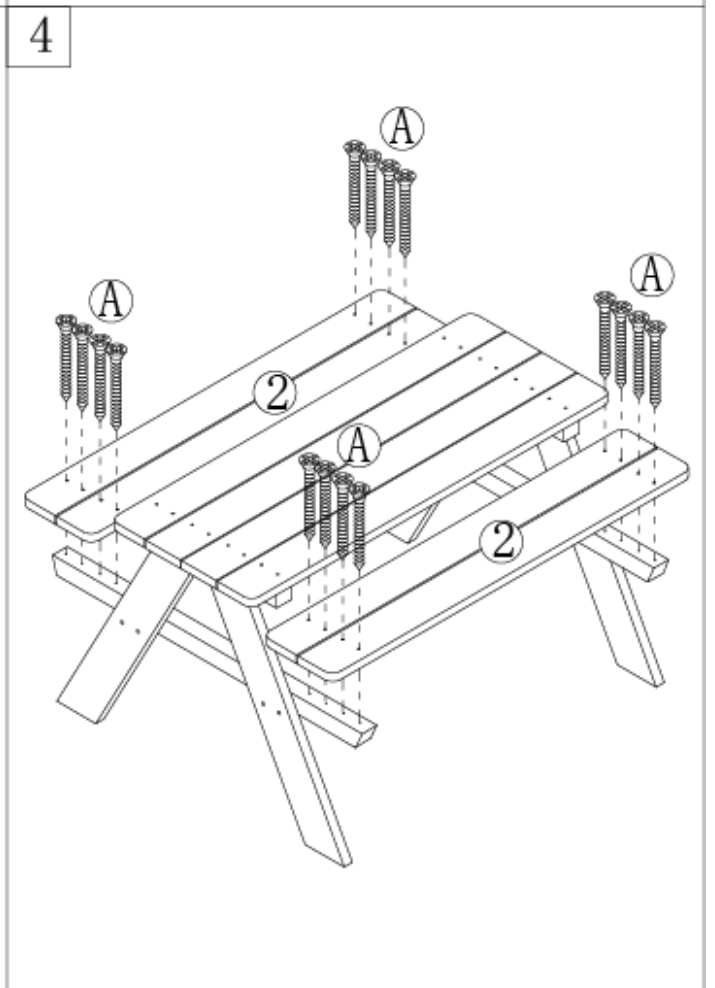
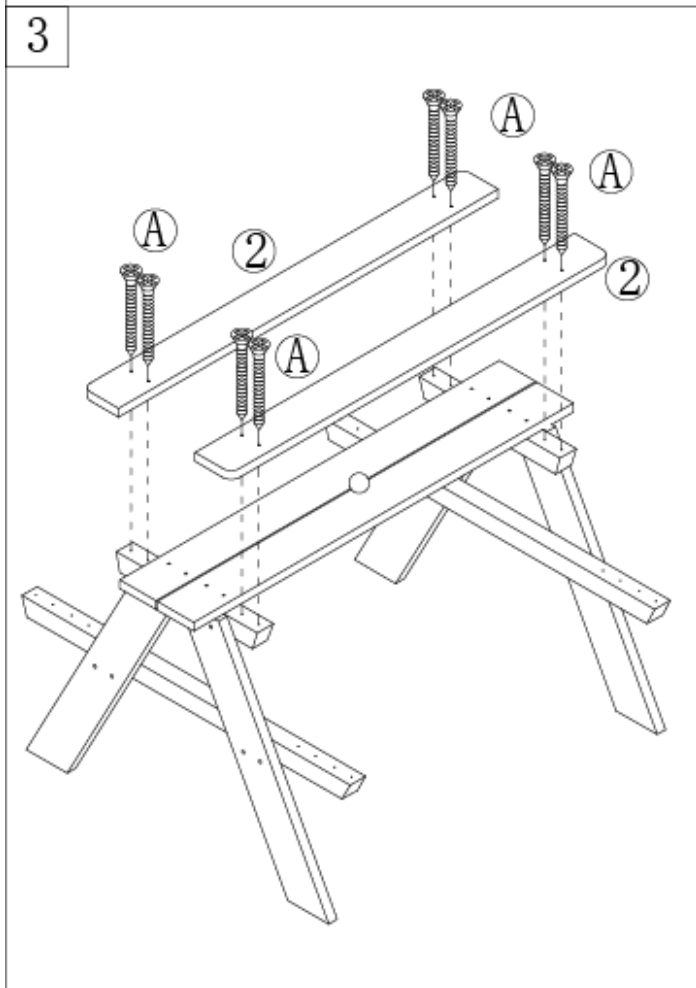
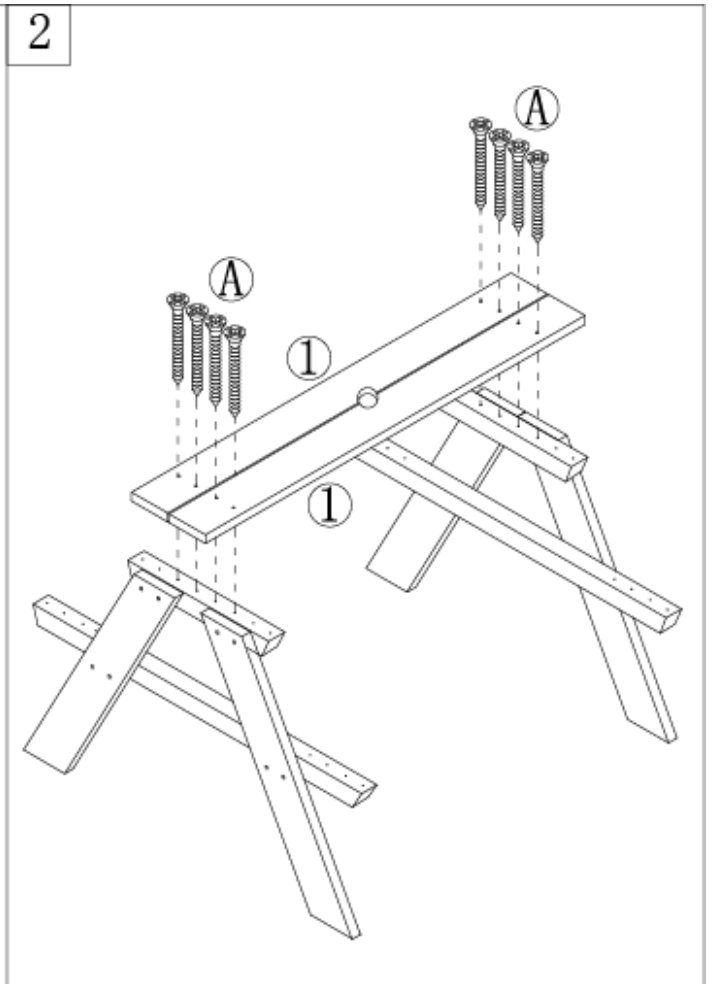
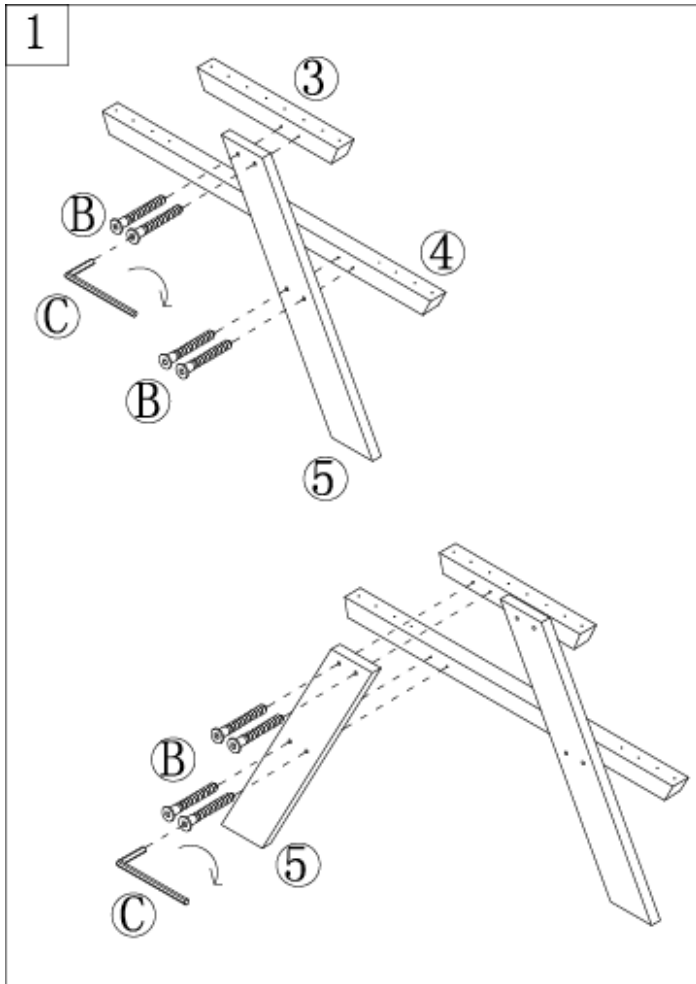

5

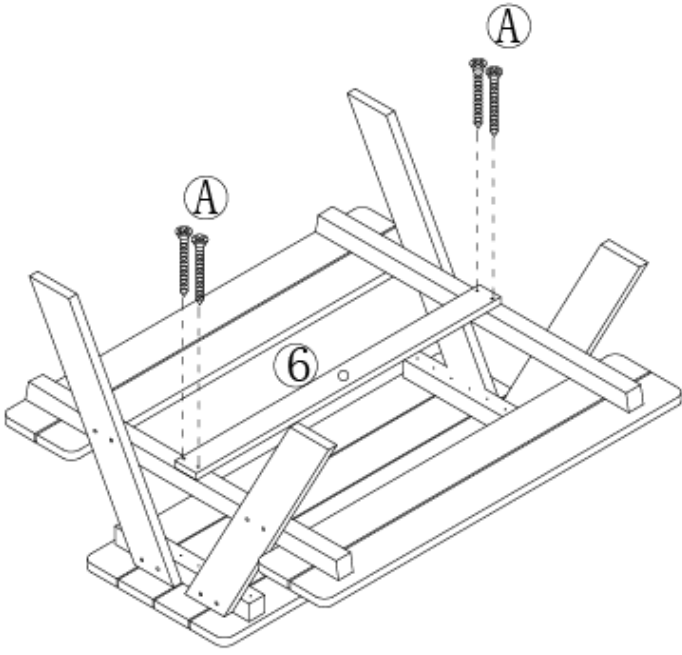

6

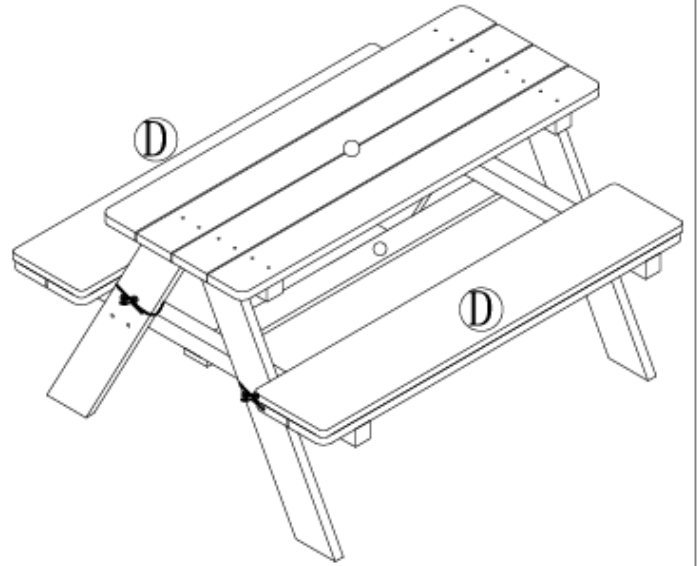

7

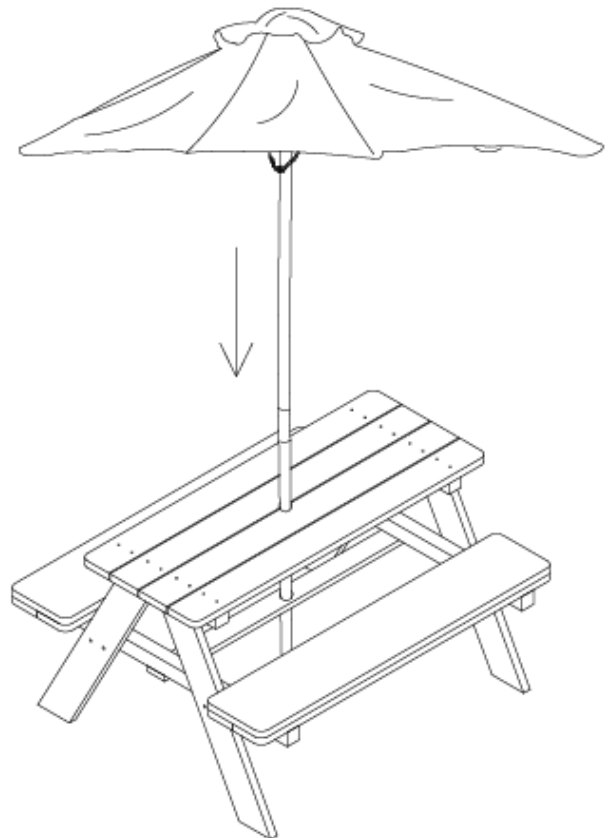
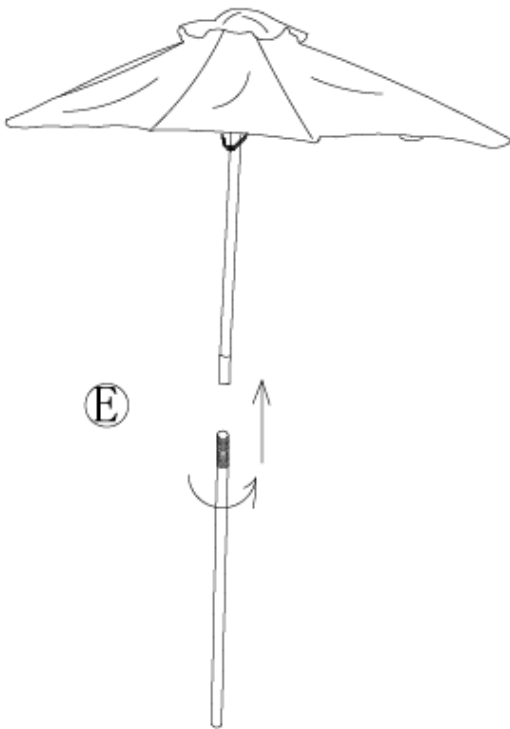

Care and Maintenance

We recommend regular maintenance should be conducted at the beginning of each season for your play equipment to ensure all main parts/fixings are tightly secured, well-oiled and intact to avoid injury or hazard.

We advise the following tips where applicable:

1. Tighten all hardware.
2. Lubricate all metallic moving parts
3. Check all protective coverings on bolts, pipes, edges and corners. Replace if they are loose, cracked or missing
4. Check metal parts for rust. Replace as needed
5. Prevent weathering by applying protective barriers to your timber via proprietary products to maintain its quality.
6. Attachments must be regularly examined for evidence of deterioration. Replace any attachments if there are signs of deterioration.

Warranty

AUSTRALIAN CONSUMER LAW

Many of our products come with a guarantee or warranty from the manufacturer. In addition, they come with guarantees that cannot be excluded under the Australian Consumer law. You are entitled to a replacement or refund for a major failure and compensation for any other reasonably foreseeable loss or damage.

You are entitled to have the goods repaired or replaced if the goods fail to be of acceptable quality and the failure does not amount to a major failure. Full details of your consumer rights may be found at

www.consumerlaw.gov.au

Please visit our website to view our full warranty terms and conditions:

<http://www.lifespankids.com.au/Warranty-Policy-Kids>

Please send all warranty and support inquiries through our ticketing system via the email address:

support@lifespankids.com.au.

Head Office and Customer Service:

Global Fitness and Leisure Pty Ltd

17 Fordson Rd

Campbellfield

VIC, 3061

Australia

PH: 03 9357 2166

