

USER MANUAL

Anchor Kit (Set of 4pcs)

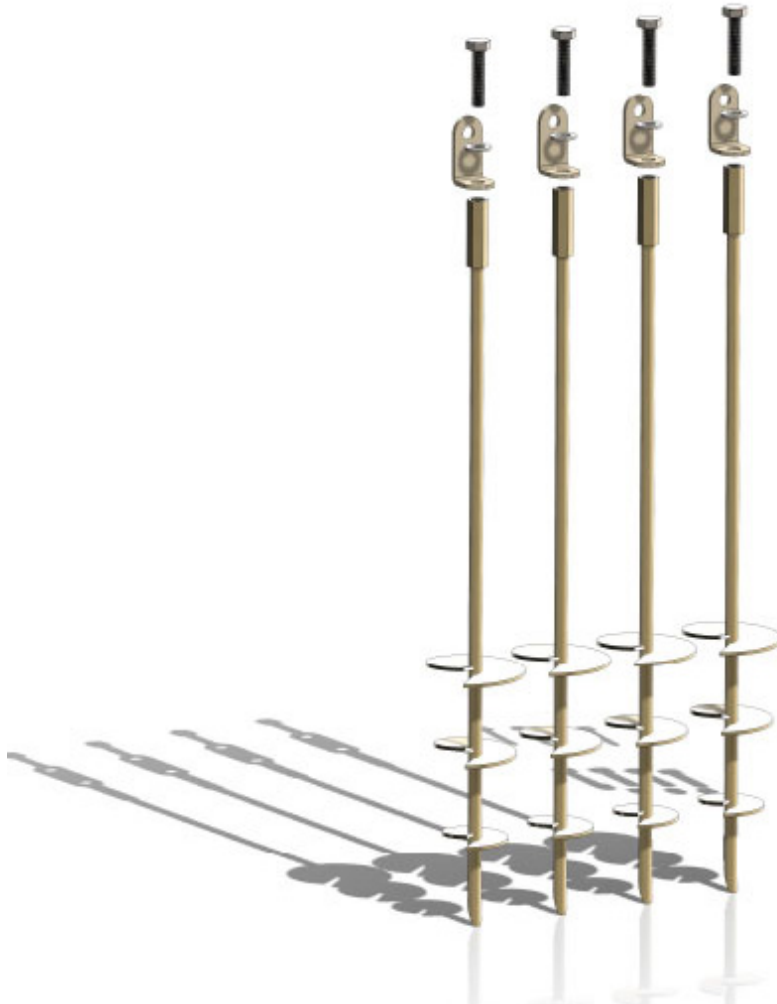

Find the Digital
Manual Online



WARNING: The disassembled product may contain small parts which pose a choking hazard to children under 3.

IMPORTANT:

This product may contain sharp points and small parts prior to assembly. The owner's manual contains safety, assembly, use and maintenance instructions. This product must be assembled by an adult who has read and understood these instructions. Keep the packaging away from children and dispose of all packaging before use.

For the installer and your children's safety, it is important to fully read and understand the instructions and safety hazards before commencing the assembly of the product.

NOTE:

This manual should not be used to guide your purchasing decision. Your product, and the contents inside its carton, may vary from what is listed in this manual. This manual may also be subject to updates or changes. Updated manuals are available through our website at www.lifespankids.com.au.

ASSEMBLY INSTRUCTIONS

PARTS LIST



CAUTION: Package contains small parts keep away from children. Choking hazard.

M8 x 35mm 4pcs.
 L Shape Plate 4pcs.
 Washer 8pcs.
 Anchor 400mm Long 4pcs.

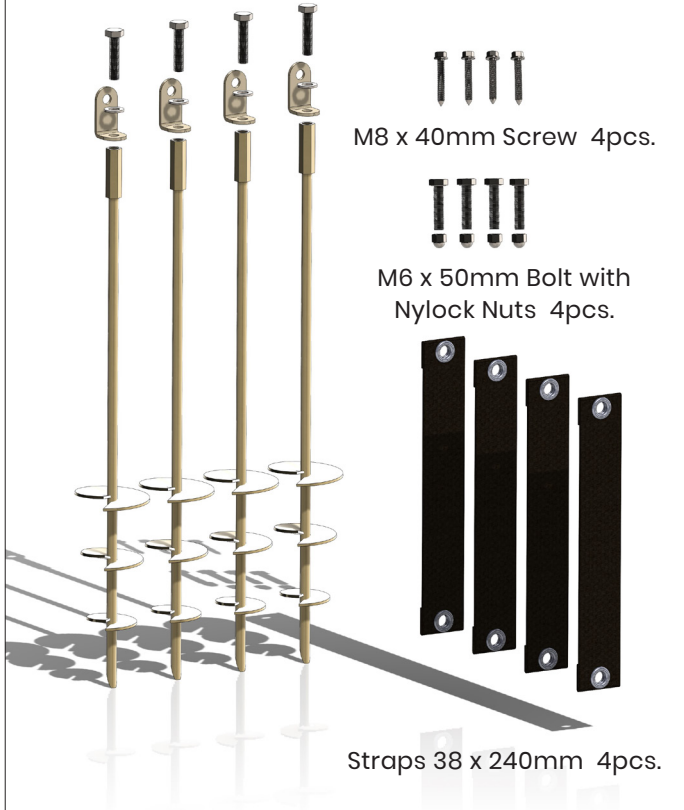

SET UP



Easy to Install & Use

**11mm Power Nuts
 Driver Drill Bits
 (Adapters not included)**

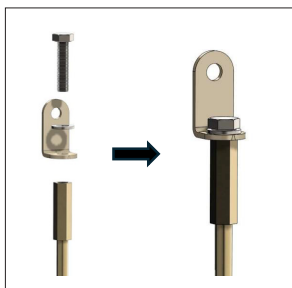

STEP 1

Use for Wooden Play set. (M8X40MM 4PCS)



STEP 2

Use for Metal Swing.
 (Item# Reference: LK29/LK30/LK28)
 (M6X50MM Bolt with Nylock Nuts)

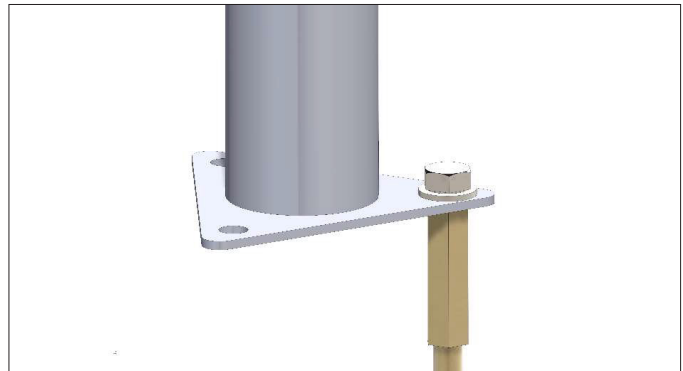

STEP 3

Use for JJ Series Play Centre.



STEP 4

Use for Kakadu Series
 (Item# Reference: LK98/LK99/LK100).

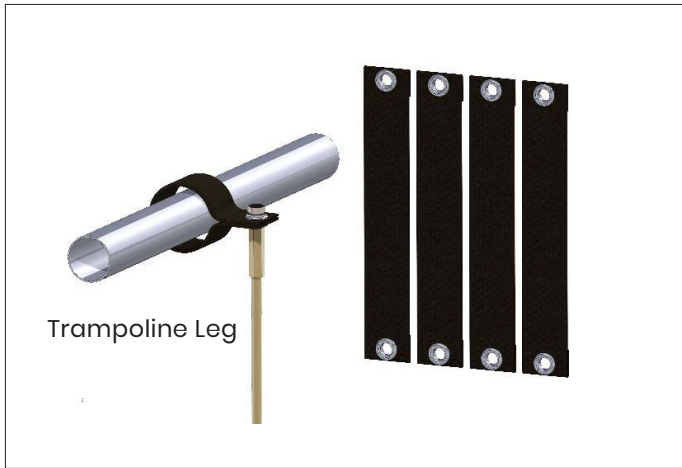

STEP 5

Use for Trampolines.



STEP 6

Other functions available For Dog Tie, Tent Stakes.

WARRANTY

AUSTRALIAN CONSUMER LAW

Many of our products come with a guarantee or warranty from the manufacturer. In addition, they come with guarantees that cannot be excluded under the Australian Consumer Law. You are entitled to a replacement or refund for a major failure and compensation for any other reasonably foreseeable loss or damage.

You are entitled to have the goods repaired or replaced if the goods fail to be of acceptable quality and the failure does not amount to a major failure. Full details of your consumer rights may be found at www.consumerlaw.gov.au.

Please visit our website to view our full warranty terms and conditions:

www.lifespankids.com.au/Warranty-Policy-Kids

WARRANTY AND SUPPORT

Any claim against this warranty must be made through your original place of purchase. Proof of purchase is required before a warranty claim may be processed. If you have purchased this product from the Official Lifespan Kids website, please visit www.lifespankids.com.au/warranty-form

For support outside of warranty, if you wish to purchase replacement parts or request a repair or service, please visit www.lifespankids.com.au/warranty-form and fill in our Repair/Service Request Form or Parts Purchase Form.

