

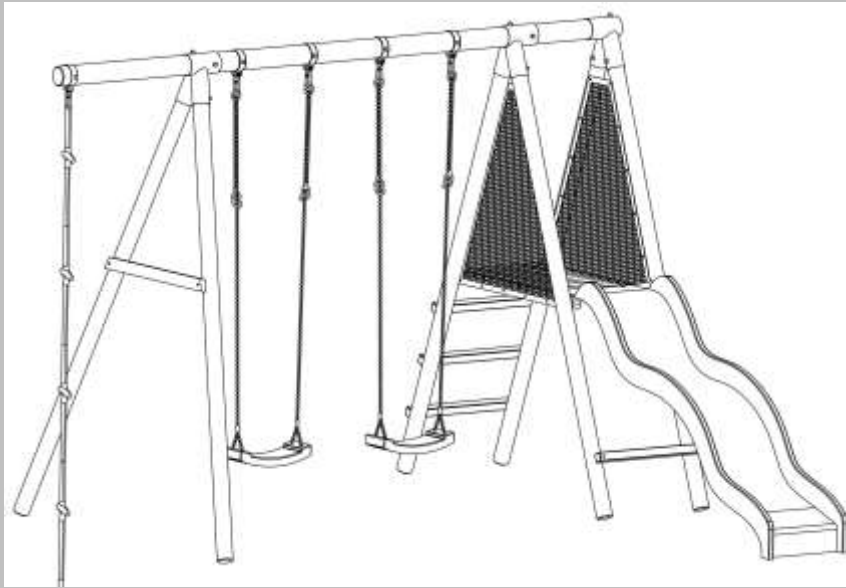

Monash swing set

ASSEMBLY INSTRUCTIONS



**For children ages 3-12
For outdoor domestic use only.**



- Not suitable for children under 36 months due to small parts, cords and the design of the product.
- Suffocation hazard: be careful of small detachable parts that may be swallowed.
- Important: These instructions must be followed for safe assembly and use. Please retain for future reference.

Components

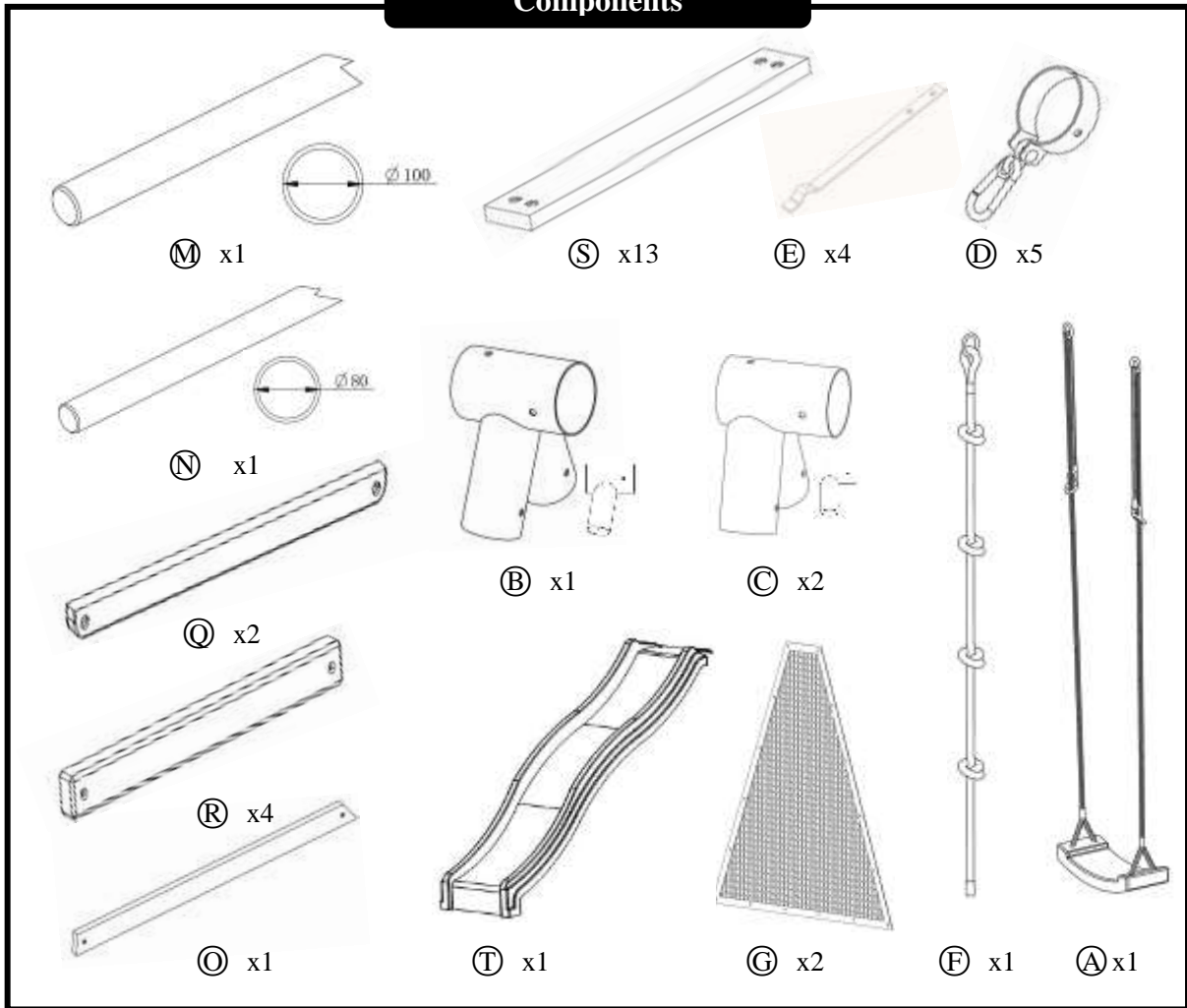

Fixings

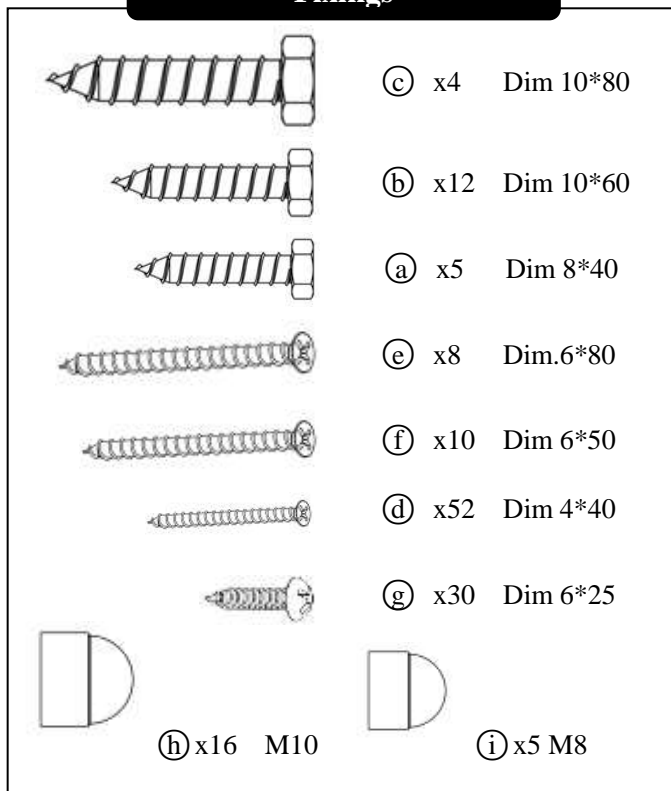

ASSEMBLY

3

TOOLS

- Drill / screw gun
- No. 17 wrench
- Hammer
- Level
- Shovel / pickaxe
- Tape measure

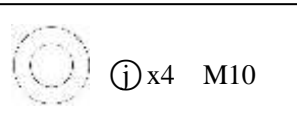

STEP 1

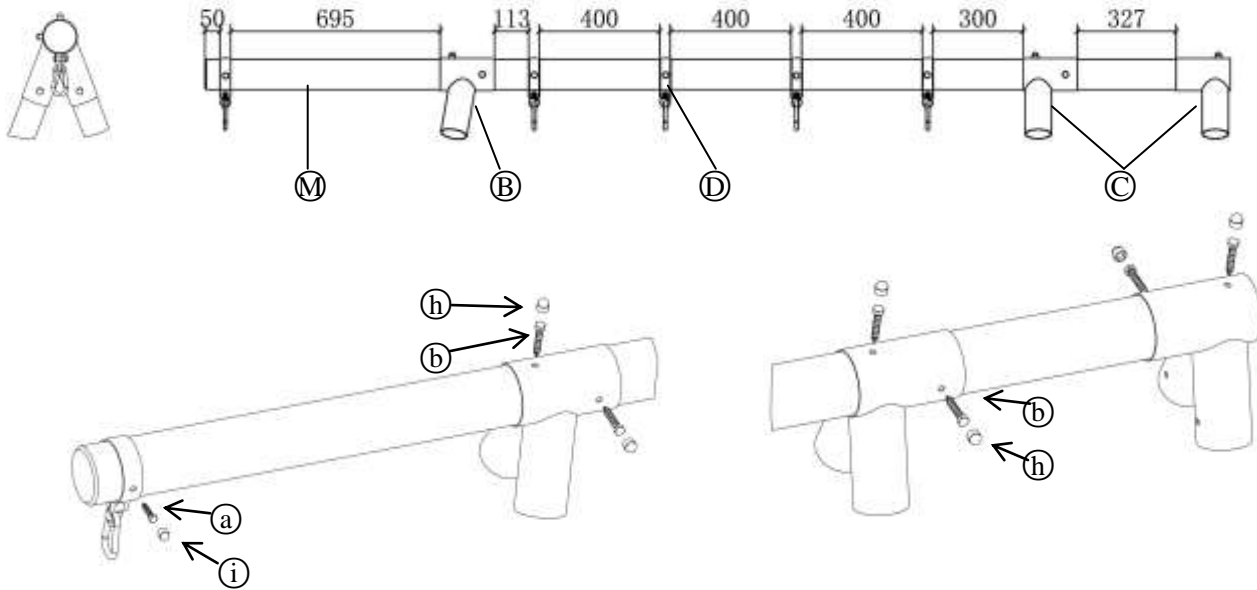

- You must comply with connector and ring position indications.
- Ensure that connectors **B** & **C** are correctly aligned.

STEP 2

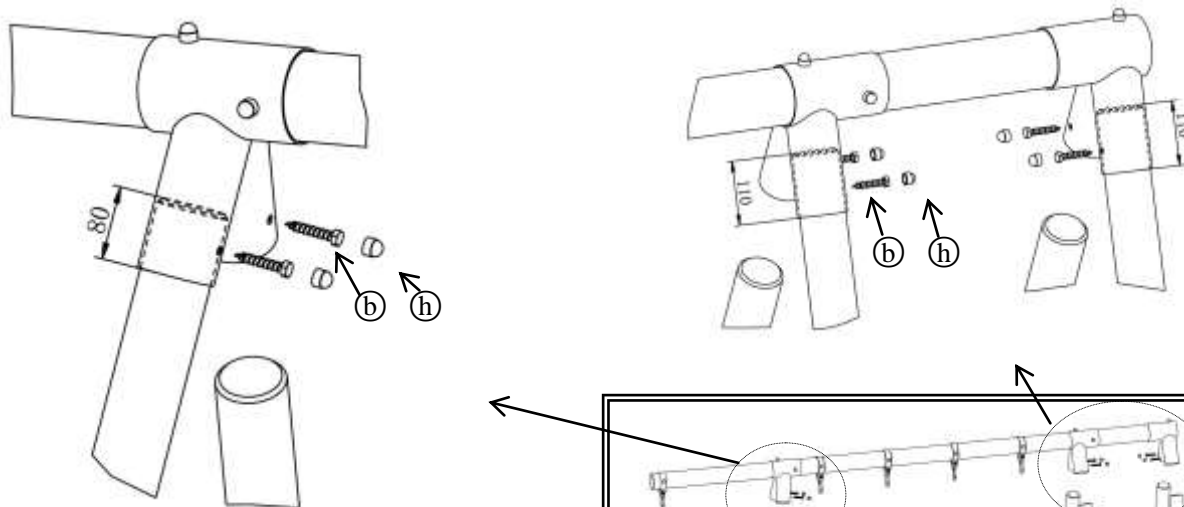

To ensure the swing frame's geometry is correct,
Please comply carefully with the depth indications
When placing the wooden posts in the connector.

It is best to place the swing frame and assemble it
on the ground.

You will be required to raise the product during
the next step

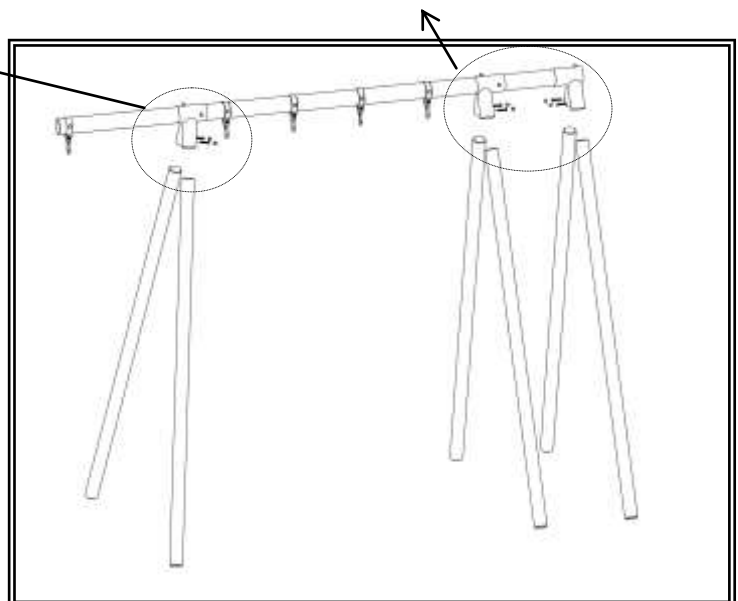

- Complete the screwing on the poles

STEP 3

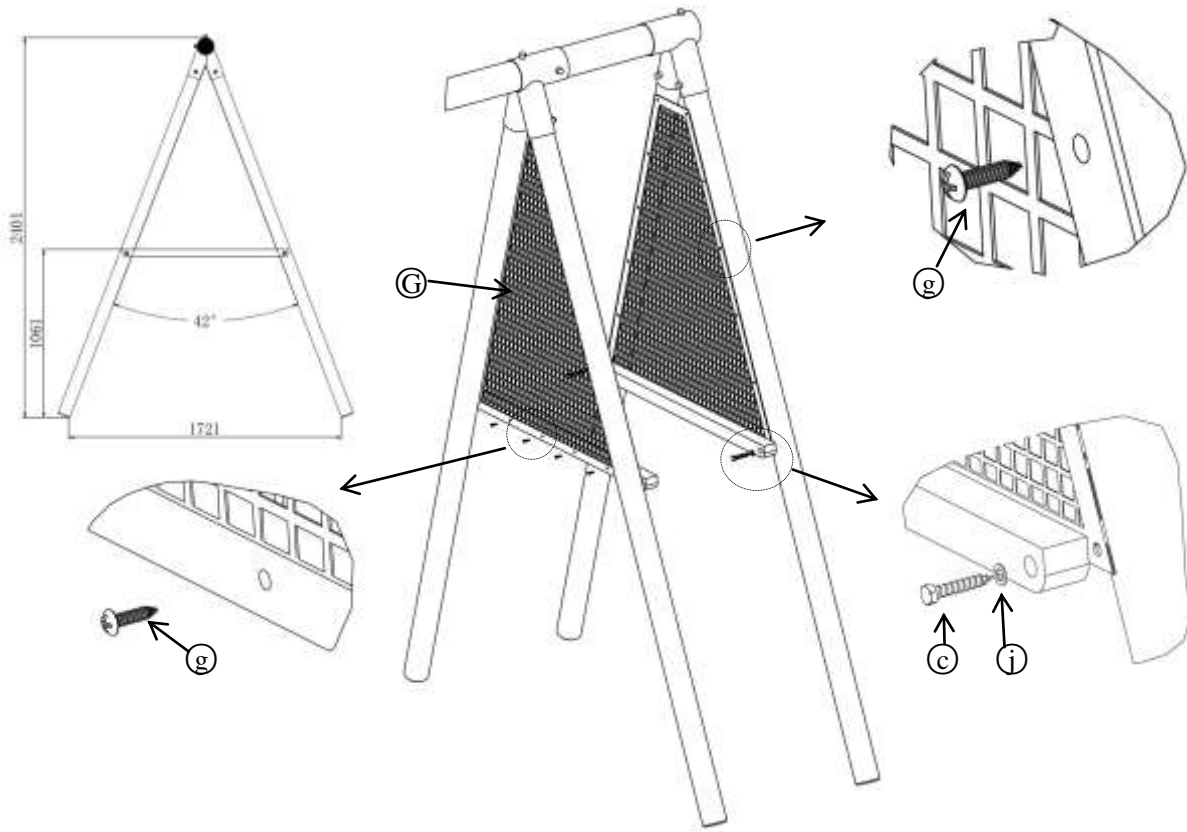

STEP 4

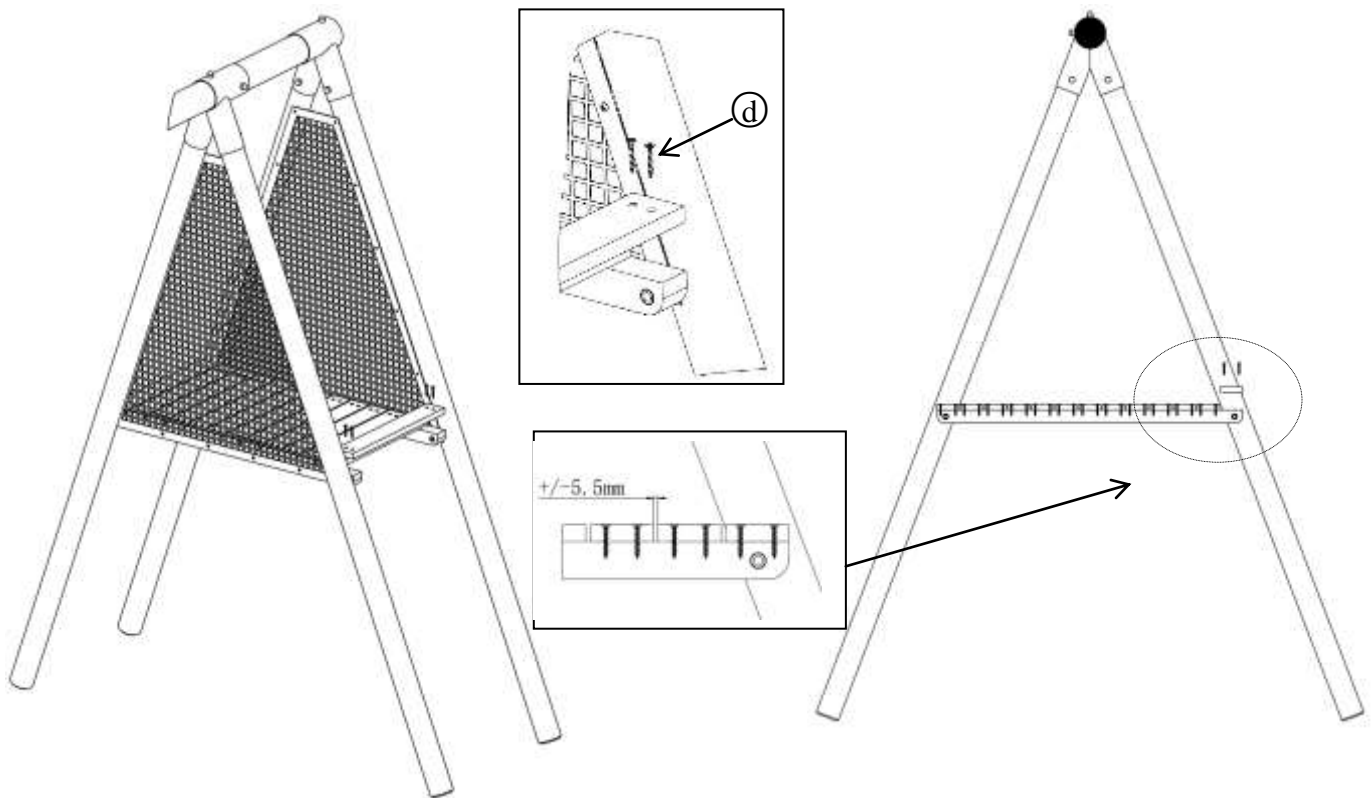

STEP 5

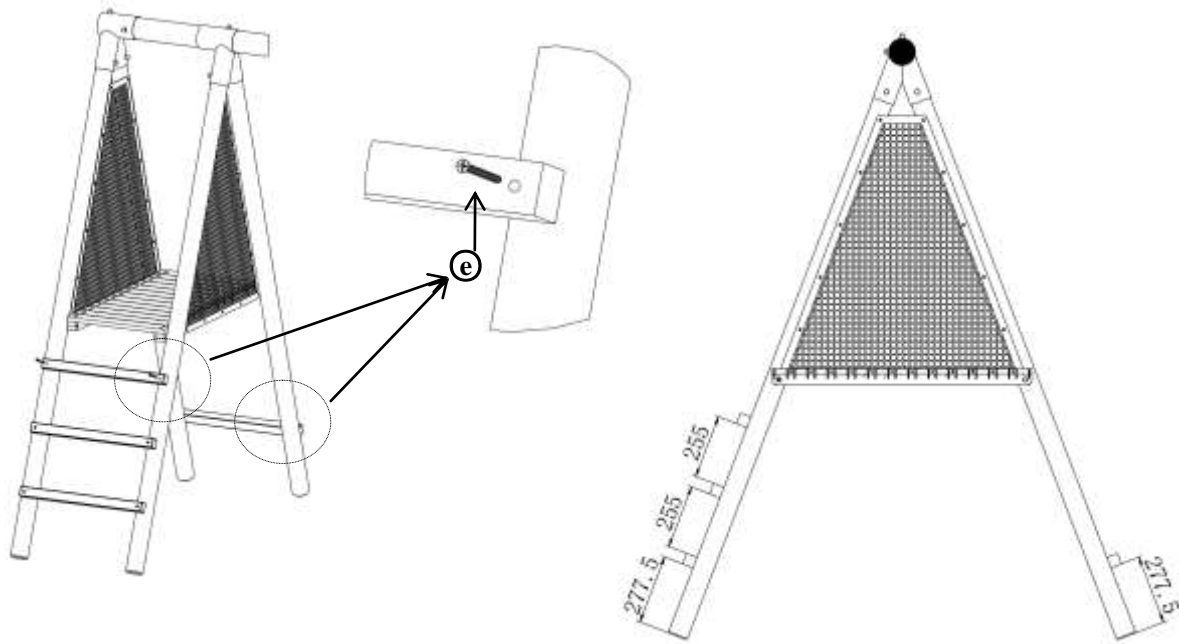

STEP 6

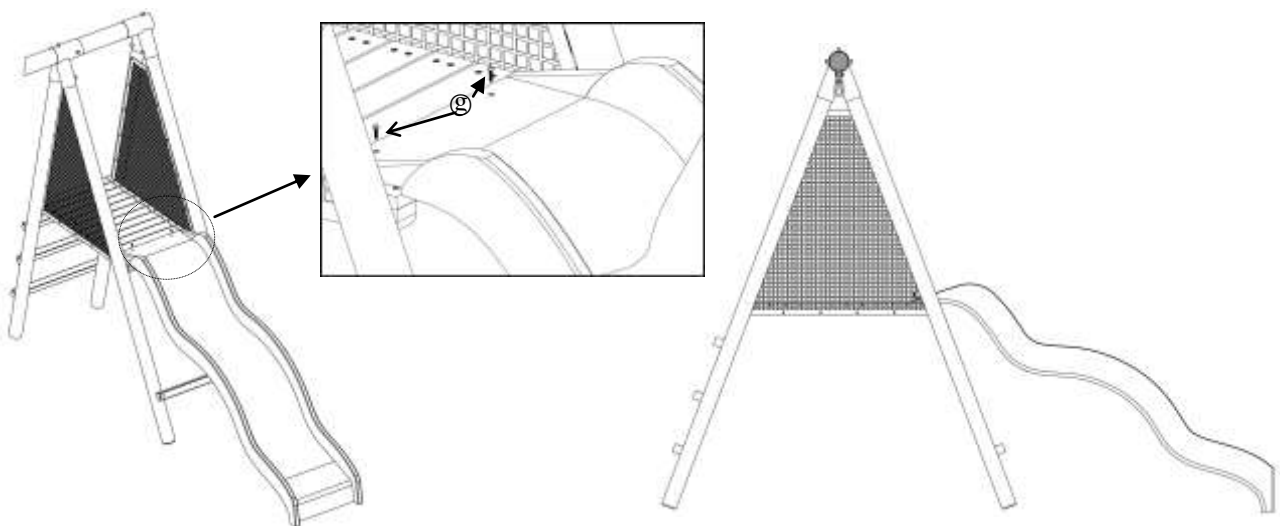

STEP 7

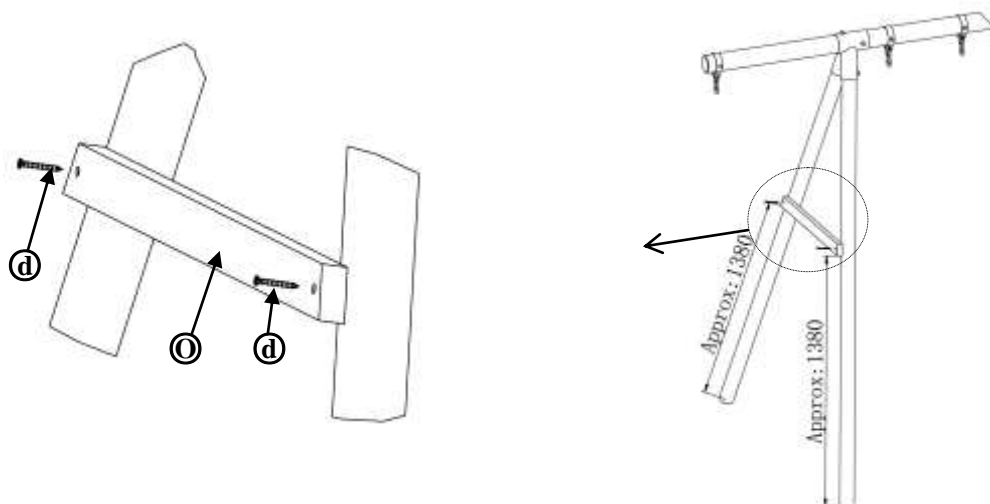

STEP 8

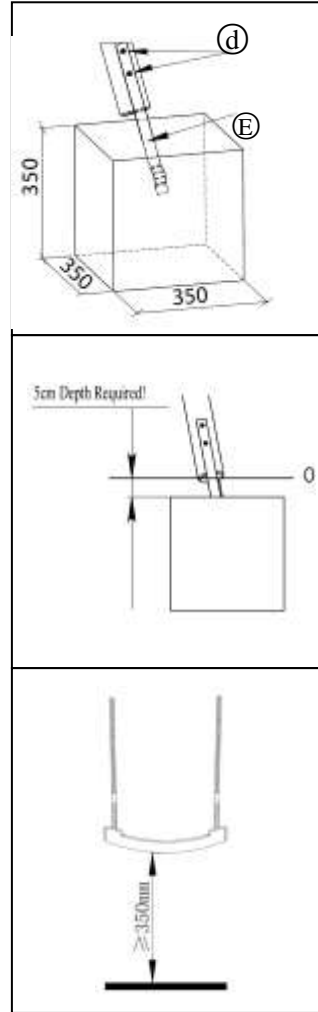
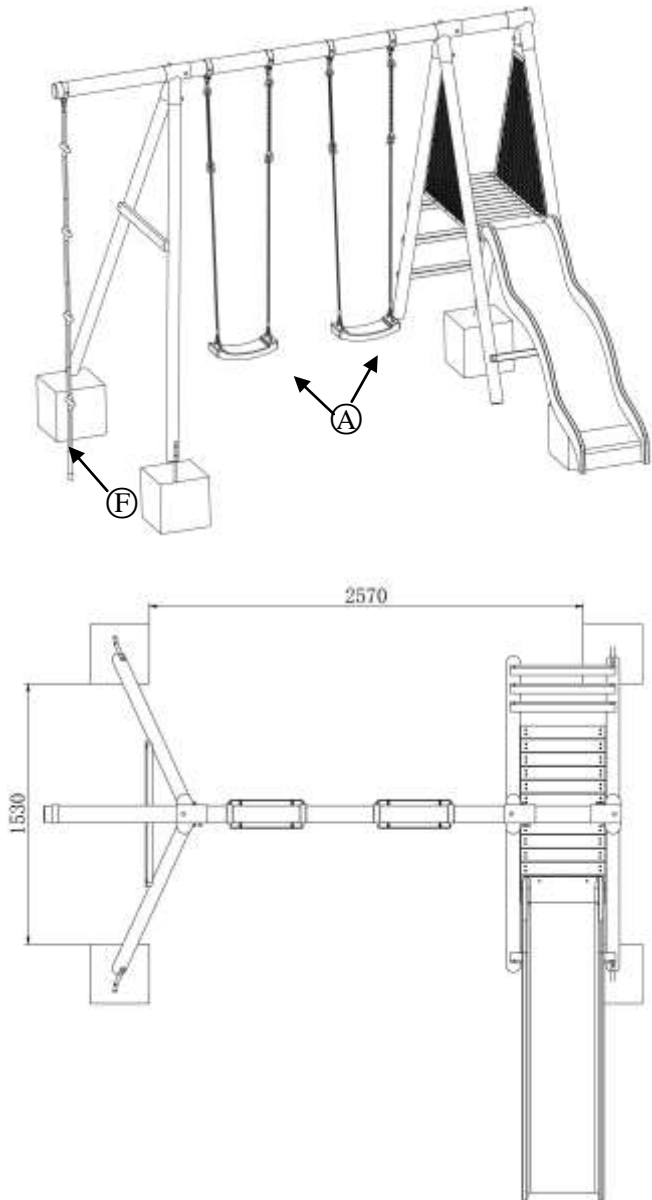

The distance from the ground to the swing element should be $\geq 350\text{mm}$

Safety Perimeter Diagram

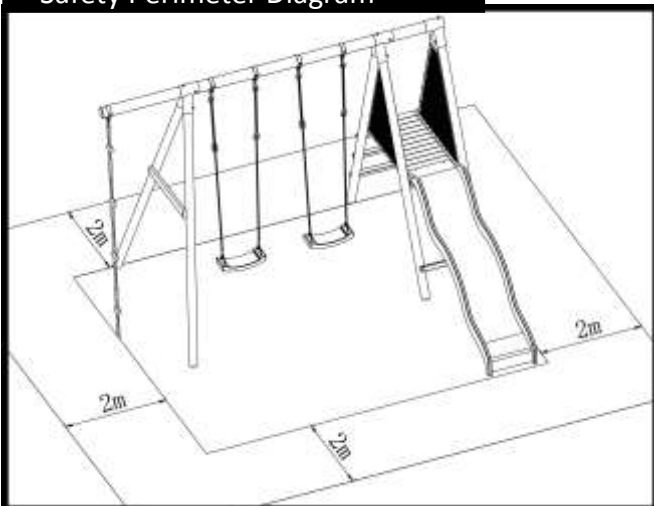

Recommended Safety Perimeter:

The safe play area refers to the zone extending 2m beyond the equipment on all sides and 700cm above the equipment. The safe area must be free from all structures, landscaping, trees and branches, rocks, wires, sprinkler heads and other similar obstacles which could obstruct safe play. Children can be seriously injured running or colliding into such obstacles.



- **SUFFOCATION HAZARD:** Be careful of small detachable parts that may be swallowed.
- This product is to be used domestically in an outdoor family environment.
- This equipment may not be used for collective and / or public purposes (playgrounds, camp grounds, schools, nursery schools, etc.)
- This item is designed for children ages 3 to 12 and must be used under adult supervision.

WOOD ADVICE:

Our product was manufactured from premium timber with great care dealt in selecting, machining and treating the timber before it is sold to you.

Bear in mind that timber is a natural product and may experience changes throughout the course of its life. It may:

- Develop openings (gaps, slits, apertures, cracks) along the line of the grain. This occurs due to moisture content between internal and outer surfaces of the timber. It is totally acceptable and will not affect the integral strength, life or guarantee of the product.
- Fade as the timber reacts with sunlight. The timber should be treated with a proprietary product to act as a protective barrier (i.e. a watery repellent on an annual basis)

ASSEMBLY:

Assembly must be performed by two adults.

During assembly, the short pieces of wood forming the base of the frame must be embedded 10 or 12 cm (depending on the connectors) before being attached with the coach screws.

ANCHORING

- Anchor kits provided, cement is not supplied.
- Minimum 5 cm depth below ground level of concrete anchoring is needed.

RECOMMENDATIONS:

The swing frame must be securely attached.

For safety reason, the cement cubes must be poured 5cm below ground level, at the frame's outer angles. The swing frame must not be installed on cement, asphalt, or any other hard surface.

Your swing frame must be attached on a flat horizontal surface with a minimum of 2m between it and any structure or obstacle such as a fence, garage house, tree branches, cloths lines, or electric cables.

USING YOUR EQUIPMENT:

Each of them is limited to 50kg in weight and must be used by one child at a time.

For swing frames equipped with a slide, avoid direct sun exposure in order to prevent risks of burns and ensure that the landing area is clear. To slide down the slide, children must be sitting with their feet forward.

During assembly and use, ensure that any splinters are removed.

MAINTENANCE:

We recommend regular maintenance should be conducted at the beginning of each season for your play equipment to ensure all main parts/fixings are tightly secured, well-oiled and intact to avoid injury or hazard.

Check the accessories monthly as well as the play equipment's structure in order to prevent falling risks.

Check and retighten screws, bolts and all other hardware elements as necessary, lubricate all moving metallic parts. For longer accessory life, we suggest storing them during the winter. When signs of oxidation and / or rust appear on various metallic parts of your equipment, fix or replace with the appropriate product.

Any original accessory must be replaced by a model with identical design and characteristics. If your play structure is disassembled, be sure to clearly mark the attached metal plates to prevent accidents. Check all bolt covers and sharp edges and replace them if necessary.

Please visit our website to view our full warranty terms and conditions:

[Http:// www.lifespanonline.com.au](http://www.lifespanonline.com.au)

Please read and retain these instructions

Global Fitness and Leisure Pty Ltd

17 Fordson Rd,

Campbellfield, VIC 3061

+61 3 9357 2166

info@lifespanfitness.com.au



Monash Swing set