



# Wallaby Cubby House

## PE11 Wallaby Cubby House Instructions



**WARNING!**  
Not suitable for children under 3 years until fully assembled. Small parts. Choking hazard.

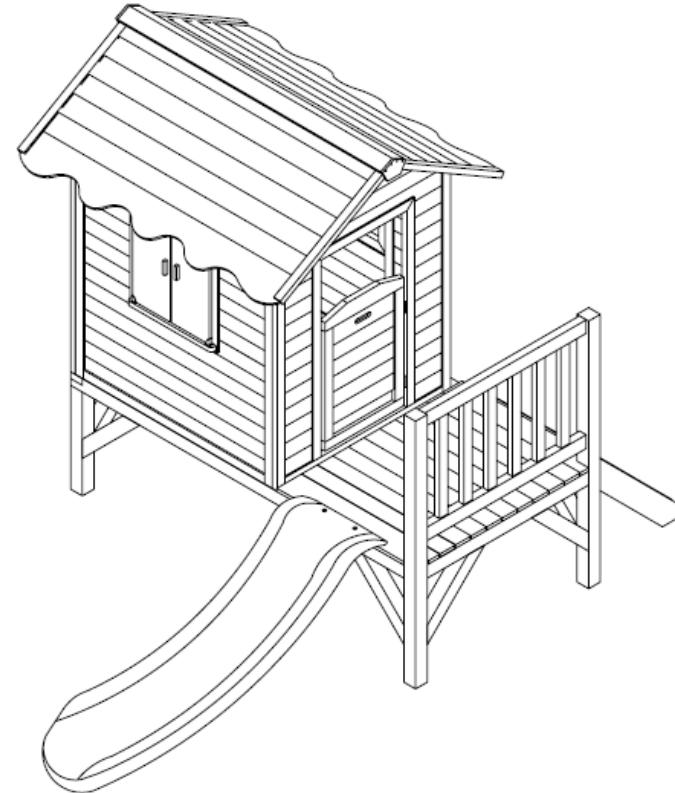

### Important

The owner's manual contains safety, assembly, use and maintenance instructions. The PRODUCT must be assembled by an adult who has read and understand these instructions. Keep the packaging away from children and dispose of all packaging before use. It is best to keep the instructions for future reference.

For the installer and your children's safety, it is important to fully read and understand the instructions and safety hazards before commencing the assembly of the product.

# Location and Placement

Proper placement and maintenance of protective surfacing is essential.

1. This product is safely designed only for domestic family use, outdoor use only and must not be installed within a public area such as a school, public house garden, community play area, etc.
2. This product requires anchoring in the ground with metal anchors that should be concreted in (concrete not supplied). The hole for the concrete should be made for each anchor point, and should be lower than ground surface to avoid tripping hazard. See Anchoring below for more details
3. Place within a clear area where the nearest obstruction (fence, tree laundry line, cable, etc.) is more than 2 metres away. This distance should be measured from the furthest point of the play set (i.e. tip of any slide)
4. Installation must be on a flat surface (slope less than 2-3%) otherwise there may be a risk of instability
5. Installation on a suitable surface (i.e. should not be installed over hard or broken surfaces such as concrete, asphalt, tarmac etc.)
6. It may be appropriate to ensure that the slide chute is not facing the main direction of the sun to prevent the slide chute being uncomfortably hot to play in.

# Safety

- ⚠ Only adults should assemble or disassemble this product. This product must be anchored.
- ⚠ This product is safely designed for children between the ages of 3 years to 12 years old while being supervised by a responsible adult.
- ⚠ Adult supervision of children is required at all times when on or around this product. We advise that parents should observe and ensure that their children have the strength and skills to enjoy all the equipment safely before using them on their own.
- ⚠ To prevent serious injury do not allow children to play on the product until it is completely assembled and installed.
- ⚠ Children using this product should only use the product in the manner intended. i.e. do not allow children to climb onto items not designed for that purpose, as injuries may result.
- ⚠ Equipment may be slippery when wet. Do not allow children to use the equipment when wet.
- ⚠ Never attach any materials that are not specifically designed for use with this product, such as jump ropes, pet leashes, rope or cords and other chains as these pose a potential strangulation hazard.
- ⚠ Parents should regularly check openings and surfaces, such as slides for items that may be hazardous.

# Anchoring

Anchoring is necessary to prevent tipping, lifting, and overturning. The product is recommended to be anchored in concrete, especially when assembled on soft or sandy soil.

To anchor the product in concrete, dig a hole at least 5" (12.7cm) deep and 10" (25.4cm) to 12" (30.5cm) in diameter. Place each leg in the prepared hole, preferably on a brick or stone to keep it from sinking. Pour concrete around the legs and fill the hole. Allow the concrete to cure according to the concrete manufacturer's instruction before use.

# Timber

This product is made with timber gathered from FSC® well managed forests. See [www.fsc.org](http://www.fsc.org) for more details.

Our product was manufactured from premium timber with great care dealt in selecting, machining and treating the timber before it is sold to you.

Bear in mind that timber is a natural product and may experience changes throughout the course of its life. It may:

- Develop openings (gaps, slits, apertures, cracks) along the line of the grain. This occurs due to moisture content between internal and outer surfaces of the timber. It is totally acceptable and will not affect the integral strength, life or guarantee of the product.

- Fade as the timber reacts with sunlight. The timber should be treated with a proprietary product to act as a protective barrier (i.e. a watery repellent on an annual basis)
- Warp and distort its shape. Any distortion will be slight and will not affect the safety or enjoyment of this product.

# Assembly

This product contains pre-assembled parts for easier assembly.



Only adults should assemble or disassemble the product.



For safety reasons and ease of assembly it is recommended that **two** adults assemble the product.



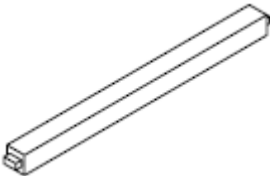
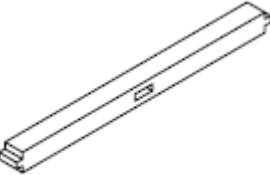

This product should be assembled near the location where it will be permanently anchored.

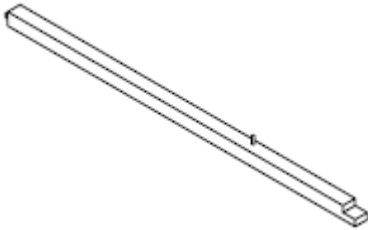
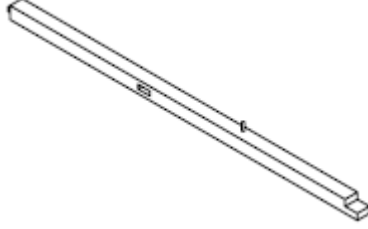
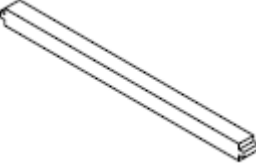
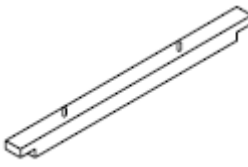

**See below for Parts and Assembly instructions**

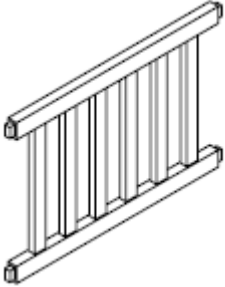



# Parts

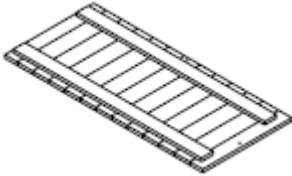
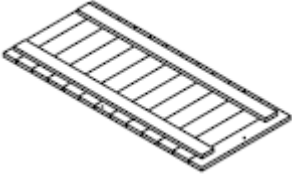
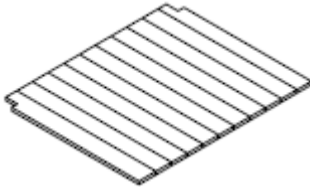



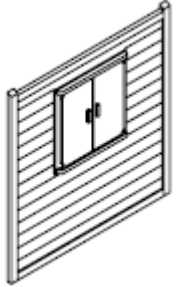

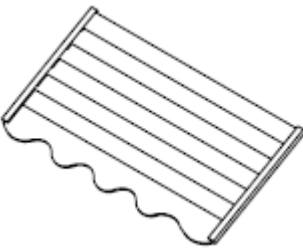
Number	Parts	Quantity
1		1x
2		1x
3		1x
4		1x

5		1x
6		1x
7		1x
8		1x
9		2x

10		1x
11		8x
12		1x
13		3x
14		1x

15		1x
16		1x
17		1x
18		1x

19		2x
20		1x
21		2x
22		1x
A	 3mm x 35mm	6x

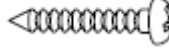
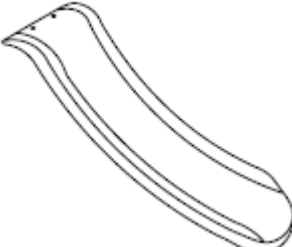
B	 3.5mm x 35mm	17x
C	 3.5mm x 40mm	20x
D	 3.5mm x 45mm	12x
E	 3.5mm x 50mm	4x
F	 4mm x 60mm	27x
G	 5mm x 70mm	28x
H	 6mm x 40mm	2x
I		1x

# Instructions

1.

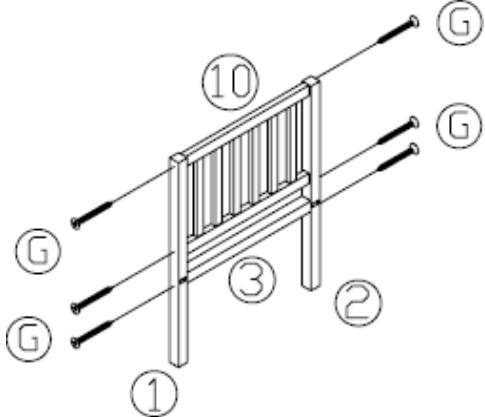

2.

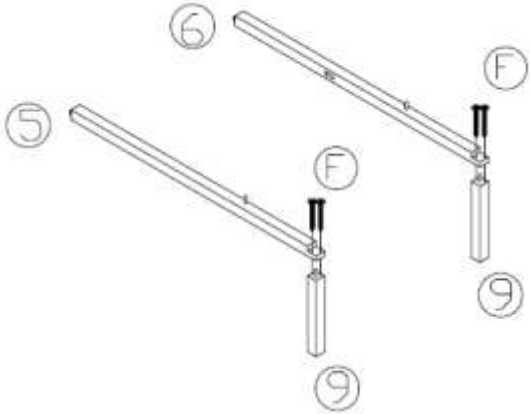

3.

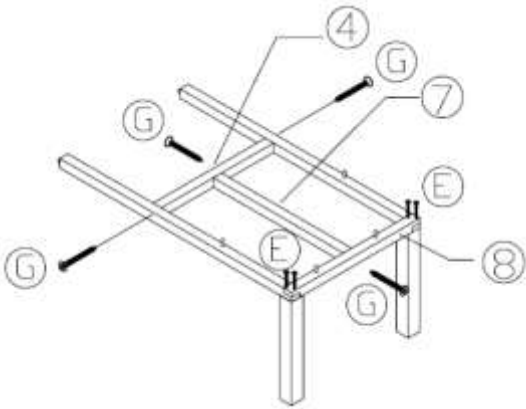

4.

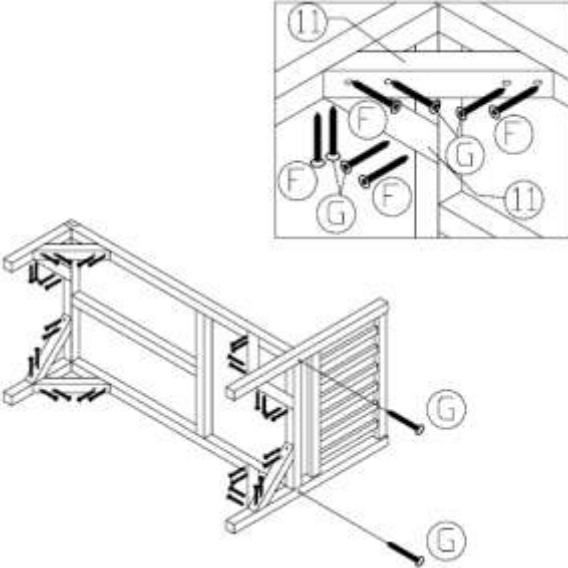

5.

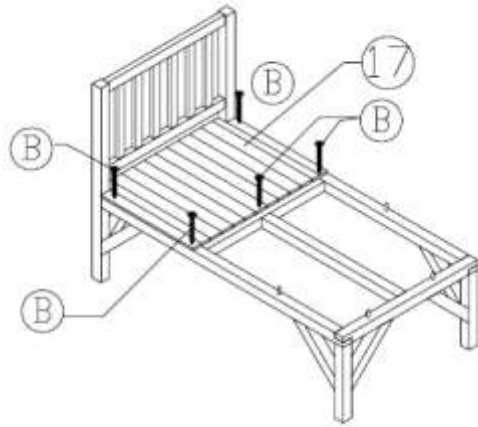

6.

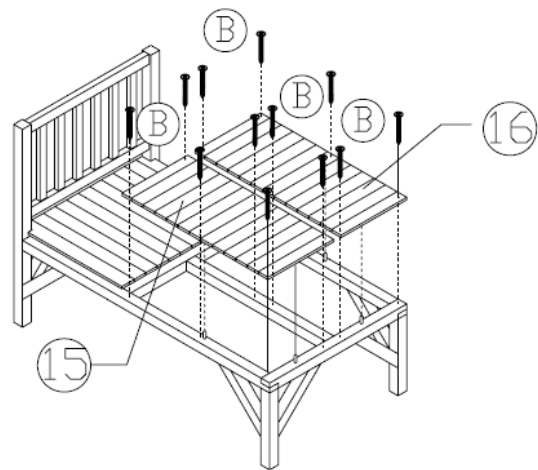

7.

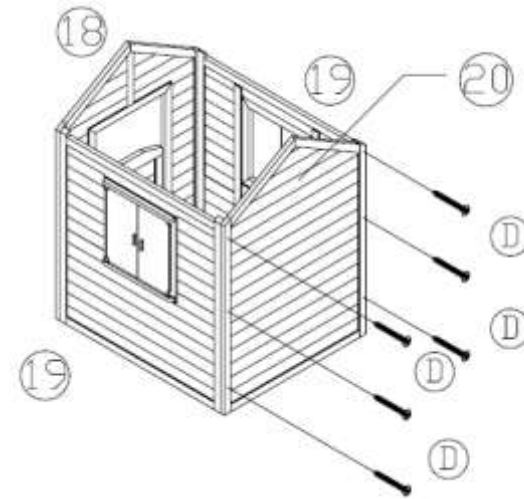

8.

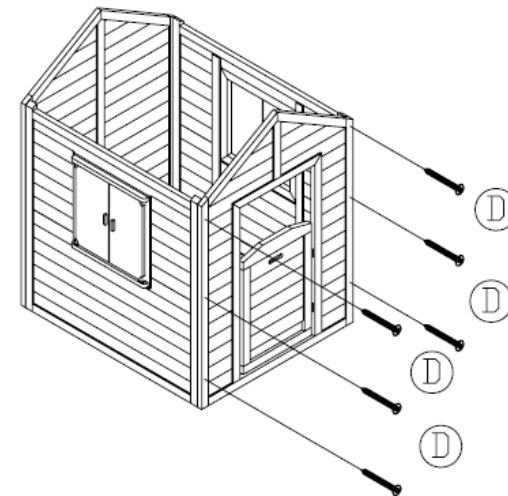



9.

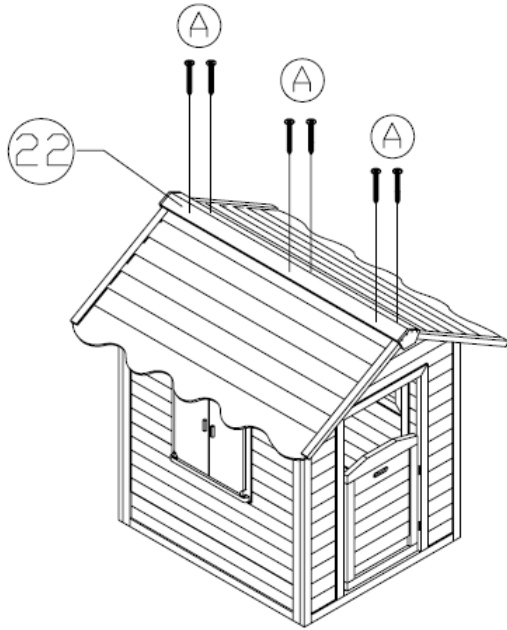

10.

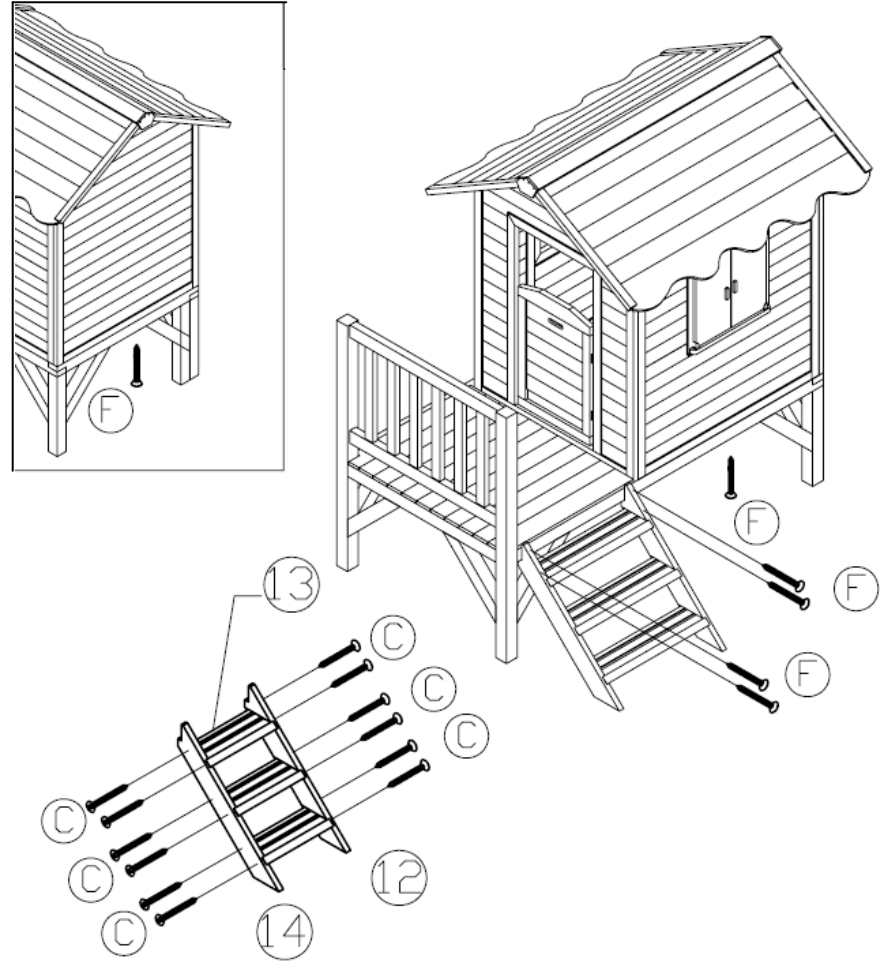

11.

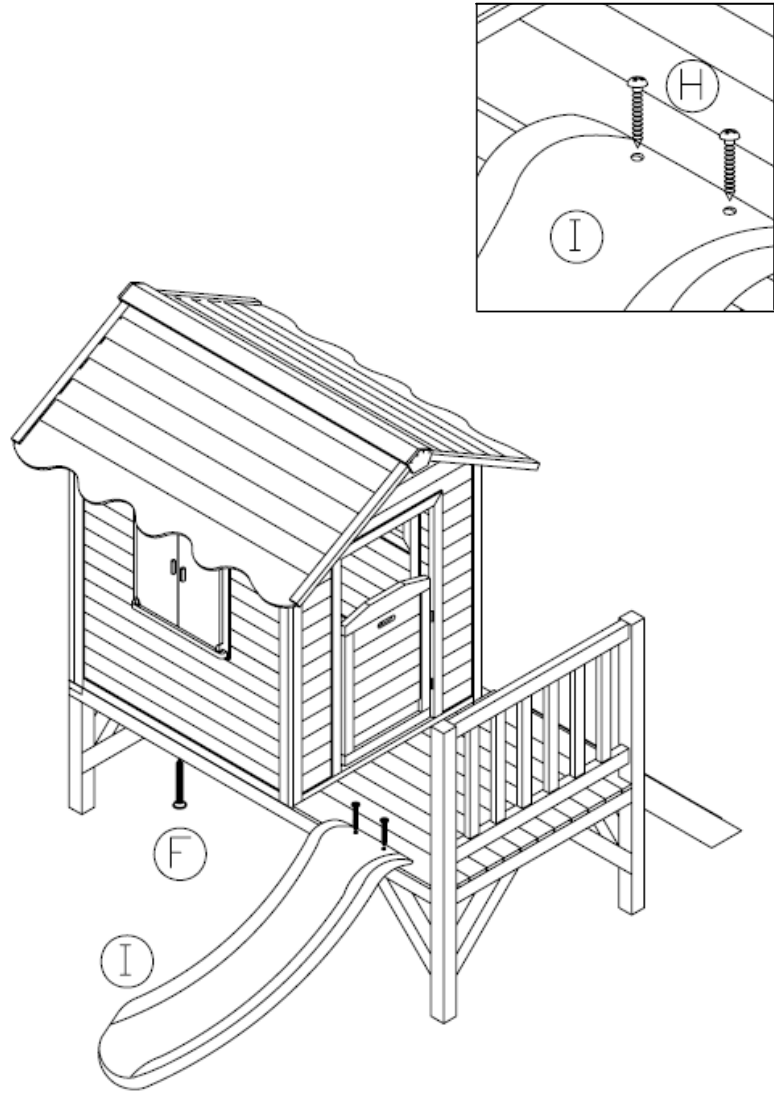

# Care and Maintenance

We recommend regular maintenance should be conducted at the beginning of each season for your play equipment to ensure all main parts/fixings are tightly secured, well-oiled and intact to avoid injury or hazard.

We advise the following tips:

1. Tighten all hardware.
2. Lubricate all metallic moving parts
3. Check all protective coverings on bolts, pipes, edges and corners. Replace if they are loose, cracked or missing
4. Check metal parts for rust. Replace as needed
5. Prevent weathering by applying protective barriers to your timber via proprietary products to maintain its quality.
6. Attachments such as chains, ropes, swings must be regularly examined for evidence of deterioration. Replace any attachments if there are signs of deterioration.

# Warranty

## AUSTRALIAN CONSUMER LAW

Many of our products come with a guarantee or warranty from the manufacturer. In addition, they come with guarantees that cannot be excluded under the Australian Consumer law. You are entitled to a replacement or refund for a major failure and compensation for any other reasonably foreseeable loss or damage.

You are entitled to have the goods repaired or replaced if the goods fail to be of acceptable quality and the failure does not amount to a major failure. Full details of your consumer rights may be found at [www.consumerlaw.gov.au](http://www.consumerlaw.gov.au)

Please visit our website to view our full warranty terms and conditions:

<http://www.lifespanonline.com.au/Warranty-Policy>

# Contact us

Please visit our website at: [www.lifespanonline.com.au](http://www.lifespanonline.com.au)

Email us at: [info@lifespanfitness.com.au](mailto:info@lifespanfitness.com.au)

This manual may be subject to change. Please view our website [www.lifespanonline.com.au](http://www.lifespanonline.com.au) for the most recent version of this manual

