

Basketball Bracket Installation Instructions

WARNING!

The disassembled item contains small parts which pose a choking hazard to children under 3.

Purpose

This part and is intended for the attachment of the Swish basketball ring to the Hurley metal swing set.

Parts List

1pc Bracket

Tool Requirements

1. 10mm Spanner
2. 6mm Allen key flat head screwdriver
3. Gloves (recommended for safety)



Installation

Step 1: Remove the end cap and unfasten one bolt. (Refer to Figure 2)

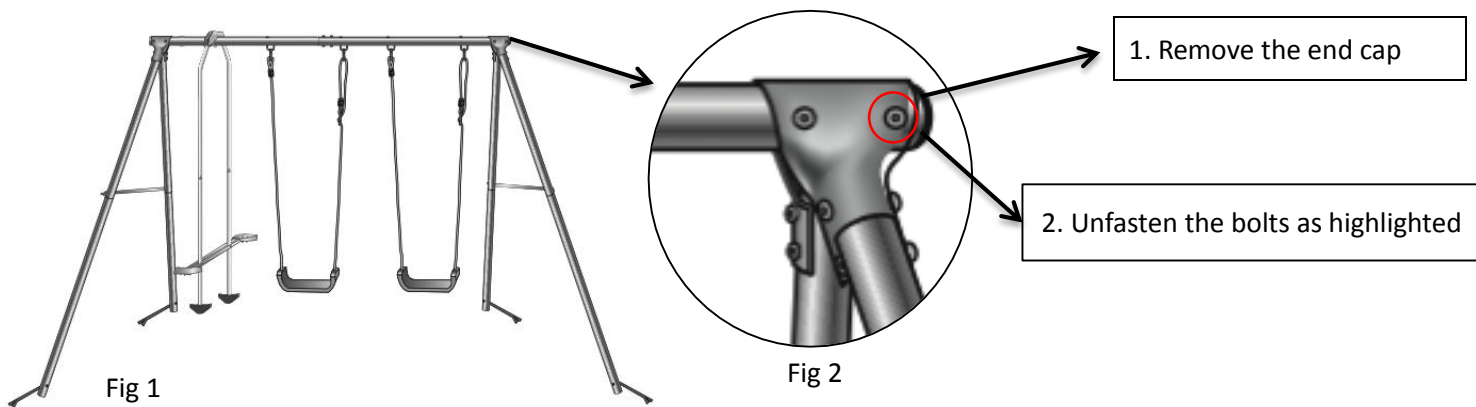

Step 2: Insert the bracket into the end of swing frame (fig 3). Then use the previous bolt to fit and tighten the nut properly.

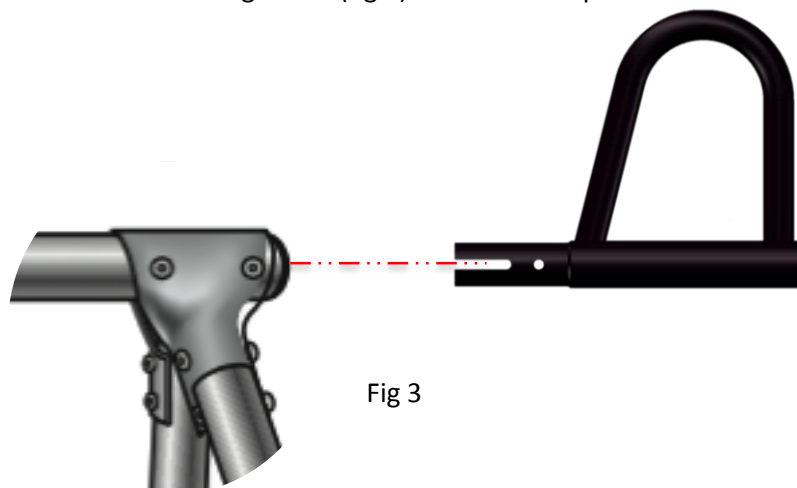

Step 3: Refer to the instructions supplied with basketball ring to complete assembly.



Fig 4



Fig 5



Fig 6

Warranty

AUSTRALIAN CONSUMER LAW

Many of our products come with a guarantee or warranty from the manufacturer. In addition, they come with guarantees that cannot be excluded under the Australian Consumer law. You are entitled to a replacement or refund for a major failure and compensation for any other reasonably foreseeable loss or damage.

You are entitled to have the goods repaired or replaced if the goods fail to be of acceptable quality and the failure does not amount to a major failure. Full details of your consumer rights may be found at www.consumerlaw.gov.au

Please visit our website to view our full warranty terms and conditions:

<http://www.lifespankids.com.au/Warranty-Policy-Kids>

Please send all warranty and support inquiries through our ticketing system via the email address:

support@lifespankids.com.au.

