

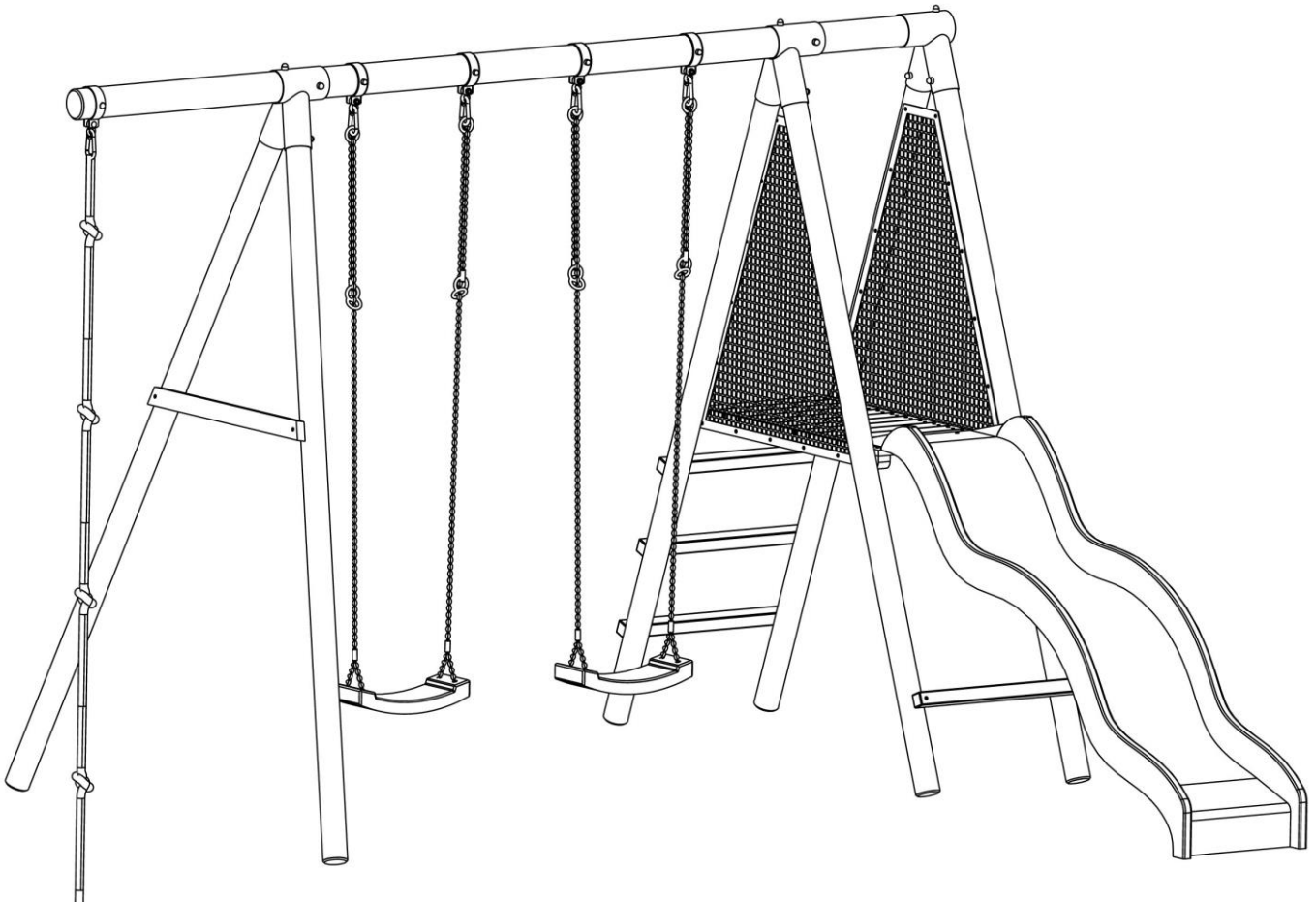

PE23 MONASH DOUBLE SWING OWNER'S MANUAL



- Not suitable for children under 36 months due to small parts, cords and the design of the product.
- For children ages 3-12 and must be used under adult supervision.
- **SUFFOCATION HAZARD:** be careful of small detachable parts that may be swallowed.
- Keep the packaging away from children and dispose of all packaging before use.
- This owner's manual contains safety, assembly, use and maintenance instructions. Retain for future reference.
- The product must be assembled by an adult who has read and understood these instructions.

GENERAL SAFETY INSTRUCTIONS

PURPOSE

This product is intended for outdoor, domestic use only. It is not suitable for commercial or medical use.

Weight Limit: 50kg per swing, 50kg on platform

DANGER FOR CHILDREN

- **WARNING! No eating while using the product**
- This product may only be used with adult supervision at all times.
- The packaging material is not suitable for children due to choking and suffocation hazards.

RISK OF INJURIES

- Do not use the product if it is damaged or defective. If it is damaged or defective, please contact a qualified technician.
- Check the product before each use. Defective parts must be changed immediately as they can impair the function and the safety of the product.
- No more than one person per swing or per attachment.
- Use the product only on even and non-slipping surfaces. Never use it near water and keep sufficient space around for safety.

PRODUCT DAMAGE

- Do not make alterations to the product. Only use original spare parts. Qualified technicians should only carry out repairs – improper repairs can lead to danger for the user. Use this product only as described in this manual.
- Protect the product against splashes, humidity, high temperature and direct sunlight.

ASSEMBLY ADVICE

- The assembly of the product must be done carefully and by an able-bodied adult. If in any doubt, ask a technically qualified person.
- Before you start with the assembly, read the instructions carefully.
- Remove all packaging materials and lay down all parts on an open space. This gives you an overview and simplifies the assembly procedure.
- Check with the parts list that all parts are available. Dispose of the packaging material when the assembly is completed.
- Beware that when using tools or doing technical work, there is always a risk of injuries. Assemble the product with care.
- Create a danger free environment; for example, do not let tools lay around the workspace. Store the packaging material in a way that cannot cause any danger.
- After installing the product according to the instruction manual, ensure all screws, bolts and nuts are correctly installed and tightened and that all joints are secure.
- Reasonable space must be kept between the product and possible sources of danger, such as other equipment swimming pools and fences.
- The product must be assembled correctly before use.
- Place the product on a level surface at least 2 m from any structure or obstruction such as a fence, garage or house.
- No modifications are to be made to the original product.

- The product must always be used in a well-lit area.
- Do not place anything under the product.
- Use gloves during assembly and disassembly.
- Outdoor products should be equipped with a device that in strong wind conditions avoid displacement due to wind (e.g. steel bars in the ground or loads like sand bag or water bags).
- In certain areas during winter, snow buildup and the low temperatures can damage the product. It is recommended to remove snow buildup and to store the product indoor.
- We strongly recommend visual inspections every 3 months to insure the integrity of the entire product. Replace any parts as necessary.

SAFETY INSTRUCTIONS

- The safety instructions of the product should always be considered and obeyed.
- Using the product may result in permanent injury such as paralysis, or even death. Falling off the product may lead to injuries, particularly to the back, neck or head.
- No clothes with hooks or loose parts should be worn or carried during product usage in order to avoid hooks getting caught and causing injury.
- Moving the product whilst assembled may affect the integrity of the frame. Should it be necessary to move the product, please consider the following:
 - 1.) Force to be evenly spaced around the frame to lift the product off the ground
 - 2.) The product must be carried horizontally
 - 3.) Use caution whilst moving as it could bend the product frame.
- Users should be familiar with the assembly manual. This manual contains assembly guidance; selected precautionary measures as well as recommendations for servicing and maintenance of the product, in order to ensure safe and fun usage.
- It is the responsibility of the owner or the supervisor to guarantee that all users of the product are informed sufficiently of all warning references and safety instructions.

For the supervisor:

The supervisor's role is to make sure users are aware of all safety precautions and that these precautions are enforced. When a supervisor is not available, the product may be disassembled or covered to limit access.

- The product can be only used if it is in good condition, worn or damaged parts should be replaced.
- Objects, which could be dangerous to the user, should be away from the product
- Avoid unauthorized and unsupervised use of the product.
- Do not use the product under influence of alcohol or drugs (incl. medicines).
- Do not use the product or its attachments as a jumping platform.

Components

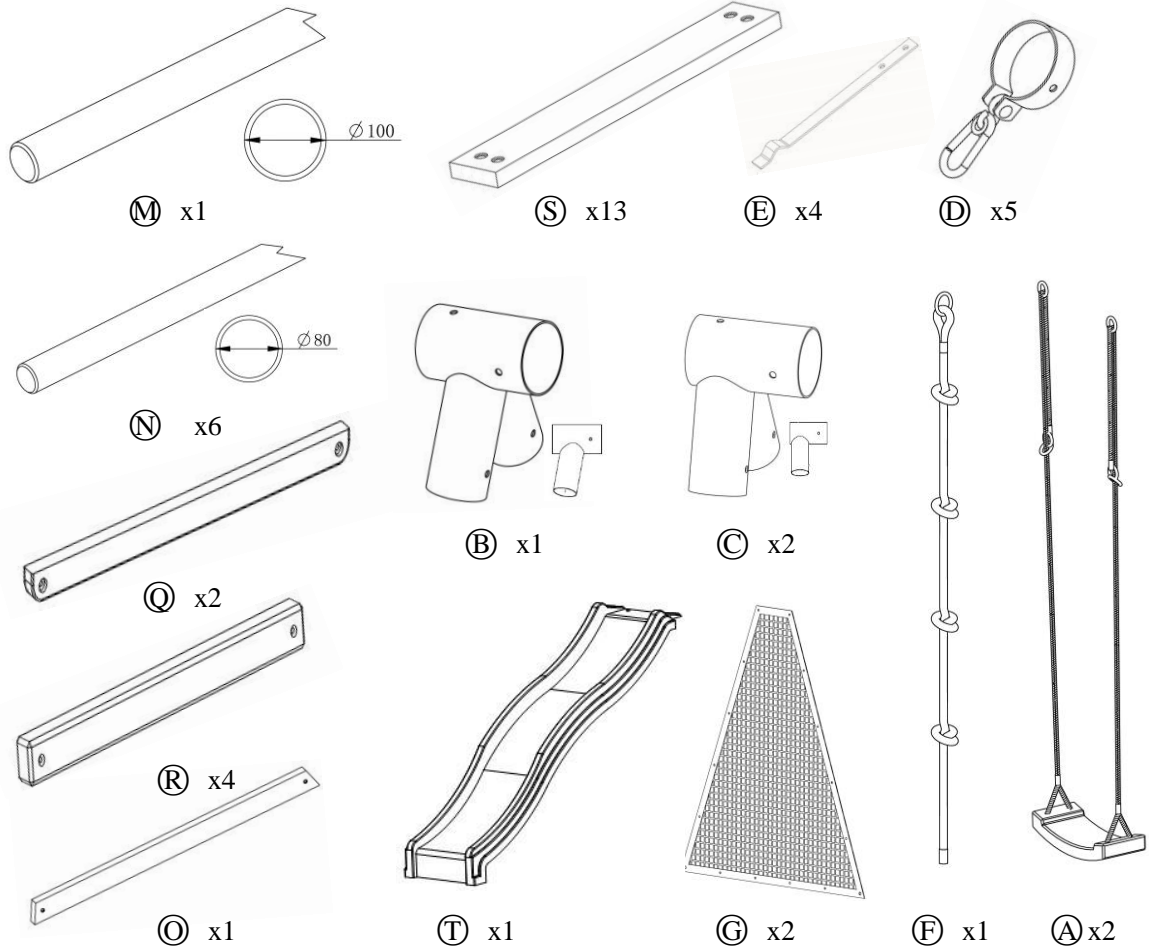

Fixings

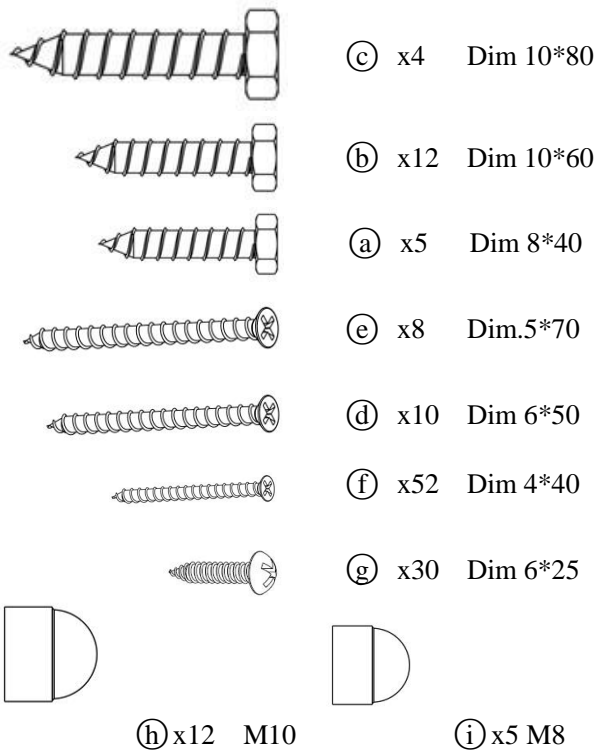

ASSEMBLY



5^{H00}



TOOLS

- Drill / screw gun
- No. 17 wrench
- Hammer
- Level
- Shovel / pickaxe
- Tape measure

STEP 1

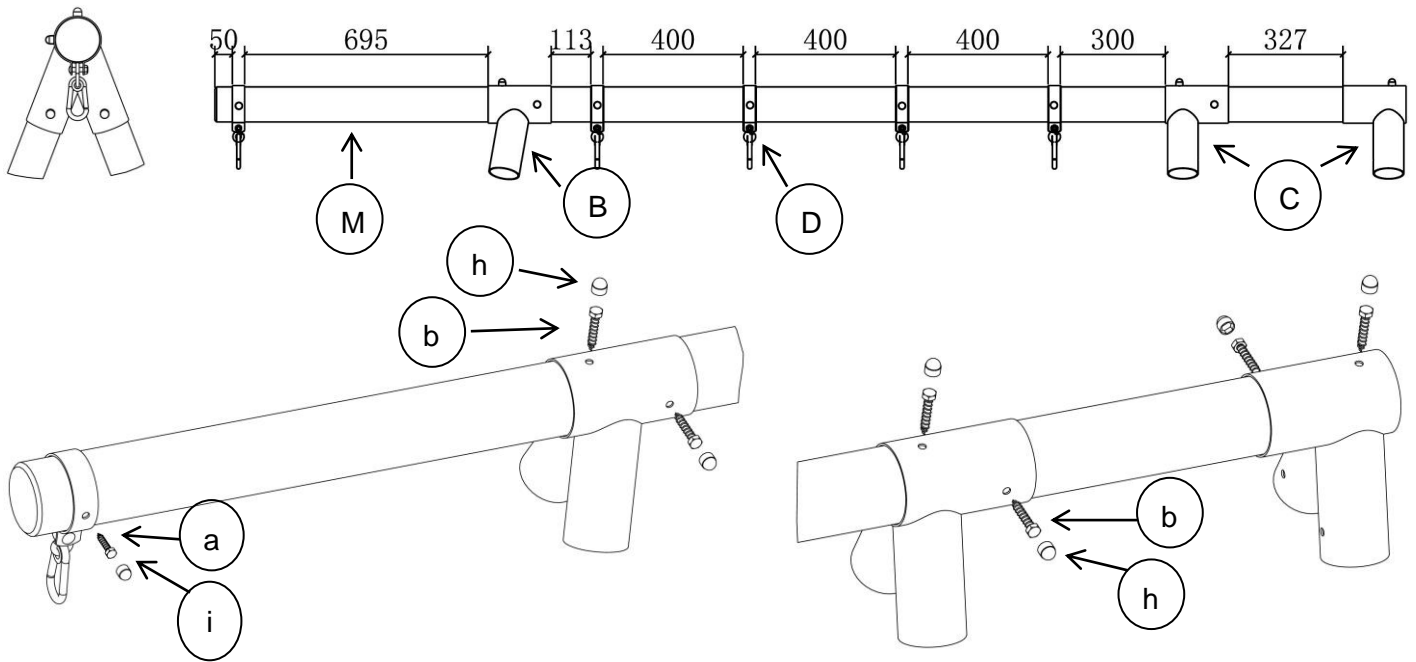

- You must comply with connector and ring position indications.
- Ensure that connectors B and C are correctly aligned.

STEP 2

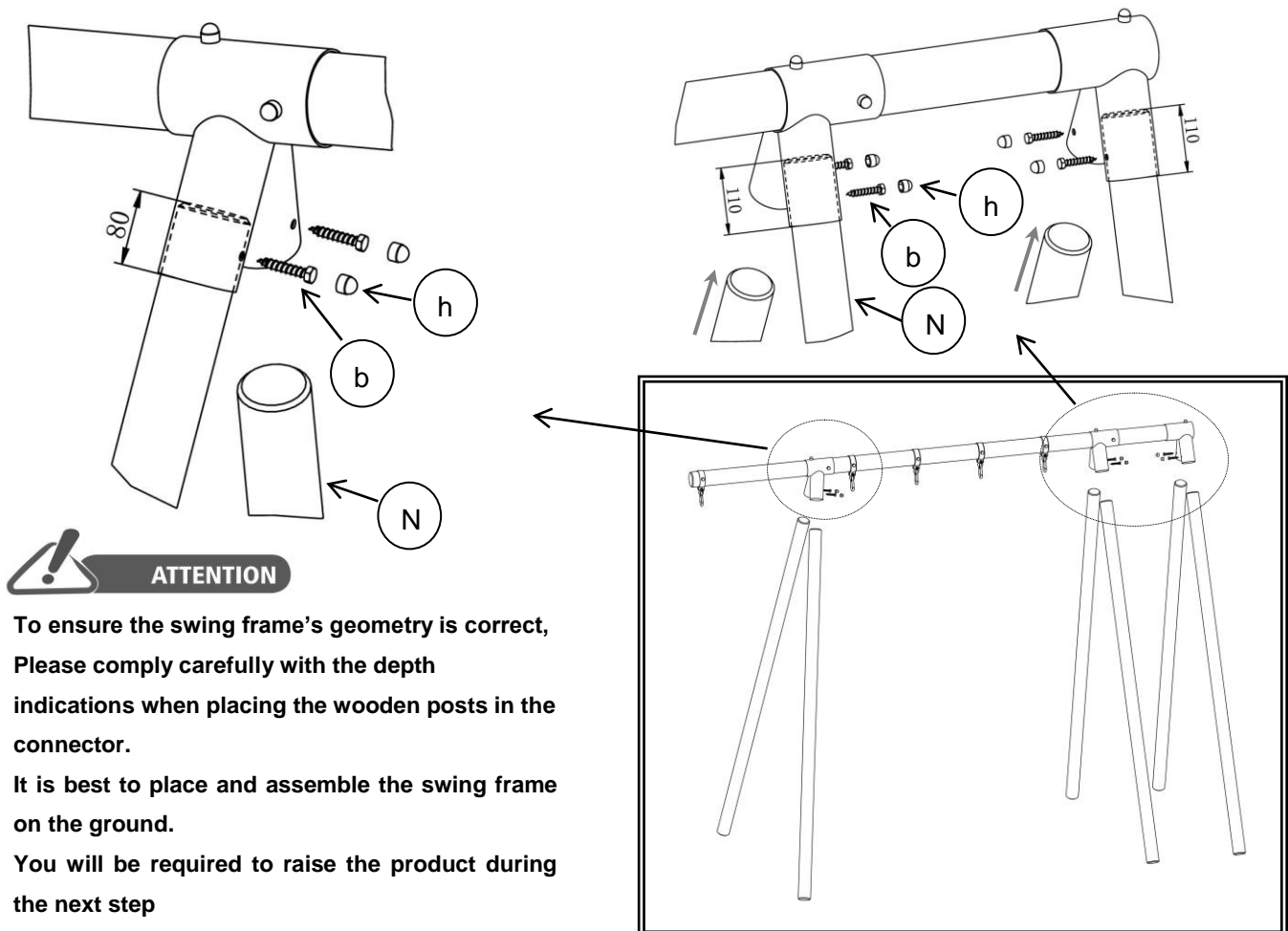

ATTENTION

To ensure the swing frame's geometry is correct, Please comply carefully with the depth indications when placing the wooden posts in the connector.

It is best to place and assemble the swing frame on the ground.

You will be required to raise the product during the next step

STEP 3

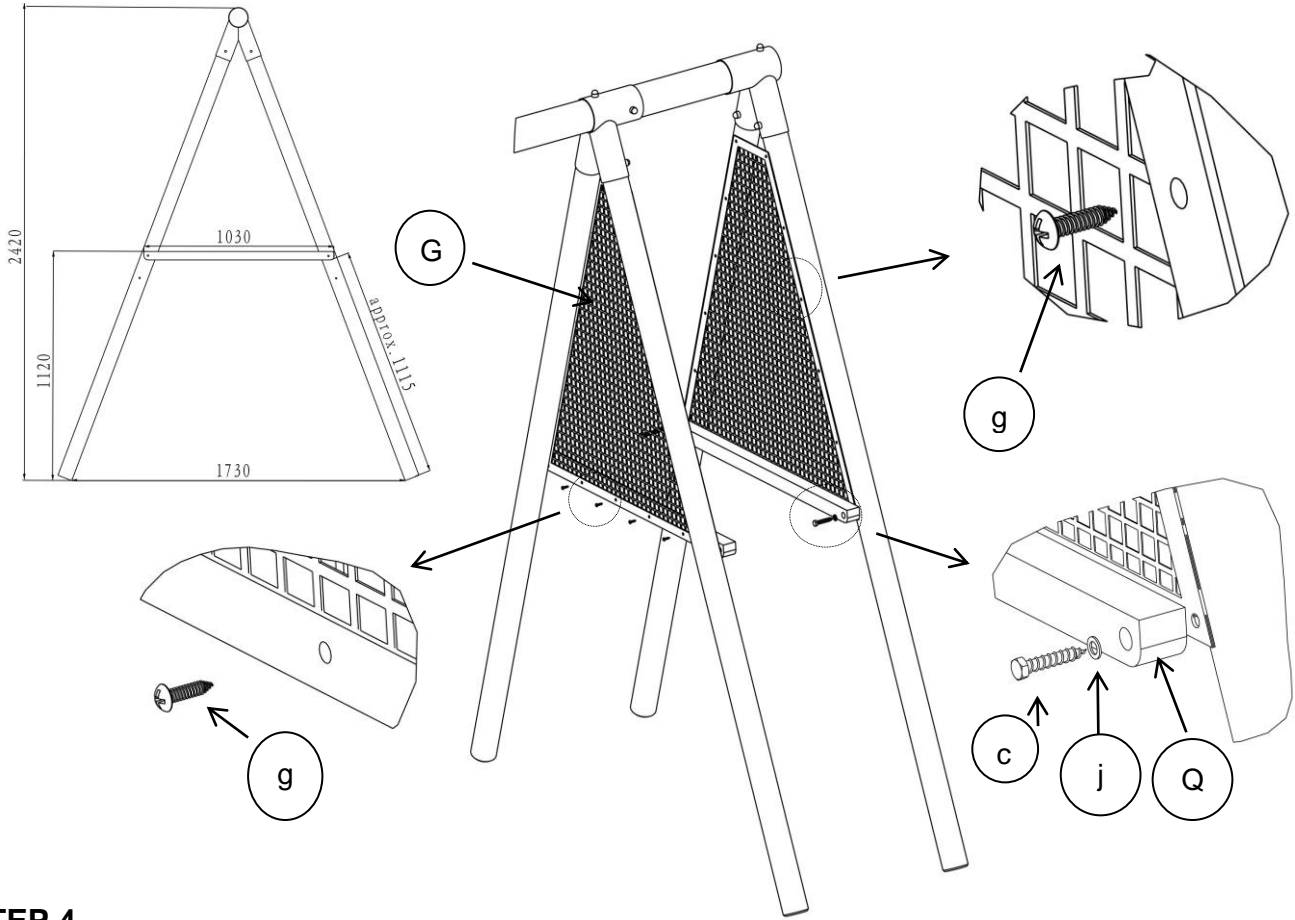

STEP 4

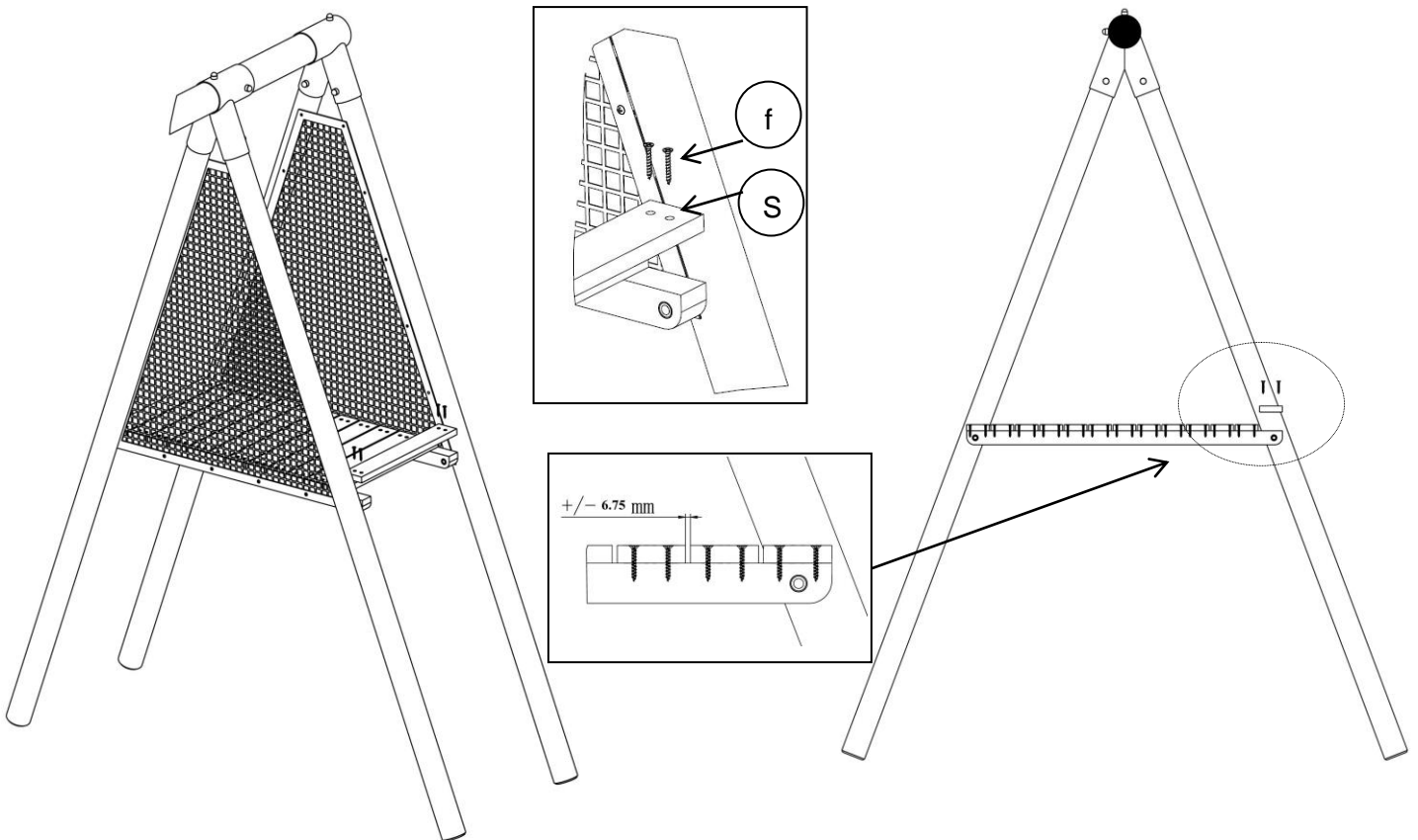

STEP 5

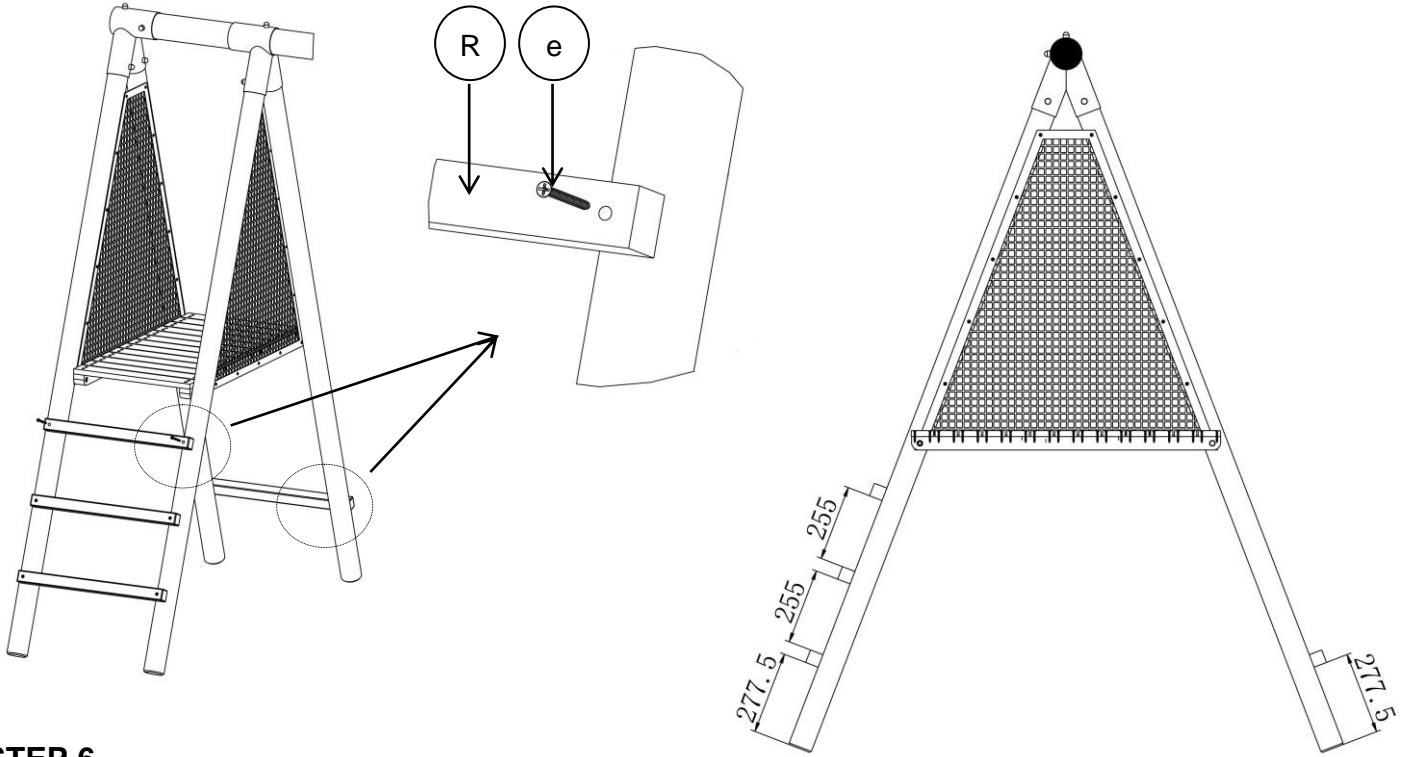

STEP 6

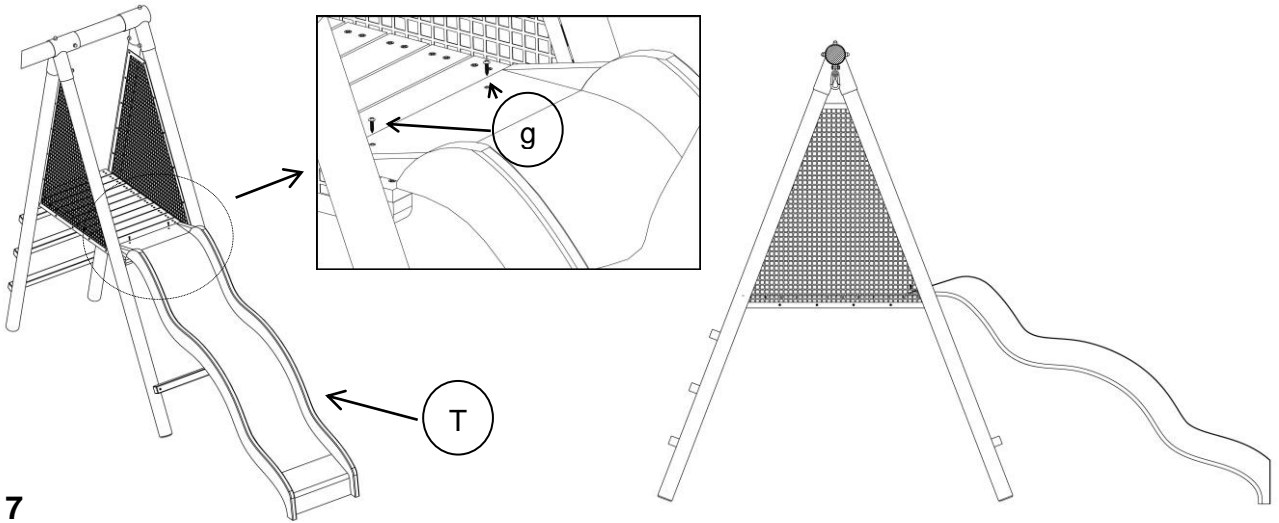

STEP 7

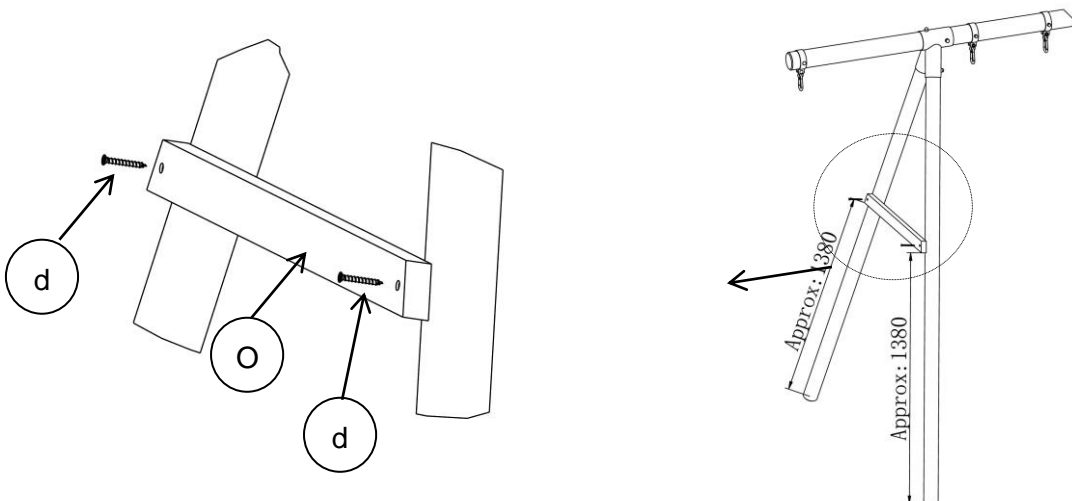

STEP 8 (optional anchoring guide)

Note: the swing can be anchored directly into the ground using the anchors provided.
You may also use cement for additional stability, please follow the below instructions.

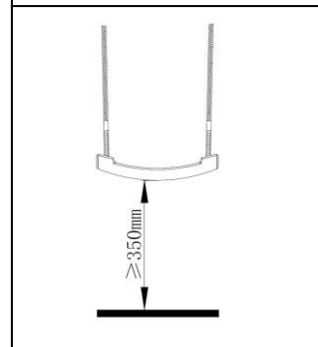
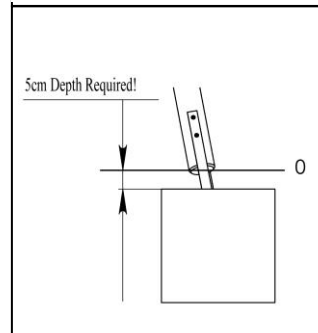
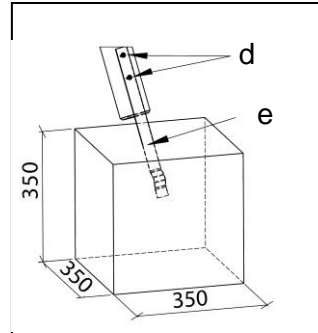
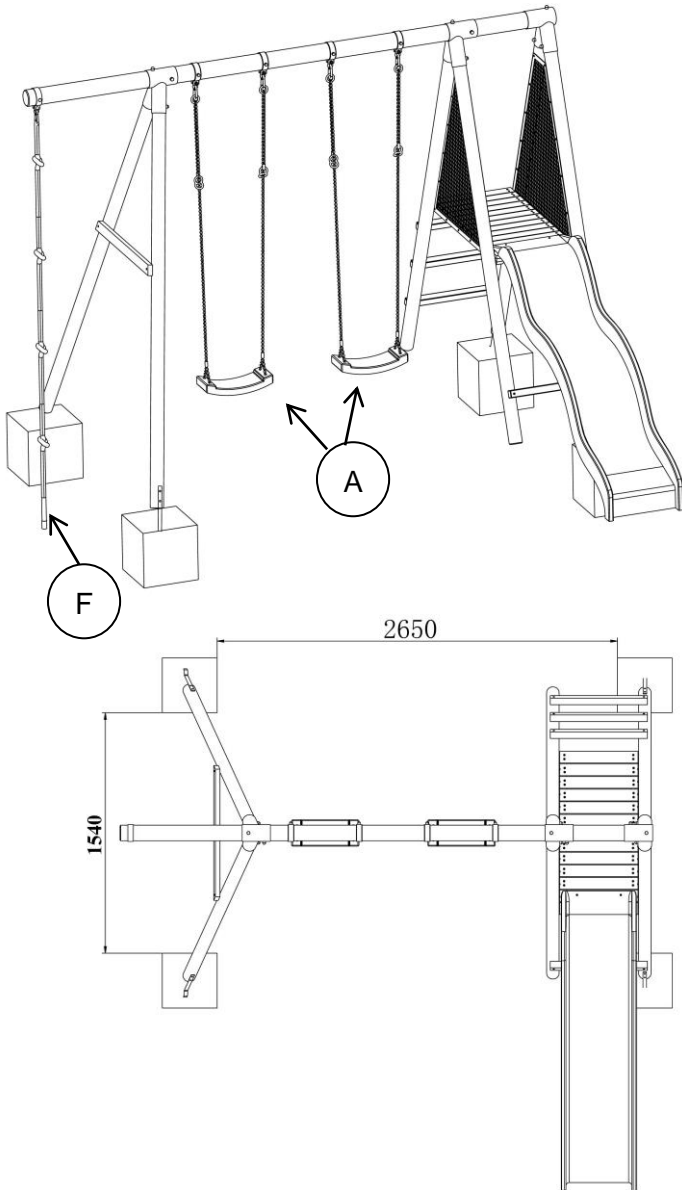

The distance from the ground to the swing element should be $\geq 350\text{mm}$

Safety Perimeter Diagram

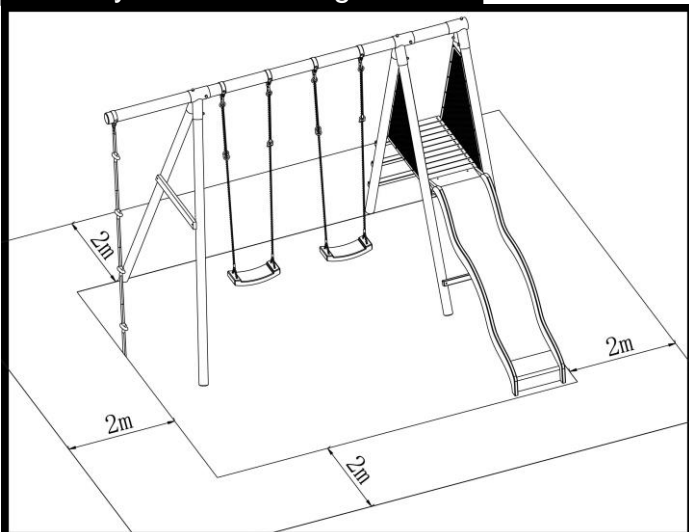

ATTENTION

Recommended Safety Perimeter:

The safe play area refers to the zone extending 2m beyond the equipment on all sides and 700cm above the equipment. The safe area must be free from all structures, landscaping, trees and branches, rocks, wires, sprinkler heads and other similar obstacles which could obstruct safe play. Children can be seriously injured running or colliding into such obstacles.



WARNING

- This product is to be used domestically in an outdoor family environment.
- This equipment may not be used for collective and/or public purposes (playgrounds, camp grounds, schools, nursery schools, etc.)
- This item is designed for children ages 3 to 12 and must be used under adult supervision.

WOOD ADVICE

Our products are manufactured from premium timber. Great care is taken in selecting, machining and treating the timber before it is sold to you.

Bear in mind that timber is a natural product and may experience changes throughout the course of its life. It may:

- Develop openings (gaps, slits, apertures, cracks) along the line of the grain. This occurs due to the moisture content between internal and outer surfaces of the timber. It is totally acceptable and will not affect the integral strength, life or guarantee of the product.
- Fade as the timber reacts with sunlight. The timber should be treated with a proprietary product to act as a protective barrier (i.e. a water repellent, oil or paint on an annual basis)

ASSEMBLY

Assembly must be performed by two adults.

During assembly, the short pieces of wood forming the base of the frame must be embedded 10 or 12 cm (depending on the connectors) before being attached with the coach screws.

ANCHORING

- Anchoring is optional, but is recommended for additional stability
- Anchor kits are provided, cement is not supplied.
- Minimum 5 cm depth below ground level of concrete anchoring is needed.

RECOMMENDATIONS:

- The swing frame must be securely attached.
- For safety reasons, the cement cubes must be poured 5cm below ground level, at the frame's outer angles.
- The swing frame must not be installed directly on cement, asphalt, or any other hard surface.
- Your swing frame must be attached on a flat horizontal surface with a minimum of 2m between it and any structure or obstacle such as a fence, garage house, tree branches, cloths lines, or electric cables.

USING THE EQUIPMENT

Each swing is limited to 50kg max weight and must be used by one child at a time.

For swing frames equipped with a slide, avoid direct sun exposure in order to prevent risks of burns and ensure that the landing area is clear. To slide down the slide, children must be sitting with their feet forward.

During assembly and use, ensure that any splinters are removed.

MAINTENANCE

We recommend regular maintenance should be conducted at the beginning of each season for your play equipment to ensure all main parts/fixings are tightly secured, well-oiled and intact to avoid injury or hazards.

Check the accessories monthly as well as the play equipment's structure in order to prevent falling risks.

Check and retighten screws, bolts and all other hardware elements as necessary, lubricate all moving metallic parts. For longer accessory life, we suggest storing them during the winter. When signs of oxidation and / or rust appear on various metallic parts of your equipment, fix or replace with the appropriate part.

If your play structure is disassembled, be sure to clearly mark the attached metal plates to prevent accidents.

Check all bolt covers and sharp edges and replace them if necessary.

WARRANTY

AUSTRALIAN CONSUMER LAW

Many of our products come with a guarantee or warranty from the manufacturer. In addition, they come with guarantees that cannot be excluded under the Australian Consumer law. You are entitled to a replacement or refund for a major failure and compensation for any other reasonably foreseeable loss or damage.

You are entitled to have the goods repaired or replaced if the goods fail to be of acceptable quality and the failure does not amount to a major failure. Full details of your consumer rights may be found at www.consumerlaw.gov.au

Please visit our website to view our full warranty terms and conditions:

<http://www.lifespankids.com.au/Warranty-Policy-Kids>

Please send all warranty and support inquiries through our ticketing system via the email address:

support@lifespankids.com.au.

