

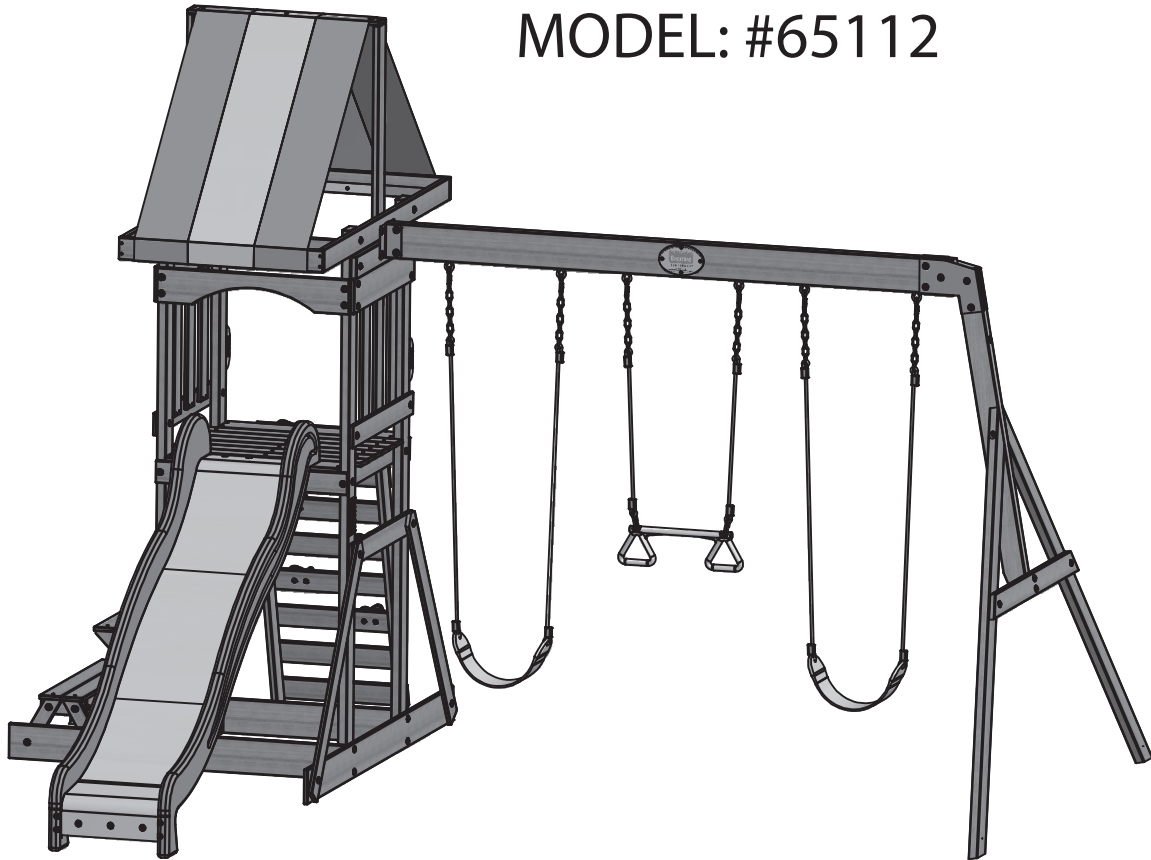

PRESTIGE

WOODEN PLAYSET

MODEL: #65112



- Owner's Manual
- Frequently Asked Questions
- Assembly Instructions
- Warranty Information

Features the **SAFE-T-FUSE** fastening system.
Patent Pending

Save this assembly manual for future reference in the event that you need to order replacement parts.



Free BILT Intelligent Instructions®
Download on <https://biltapp.com/>
Available on Apple and Google Play

Made in China

GENERAL SAFETY INSTRUCTIONS

PURPOSE

This product is intended for outdoor, domestic use only. It is not suitable for commercial or medical use.

DANGER FOR CHILDREN

- **WARNING! No eating while using the product**
- This product may only be used with adult supervision at all times.
- The packaging material is not suitable for children due to choking and suffocation hazards.

RISK OF INJURIES

- Do not use the product if it is damaged or defective. If it is damaged or defective, please contact a qualified technician.
- Check the product before each use. Defective parts must be changed immediately as they can impair the function and the safety of the product.
- No more than one person per swing or per attachment.
- Use the product only on even and non-slipping surfaces. Never use it near water and keep sufficient space around for safety.

PRODUCT DAMAGE

- Do not make alterations to the product. Only use original spare parts. Qualified technicians should only carry out repairs – improper repairs can lead to danger for the user. Use this product only as described in this manual.
- Protect the product against splashes, humidity, high temperature and direct sunlight.

ASSEMBLY ADVICE

- The assembly of the product must be done carefully and by an able-bodied adult. If in any doubt, ask a technically qualified person.
- Before you start with the assembly, read the instructions carefully.
- Remove all packaging materials and lay down all parts on an open space. This gives you an overview and simplifies the assembly procedure.
- Check with the parts list that all parts are available. Dispose of the packaging material when the assembly is completed.
- Beware that when using tools or doing technical work, there is always a risk of injuries. Assemble the product with care.
- Create a danger free environment; for example, do not let tools lay around the workspace. Store the packaging material in a way that cannot cause any danger.
- After installing the product according to the instruction manual, ensure all screws, bolts and nuts are correctly installed and tightened and that all joints are secure.
- Reasonable space must be kept between the product and possible sources of danger, such as other equipment swimming pools and fences.
- The product must be assembled correctly before use.
- Place the product on a level surface at least 2 m from any structure or obstruction such as a fence, garage or house.
- No modifications are to be made to the original product.
- The product must always be used in a well-lit area.
- Do not place anything under the product.
- Use gloves during assembly and disassembly.
- Outdoor products should be equipped with a device that in strong wind conditions avoid displacement due to wind (e.g. steel bars in the ground or loads like sand bag or water bags).

- In certain areas during winter, snow buildup and the low temperatures can damage the product. It is recommended to remove snow buildup and to store the product indoor.
- We strongly recommend visual inspections every 3 months to insure the integrity of the entire product. Replace any parts as necessary.

SAFETY INSTRUCTIONS

- The safety instructions of the product should always be considered and obeyed.
- Using the product may result in permanent injury such as paralysis, or even death. Falling off the product may lead to injuries, particularly to the back, neck or head.
- No clothes with hooks or lose parts should be worn or carried during product usage in order to avoid hooks getting caught and causing injury.
- Moving the product whilst assembled may affect the integrity of the frame. Should it be necessary to move the product, please consider the following:
 - 1.) Force to be evenly spaced around the frame to lift the product off the ground
 - 2.) The product must be carried horizontally
 - 3.) Use caution whilst moving as it could bend the product frame.
- Users should be familiar with the assembly manual. This manual contains assembly guidance; selected precautionary measures as well as recommendations for servicing and maintenance of the product, in order to ensure safe and fun usage.
- It is the responsibility of the owner or the supervisor to guarantee that all users of the product are informed sufficiently of all warning references and safety instructions.

For the supervisor:

The supervisor's role is to make sure users are aware of all safety precautions and that these precautions are enforced. When a supervisor is not available, the product may be disassembled or covered to limit access.

- The product can be only used if it is in good condition, worn or damaged parts should be replaced.
- Objects, which could be dangerous to the user, should be away from the product
- Avoid unauthorized and unsupervised use of the product.
- Do not use the product under influence of alcohol or drugs (incl. medicines).
- Do not use the product or its attachments as a jumping platform.

Consumer Information Sheet for Playground Surfacing Materials

The US Consumer Product Safety Commission (CPSC) estimates that about 100 000 playground equipment-related injuries resulting from falls to the ground surface are treated annually in US hospital emergency rooms. Injuries involving this hazard pattern tend to be among the most serious of all playground injuries, and have the potential to be fatal, particularly when the injury is to the head. The surface under and around playground equipment can be a major factor in determining the injury-causing potential of a fall. It is self-evident that a fall on to a shock-absorbing surface is less likely to cause a serious injury than a fall onto a hard surface. Playground equipment should never be placed on hard surfaces, such as concrete or asphalt, and while grass may appear to be acceptable, it may quickly turn to hard-packed earth in areas of high traffic. Shredded bark mulch, wood chips, fine sand or the gravel are considered to be acceptable shock absorbing surfaces when installed and maintained at a sufficient depth under and around playground equipment.

Table B.1 lists the maximum height from which a child would not be expected to sustain a life-threatening head injury in a fall on to four different loose-fill surfacing materials if they are installed and maintained at depths of 150 mm, 225 mm and 300 mm.

Table B.1: Fall height in millimetres from which a life-threatening head injury would not be expected

Type of Material	Depth of surfacing material		
	150mm	225mm	300mm
Double Shredded Bark Mulch	1800	3000	3300
Wood Chips	1800	2100	3600
Fine Sand	1500	1500	2700
Fine Gravel	1800	2100	3000

However, it should be recognised that all injuries due to falls cannot be prevented, no matter what surfacing material is used.

It is recommended that a shock absorbing material extend a minimum of 1 800 mm in all directions from the perimeter of stationary equipment such as climbing frames and slides. However, because children may deliberately jump from a moving swing, the shock absorbing material should extend in the front and rear of a swing a minimum distance of twice the height of the pivot point measured from a point directly beneath the pivot on the supporting structure.

This information is intended to assist in comparing the relative shock-absorbing properties of various materials. No particular material is recommended over another. However, each material is only effective when properly maintained. Materials should be checked periodically and replenished to maintain correct depth as determined necessary for the equipment in question. The choice of a material depends on the type and height of the playground equipment, the availability of the material in a particular area, and its cost.

WOOD ADVICE

Our products are manufactured from premium timber. Great care is taken in selecting, machining and treating the timber before it is sold to you.

1. Inspect wood parts monthly. The grain of the wood sometimes will lift in dry periods causing splinters to appear. Light sanding may be necessary to maintain a safe environment. Treating your Product with protection (sealant) after sanding will help prevent severe checking/splitting and other weather damage.
2. We have applied a waterborne translucent stain to your unit. This is done for colour only. Once or twice a year, depending on your climate conditions, you must apply some type of protection (sealant) to the wood of your unit. Prior to the application of sealant, lightly sand any "rough" spots on your set. Please note this is a requirement of your warranty.

Bear in mind that timber is a natural product and may experience changes throughout the course of its life.

It may:

- Develop openings/checks (gaps, slits, apertures, cracks) along the line of the grain.
- Fade as the timber reacts with sunlight.

All woods are hygroscopic, that is, it will absorb or discharge moisture to attain equilibrium with the surrounding atmosphere. Timber openings/checks occur due to the moisture content between internal and outer surfaces of the timber. No two pieces of wood are exactly alike. Each piece has its own characteristics and personality and reacts differently to climate changes. When any wood products are exposed to the elements, it develops 'wood checks'. A check is the radial separation of the wood fibres running with the grain of the wood. These are caused by the varying temperature and moisture conditions. A check does not affect the strength or durability of the wood or structural integrity of the play set.

When should wood cracks be a concern?

Most of the wood splits will never become large enough to affect the reliability and strength of our products, however, there can be rare cases where splits can occur. This happens when a crack develops past the halfway point from the timber, splitting it into two separate pieces.

Feel free to contact us with detailed pictures of your product so we can assess and ensure that your playground remains safe.

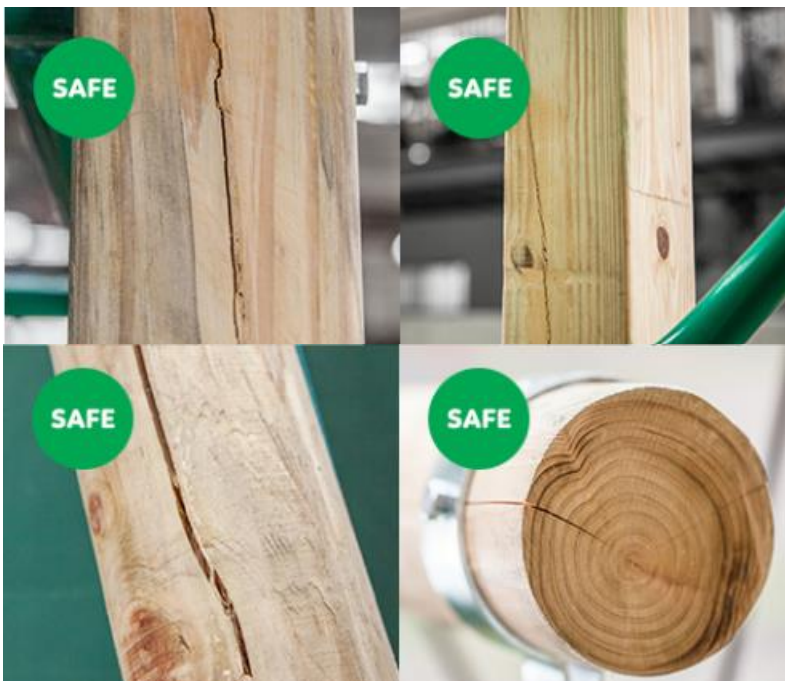

Dimensional timbers contain very little heart wood so less splits can be seen.

Round pole swing sets are very thick so that cracks (shown left) will not affect the strength and durability of our swing sets.

RECOMMENDATIONS:

- The swing frame must be securely attached.
- For safety reasons, the cement cubes must be poured 5cm below ground level, at the frame's outer angles.

- The swing frame must not be installed directly on cement, asphalt, or any other hard surface.
- Your swing frame must be attached on a flat horizontal surface with a minimum of 2m between it and any structure or obstacle such as a fence, garage house, tree branches, cloths lines, or electric cables.

For more information: <http://www.lifespankids.com.au/natural-timber>

Play Set Assembly Manual FAQs:

1. Does the area for the playset need to be level?

Yes. We recommend the playset be positioned on a flat level area for maximum safety and durability. The stakes provided should be used to secure it firmly to the ground.

2. What age range is appropriate for the playsets?

The playsets are recommended for children ages 3 – 10 years.

3. Is the wood treated with chemicals?

We use 100% Chinese Cedar wood which is naturally bug resistant, decay and rot resistant. To help ensure your child's safety, our wood is completely chemical free and we do not use pressure-treated wood. The stain we use is a top coat using a water-based product that is for appearance only.

4. How often should the playset be stained?

We recommend the playset be stained once each year. A water or oil based stain can be used at the customer's discretion.

5. Why does it seem that my swing set is developing cracks?

Wood is a natural material; no two pieces are exactly alike. Each piece has its own characteristics and personality and reacts differently to climate changes. When any wood product is exposed to the elements, it develops "wood checks". A check is the radial separation of the wood fibers running with the grain of the wood. These are caused by the varying temperature and moisture conditions. A check is not a crack – it does not affect the strength or durability of the wood or structural integrity of the play set.

6. Do the playsets come with a warranty?

Yes. All Lifespan Kids products carry replacement warranty on all parts for manufacturer's defect. Please see warranty details for more information.

7. What is the best way to get started assembling the playset?

We recommend taking all the parts out of the boxes and arranging them by part number before you begin any assembly. This will not only allow faster assembly, but will also identify any parts that may be missing or damaged so they can be replaced before assembly.

8. The playset seems to rock or sway too much. What's wrong?

Rocking is caused by uneven ground or obstructions such as rocks, roots, etc. under the ground rails. These should be removed and the ground underneath re-leveled to prevent rocking. Also ensure the playset is securely staked to the ground using the anchors provided.

9. The 2"x4" boards do not measure 2"x 4". Why not?

In it is common practice to describe lumber dimensions using the rough cut sizes from the sawmill and not the finished dimensions. Retailers, home stores, etc. all use this accepted practice for describing lumber dimensions. However, the playset is designed and constructed using the actual dimensions so everything fits properly and remains so during the life of the playset.

10. The end beam is not straight up and down. Why not?

This is normal. Backyard Discovery designs playsets this way to ensure the strongest structure possible. The slight angle adds strength and reduces rocking and twisting.

11. The S-hooks for the swings won't close. What is wrong?

We recommend placing them on a hard surface such as concrete (don't do this on anything that will dent such as metal or finished wood or glass which will break!). It will take quite a few strokes, but the hooks will close.

Tools Required for Installation:

(These are the tools that are generally required for assembly of our outdoor products. These tools are not included with the outdoor product purchase.)

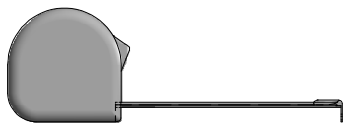

(Tape Measure)



(Claw Hammer)

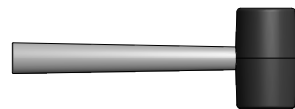

(Rubber Mallet - Optional)

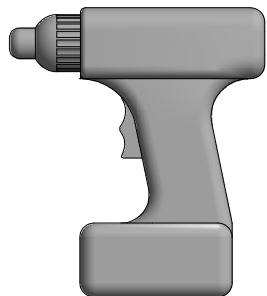

(Cordless Drill or Electric Drill)



(1/8" & 3/8" Drill Bits)



***(Drill Attachments:
Phillips Head)***



(An Adult w/ an Adult Helper)

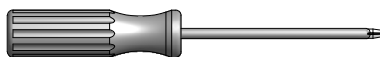

(Phillips Screw Driver)



(Ladder)

Basic Setup Dimensions

Place the set on level ground, not less than 6 ft [2 m] from any structure or obstruction such as a fence, garage, house, overhanging branches, laundry lines, or electrical wires.

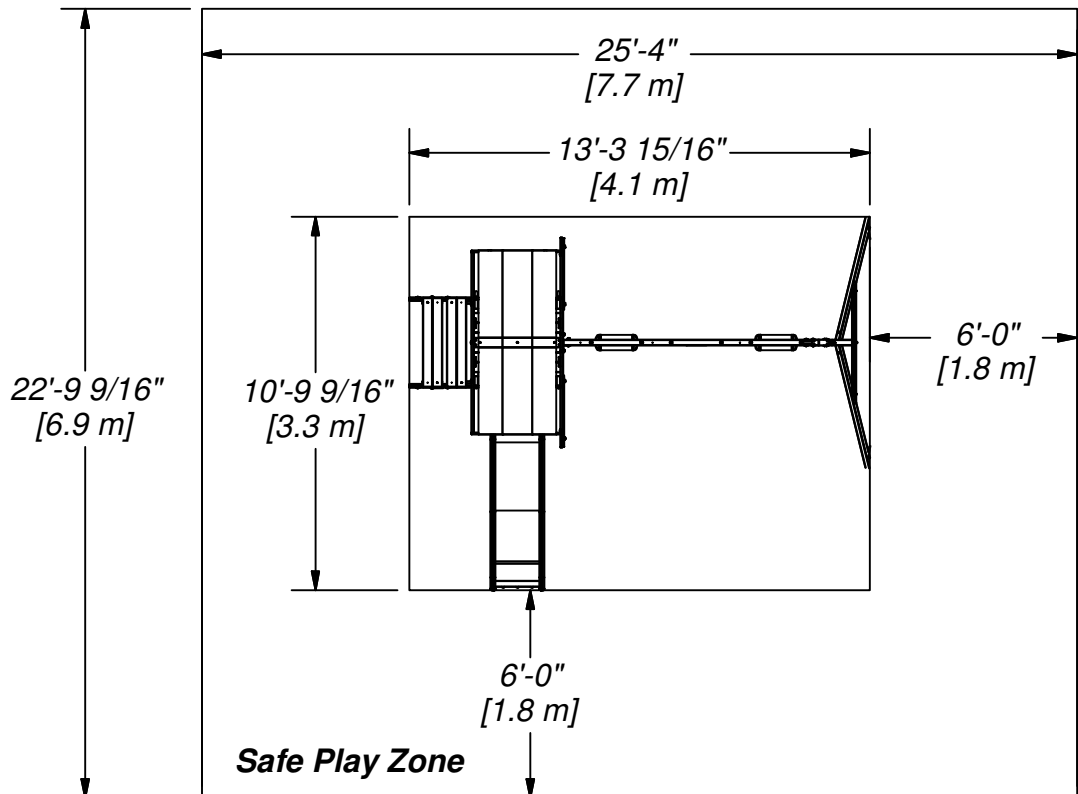

General Information:

Your set has been designed and engineered for children only and for residential use only.
A maximum of 150 lbs. per child is recommended for play activities designed for individual use.
A maximum of 120 lbs. per child is recommended for play activities designed for multiple child use.
A maximum of 9 children is recommended for this swing set.

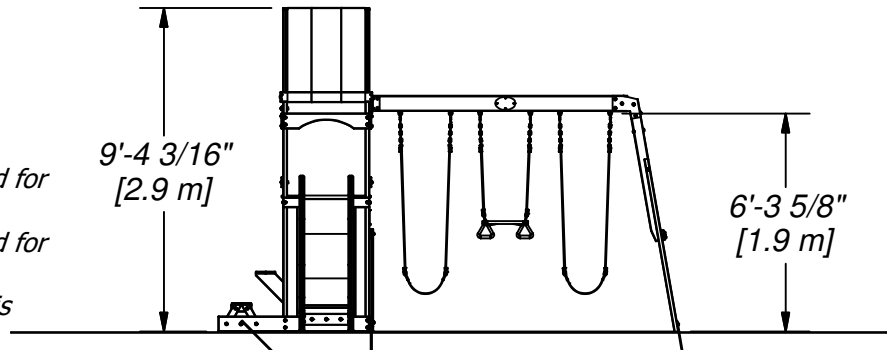

Important Assembly Notes

Safe play height: 15'-4 3/16" [4.7 m]
Maximum fall height: 6'-3 5/8" [1.9 m]

- 1) While assembling unit, take time before and after each phase to make sure fort is level. If fort is not level, assembly will be difficult and improper assembly may result. Extra care must be taken to ensure the fort is square.
- 2) Tighten bolts securely, tighten nuts on bolts flush to the tube or member.
- 3) Pay close attention to the ITEMS NEEDED FOR EACH PHASE. They can be a valuable aid when sorting your wood and hardware. Assembly will be made easier if items are sorted by phase.
- 4) Pay close attention to make sure you are using the correct hardware in the correct phases. Using incorrect hardware may result in improper assembly.
- 5) Whenever a T-nut is used, follow these directions. Place T-nut in pre-drilled hole. Tap in with hammer. Place bolt with washers in the opposite side. Hand tighten to make sure the bolt is in the T-nut. DO NOT over tighten.
- 6) Read the steps of each phase thoroughly. The written steps may include important information not shown in the illustrations.

Parts Identification

Wood Components

(NOT TO SCALE)



- (1) **E1 - FORT UPRIGHT - W4L05999**
1 3/8"x3 3/8"x83" (36x86x2108)



- (1) **E2 - FORT UPRIGHT - W2A01698**
1 3/8"x3 3/8"x83" (36x86x2108)



- (1) **E3 - FORT UPRIGHT - W4L05994**
1 3/8"x3 3/8"x83" (36x86x2108)

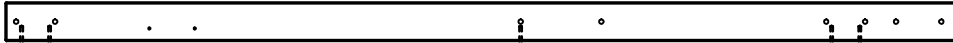

- (1) **E4 - FORT UPRIGHT - W4L06000**
1 3/8"x3 3/8"x83" (36x86x2108)

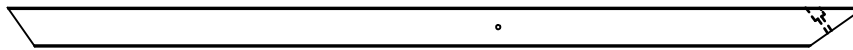

- (2) **E77 - ANGLE BRACE - W4L04854**
1 3/8"x3 3/8"x74 3/8" (36x86x1890)

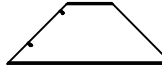

- (2) **G1 - PICNIC TOP SUPPORT - W4L05998**
1"x5 1/4"x13 7/8" (24x134x352)



- (1) **H1 - ROOF CROSS BRACE - W102301**
1"x3 3/8"x62 1/2" (24x86x1588)



- (2) **H2 - ROCKWALL SUPPORT - W102334**
1"x3 3/8"x48 7/8" (24x86x1242)



- (2) **H3 - TARP UPRIGHT - W102340**
1"x3 3/8"x37" (24x86x940)



- (2) **H4 - FLOOR JOIST - W102308**
1"x3 3/8"x30" (24x86x762)

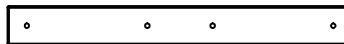

- (1) **H5 - SWINGBEAM RAIL - W102303**
1"x3 3/8"x30" (24x86x762)



- (1) **H6 - FLOOR SUPPORT - W102338**
1"x3 3/8"x30" (24x86x762)

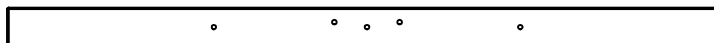

- (1) **H7 - ROOF CROSS BRACE - W4L05909**
1"x3 3/8"x62 1/2" (24x86x1588)

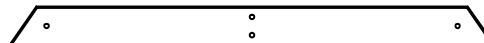

- (1) **H79 - END SUPPORT - W4L04855**
1"x3 1/2"x42" (24x86x1072)



- (2) **J1 - TIE STRAP - W4L05996**
1"x2 3/8"x7" (24x60x178)

Parts Identification

Wood Components

(NOT TO SCALE)



- (1) **K1 - GROUND BOARD - W4L06005**
5/8"x5 1/4"x72 3/4" (16x134x1848)



- (2) **K2 - GROUND BOARD - W4L05997**
5/8"x5 1/4"x52 1/2" (16x134x1334)



- (3) **K3 - WALL RAIL - W102302**
5/8"x5 1/4"x30" (16x134x762)



- (2) **K4 - ARCHED WALL RAIL - W102306**
5/8"x5 1/4"x30" (16x134x762)



- (2) **K5 - OUTER FLOOR BOARD - W102333**
5/8"x5 1/4"x27 1/8" (16x134x688)



- (2) **M1 - ANGLE BRACE - W4L06001**
5/8"x3 3/8"x41 1/2" (16x86x1053)



- (2) **M2 - TARP SUPPORT - W102337**
5/8"x3 3/8"x31 7/8" (16x86x810)



- (4) **M3 - PICNIC SEAT/TOP - W102347**
5/8"x3 3/8"x31" (16x86x786)



- (6) **M4 - FLOOR BOARD - W102332**
5/8"x3 3/8"x30 7/8" (16x86x785)



- (1) **M5 - FLOOR SUPPORT - W102309**
5/8"x3 3/8"x30" (16x86x762)



- (2) **M6 - FLOOR SUPPORT - W102331**
5/8"x3 3/8"x30" (16x86x762)



- (1) **M7 - FLOOR SUPPORT - W4L06003**
5/8"x3 3/8"x30" (16x86x762)



- (1) **M8 - TARP SUPPORT - W102341**
5/8"x3 3/8"x30" (16x86x762)



- (1) **M9 - SAFETY BOARD - W4L06006**
5/8"x3 3/8"x30" (16x86x762)



- (2) **M10 - ROCKWALL BOARD - W102335**
5/8"x3 3/8"x20 1/4" (16x86x514)

Parts Identification

Wood Components

(NOT TO SCALE)

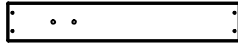

- (6) **M11 - ROCKWALL BOARD - W4L06002**
5/8"x3 3/8"x20 1/4" (16x86x514)

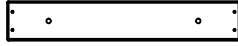

- (1) **M12 - ROCKWALL BOARD - W4L06004**
5/8"x3 3/8"x20 1/4" (16x86x514)

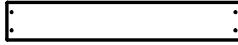

- (6) **M49 - PICKET - 53 - W4L05374**
5/8"x3 3/8"x20 3/8" (16x86x518)

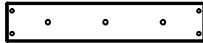

- (1) **M77 - SLIDE BRACE - W100544**
5/8"x3 3/8"x17 1/4" (16x86x438)



- (2) **M78 - CENTER SLIDE BRACE - W100545**
5/8"x3 3/8"x17 1/4" (16x86x438)

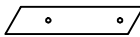

- (4) **N2 - PICNIC TABLE BRACE - W4L05995**
5/8"x2 3/8"x12" (16x60x305)



- (2) **N3 - TIE STRAP - W102344**
5/8"x2 3/8"x6" (16x60x152)



- (1) **O1 - SAFETY BOARD - W102307**
5/8"x1 3/8"x30" (16x34x762)



- (1) **SB74 - SWING BEAM EXTENDED - W102419**
2"x5 1/4"x89 1/2" (50x134x2274)

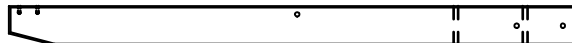

- (1) **W71 - SWING BEAM SUPPORT - W4L04856**
2"x3 3/8"x49 5/8" (50x86x1260)

Parts Identification

Hardware

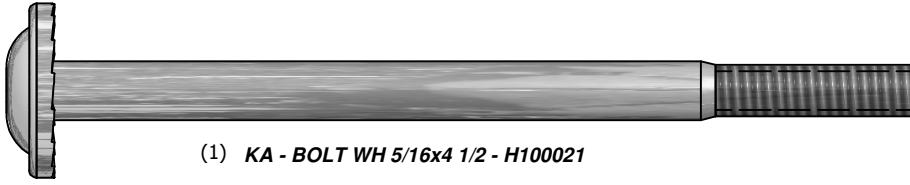

(1) KA - BOLT WH 5/16x4 1/2 - H100021

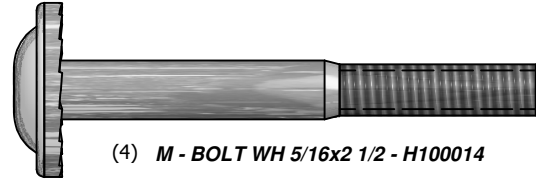

(4) M - BOLT WH 5/16x2 1/2 - H100014

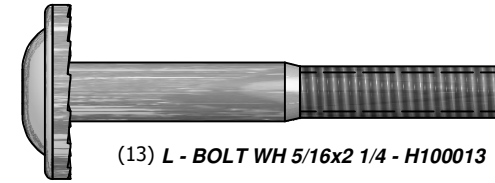

(13) L - BOLT WH 5/16x2 1/4 - H100013

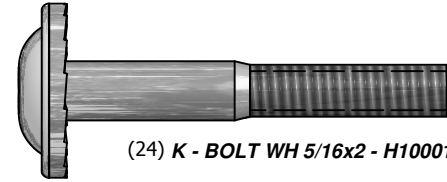

(24) K - BOLT WH 5/16x2 - H100012

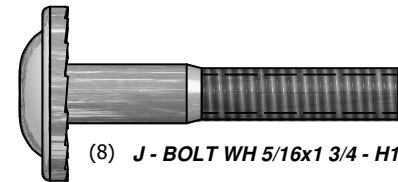

(8) J - BOLT WH 5/16x1 3/4 - H100011

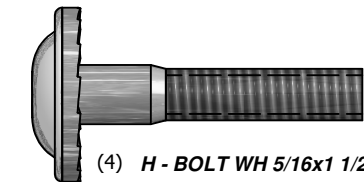

(4) H - BOLT WH 5/16x1 1/2 - H100010

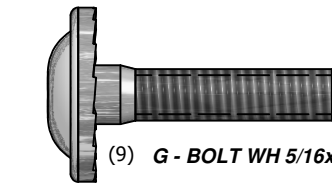

(9) G - BOLT WH 5/16x1 1/4 - H100009

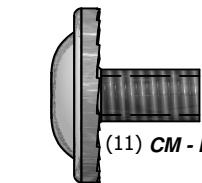

(11) CM - BOLT WH 5/16x1/2 - H100115



(13) BE - T-NUT 1/4 - H100072

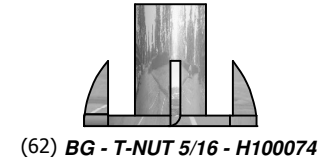

(62) BG - T-NUT 5/16 - H100074

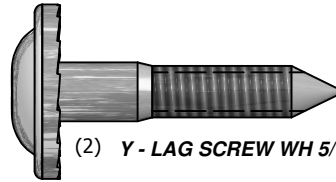

(2) Y - LAG SCREW WH 5/16x1 1/2 - H100026

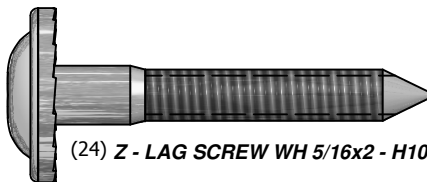

(24) Z - LAG SCREW WH 5/16x2 - H100027

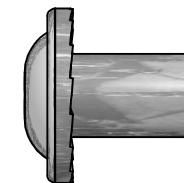

(4) B - NUT BARREL WH 5/16x5/8 - H100004



(7) D - NUT BARREL WH 5/16x7/8 - H100005

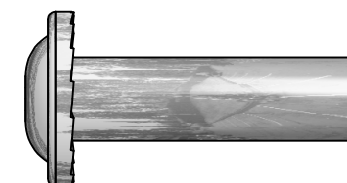

(2) C - NUT BARREL WH 5/16x1 1/2 - H100006

Parts Identification

Hardware

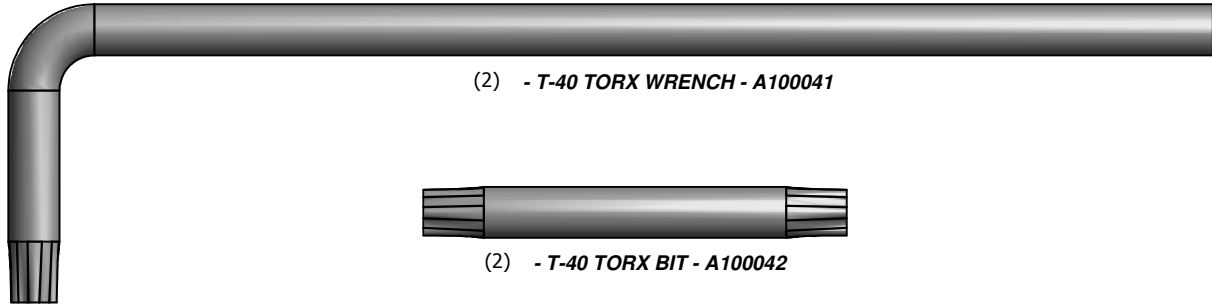

(2) - T-40 TORX WRENCH - A100041



(2) - T-40 TORX BIT - A100042



(2) AN - BOLT HEX 5/16x2-3/4 - H100047

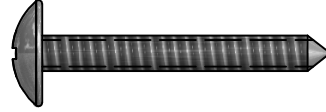

(4) CH - SCREW TAPPING 14x1-1/2 - H100109



(4) AJ - BOLT HEX 5/16x1 1/4 - H100042



(4) BW - SCREW PFH 8x3 - H100092



(26) BT - SCREW PFH 8x2 1/2 - H100090



(17) BV - SCREW PFH 8x2 1/4 - H100091



(80) BP - SCREW PFH 8x1 1/2 - H100086



(35) BR - SCREW PFH 8x1 1/8 - H100088



(16) CY - SCREW PWH 8x5/8 - H100128

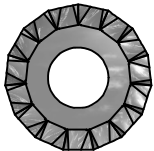

(79) AC - WASHER LOCK EXT 8x19 - H100030

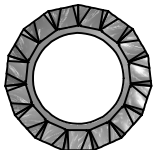

(8) AD - WASHER LOCK EXT 12x19 - H100031

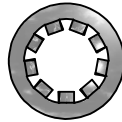

(17) CG - WASHER LOCK INT 8x15 - H100108

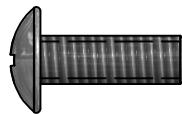

(13) BA - BOLT PTH 1/4x3/4 - H100063

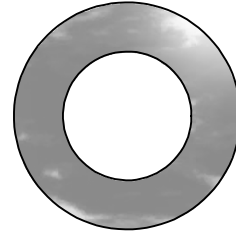

(7) CB - WASHER SAFETY 17x30 - H100103

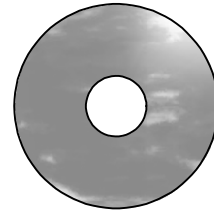

(15) CD - WASHER FLAT 8x27 - H100105

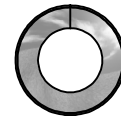

(4) BX - WASHER SPLIT 5/16 - H100095



(4) CE - WASHER FLAT 9x18 - H100106

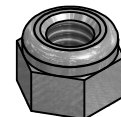

(9) CJ - NUT LOCK 5/16 - H100110

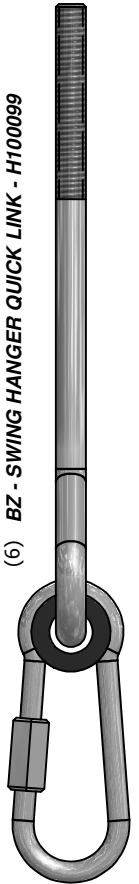

(6) BZ - SWING HANGER QUICK LINK - H100099

Parts Identification

Accessories (NOT TO SCALE)

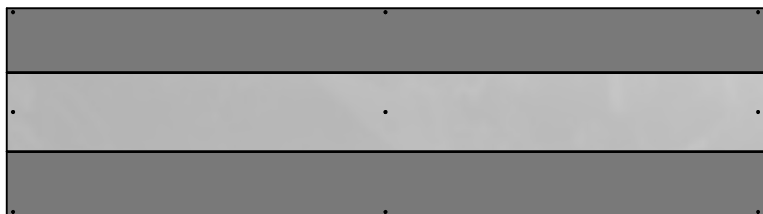

(1) **UA - TARP .4x686x2506 - A100341**
1/64"x27"x98 5/8" (.4x686x2506)

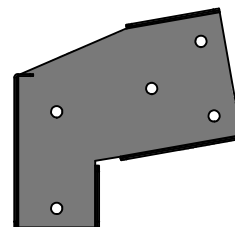

(1) **TB - SWING BEAM EXTENSION BRACKET-LEFT - A100325**

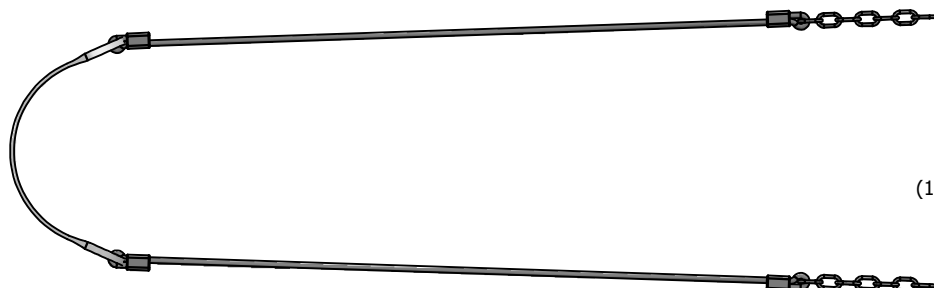

(2) **SWING WITH ROPE-CHAIN (GY) 53.25" - A100121**

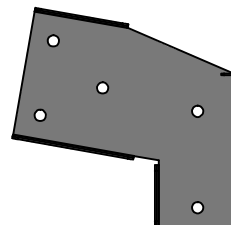

(1) **TC - SWING BEAM EXTENSION BRACKET-RIGHT - A100326**



(2) **EA - HAND GRIP YELLOW PLASTIC - A100043**

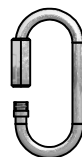

(2) **FA - QUICK LINK - A100069**

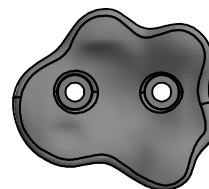

(3) **- GREEN HC ROCK #1 - A6P00036**



(1) **HC - BYD ID TAG (LARGE) 2011 WITH AGES - A100164**

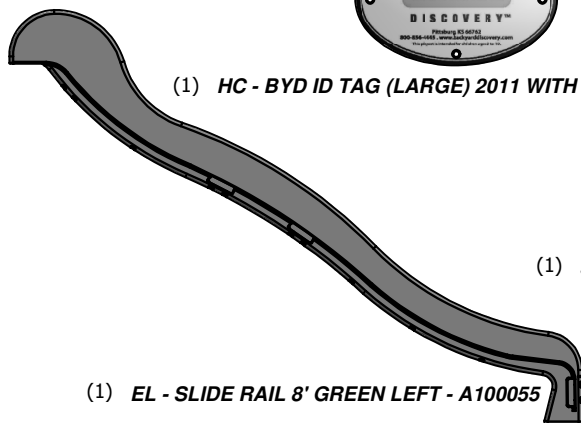

(1) **EL - SLIDE RAIL 8' GREEN LEFT - A100055**

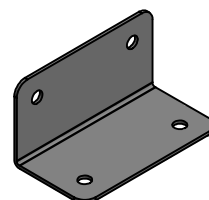

(2) **GD - L BRACKET 66x66x127 - A100140**



(1) **SR - "B" REVISION TAG - A100315**

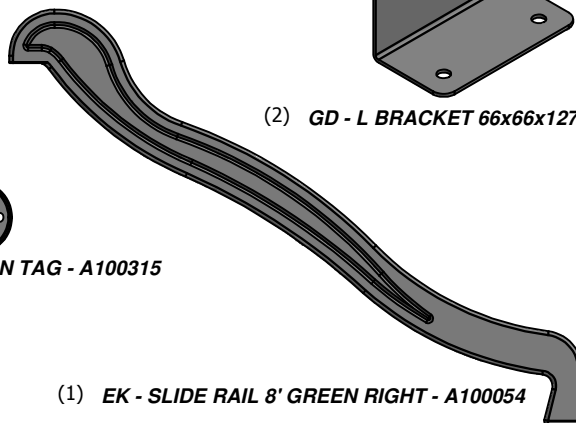

(1) **EK - SLIDE RAIL 8' GREEN RIGHT - A100054**



(1) **EM - SLIDE BED 8' YELLOW - A100056**



(1) **- TRAPEZE - A6P00034**

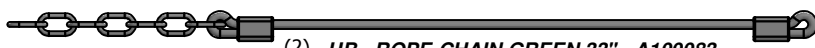

(2) **UB - ROPE-CHAIN GREEN 33" - A100083**



(6) **- GROUND STAKE REBAR - A4M00527**



(3) **- GREEN HC ROCK #2 - A6P00037**

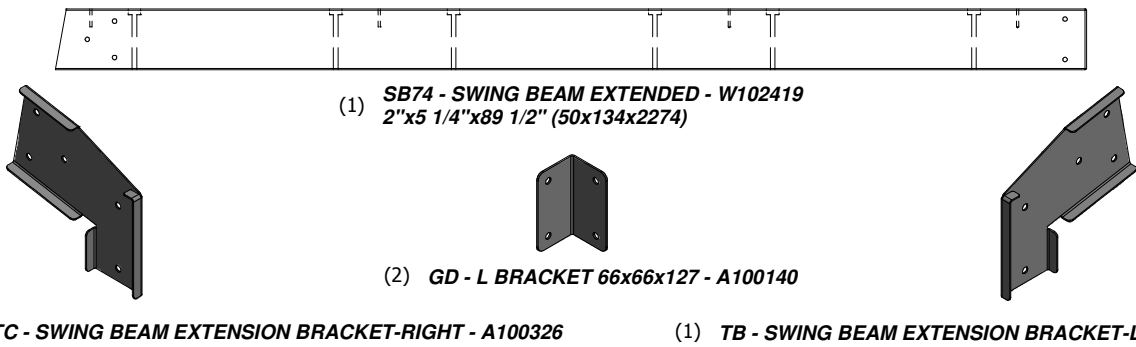

**SWING BEAM ASSEMBLY
STEP 1**

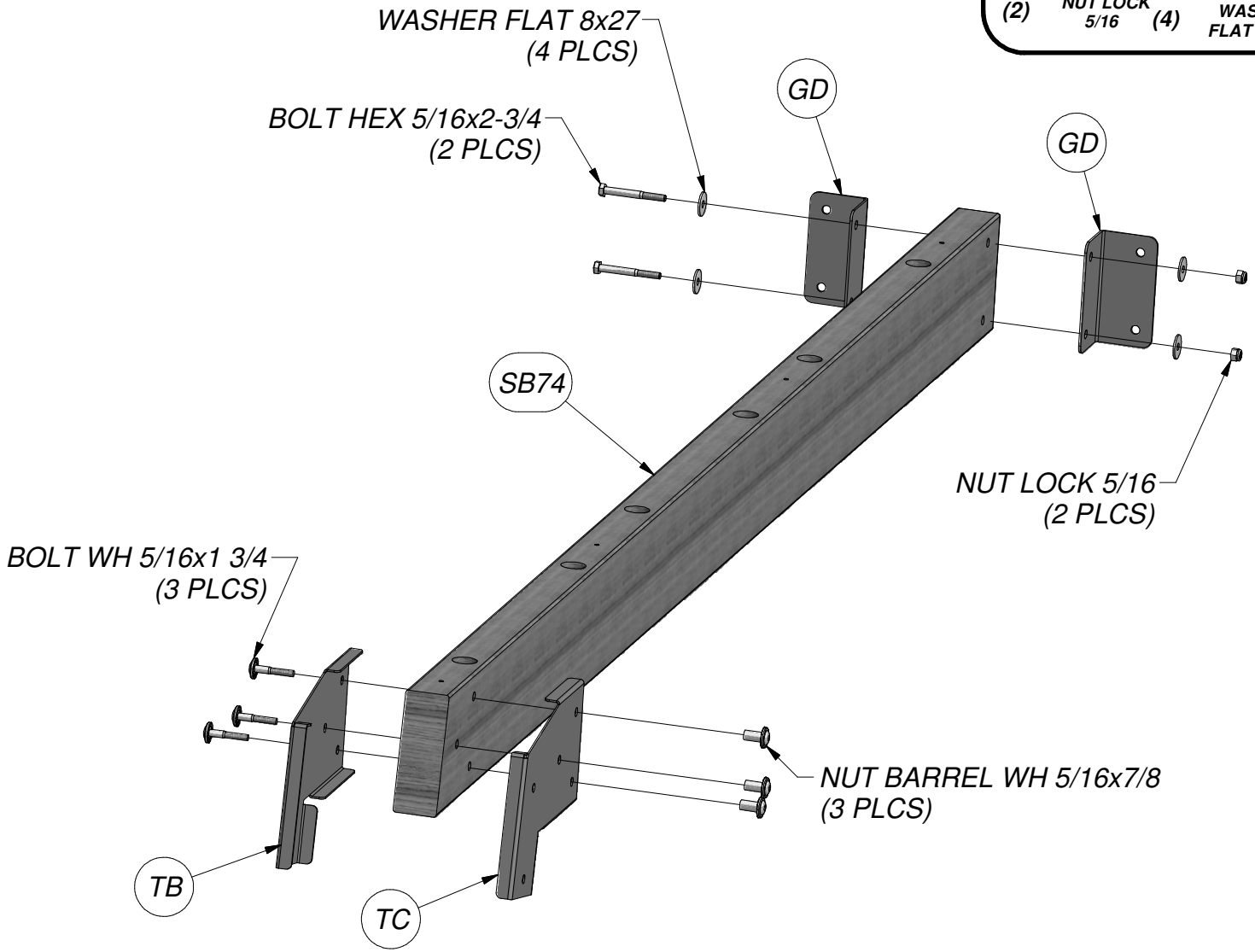
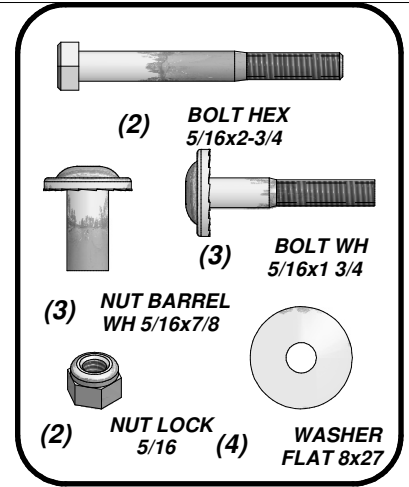

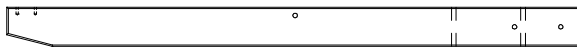

(1) **W71 - SWING BEAM SUPPORT - W4L04856**
2"x3 3/8"x49 5/8" (50x86x1260)

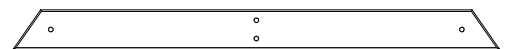

(1) **H79 - END SUPPORT - W4L04855**
1"x3 1/2"x42" (24x86x1072)



(2) **E77 - ANGLE BRACE - W4L04854**
1 3/8"x3 3/8"x74 3/8" (36x86x1890)

SWING BEAM ASSEMBLY STEP 2

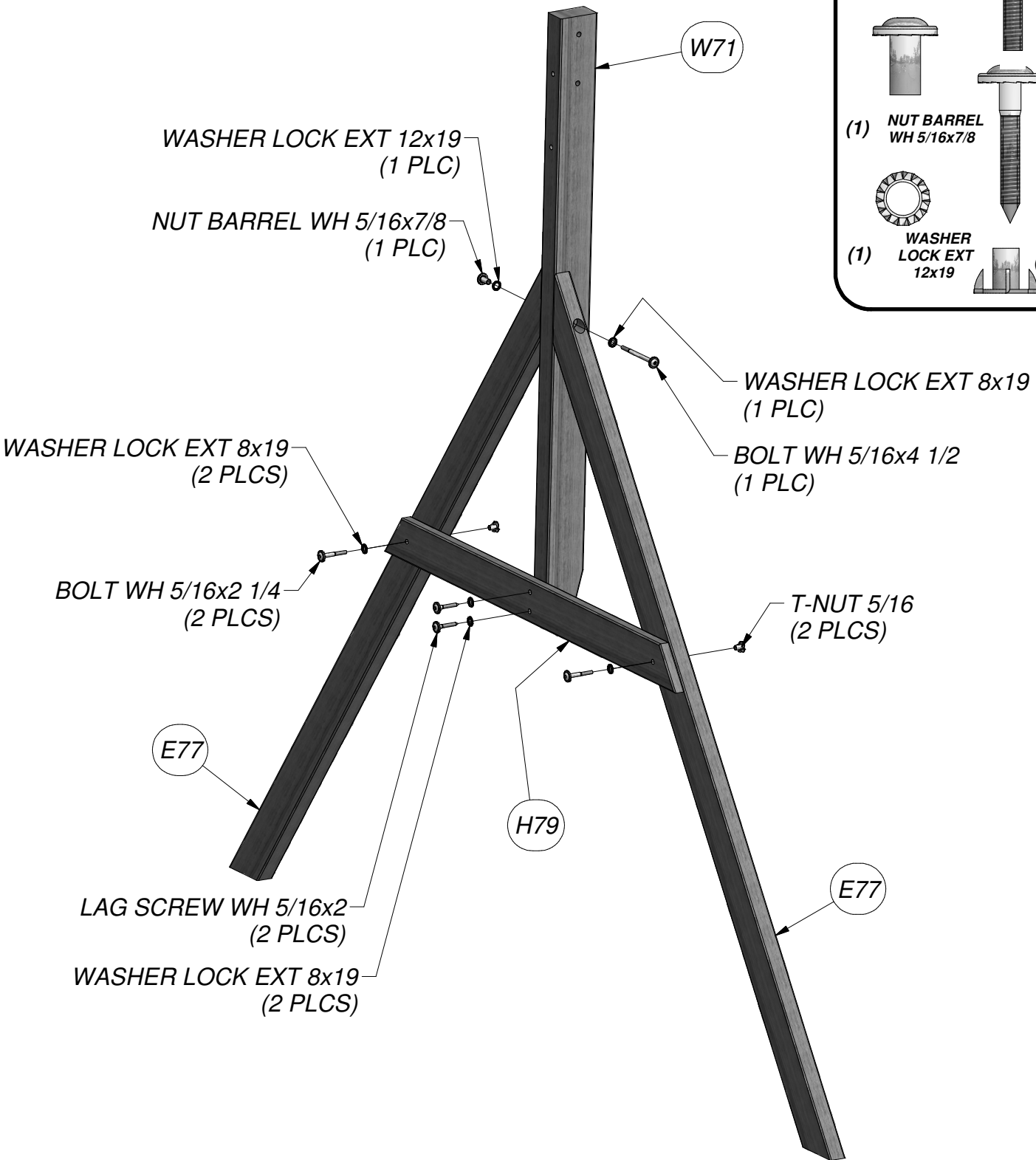
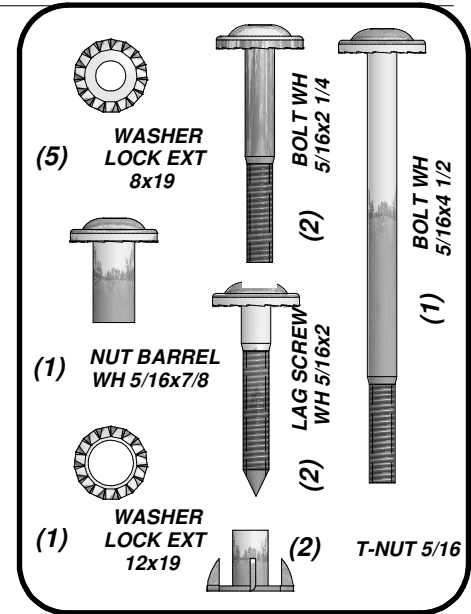

**SWING BEAM ASSEMBLY
STEP 3**

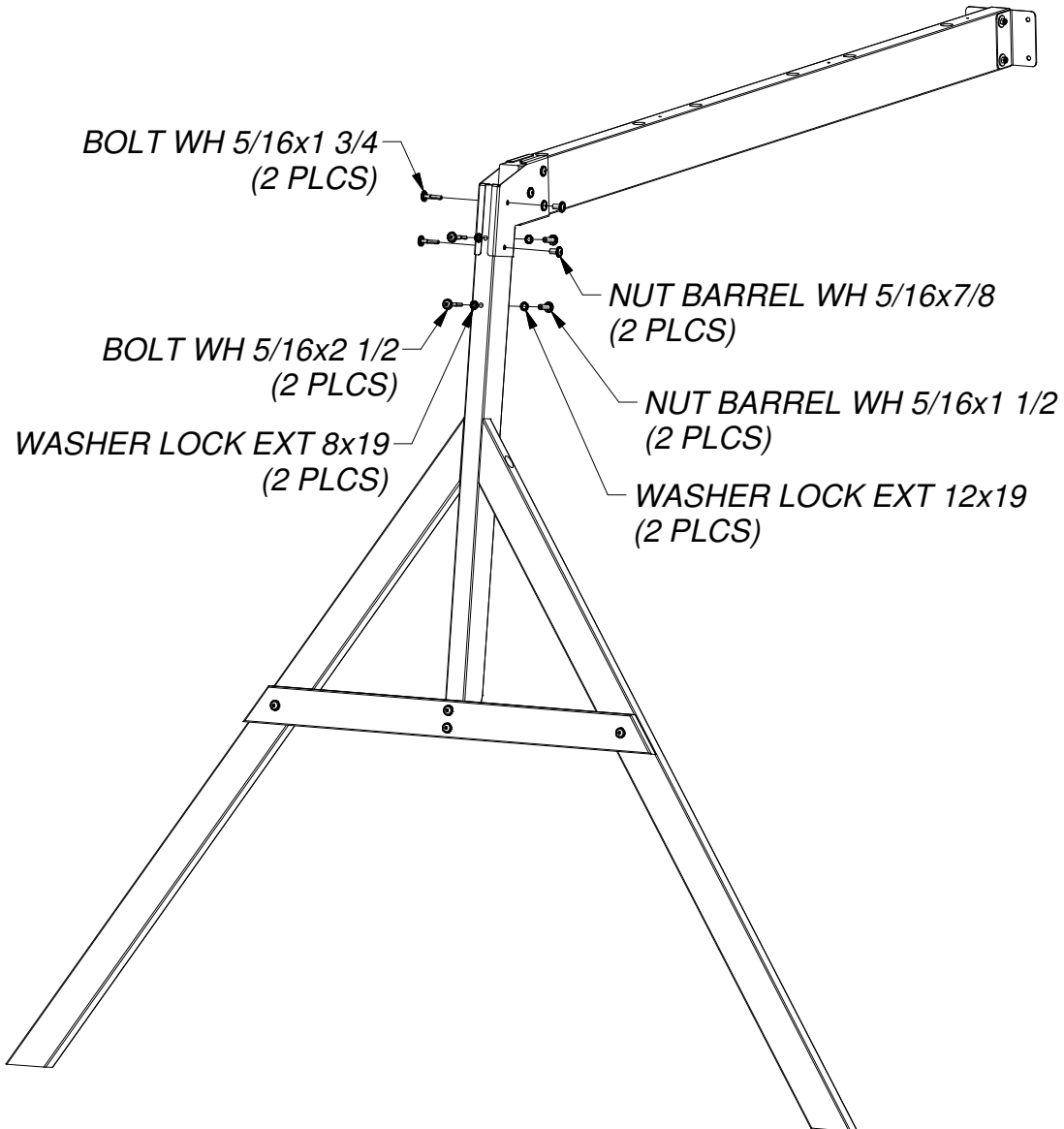
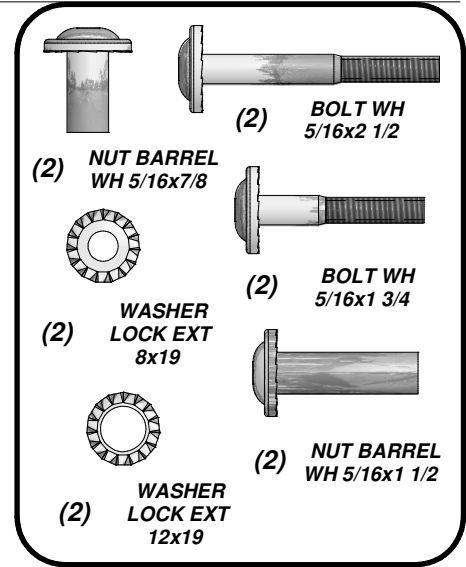



(6) **BZ - SWING HANGER QUICK LINK - H100099**

SWING BEAM ASSEMBLY STEP 4

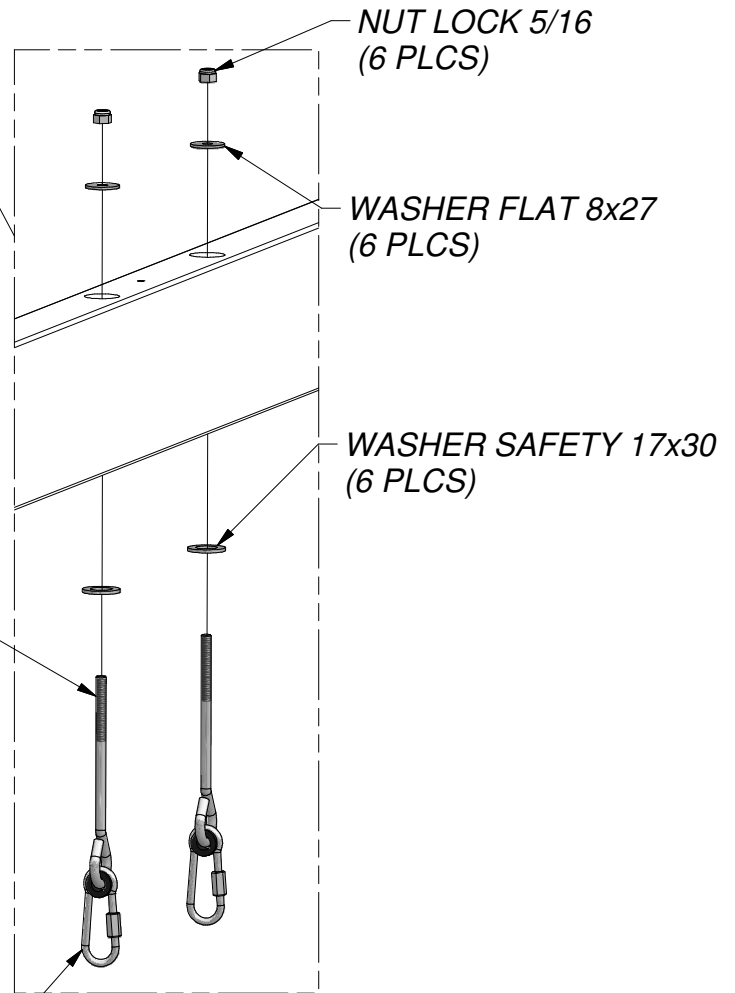
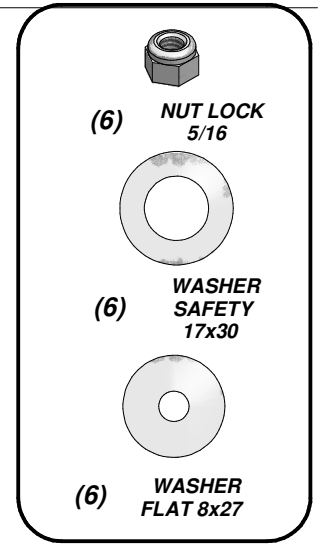
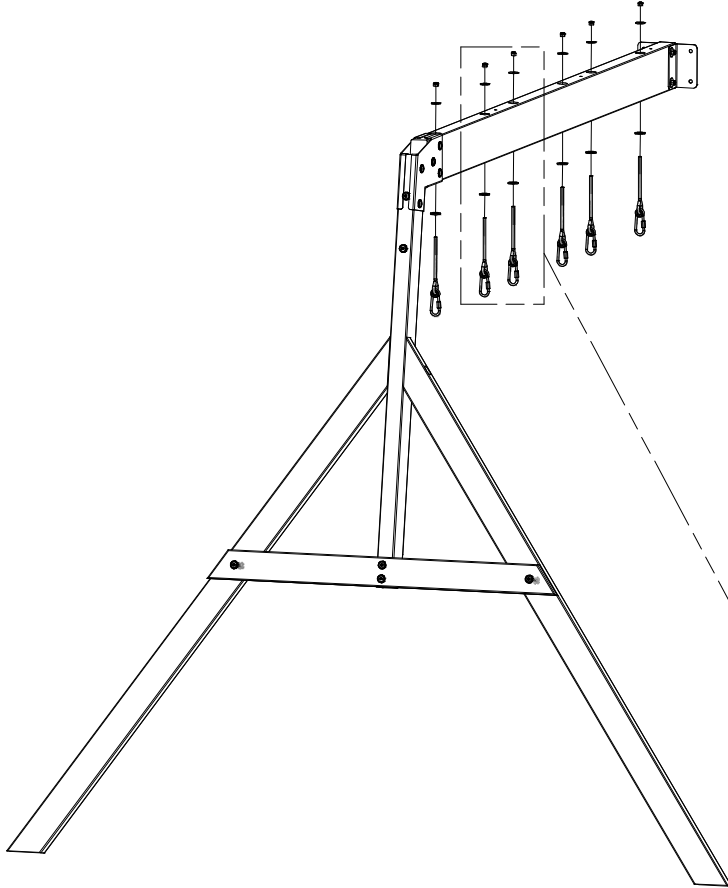

1. Lock nut must be tightened until loop is tight against the safety washer.
2. Swing hanger bolt must be oriented as shown to avoid damage to swing hanger bolt.

SWING HANGER QUICK LINK (6 PLCS)

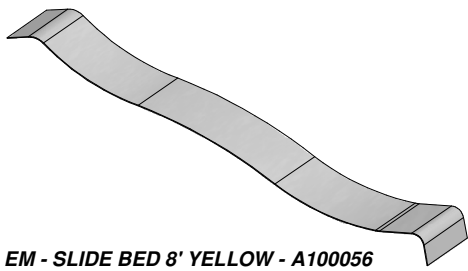

(1) EM - SLIDE BED 8' YELLOW - A100056

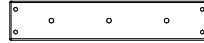

(1) M77 - SLIDE BRACE - W100544
5/8"x3 3/8"x17 1/4" (16x86x438)

SLIDE ASSEMBLY STEP 1

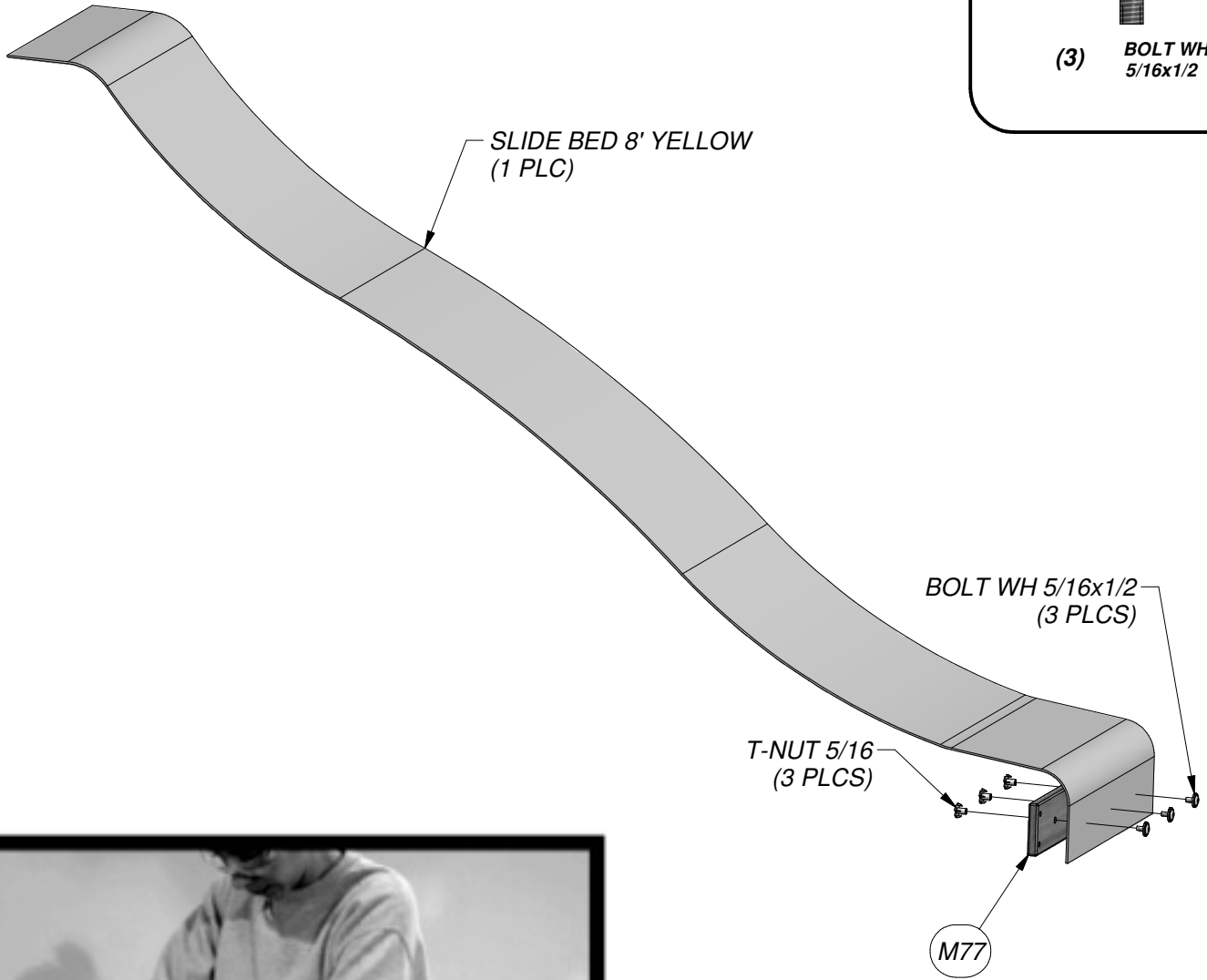
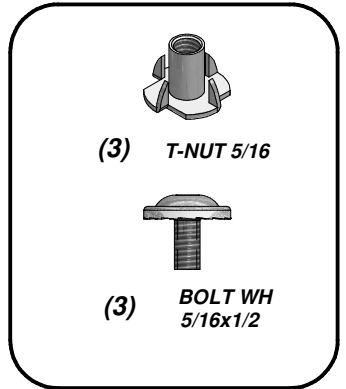

USE 'M77' SLIDE BRACE AS A TEMPLATE FOR DRILLING BOTTOM HOLE PATTERN IN SLIDE BED. BE SURE TO PLACE SLIDE BRACE UP 1/4" FROM BOTTOM EDGE OF SLIDE BED BEFORE MARKING HOLE PATTERN.

TIP: PREBENDING THE ENDS WILL EASE ASSEMBLY.

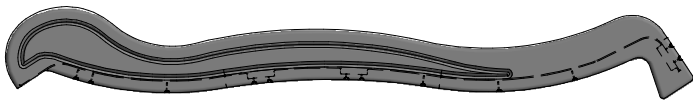

(1) EK - SLIDE RAIL 8' GREEN RIGHT - A100054



(1) EL - SLIDE RAIL 8' GREEN LEFT - A100055



(2) M78 - CENTER SLIDE BRACE - W100545
5/8"x3 3/8"x17 1/4" (16x86x438)

SLIDE ASSEMBLY STEP 2

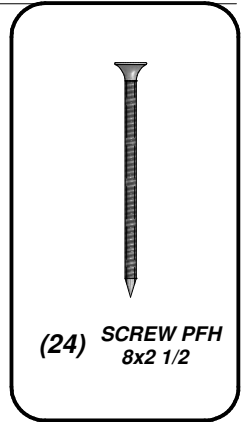
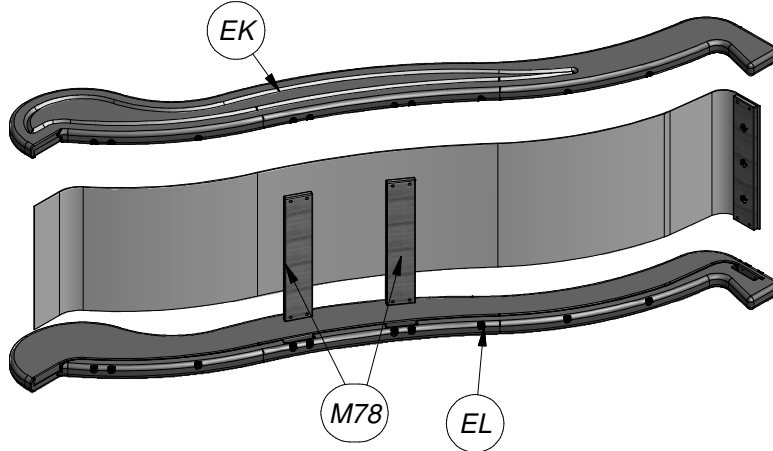

NOTE:

**MAKE CERTAIN
SUPPORTS AND SLIDE
BED ARE FULLY
ENGAGED WITHIN
CHANNEL OF SLIDE
RAILS.**

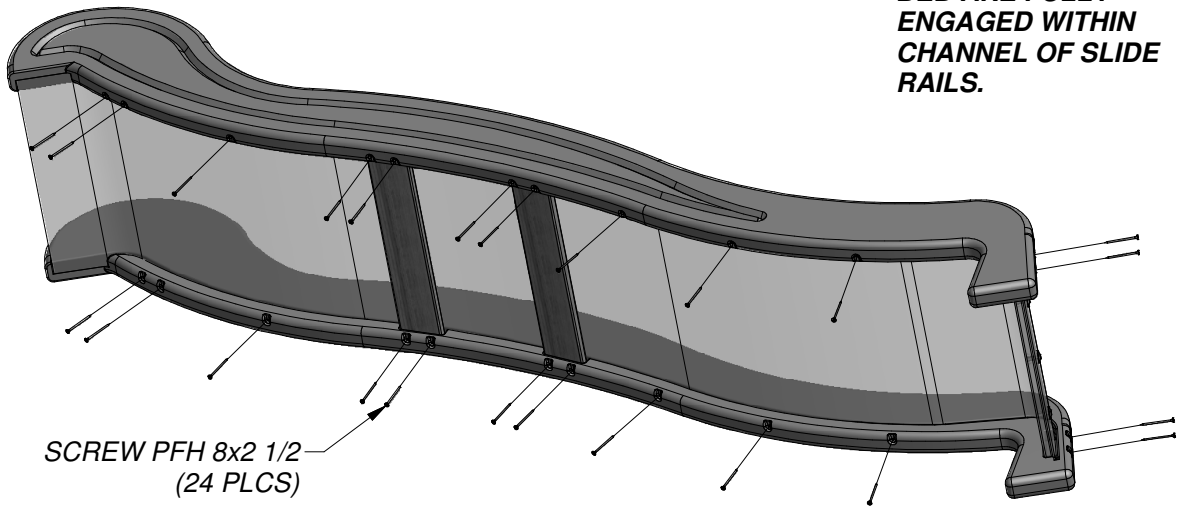

SCREW PFH 8x2 1/2
(24 PLCS)



TIP: A HELPER IS REQUIRED FOR THIS STEP.



(1) **K1 - GROUND BOARD - W4L06005**
5/8"x5 1/4"x72 3/4" (16x134x1848)

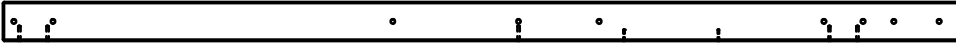

(1) **E1 - FORT UPRIGHT - W4L05999**
1 3/8"x3 3/8"x83" (36x86x2108)



(2) **M1 - ANGLE BRACE - W4L06001**
5/8"x3 3/8"x41 1/2" (16x86x1053)

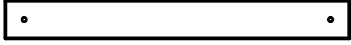

(1) **H4 - FLOOR JOIST - W102308**
1"x3 3/8"x30" (24x86x762)



(1) **M9 - SAFETY BOARD - W4L06006**
5/8"x3 3/8"x30" (16x86x762)



(1) **M6 - FLOOR SUPPORT - W102331**
5/8"x3 3/8"x30" (16x86x762)



(1) **E2 - FORT UPRIGHT - W2A01698**
1 3/8"x3 3/8"x83" (36x86x2108)

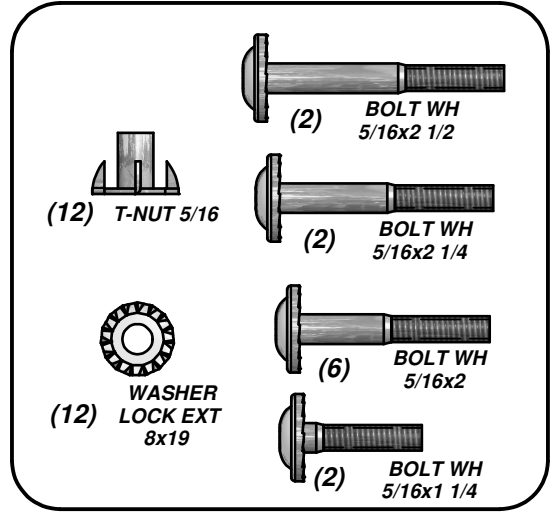

STEP 1

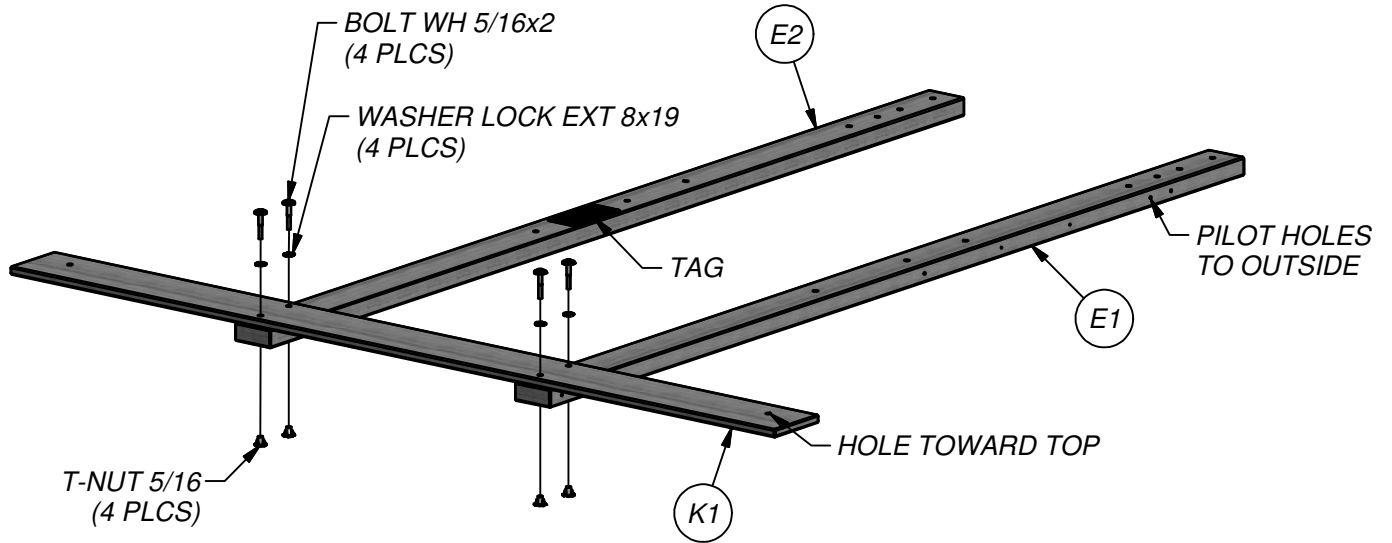

STEP 2

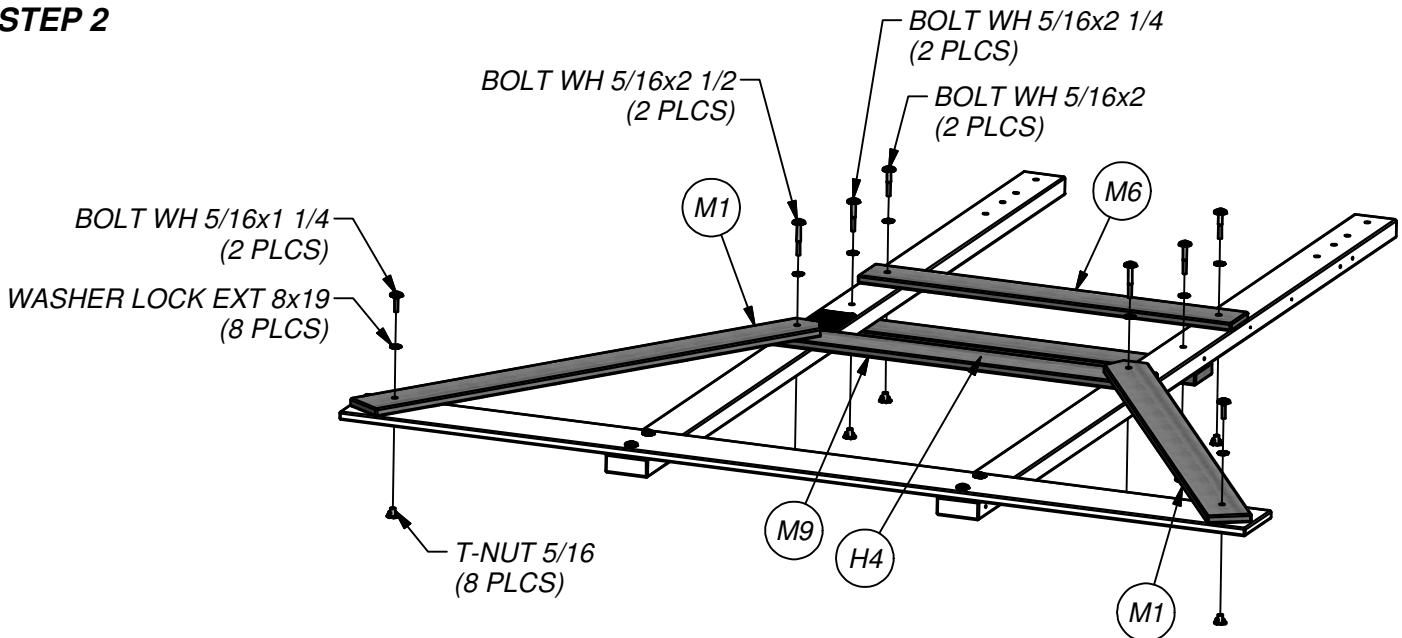



(1) E3 - FORT UPRIGHT - W4L05994
1 3/8"x3 3/8"x83" (36x86x2108)

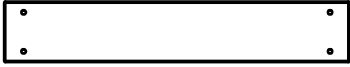

(2) K3 - WALL RAIL - W102302
5/8"x5 1/4"x30" (16x134x762)



(1) H5 - SWINGBEAM RAIL - W102303
1"x3 3/8"x30" (24x86x762)



(1) H7 - ROOF CROSS BRACE - W4L05909
1"x3 3/8"x62 1/2" (24x86x1588)



(1) E4 - FORT UPRIGHT - W4L06000
1 3/8"x3 3/8"x83" (36x86x2108)

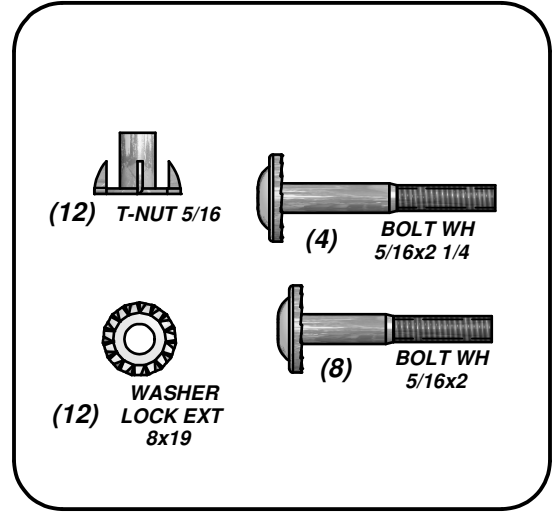

STEP 3

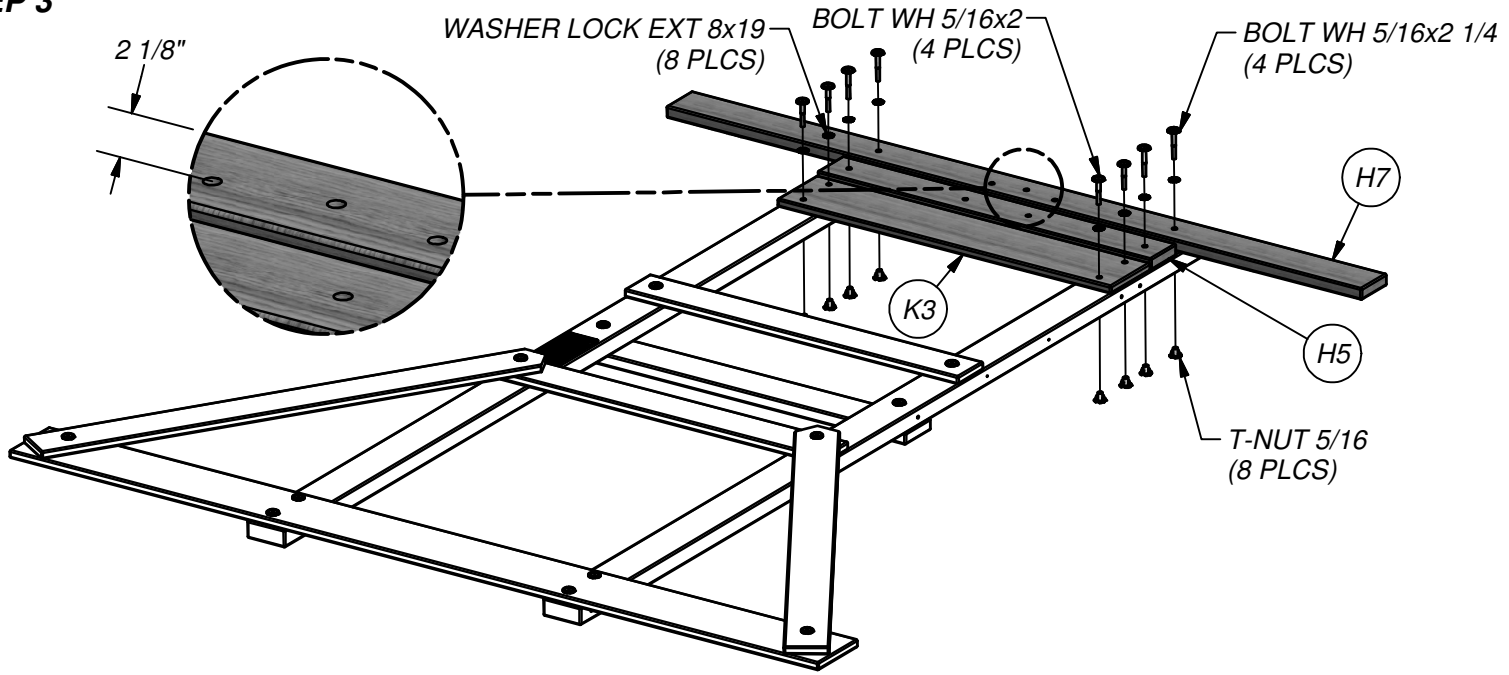

STEP 4

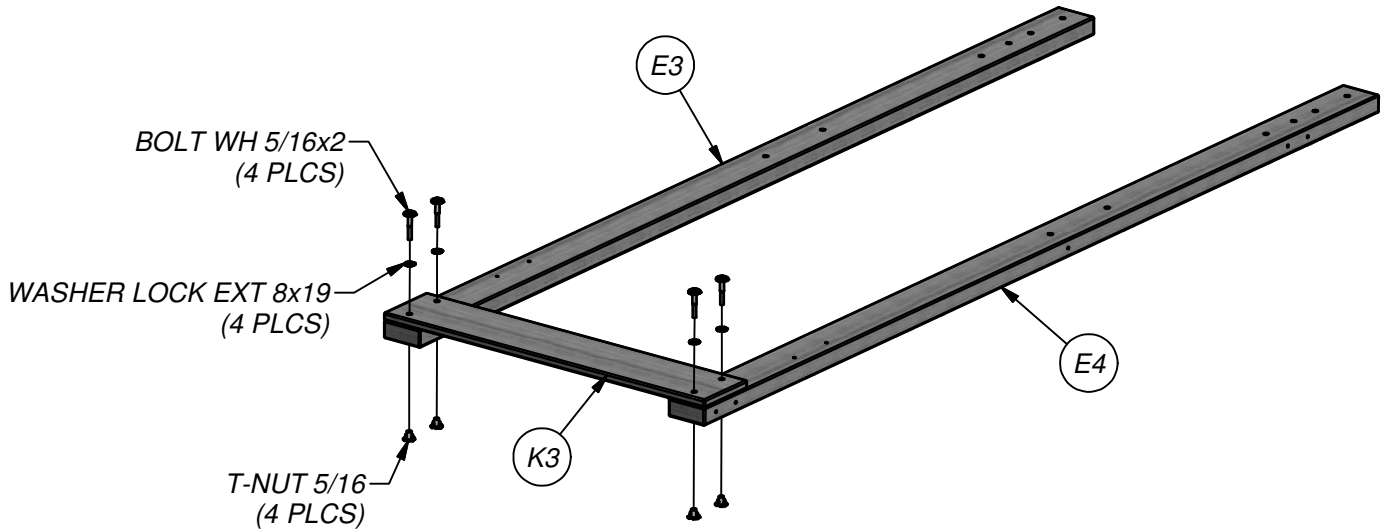

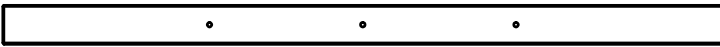

(1) **H1 - ROOF CROSS BRACE - W102301**
1"x3 3/8"x62 1/2" (24x86x1588)



(1) **K3 - WALL RAIL - W102302**
5/8"x5 1/4"x30" (16x134x762)

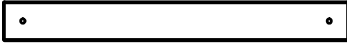

(1) **H4 - FLOOR JOIST - W102308**
1"x3 3/8"x30" (24x86x762)



(1) **M6 - FLOOR SUPPORT - W102331**
5/8"x3 3/8"x30" (16x86x762)



(1) **O1 - SAFETY BOARD - W102307**
5/8"x1 3/8"x30" (16x34x762)

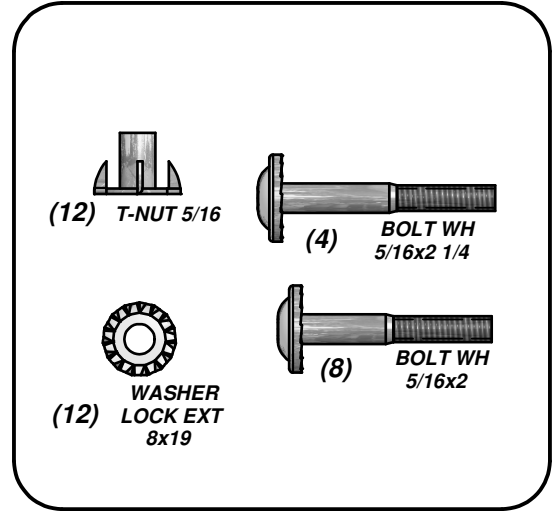

STEP 5

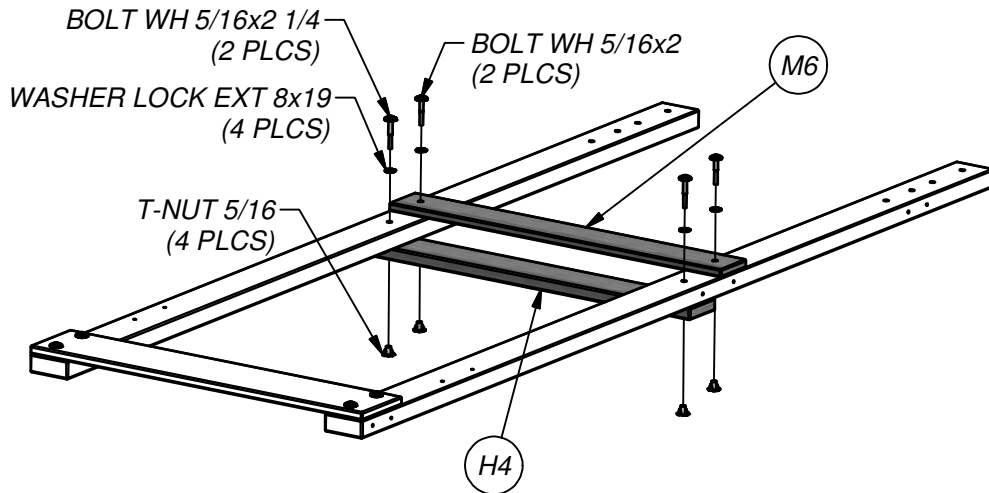

STEP 6

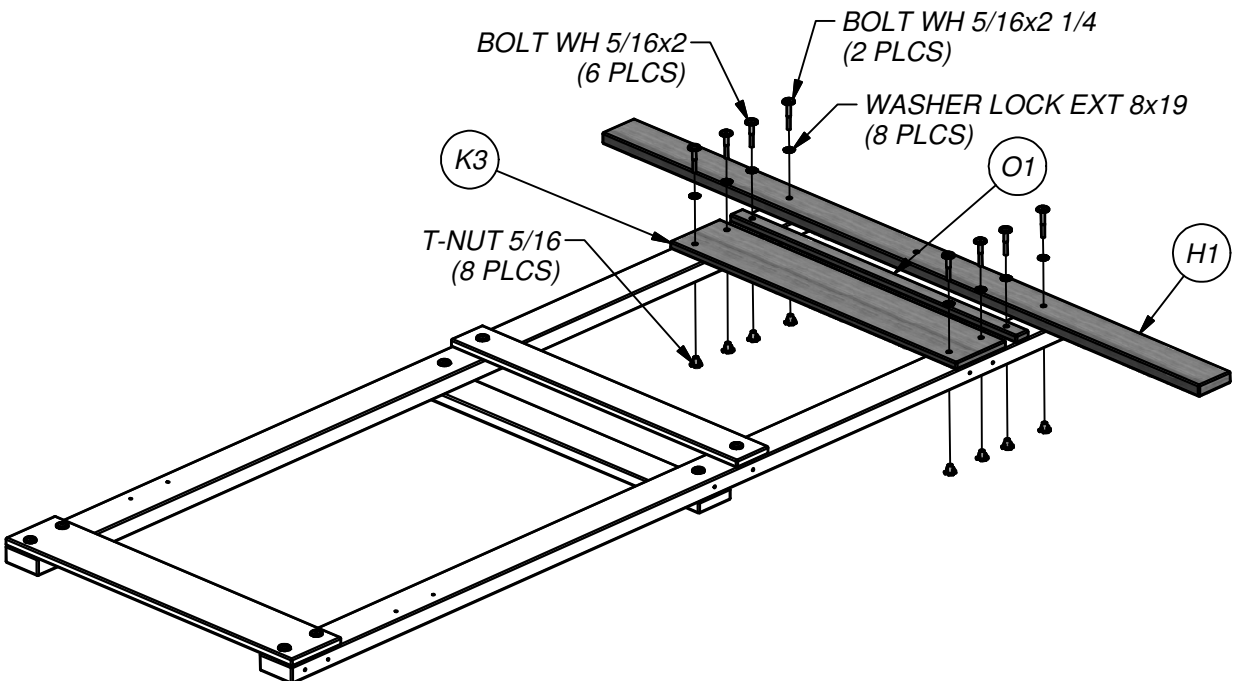



(2) **K2 - GROUND BOARD - W4L05997**
5/8"x5 1/4"x52 1/2" (16x134x1334)

STEP 7

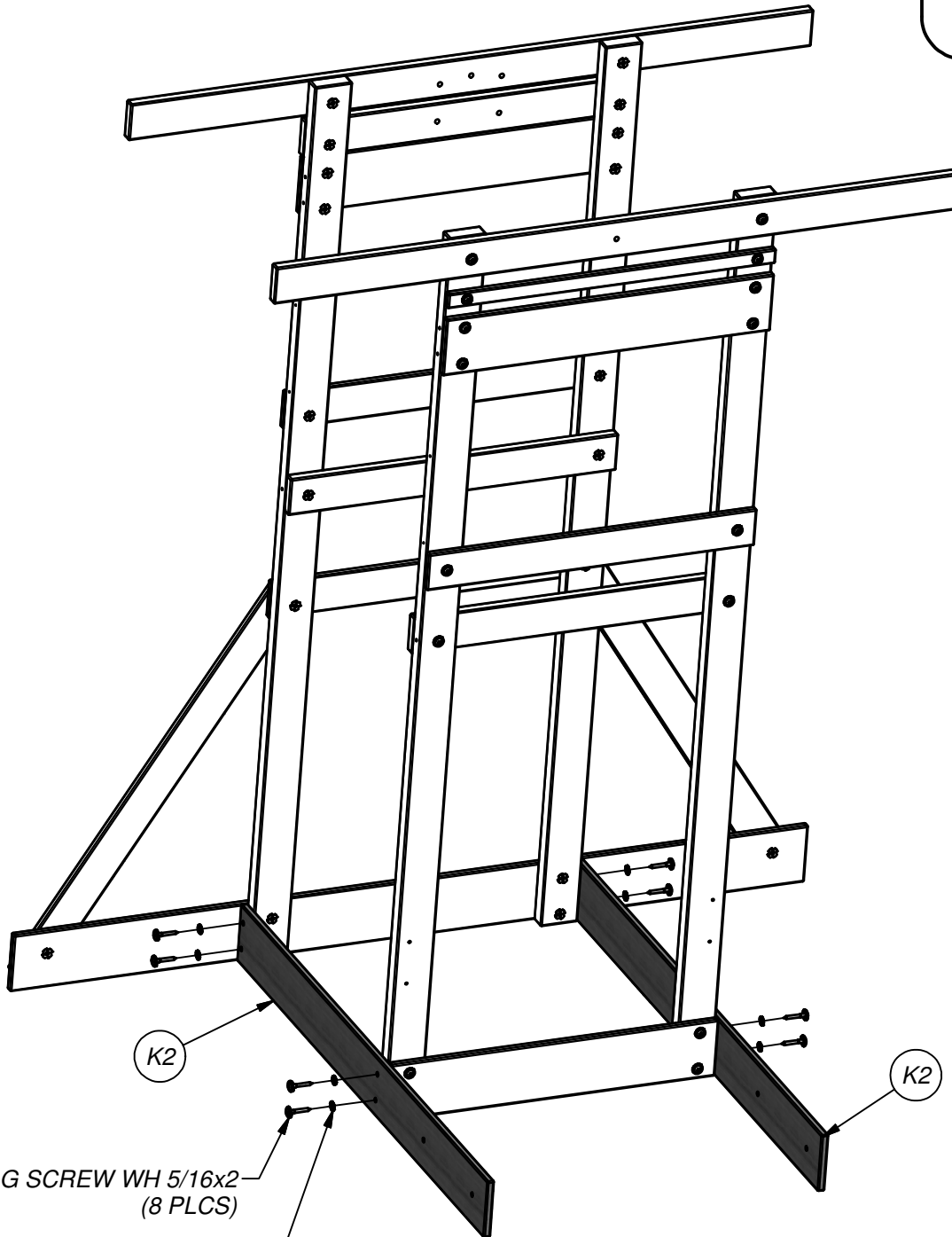
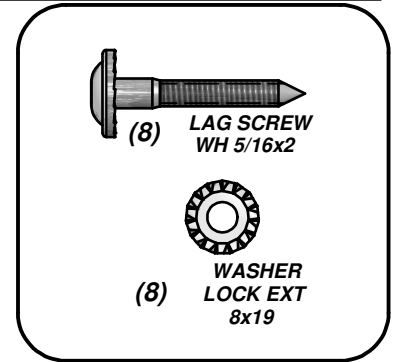

K2

K2

LAG SCREW WH 5/16x2
(8 PLCS)

WASHER LOCK EXT 8x19
(8 PLCS)



(1) M7 - FLOOR SUPPORT - W4L06003
5/8"x3 3/8"x30" (16x86x762)

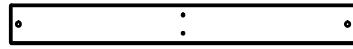

(1) M5 - FLOOR SUPPORT - W102309
5/8"x3 3/8"x30" (16x86x762)

STEP 8

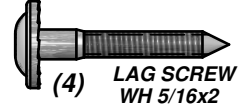

(4) LAG SCREW
WH 5/16x2



(4) WASHER
LOCK EXT
8x19

WASHER LOCK EXT 8x19
(4 PLCS)

LAG SCREW WH 5/16x2
(4 PLCS)

M7

M5

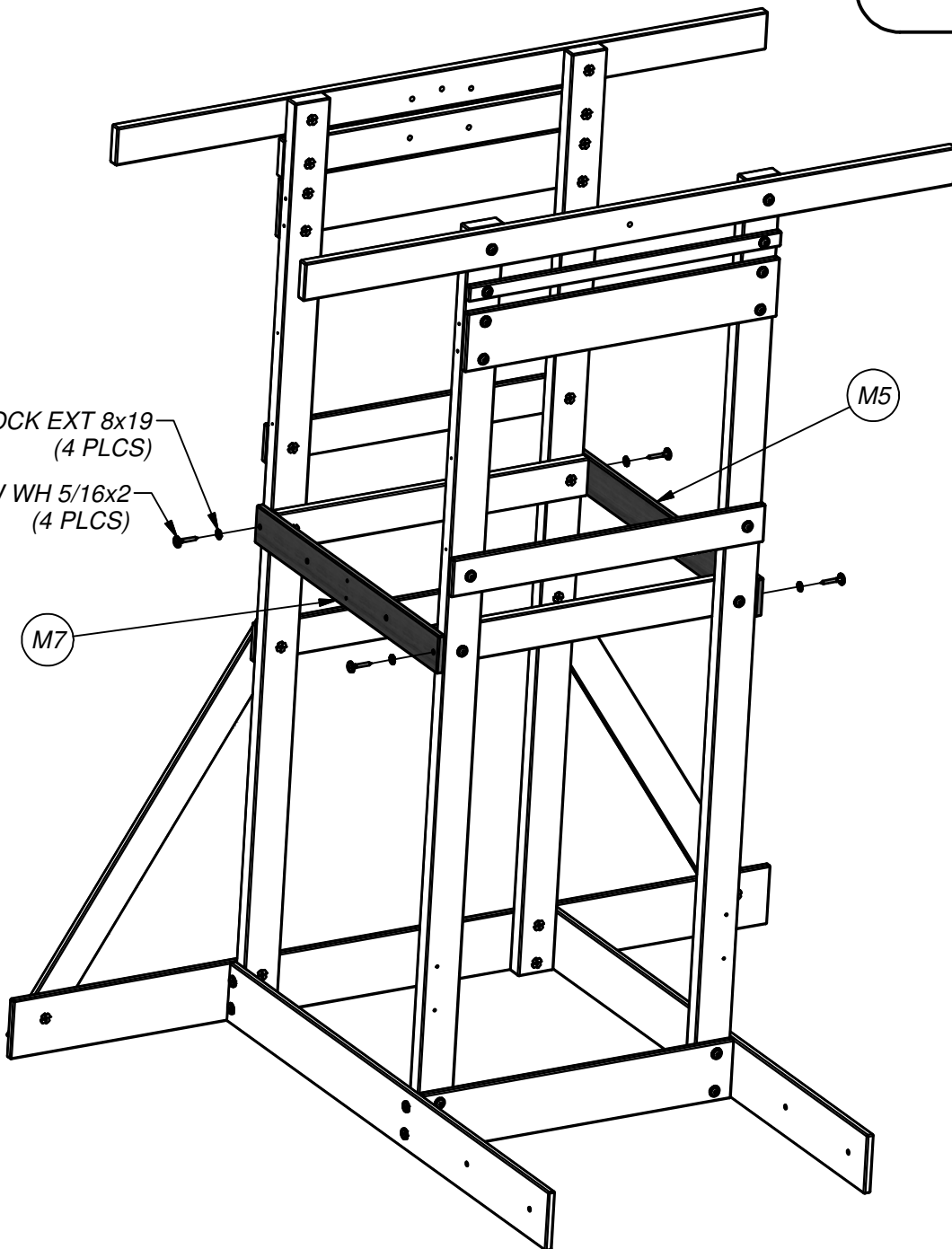



(2) **M2 - TARP SUPPORT - W102337**
5/8"x3 3/8"x31 7/8" (16x86x810)



(2) **K4 - ARCHED WALL RAIL - W102306**
5/8"x5 1/4"x30" (16x134x762)

STEP 9

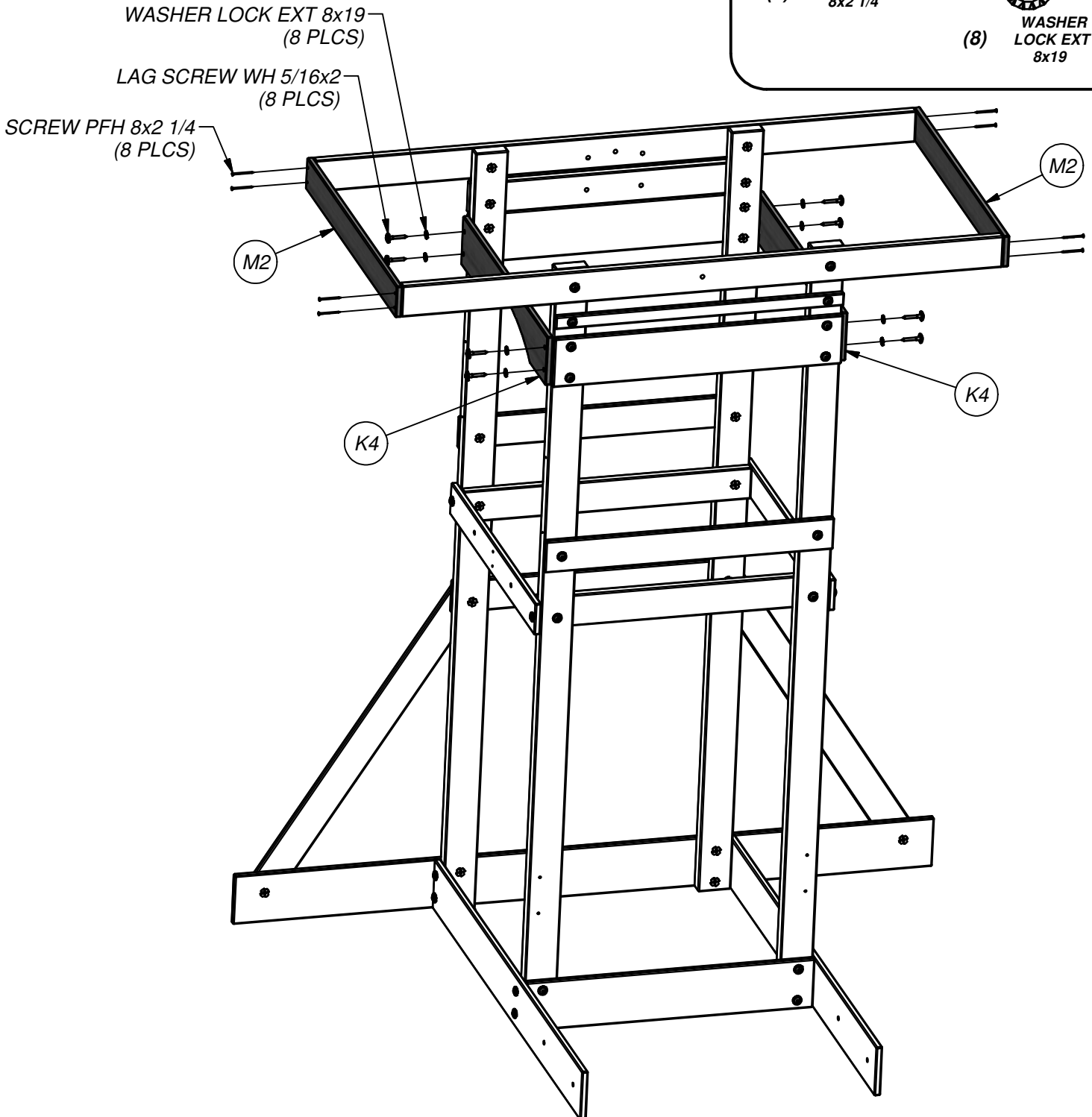
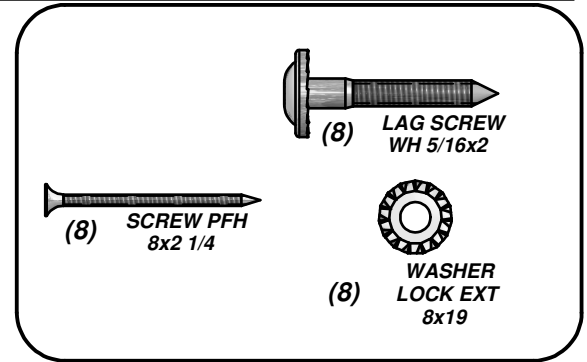

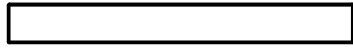

(1) H6 - FLOOR SUPPORT - W102338
1"x3 3/8"x30" (24x86x762)



(1) SR - "B" REVISION TAG - A100315

STEP 10

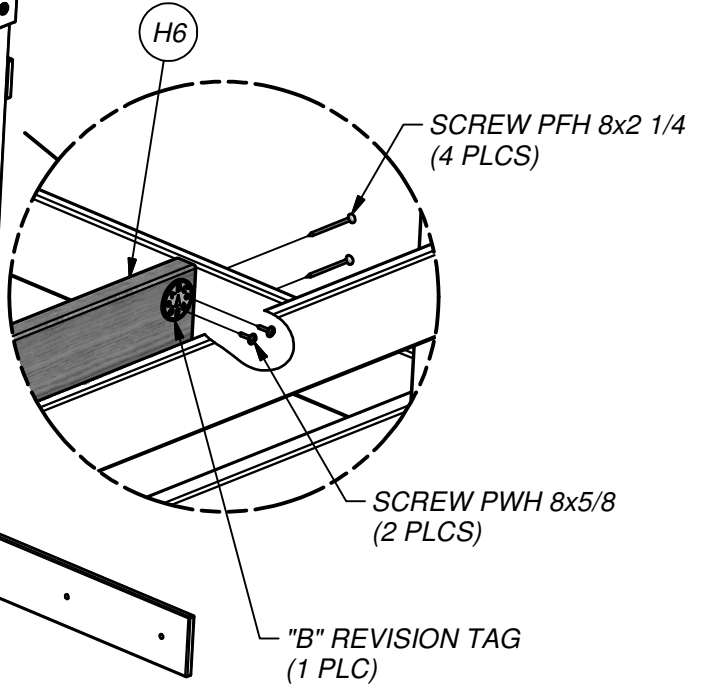
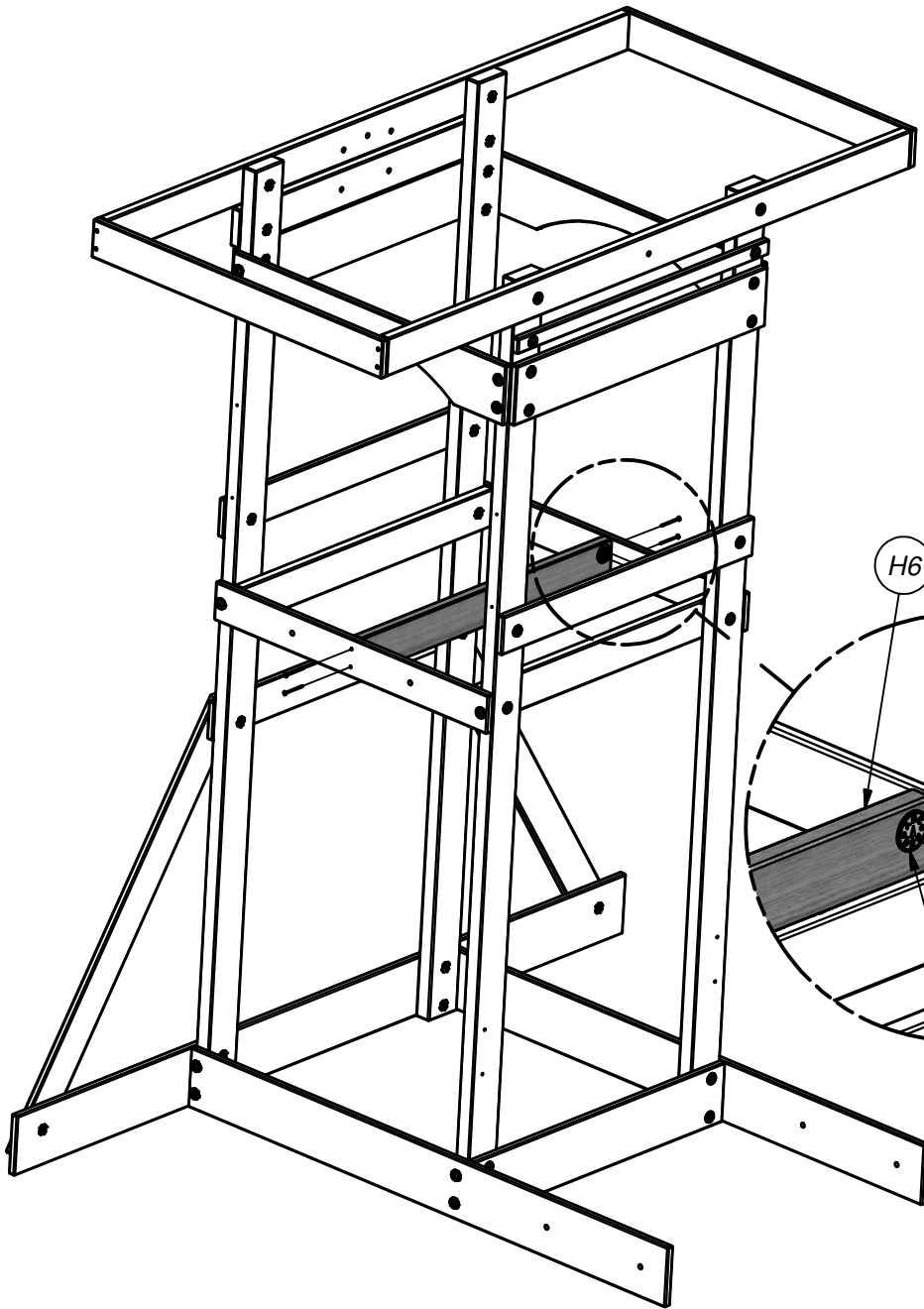
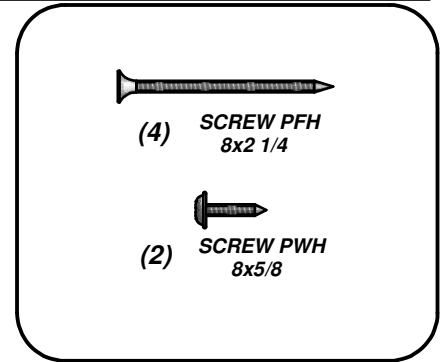

H6

SCREW PFH 8x2 1/4
(4 PLCS)

SCREW PWH 8x5/8
(2 PLCS)

"B" REVISION TAG
(1 PLC)



(2) **K5 - OUTER FLOOR BOARD - W102333**
5/8"x5 1/4"x27 1/8" (16x134x688)

STEP 11

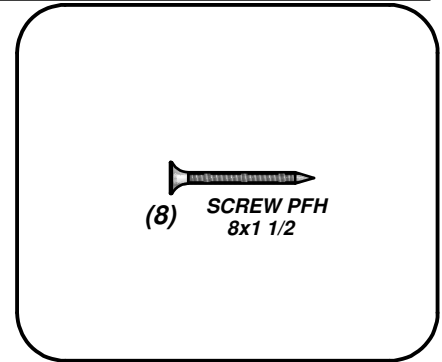

SCREW PFH 8x1 1/2
(8 PLCS)

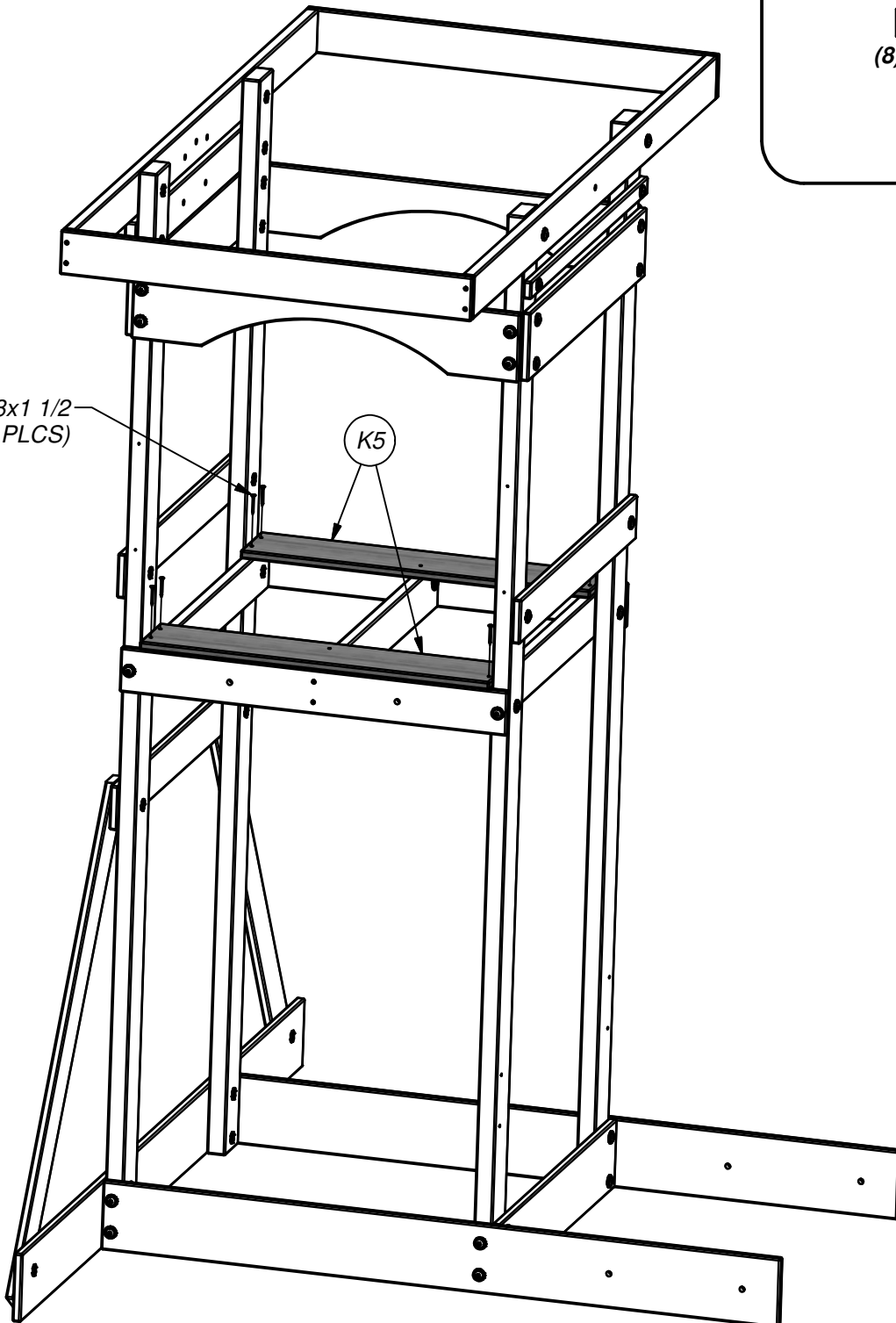



(6) **M4 - FLOOR BOARD - W102332**
5/8"x3 3/8"x30 7/8" (16x86x785)

STEP 12

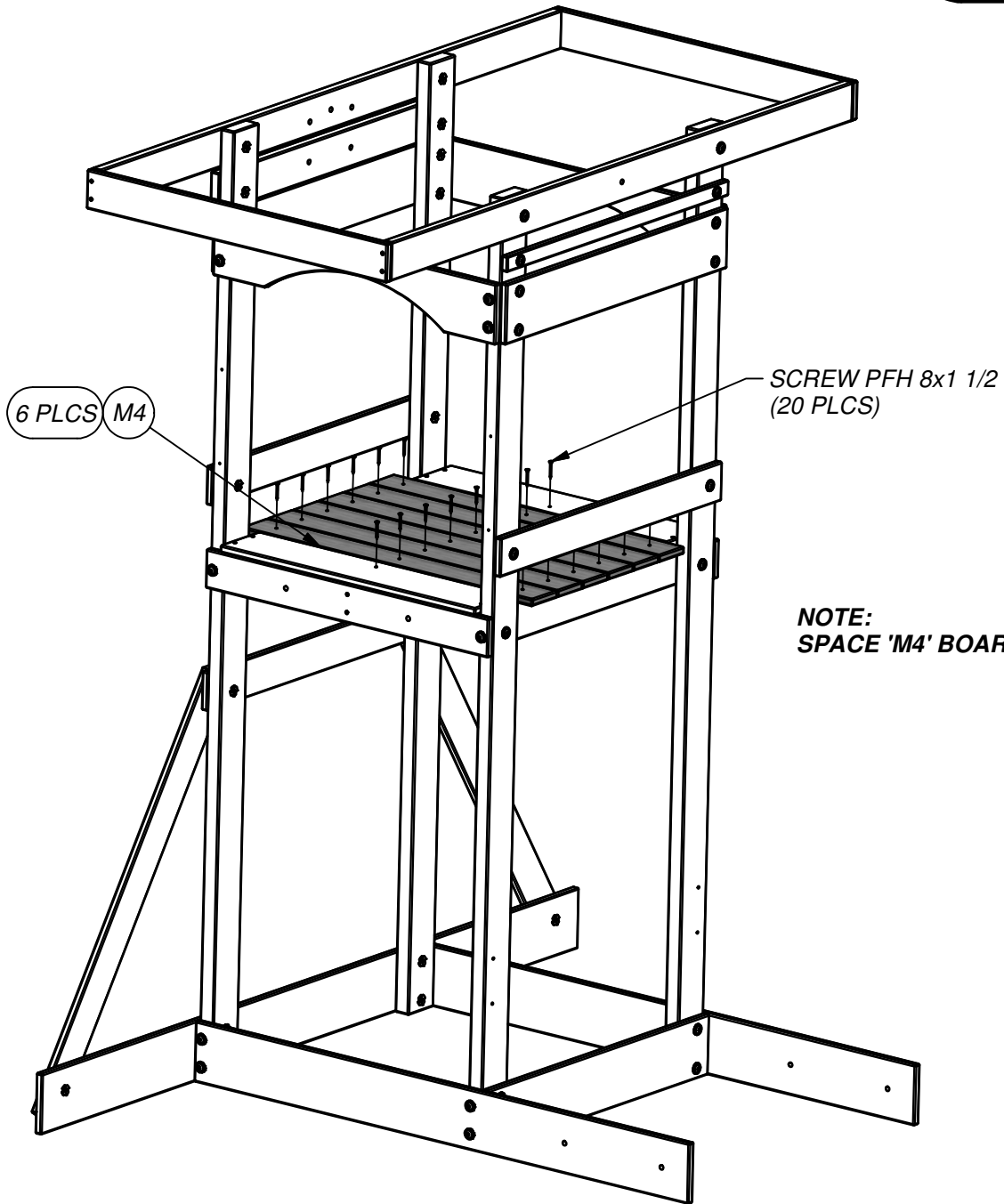
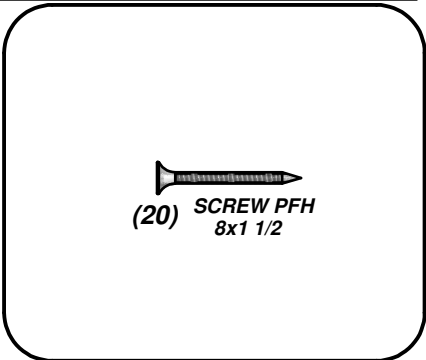

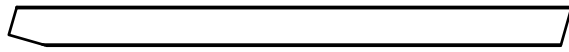

(2) H2 - ROCKWALL SUPPORT - W102334
1"x3 3/8"x48 7/8" (24x86x1242)

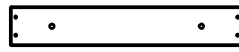

(1) M12 - ROCKWALL BOARD - W4L06004
5/8"x3 3/8"x20 1/4" (16x86x514)



(3) - GREEN HC ROCK #1 - A6P00036



(6) M11 - ROCKWALL BOARD - W4L06002
5/8"x3 3/8"x20 1/4" (16x86x514)

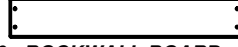

(2) M10 - ROCKWALL BOARD - W102335
5/8"x3 3/8"x20 1/4" (16x86x514)



(3) - GREEN HC ROCK #2 - A6P00037

STEP 13

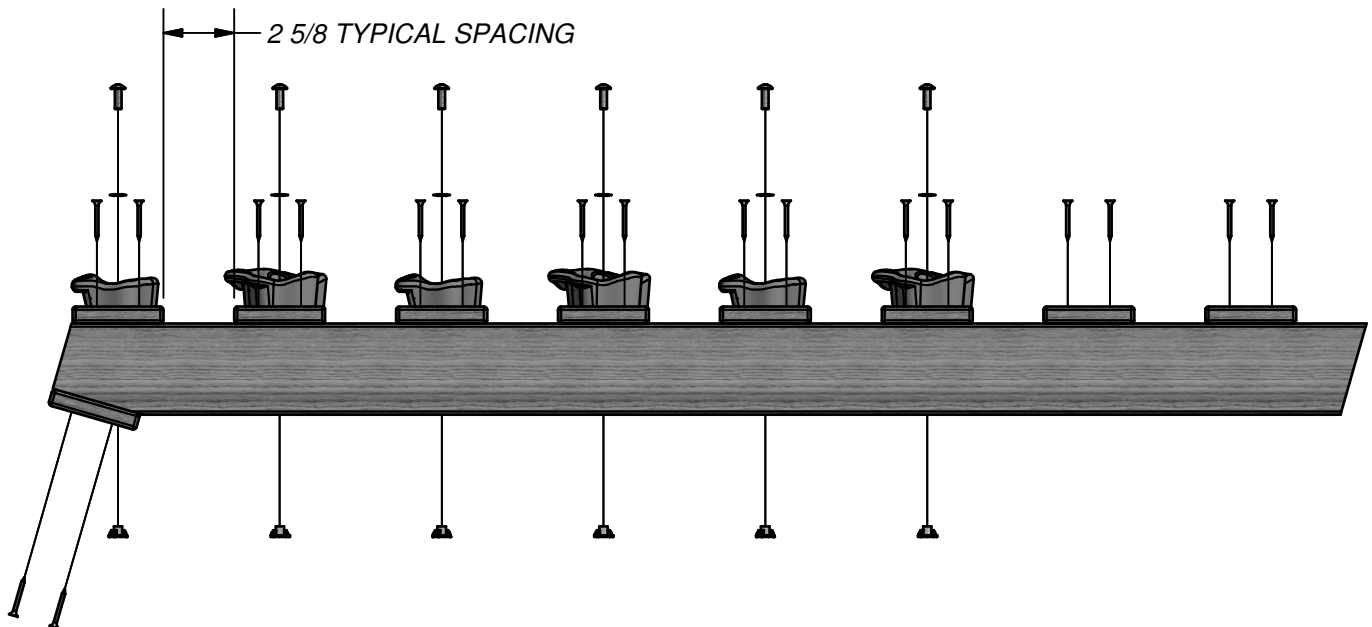
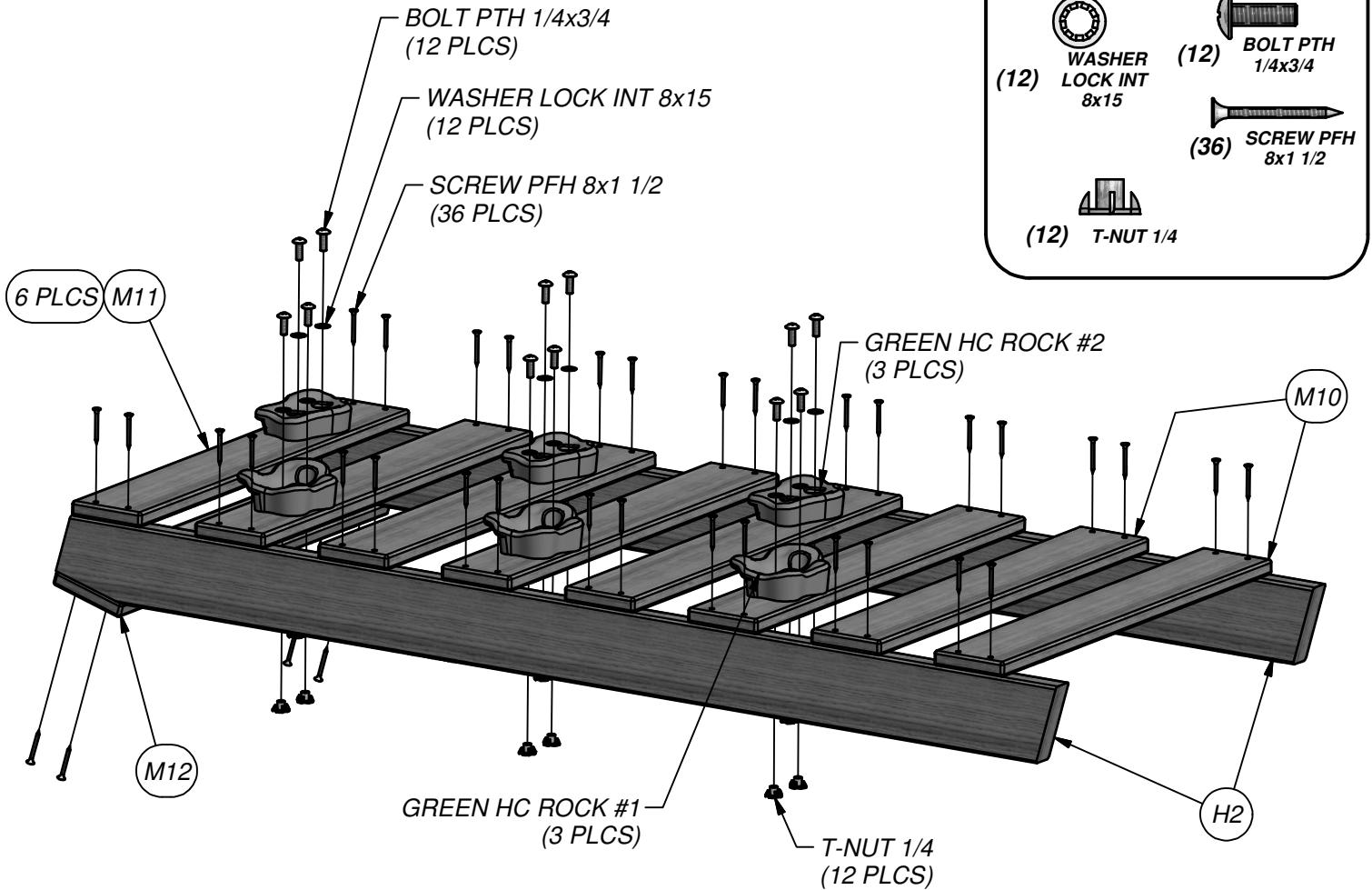

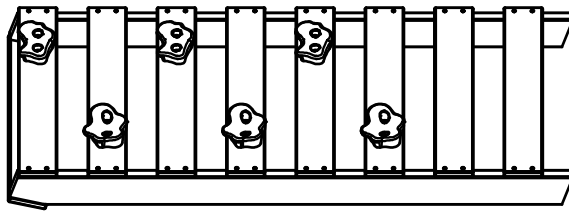

ROCK LADDER ASSEMBLY

STEP 14

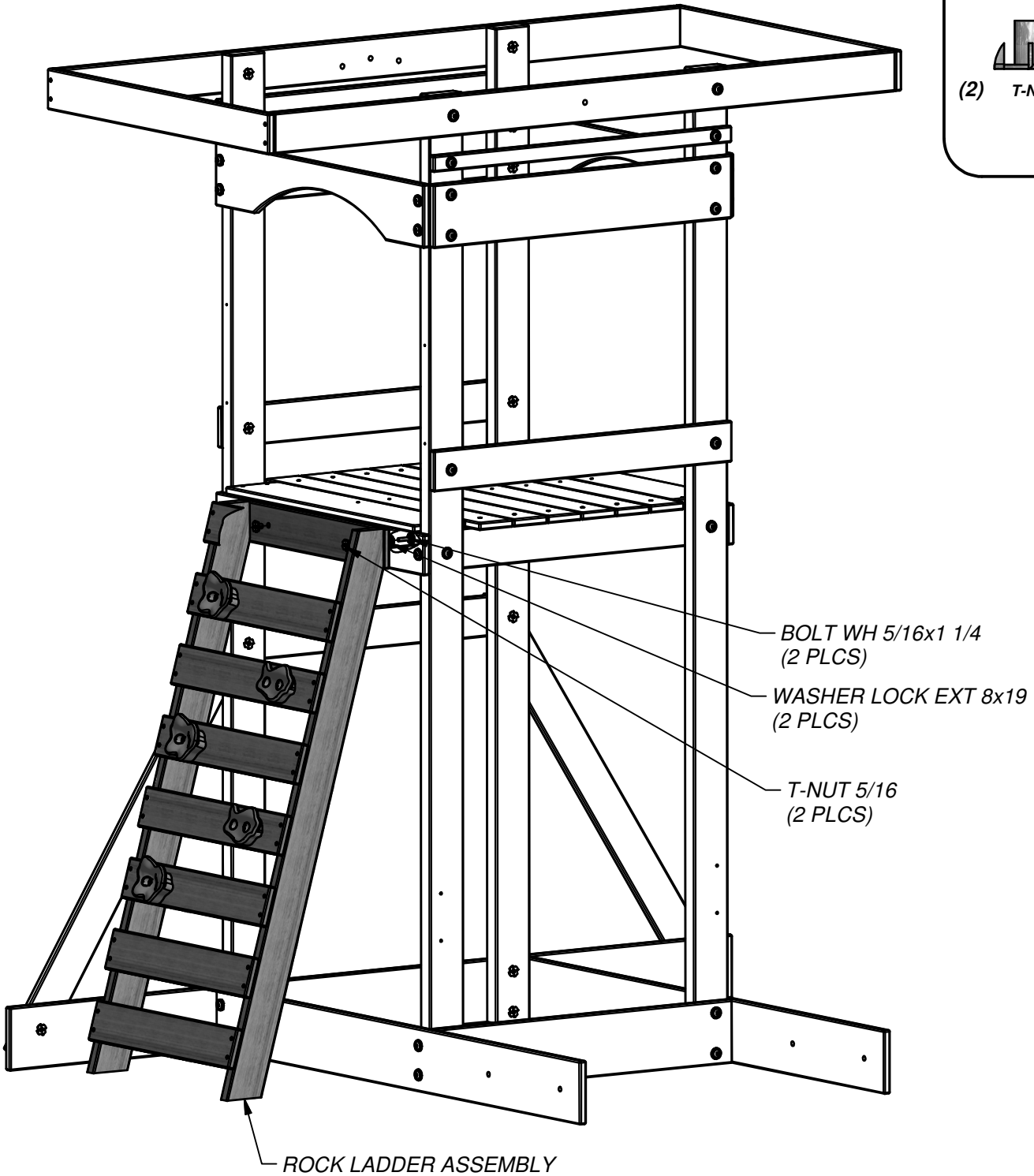
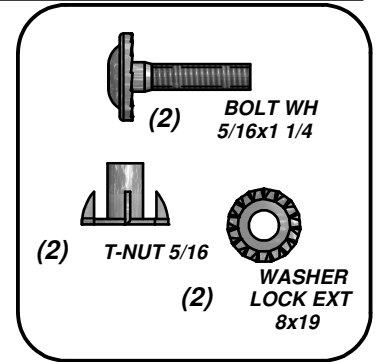



(3) M49 - PICKET - 53 - W4L05374
5/8"x3 3/8"x20 3/8" (16x86x518)

STEP 15

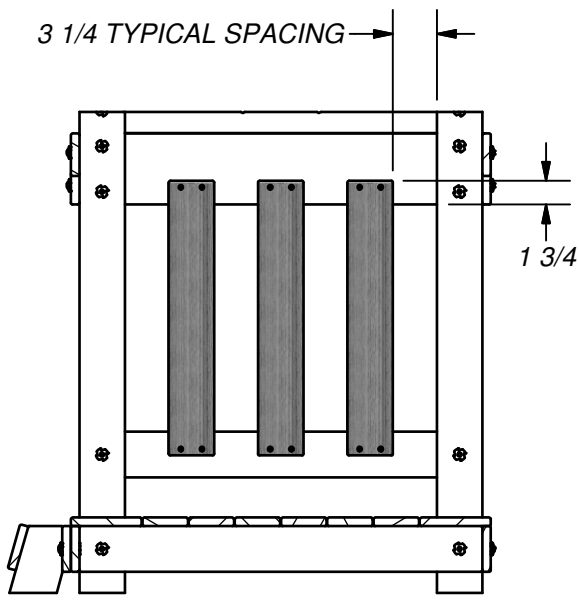
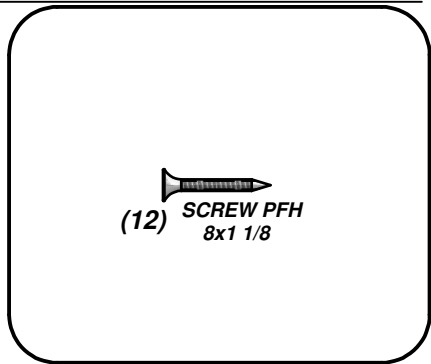
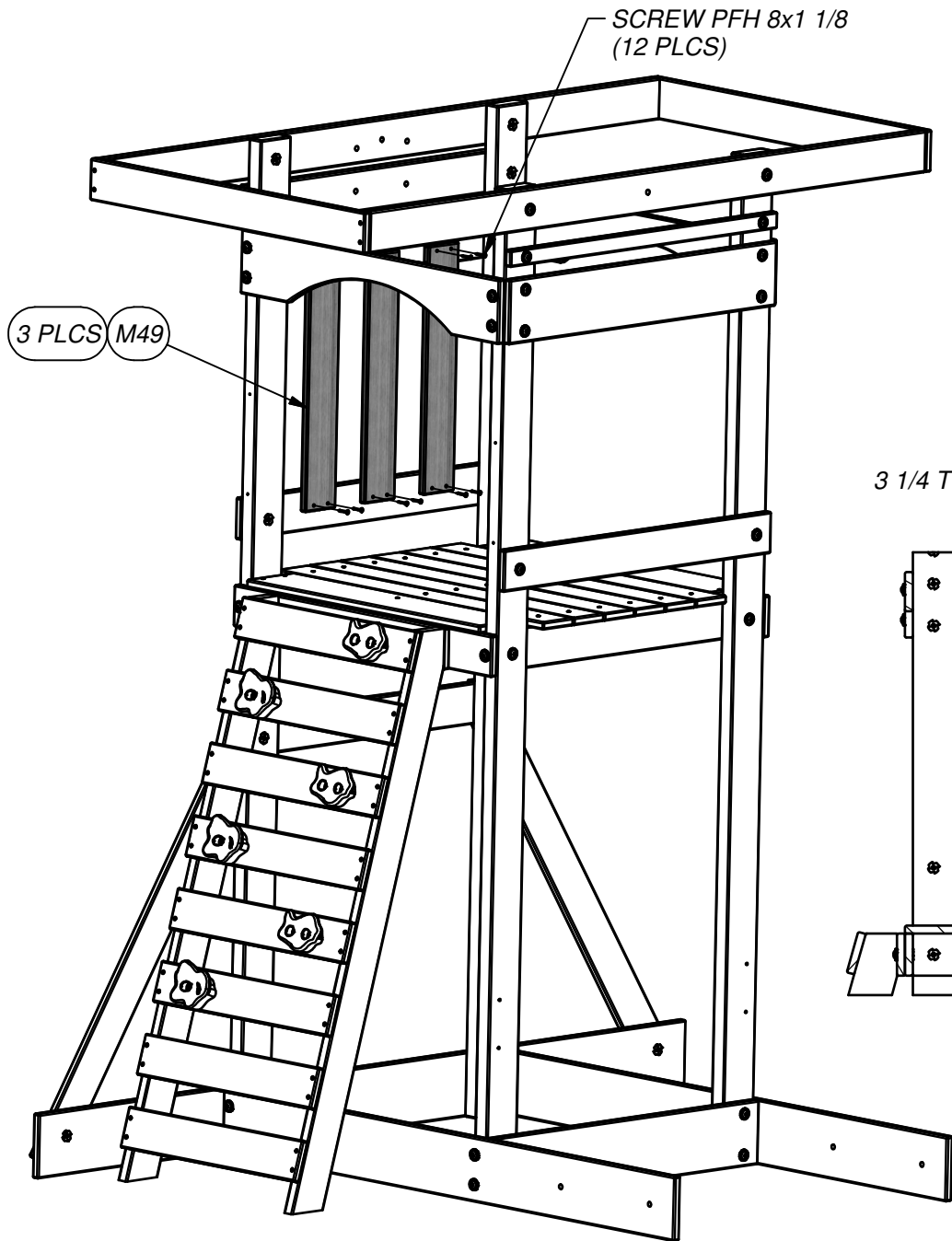



(3) M49 - PICKET - 53 - W4L05374
5/8" x 3 3/8" x 20 3/8" (16x86x518)

STEP 16

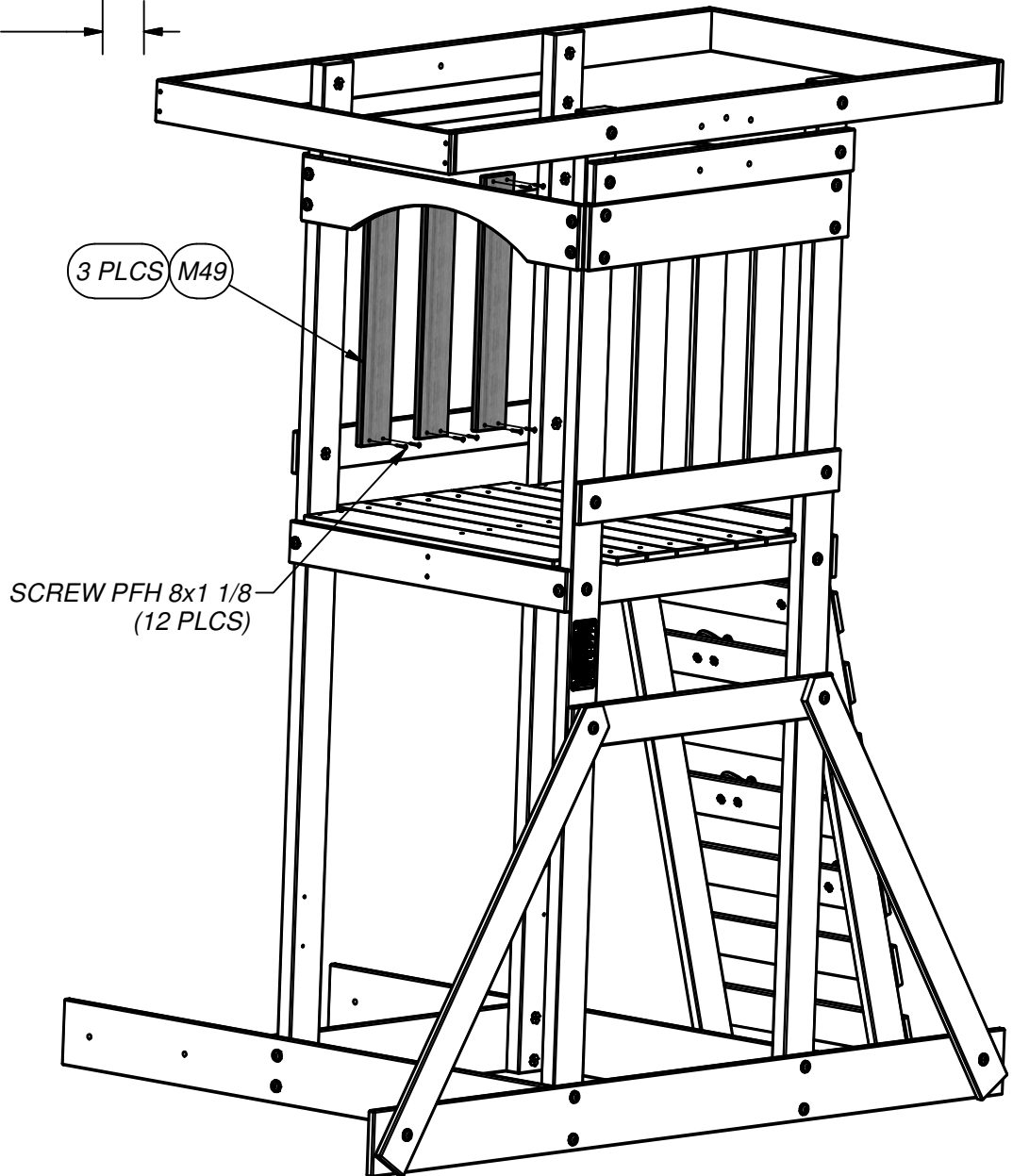
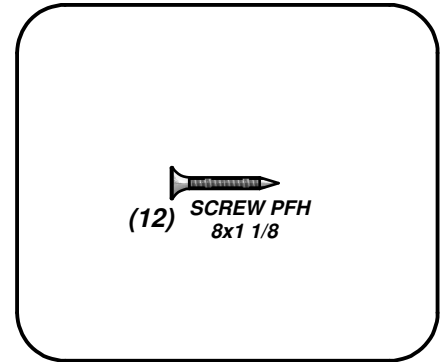
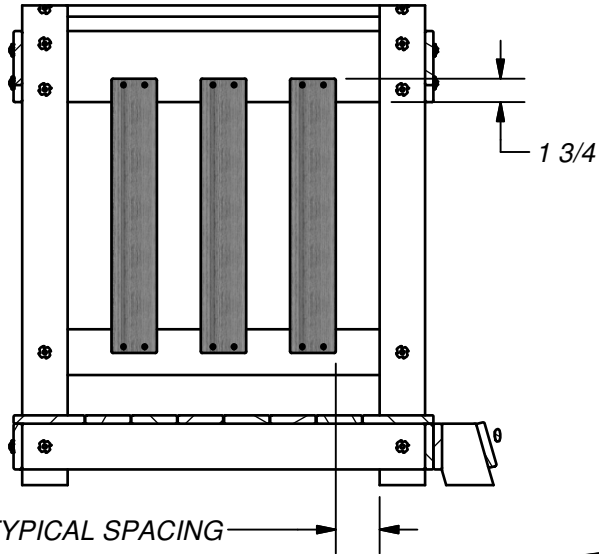



(2) **H3 - TARP UPRIGHT - W102340**
1"x3 3/8"x37" (24x86x940)



(1) **M8 - TARP SUPPORT - W102341**
5/8"x3 3/8"x30" (16x86x762)

STEP 17

SCREW PFH 8x2 1/4
(4 PLCS)

M8

H3

T-NUT 5/16
(2 PLCS)

WASHER LOCK EXT 8x19
(2 PLCS)

BOLT WH 5/16x1 3/4
(2 PLCS)

SCREW PFH 8x1 1/2
(4 PLCS)

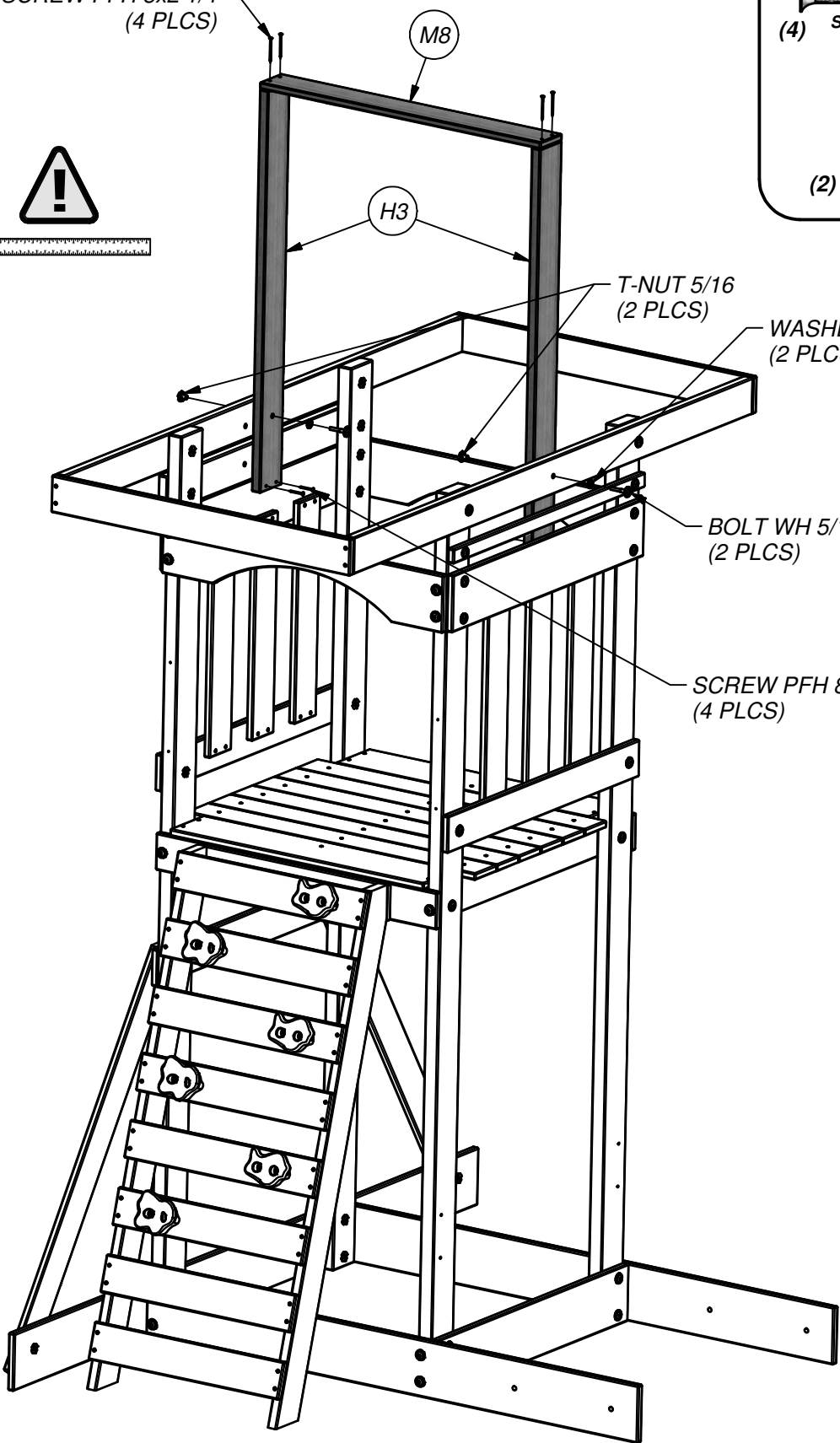
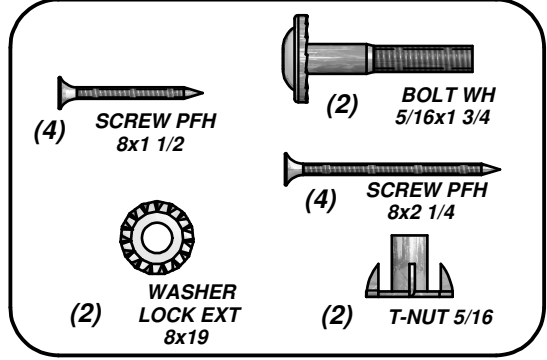

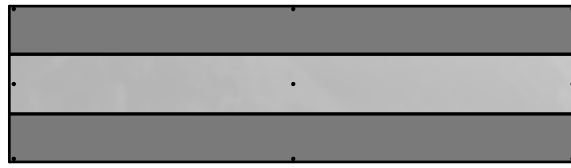

(1) UA - TARP .4x686x2506 - A100341
1/64"x27"x98 5/8" (.4x686x2506)

STEP 18

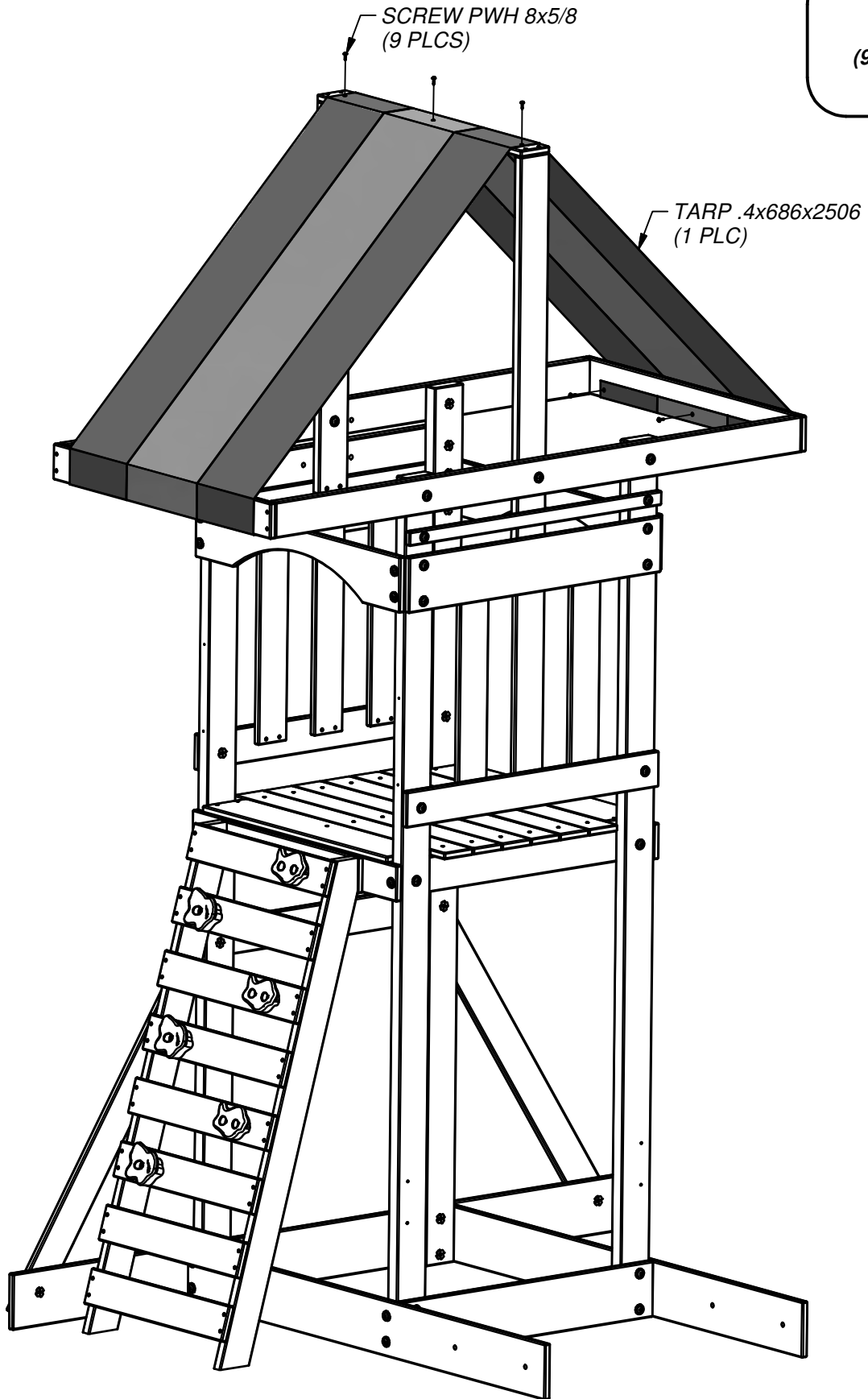
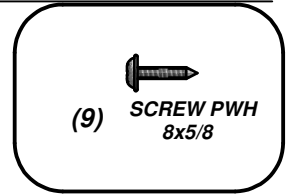

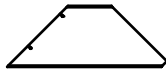

(2) **G1 - PICNIC TOP SUPPORT - W4L05998**
1"x5 1/4"x13 7/8" (24x134x352)

STEP 19

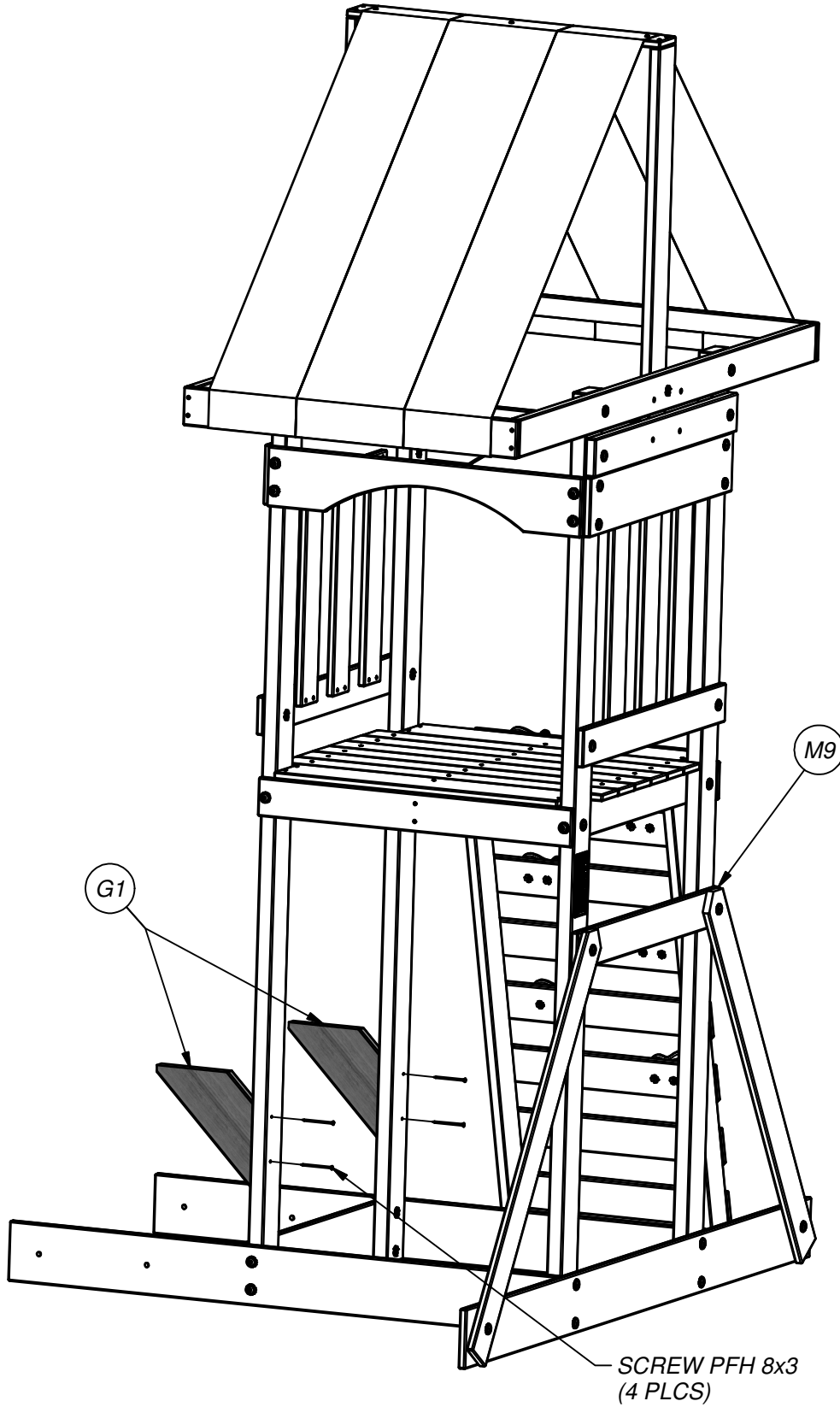
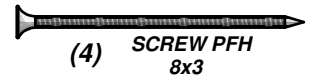

(2) **M3 - PICNIC SEAT/TOP - W102347**
5/8"x3 3/8"x31" (16x86x786)

(1) **N3 - TIE STRAP - W102344**
5/8"x2 3/8"x6" (16x60x152)

STEP 20

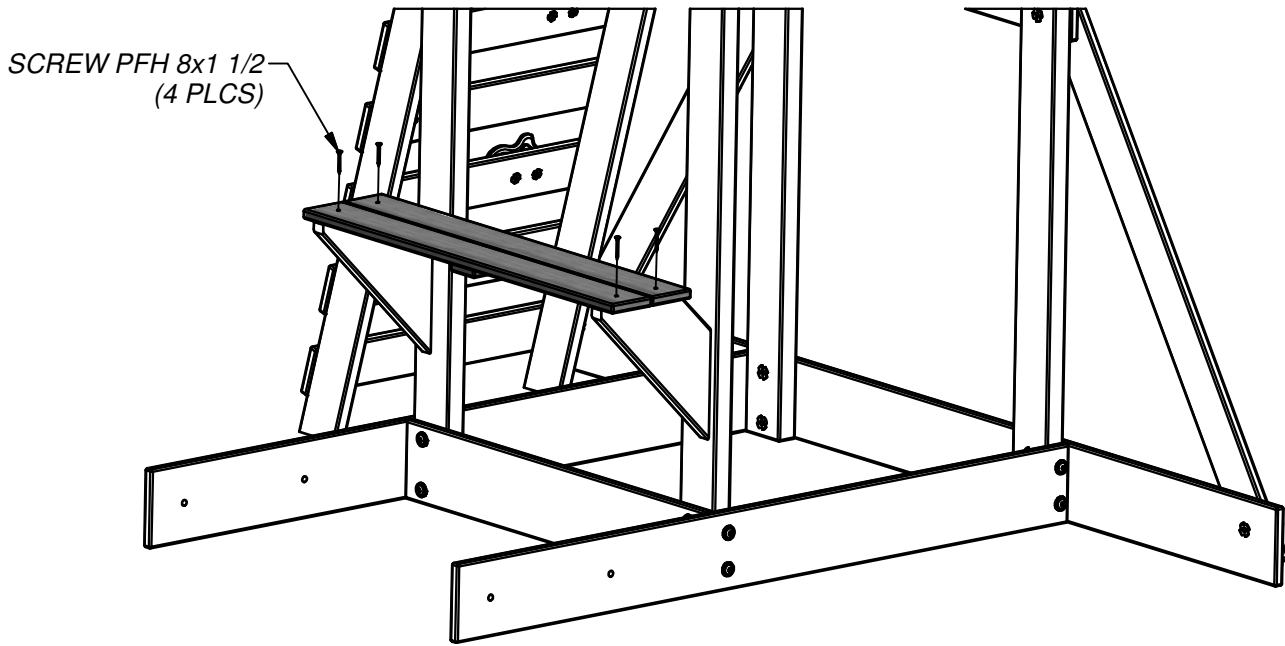
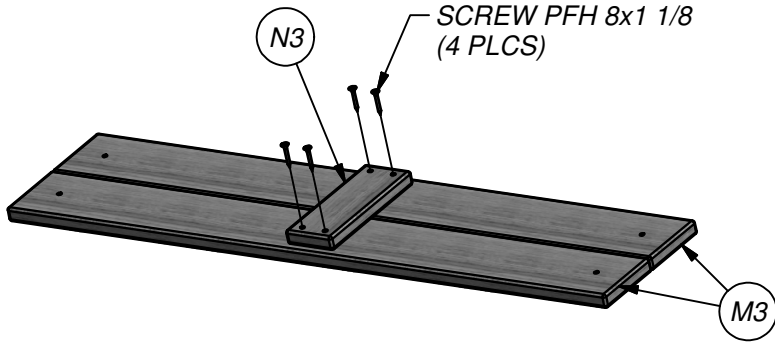
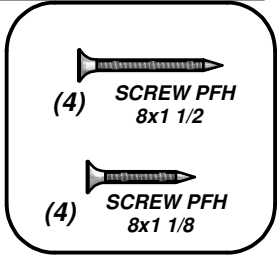

(4) **N2 - PICNIC TABLE BRACE - W4L05995**
 5/8"x2 3/8"x12" (16x60x305)

(2) **J1 - TIE STRAP - W4L05996**
 1"x2 3/8"x7" (24x60x178)

STEP 21

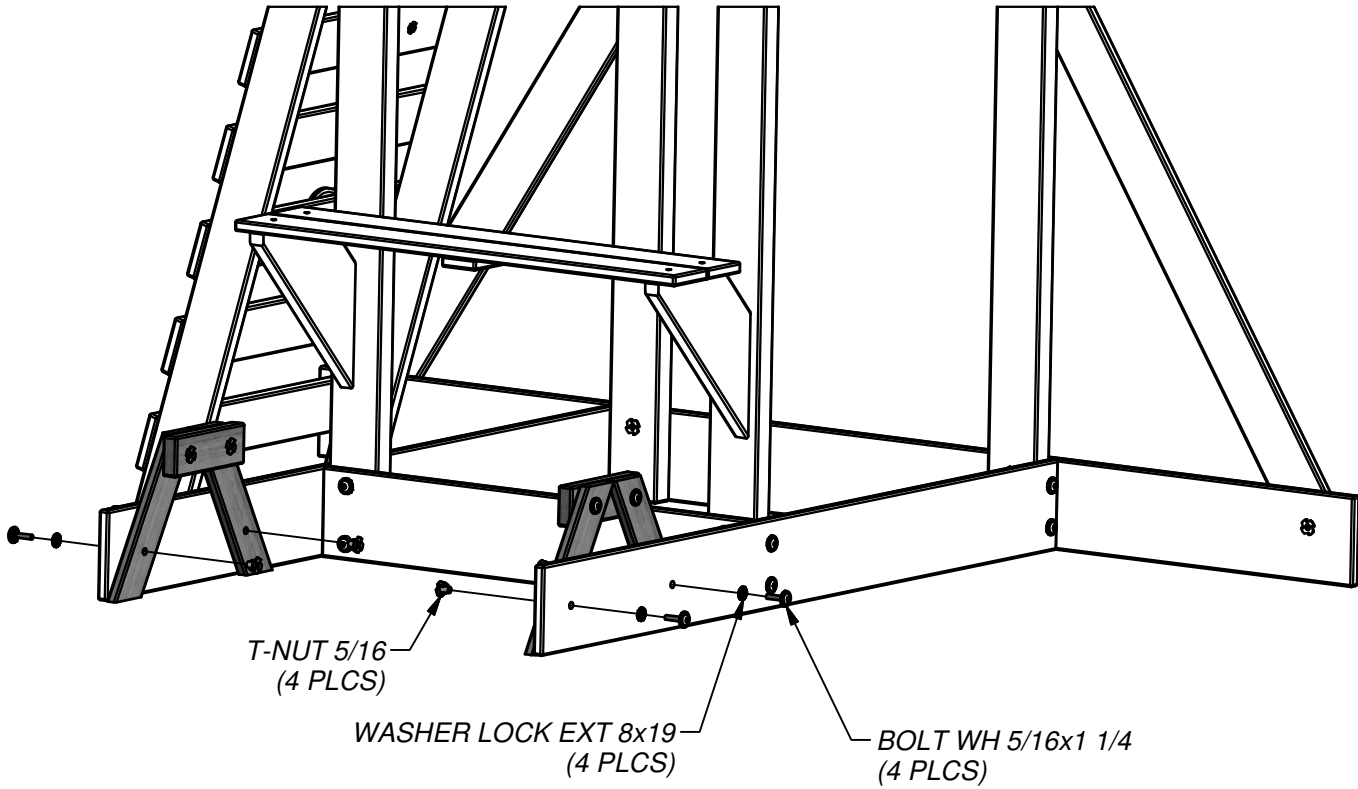
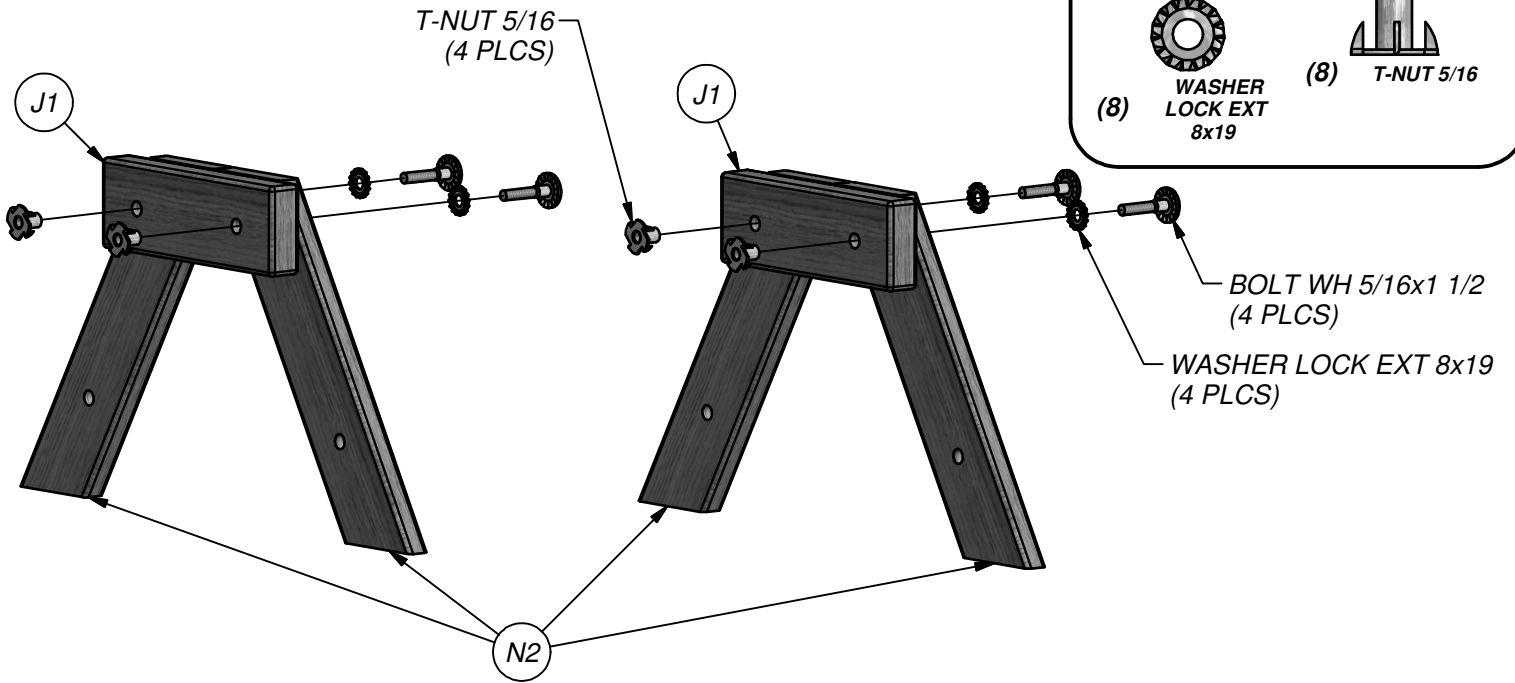



(2) **M3 - PICNIC SEAT/TOP - W102347**
5/8"x3 3/8"x31" (16x86x786)



(1) **N3 - TIE STRAP - W102344**
5/8"x2 3/8"x6" (16x60x152)

STEP 22

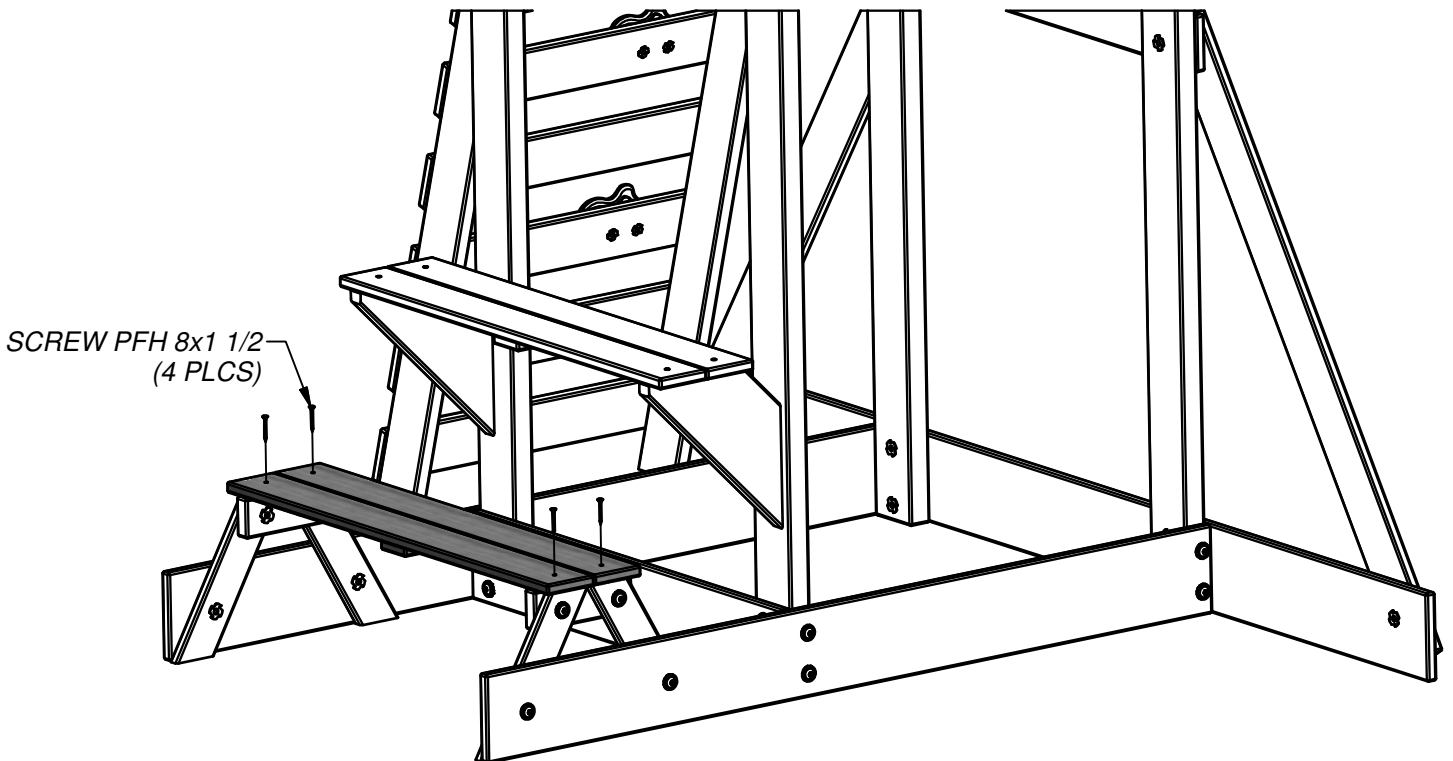
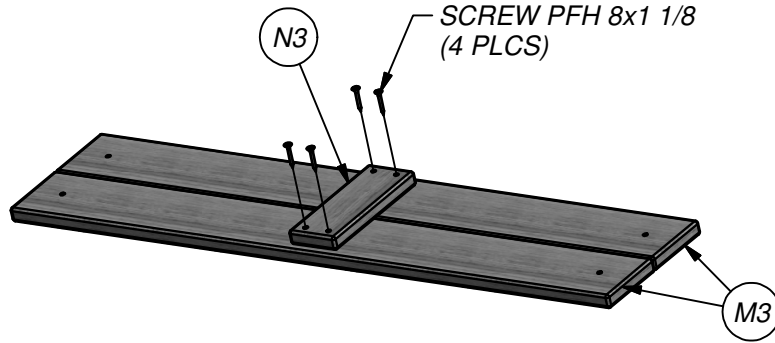
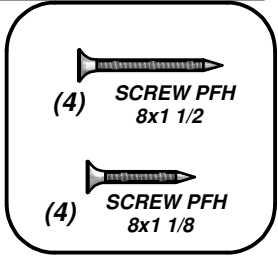

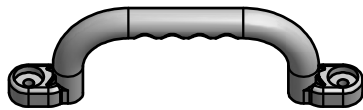



(2) EA - HAND GRIP YELLOW PLASTIC - A100043

STEP 23

(4) SCREW
TAPPING
14x1-1/2

(4) WASHER
LOCK INT
8x15



(4) WASHER
FLAT 9x18

WASHER FLAT 9x18
(4 PLCS)

WASHER LOCK INT 8x15
(4 PLCS)

SCREW TAPPING 14x1-1/2
(4 PLCS)

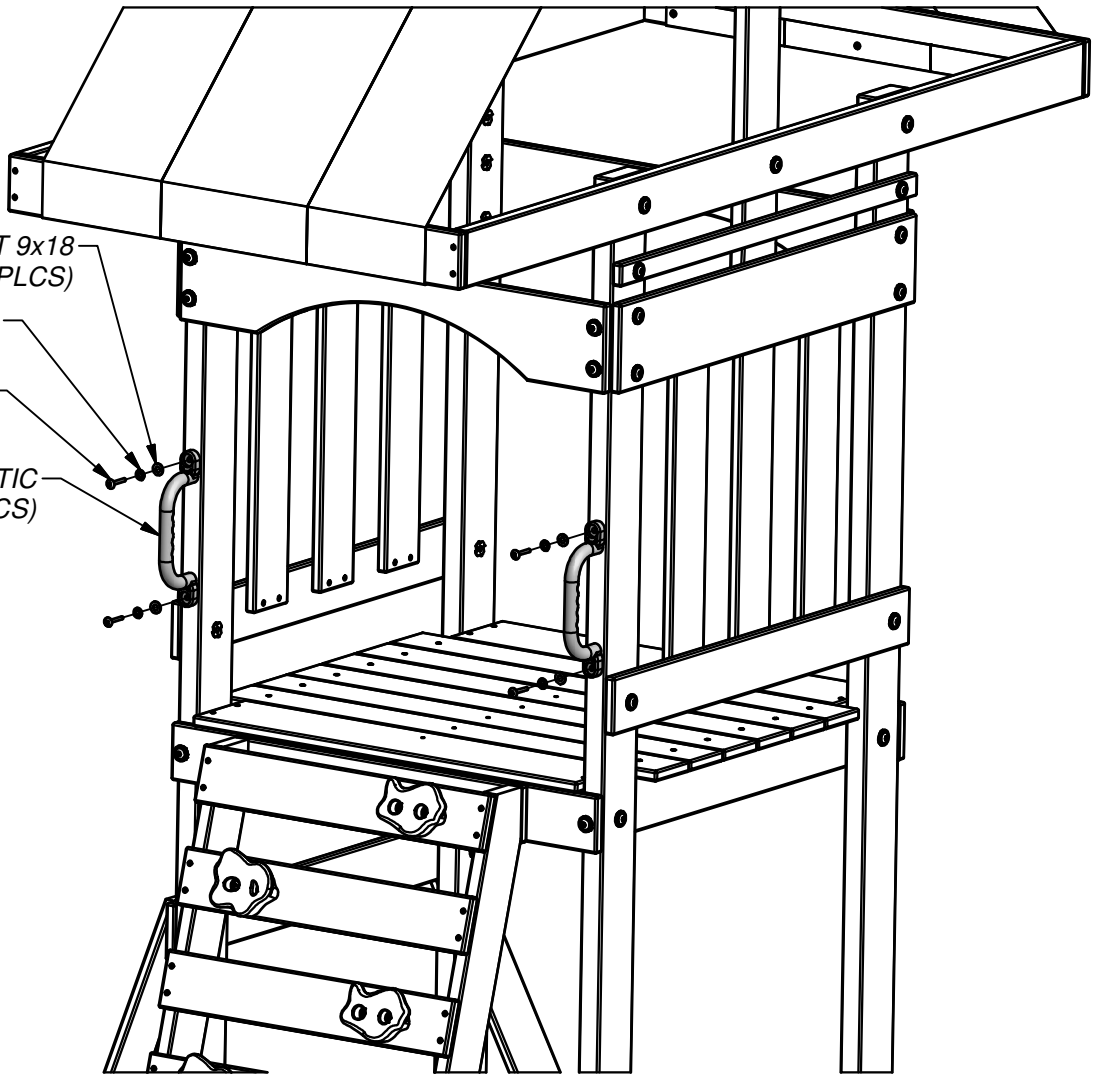
HAND GRIP YELLOW PLASTIC
(2 PLCS)



SWING BEAM ASSEMBLY



(1) HC - BYD ID TAG (LARGE) 2011 WITH AGES - A100164

STEP 24

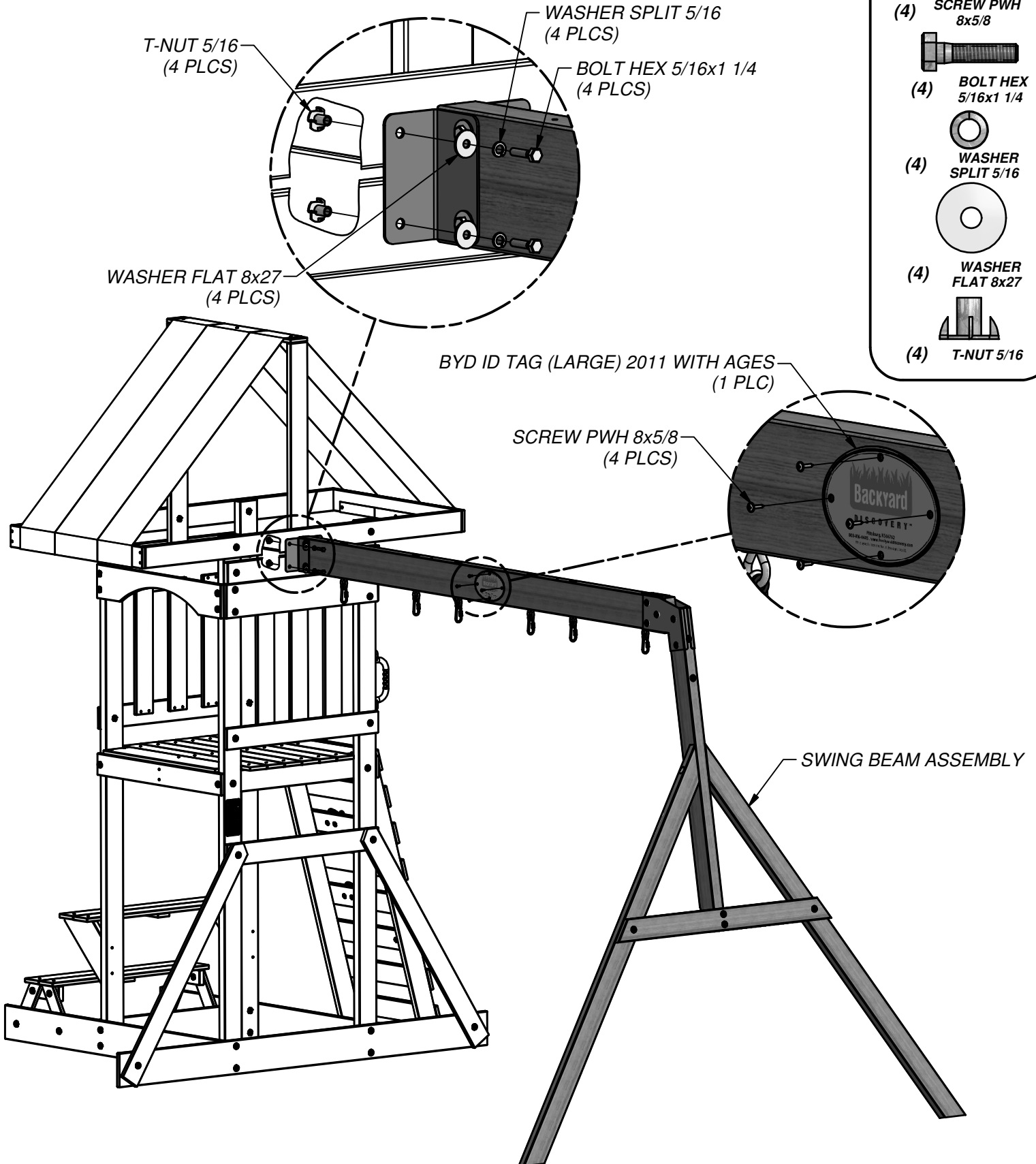

- (4) SCREW PWH 8x5/8
- (4) BOLT HEX 5/16x1 1/4
- (4) WASHER SPLIT 5/16
- (4) WASHER FLAT 8x27
- (4) T-NUT 5/16

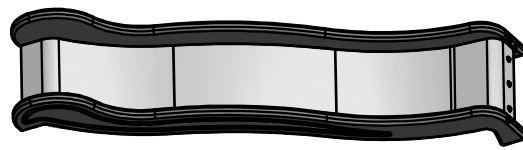

SLIDE ASSEMBLY

STEP 25

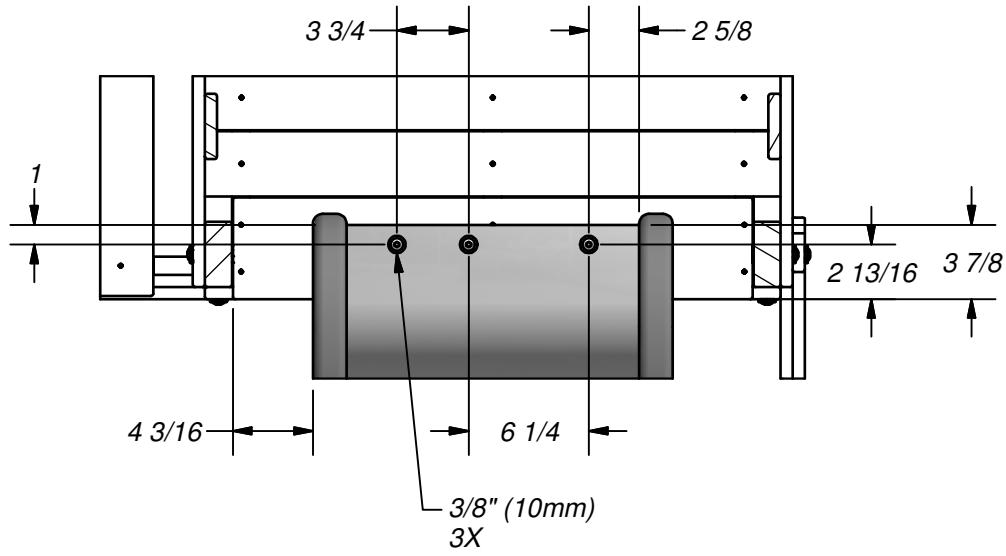

(3) BOLT WH 5/16x1/2

(3) T-NUT 5/16

BOLT WH 5/16x1/2
(3 PLCS)

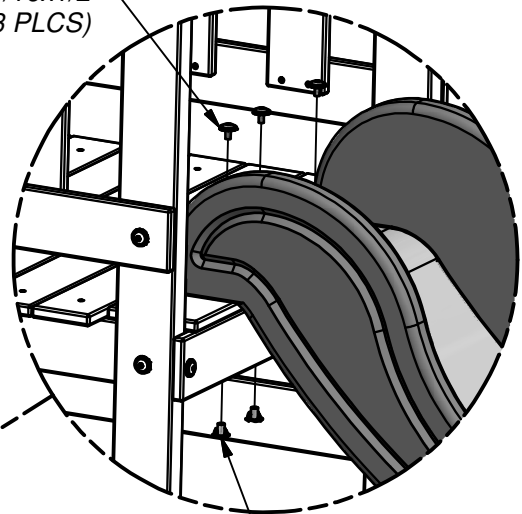

T-NUT 5/16
(3 PLCS)

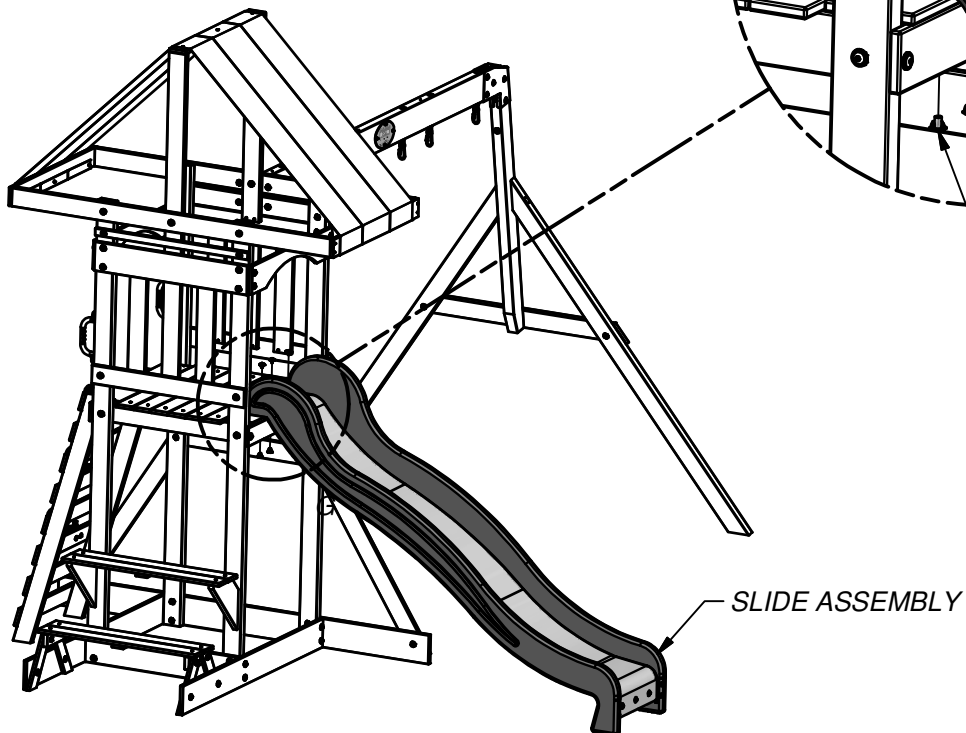

(2) UB - ROPE-CHAIN GREEN 33" - A100083

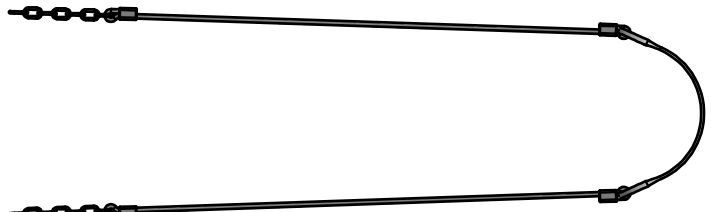

(2) - ROPE-CHAIN YELLOW 53.25" - A100121-1



(1) - TRAPEZE - A6P00034

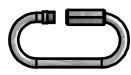

(2) FA - QUICK LINK - A100069

STEP 26

ROPE-CHAIN YELLOW 53.25"
(2 PLCS)

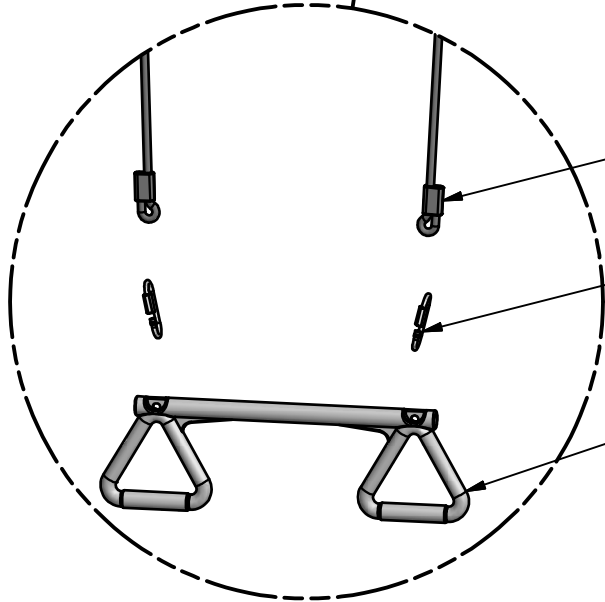
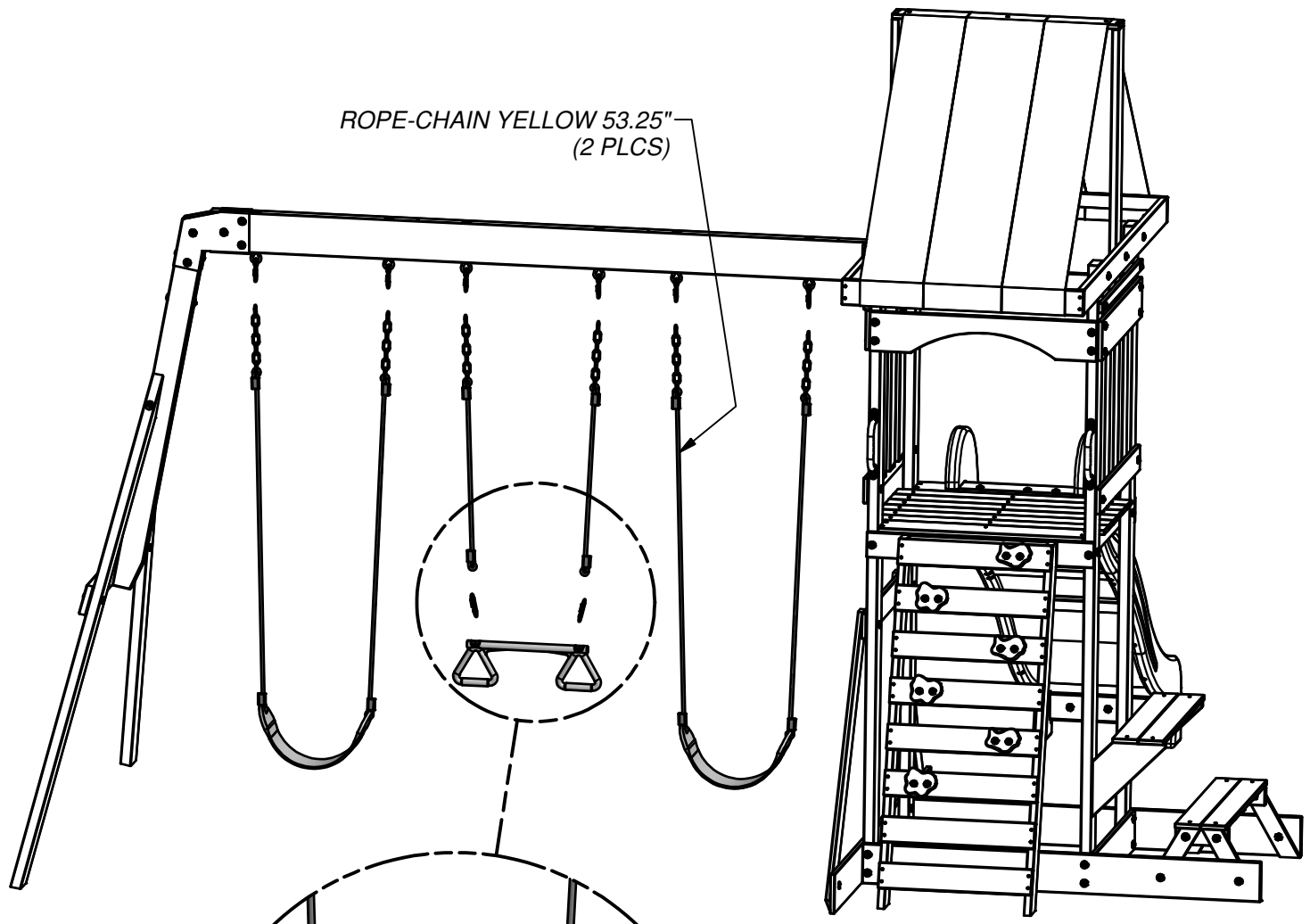

ROPE-CHAIN GREEN 33"
(2 PLCS)

QUICK LINK
(2 PLCS)

TRAPEZE
(1 PLC)

STEP 27

FAILURE TO USE STAKES CAN VOID WARRANTY & CAUSE INJURY!

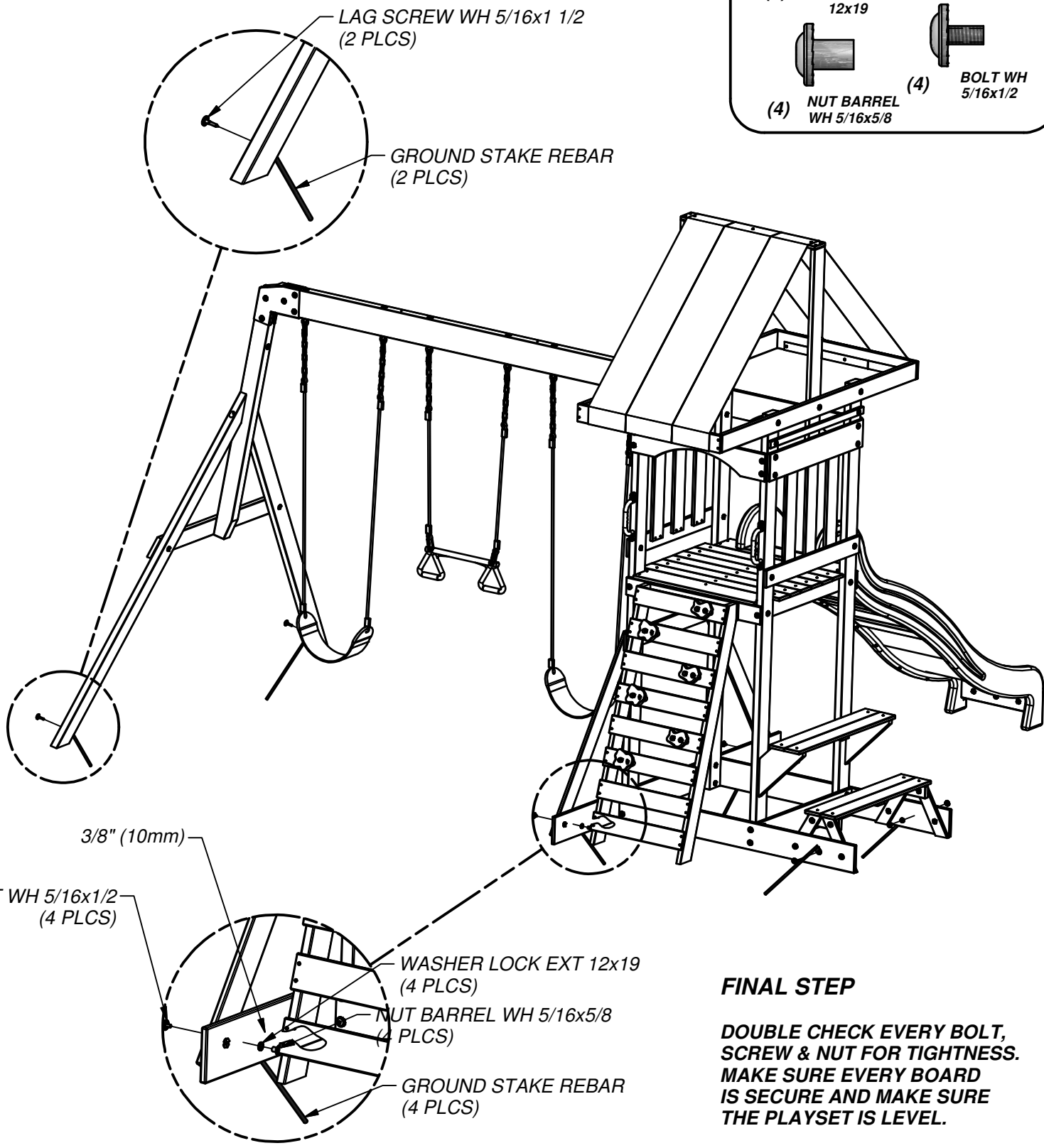
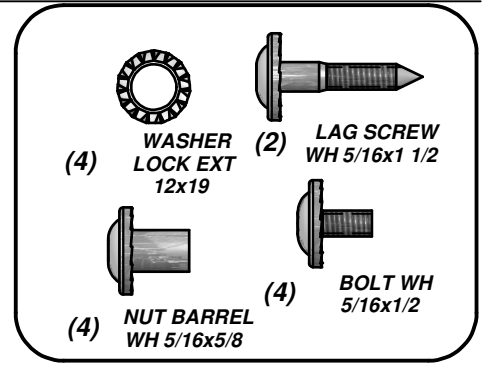

FINAL STEP

DOUBLE CHECK EVERY BOLT, SCREW & NUT FOR TIGHTNESS. MAKE SURE EVERY BOARD IS SECURE AND MAKE SURE THE PLAYSET IS LEVEL.

ENJOY YOUR NEW PLAYSET!

WARRANTY

AUSTRALIAN CONSUMER LAW

Many of our products come with a guarantee or warranty from the manufacturer. In addition, they come with guarantees that cannot be excluded under the Australian Consumer law. You are entitled to a replacement or refund for a major failure and compensation for any other reasonably foreseeable loss or damage.

You are entitled to have the goods repaired or replaced if the goods fail to be of acceptable quality and the failure does not amount to a major failure. Full details of your consumer rights may be found at www.consumerlaw.gov.au

Please visit our website to view our full warranty terms and conditions:

<http://www.lifespankids.com.au/Warranty-Policy-Kids>

Please send all warranty and support inquiries through our ticketing system via the email address:

support@lifespankids.com.au.