



## SPRINGFREE TRAMPOLINE OWNER'S MANUAL



Product may vary slightly from the item pictured due to model upgrades

Read all instructions carefully before using this product. Retain this owner's manual for future reference.

# TABLE OF CONTENTS

1.	TECHNICAL DATA	3
2.	GENERAL SAFETY INSTRUCTIONS	5
2.1	PURPOSE	5
2.2	DANGER FOR CHILDREN	5
2.3	RISK OF INJURIES	5
2.4	PRODUCT DAMAGE	6
2.5	ASSEMBLY ADVICE	6
3.	SAFETY INSTRUCTIONS FOR TRAMPOLINES	8
2.6	ACCIDENT CATEGORIES	12
2.7	METHODS OF ACCIDENT PREVENTION	14
4.	PARTS LIST AND ASSEMBLY INSTRUCTIONS	15
5.	SAFETY NET	18
5.1	ASSEMBLY AND INSTALLATION INSTRUCTIONS	20
5.1.1	PACKAGE CONTENTS	21
5.1.2	DIAGRAMS FOR PARTS	21
5.1.3	INSTRUCTIONS	22
5.2	SAFETY NET CARE AND MAINTENANCE INSTRUCTIONS	25
5.3	SAFETY NET USE INSTRUCTIONS	26
6.	IMPORTANT ADVICE FOR USAGE	28
7.	EXERCISE INSTRUCTIONS	30

8.	MAINTENANCE	32
9.	CLEANING	32
10.	DISPOSAL ADVICE	32
11.	WARRANTY REGISTRATION	33

# 1. TECHNICAL DATA

## Specifications of the product

Model	8'	10'	12'	13'	14'	16'
Size	Ø 244 cm	Ø 304 cm	Ø 366 cm	Ø 396 cm	Ø 426 cm	Ø 487 cm
Height	65 cm	70 cm	86 cm	86 cm	89 cm	96 cm
Jumping mat	199 cm	251 cm	316 cm	343 cm	373 cm	435 cm

Teile	Nr.	8'	10'	12'	13'	14'	16'
Frame cover	<b>A</b>	1	1	1	1	1	1
Jumping mat	<b>B</b>	1	1	1	1	1	1
Top rail	<b>C</b>	6	6	8	8	10	12
Metal Clips	<b>D</b>	44	56	73	78	84	96
Leg extension	<b>E&amp;F</b>	6	6	8	8	10	12
W-shaped leg	<b>G</b>	3	3	4	4	5	6
Screw	<b>H</b>	18	18	24	24	30	36
Tool	<b>I</b>	1	1	1	1	1	1

## 2. GENERAL SAFETY INSTRUCTIONS

### 2.1. PURPOSE

- The product is intended for home/domestic use only and is not suitable for professional or medical use.

### 2.2. DANGER FOR CHILDREN

- **WARNING! Trampolines over 51cm (20 inches) in height are not recommended for children under six years of age.**
- Children do not recognize potential dangers from this product. Keep children away from this product. It is not a toy. The product has to be stored out of reach of children and pets.
- Do not let children unsupervised near this product. Carry out the suitable settings in the product by yourself and supervise the activity.
- Be aware that the packaging material is not suitable for children. There is danger of suffocation!

### 2.3. RISK OF INJURIES

- Do not use the product if it is damaged or defective. In this case, please consult a qualified technician or our service center.
- Check the product before every use. Defective parts must be changed immediately as they can impair the function and the safety of the product.
- Make sure that no more than one person is using the product at the same time.
- Use the product only on even and non-slipping surfaces. Never use it near water and keep sufficient space around it to increase security.

- Beware of moving parts, which could catch your arms and legs. Do not stick any objects in the product's openings.

## 2.4. ATTENTION – PRODUCT DAMAGE



- Please do not alter the product. Only use original spare parts. Qualified technicians should only carry out repairs – improper repairs can lead to danger for the user. Use this product only as described in this manual.
- Protect the product against splashes, humidity, high temperature and direct sunlight.

## 2.5. ASSEMBLY ADVICE

- The assembly of the product must be done carefully and by **three** able-bodied adults. If in any doubt, ask a technically qualified person.
- Before you start with the assembly, read the instructions carefully and take a look at the assembly instructions.
- Remove all packaging materials and lay down all parts on a free space. This gives you an overview and simplifies the assembly procedure.
- Now, check with the parts list that no part is missing. Dispose of the packaging material when the assembly is completed.
- Beware that when using tools or doing technical work, there is always a risk of injuries. Therefore assemble the product carefully.
- Create a danger free environment; for example, do not let tools lay around the workspace. Store the packaging material in a way that cannot cause any danger. Foils and plastic bags are dangerous for children (danger of suffocation)!

- After installing product according to the instruction manual, please make sure that all screws, bolts and nuts are correctly installed and tightened and that all joints are tightly fixed.
- A free space of at least 9.5 m is necessary above the trampoline. An appropriate free space must be kept between the trampoline and possible sources of danger, such as electric cables, Tree branches, Playing devices, Swimming pools and fences,
- The Trampoline must be set up properly before use.
- Never set up the trampoline in heavy rain, wind or storm conditions, especially lightning conditions. It is recommended that the trampoline be taken apart and stored in bad weather.
- The metal frame of the trampoline will conduct electricity. Lightning, extension cords and all electrical equipment must never be allowed to come in contact with the trampoline.
- The Trampoline must always be used in a well-lit area.
- Nothing must be placed under the trampoline.
- The Trampoline in the vicinity of other leisure devices and constructions must not be used.
- When assembling or disassembly, please use gloves to protect your hands.

### 3. SAFETY INSTRUCTIONS FOR TRAMPOLINES

WARNING			
	<p>Do not land on the head or neck. There is the danger of paralysis or death, even if landing in the center of the trampoline.</p> <p>No somersaults tries should be attempted, in order to avoid danger of a head or neck landing.</p>		<p>One person only at a time may use the trampoline. Children under 6 years may use the trampoline only under special supervision. Several persons jumping at the same time on the trampoline will increase the danger of control loss, collision or falling down. It can lead to serious injuries</p>

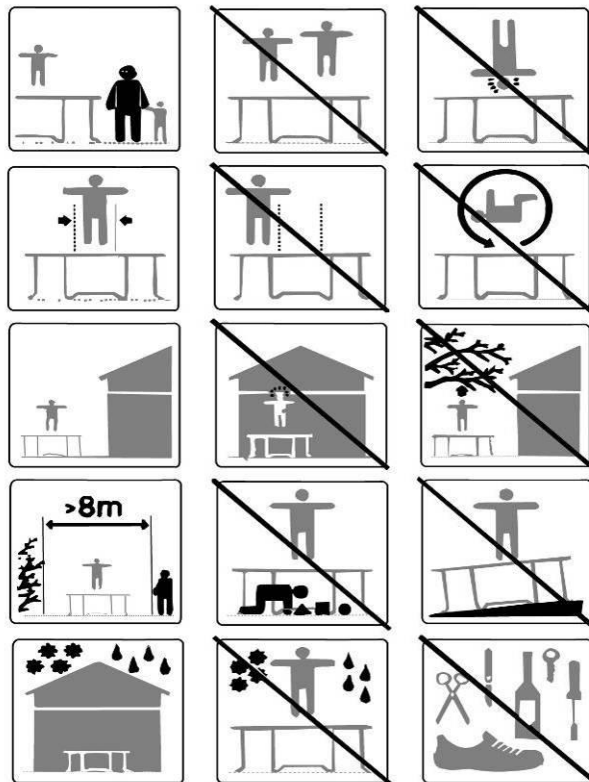



- Do not use the trampoline without supervision, regardless of age and experience.
- The safety instructions of the trampoline should always be considered and obeyed.  
During the use of the trampoline, there is a heavy danger of injury including permanent injuries such as paralysis, or even death.
- Even landings on the trampoline can lead to injuries, particularly to the back, neck or head. Somersaults must be avoided. In any case, only one person should use the Trampoline at a time.
- Neither the importer, the shops nor our manufacturers and suppliers will be responsible or liable in any form for direct, indirect or special damages caused during the use or in connection with it.
- This also applies to financial losses by theft, property loss, loss of earnings/services and profit, loss of satisfaction in the device, costs of the installation, disposal, damage by influences of the weather and environment as well as any other kinds of damages.
- Recognizable production defects are announced immediately by the dealer or manufacturer/ importer and shall be adjusted immediately for further use. The buyer/Operator of the trampoline has to examine the device regularly on wears or damage.
- No clothes with hooks or parts may be carried when jumping on the trampoline, in order to avoid hooks getting caught.
- The trampoline may be set up only on a flat ground.
- Strong winds can blow the Trampoline away. If strong winds are predicted, the Trampoline must be moved to a protected place, and taken apart, or fastened to the ground with cords and herrings. At least three anchorages are necessary. It is not enough to anchor the pennants in the ground since they can tear out of the patch cords.

- Try to avoid the moving the assembled trampoline, because it could bend during transportation. Should it be necessary to move the trampoline, please consider the following:
  - 1.) At least four people must be evenly spaced around the frame to lift the trampoline off the ground
  - 2.) The trampoline must be carried horizontally
  - 3.) Be careful while moving, because the frame could bend. If this happened, use four people to draw the trampoline in shape.
- Trampolines are jumping devices, enabling the user to jump into unusual heights as well as into a multiplicity of body movements. Jumping in the Trampoline, hitting the frame, cushioning or incorrect landing on the Trampoline can lead to injuries.
- All users must read the recommendations of the manufacturer themselves to ensure they use the device correctly.
- Users should be familiar with the assembly manual. This manual contains assembly guidance; selected precautionary measures as well as recommendations for servicing and maintenance of the trampoline, in order to ensure a secured and fun use of the Trampoline.
- It is the responsibility of the owner or the supervisor to guarantee that all users of the trampoline are informed sufficiently of all warning references and safety instructions.

## For the supervisor:

The supervisor's role is to make sure the users know all the safety rules as well as learn the basic, fundamental bounces. They need to enforce all the safety rules and warnings in the manual, frame and labels. When a supervisor is not available, the trampoline may be disassembled or covered to limit access. It is the supervisor's responsibility that the placard with the Trampoline Safety Tips is placed where all jumpers are informed about the tips.

- Implement all safety rules and make yourselves familiar with the information in the user manual.
- All users of the trampoline need a supervisor, regardless of the age and the experience of the user.
- Do not recommend this trampoline for children under 6 years of age.
- The trampoline can be only used, if the jumping mat is clean and dry. Worn or damaged jumping mats should immediately be replaced.
- Objects, which could be dangerous to the user, should be away from the trampoline
- Avoid unauthorized and unsupervised use of the trampoline.
- Do not use the Trampoline under influence of alcohol or drugs (incl. medicines).
- Learn the fundamental jump and body positions carefully, before trying difficult jumps.
- Stop jumping by bending your knees when your feet come to contact with the trampoline. The skill of braking should be used whenever you lose balance or control from a previous maneuver. Loss of balance or control will increase the risk of injury from landing on the frame, springs or completely off the trampoline. A controlled jump is considered landing on the same spot that you took off from .If you do lose control when you are jumping on the trampoline, bend your knees sharply when you land and this will allow you to regain control and stop your jump.

- Climb onto the trampoline. Do not jump on it directly. Do not use the trampoline as jumping board for other articles.

## 2.6. ACCIDENT CATEGORIES

Somersaults: A landing on the head or neck increases the risk of neck and back injuries, which can lead to paralysis and sometimes death. This can occur if the user makes an error and falls forward or backward. No somersaults should be attempted on the trampoline.

The probability of an injury increases if more than one person is jumping on trampoline. Users can collide, fall off the trampoline, land improperly on the jumping mat and on each other. Smaller users will more easily be hurt in this case.

Climbing on or off the trampoline: The trampoline's jumping mat is approximately one meter above the ground. Jumping off the trampoline onto the ground or another surface can lead to an injury. Jumping onto the trampoline from a building roof, a terrace or other objects can lead to injury. Small children need assistance when climbing on or off the trampoline. Be careful when climbing on and off the trampoline. Do not step on the cushioning or the framework. Do not use the framework for climbing on or off the trampoline.

Hitting the framework or the springs: When playing on the trampoline, stay in the center of the mat. This will reduce your risk of getting injured by landing on the frame of springs. Always keep the frame pad covering the frame of the trampoline. DO NOT jump or step onto the frame pad directly since it is not intended to support the weight of a person.

Loss of control: when users lose control of their jump, they can land wrongly on the jump mat, land on the framework or the cushioning or fall down from the Trampoline. A controlled jump is one where the jumper lands and jumps from the same spot. Before a more difficult jump maneuver is practiced, the basic controlled jump should be mastered perfectly and continuously. If a jump maneuver is attempted, which exceeds the abilities of the jumper; there is a danger of losing control. In order to regain control of the jump and land correctly, knees should be completely bent upon landing.

Under influence of drugs or alcohol: The probability of an injury rises if the user is under the influence of alcohol or drugs. These substances weaken the response, the faculty of judgment, the space awareness, the co-ordination and the motor functions of the user.

Collision with objects: while using the trampoline, person, animals or articles under it will increase the probability of an injury. Jumping on the trampoline while carrying an article, increases the probability of an injury. Placing the trampoline too close to electric wires, tree branches or other obstacles will increase the probability of an injury.

Bad maintenance of the Trampoline: Users can hurt themselves if the trampoline is in bad condition. A torn jumping mat, bent framework, missing cushioning or missing framework must be replaced before using the trampoline again. The trampoline should be examined before each use.

Weather conditions: A wet jumping mat is too slippery for safe jumping. Gusty or strong winds can lead to a loss of jump control when jumping. In order to lower the probability of an injury, the trampoline should be used under suitable weather conditions only.

## 2.7. METHODS OF ACCIDENT PREVENTION

### Role of the user in preventing accidents:

A basic knowledge of the trampoline by the user is a must for security. All users of the trampoline must learn first how to accomplish a low controlled jump as well as the fundamental landing positions and combinations, before turning to advance jump exercises. Users must know why they must control their jump, before they may practice other movements. A controlled jump is when you land and take off from the same location. The first lesson is the understanding of the correct order in developing jumping skills on a Trampoline. For further information or exercise materials, please turn to a trained Trampoline teacher.

### Role of the supervisor in preventing accidents:

It lies in the responsibility of the supervisors to guarantee a reasonable and experienced supervision of the users of trampoline. Rules and warnings in this manual must be applied, and known to the users of the trampoline in order to reduce the probability of accidents and injuries. In times, when the supervision is not possible or insufficient, the trampoline should be dismantled and stored in a secured place against unauthorized use.

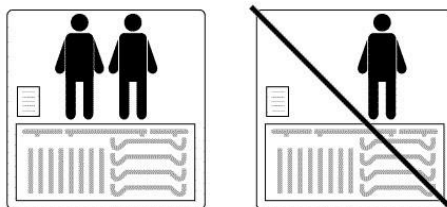

# 4. PARTS LIST AND ASSEMBLY INSTRUCTIONS

PARTS	ITEM	
Frame Cover		A
Jumping Mat		B
Top Rail		C
Metal Clips		D
Leg Extension		E
Leg Extension		F
W-Shaped Leg		G
Screw		H
Tools		I



**A** Frame Cover

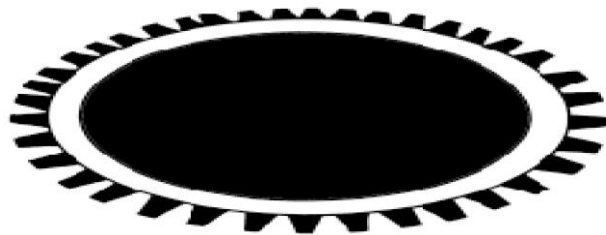

**B** Jumping Mat



**C** Top Rail



**D** Metal clips

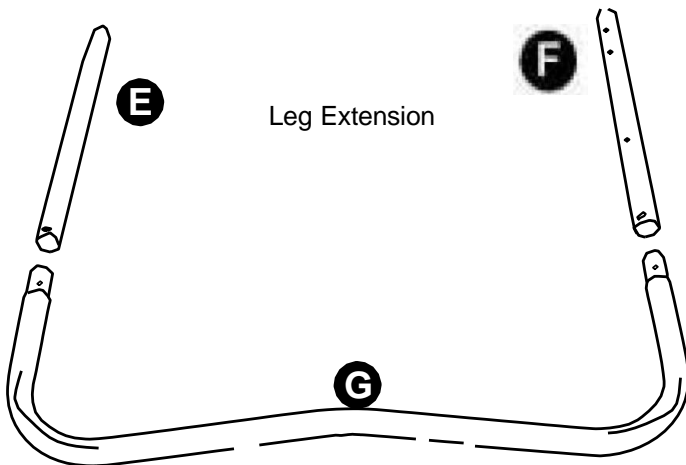

W-Shaped Leg Piece

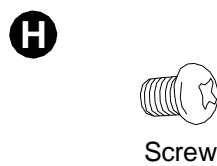

**H** Screw

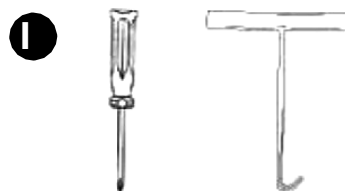

**I** Tools



# ASSEMBLY (Frame)

Refer to PARTS LIST for identification of parts.

**WARNING:** 3 adults in good physical condition are required for the following assembly. Wear proper shoes and maintain balance to prevent a fall. Failure to follow all instructions and warnings exactly may result in serious injury.



**1** Connect one top-rail with one rail-connector.



**2** Align the set-screws holes, insert small set-screw & tighten.

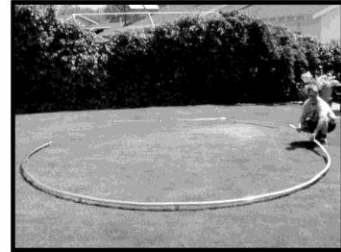

**3** Continue alternating top-rails with rail-connectors.

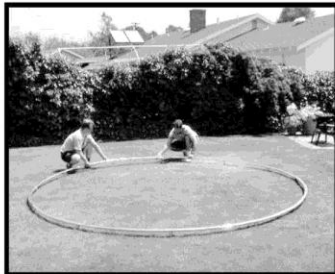

**4** Secure each connection with a small set screw.



**5** Bring both sides of the circle firmly together and secure with small set-screw. A 3rd person may be required to hold the other end down.

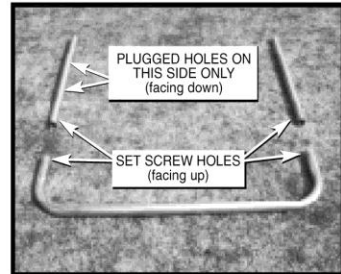

**6** Lay one U-shaped leg piece, one leg extension, and one plugged leg extension on the ground.  
*(Plugged holes are for optional Safety Enclosure.)*



**7** Connect both extensions to U-shaped piece as shown. Align the set-screws holes, insert large set-screws & tighten.



**8** Turn U-leg so plugged holes are on right side. Attach the U-leg assembly to the top-rail as shown. The U-legs should now connect 2 top rails & a rail connector.

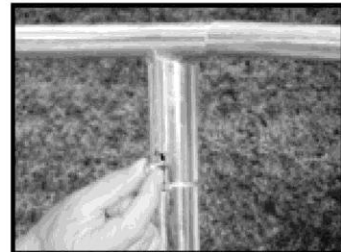

**9** Secure U-leg to top-rail with large set-screws on each side.



**10** Repeat procedure for each U-leg and attach to top-rail with large set-screws.

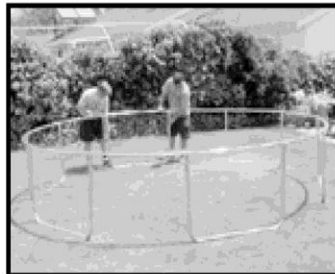

**11** Continue until all U-legs are in place.

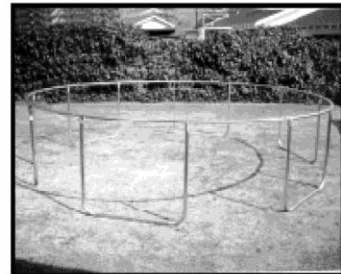

**12** Make sure all set-screws are tight. Frame is now complete.



## (SAFETY PAD & WEATHER COVER)

**DANGER:** 3 adults are required to use strap tools in exact manner as illustrated in STEP 17. Straps will create high levels of tension when assembled. Please use extreme caution not to pinch your fingers.



**13** Layout mat on ground and attach first clip into strap.



**14** Attach strap with clip to the frame. (WARNING) The trampoline is under heavy tension & a great deal of effort may be required to attach bands to frame. Be careful not to pinch fingers or slip. Serious injury may occur!



**15** Go directly across from where you attached first strap, and attach the second strap.

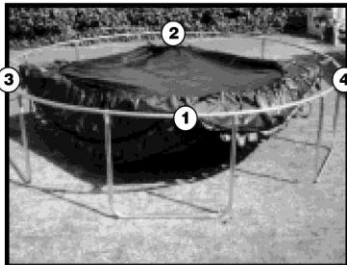

**16** Attach two more sides directly across from each other.



**17** Use strap tools as shown for the following procedures. (3 people may be needed).

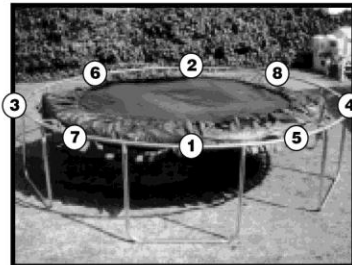

**18** Follow sequence above. It's important to consistently attach the opposite end of the previous straps to even out tension.



**19** Lay blue frame cover on outer edge so springs are covered—just like a shower cap.



**20** Tie all black straps to top rail of frame. Do not tie to springs.



**21** That's it! Your trampoline is complete!

To disassemble repeat steps 1-21 in reverse.

## 5. SAFETY NET

### Liability

While every attempt is made to embody the highest degree of protection in all equipment, we cannot guarantee freedom from injury. The user assumes all risk of injury due to use. All merchandise is sold on this condition, which no representative of the company can waive or change.

### WARNING:

In addition to the instructions and precautions provided with your trampoline, the following precautions must be observed while using the Trampoline Safety Enclosure.

- The metal frame of the trampoline enclosure will conduct electricity. Lights, extension cords, and all such electrical equipment must never be allowed to come in contact with the enclosure.
- Inspect the enclosure before each use. Make sure the straps and all parts are correctly and securely positioned and attached. Tighten any loose hardware. Replace any worn, defective, or missing parts.
- Wear comfortable clothing free of hooks, snaps, drawstrings for anything which may snag or catch in the safety enclosure mesh, Remove jewelry, necklaces, and earrings.
- Climb on and off the trampoline only through the safety enclosure entrance and securely close entrance. Users, especially children, must not attempt to enter or exit between the trampoline frame and the enclosure. Doing this may pose a strangulation risk.

## WARNING:

- Do not touch or rebound off the safety enclosure mesh while using the trampoline.
- Read all instructions and complete all assembly before using the safety enclosure.
- Use trampoline and trampoline enclosure only with mature, knowledgeable supervision.

**For Recreational Use ONLY.**

**Not for Professional Use.**

**Weight Limit for Trampoline User is 100kgs (220lb).**

## 5.1. ASSEMBLY AND INSTALLATION INSTRUCTIONS

- Adequate overhead clearance is essential. A minimum of 24 ft (7.3m) from ground level is recommended. Provide clearance for wires, tree limbs, and other possible hazards.
- Lateral clearance is essential. Place the trampoline and trampoline enclosure away from walls, structures, fences, and other play areas. Maintain a clear space on all sides of the trampoline and trampoline enclosure. A minimum of six feet from frame edge is recommended.
- The trampoline is heavy and is under heavy tension. Three able-bodied adults are required to set it up. Use appropriate clothing and shoes. Failure to follow these instructions may lead to injury or damage to the trampoline.
- Never set-up the trampoline in heavy rain, wind or storm conditions, especially lightning storms. It is recommended that the trampoline be taken apart and stored in bad weather.
- When moving the assembled trampoline, have at least four people evenly spaced around the frame (NSEW) to lift the trampoline off the ground.
- Place the trampoline and trampoline enclosure on a level surface before use.
- Use the trampoline and trampoline enclosure in a well-lit area. Artificial illumination may be required for indoor or shady areas.
- Secure the trampoline and trampoline enclosure against unauthorized and unsupervised use.
- Remove any obstructions from beneath the trampoline and trampoline enclosure.
- The owner and supervisors of the trampoline and trampoline enclosure are responsible to make all users aware of practices specified in the “Use Instructions”.
- The trampoline enclosure is only to be used as an enclosure for a trampoline and the trampoline must be of the appropriate size covered by the specific enclosure.

### 5.1.1. ASSEMBLY AND INSTALLATION INSTRUCTIONS

FIG.	PARTS NAME	10'/12'/13'/14'/15'/16' (6 Legs)	10'/12'/13'/14'/15' (5 Legs)	10'/11'/12'/ 13'/14' (4 Legs)	6'/8'/10' (3 Legs)
1	GALVANIZED PIPE	12 or 6 PCS	10PCS	8PCS	6PCS
2	GALVANIZED PIPE	12 or 6 PCS	10PCS	8PCS	6PCS
3	STEEL JIG	24 or 12 PCS	20PCS	16PCS	12PCS
4	SCREW SET	48 or 24 PCS	40PCS	32PCS	24PCS
5	SAFETY MESH	1PC	1PC	1PC	1CS
6	SPACER	24 or 12 PCS	20PCS	16PCS	12PCS
7	Tools	1PC	1PC	1PC	1CS

### 5.1.2. DIAGRAMS FOR PARTS

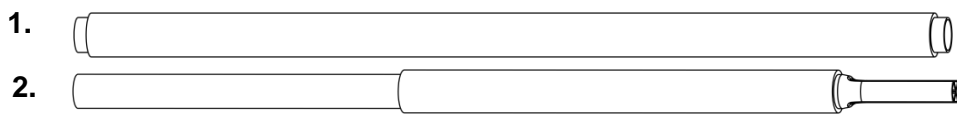

OTHERS: -

**3. STEEL JIG**



**5. SAFETY Mesh**

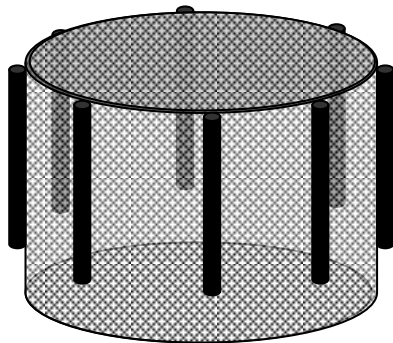

**4. SCREW SET**



**6. SPACER**



**Tools**

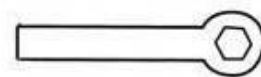

**WARNING:** ONLY TO BE ASSEMBLED BY AN ADULT. READ AND FOLLOW THESE INSTRUCTIONS PRIOR TO ASSEMBLY AND USE OF EQUIPMENT.

### 5.1.3. INSTRUCTIONS

#### STEP 1:

SPREAD THE SAFETY MESH OUT FLAT ON THE TRAMPOLINE MAT FIRSTLY AS SHOWN IN FIGURE 1, AND PUT TWO SECTIONS OF SUPPORT PIPES CONNECTED TOGETHER AS SHOWN IN FIGURE 2.

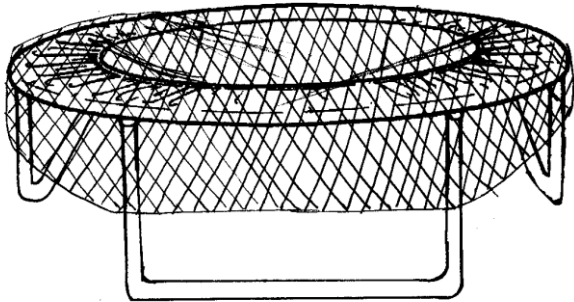

FIGURE 1

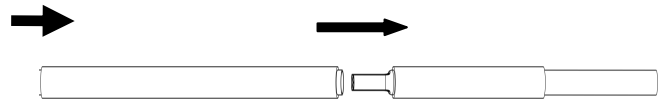

FIGURE 2

---

#### STEP 2:

INSERT SUPPORT PIPES INTO THE SLEEVES OF SAFETY MESH IN ORDER, AS SHOWN IN FIGURE 3.

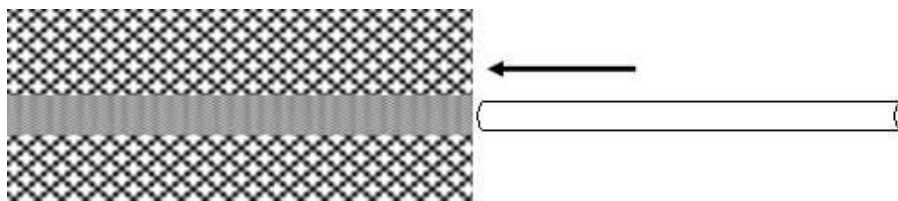
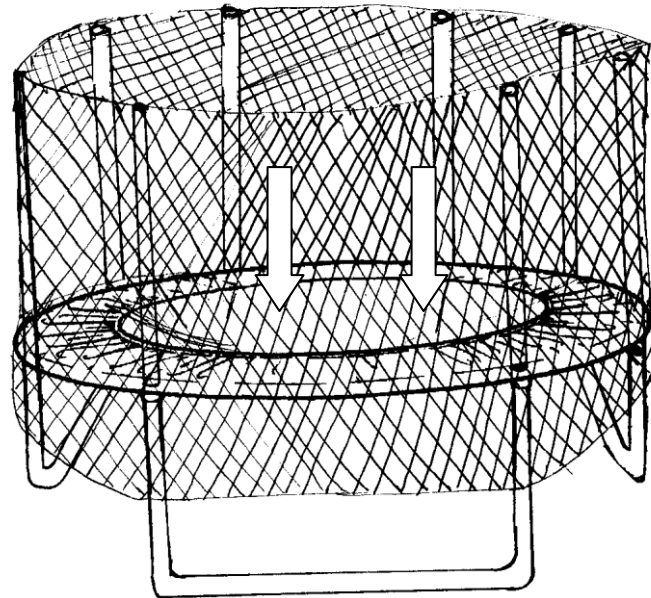

FIGURE 3

**STEP 3:**

STAND THE SUPPORT PIPES CORRESPOND ANEAR TO EACH TRAMPOLINE LEG ORDERLY (AS SHOWN IN FIGURE 4)

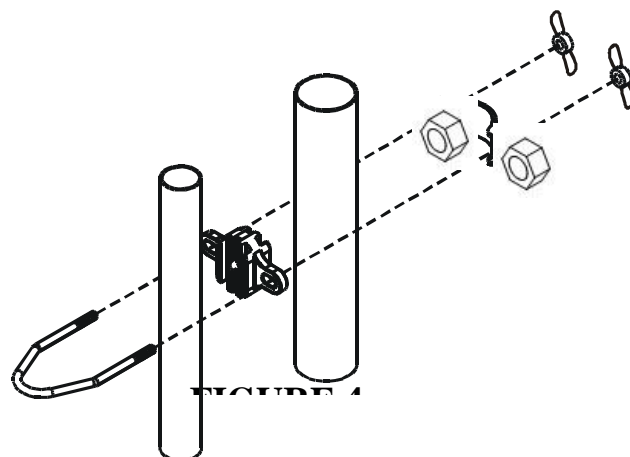

**FIGURE 4**

---

**STEP 4:**

FIXING SUPPORT PIPES ONTO TRAMPOLINE LEGS WITH TWO SPECIAL JIGS, TWO SPACER AND FIRM THEM USE SCREW SET (2 JIGS FOR A STAND PIPE), AS SHOWN IN FIGURE 5.



**FIGURE 5**



**STEP 5:**

HOOK THE STEEL JIG USING THE PLASTIC HOOK SEWN ON THE SAFETY NET TO SECURE THE SAFETY EQUIPMENT, AS SHOWN IN FIGURE 6.



**FIGURE 6**

---

**STEP 6:**

USE THE HOOK TO ATTACH THE TRIANGLERINGS ON THE TRAMPOLIN MAT TO THE FRAME AS SHOWN IN FIGURE 7.



**FIGURE 7**

Congratulations, your trampoline and enclosure is now complete!



## 5.2. SAFETY NET CARE AND MAINTENANCE INSTRUCTIONS

Inspect the trampoline and trampoline enclosure before each use and replace any worn, defective, or missing parts.

The following conditions could represent potential hazards:

1. Missing, improperly positioned, or insecurely attached frame padding, barrier or enclosure support system (frame) padding and pole caps.
2. Punctures, frays, tears, or holes worn in the bed or frame padding, barrier or enclosure support system (frame) padding and pole caps.
3. Deterioration in the stitching or fabric of the bed or frame padding, barrier or enclosure support system (frame) padding and pole caps.
4. Ruptured springs or bands.
5. A bent or broken frame or support system.
6. A sagging barrier or bed.
7. Sharp protrusions on the support (frame) or suspension system.
8. Loosened or missing hardware.

### 5.3. SAFETY NET USE INSTRUCTIONS

- Do not allow more than one person on the trampoline or inside the trampoline enclosure. Use by more than one person at the same time can result in serious injuries.
- Use trampoline and trampoline enclosure only with mature, knowledgeable supervision.
- Trampolines over 20 inches (51cm) tall are not recommended for use by children under six years of age.
- Never set-up the trampoline in heavy rain, wind or storm conditions, especially lightning storms. It is recommended that the trampoline be taken apart and stored in bad weather.
- When moving the assembled trampoline and trampoline enclosure have at least four people evenly spaced around the frame (NSEW) to lift the trampoline off the ground.
- Inspect that trampoline and trampoline enclosure before each use. Make sure that frame cover, barrier and, enclosure support padding are correctly and securely positioned. Replace any worn, defective, or missing parts.
- The metal frame of the trampoline will conduct electricity. Lights, extension cords, and all such electrical equipment must never be allowed to come in contact with the trampoline.
- Wear comfortable clothing. Remove jewelry, necklaces, and earrings. Wear clothing free of draw strings, hooks, loops or anything that could get caught in the barrier.
- Enter and exit the enclosure only at the enclosure door or barrier opening designated for that purpose. It is a dangerous practice to jump from the trampoline to the ground or floor when dismounting, or to jump onto the trampoline when mounting. Do not use trampoline as a springboard to other objects.
- Avoid bouncing too high. Stay low until bounce control and repeated landing in the center of the trampoline can be accomplished. Control is more important than height.
- Properly secure the trampoline when not in use. Protect it against unauthorized use. If a trampoline ladder is used, the supervisor should remove it from the trampoline when

leaving the area to prevent unsupervised access by children under six years of age.

- For additional information concerning the trampoline equipment, contact the manufacturer.
- Read all instructions before using the trampoline and trampoline enclosure. Warnings and instructions for the care, maintenance, and use of this trampoline and trampoline enclosure are included to promote safe, enjoyable use of this equipment.
- Do not intentionally bounce off the barrier.
- Do not attempt to jump over barrier or attempt to crawl under barrier.
- Do not hang from, kick, cut or climb on barrier.
- Do not attach anything to the barrier that is not manufacturer approved accessory or part of the enclosure system.

## 6. IMPORTANT ADVICE FOR USAGE

The jumper must first learn all of the basic, fundamental bounces before attempting more difficult ones. Low, controlled bounces are a good start before learning the basic landing positions and combinations. Jumpers need to understand that control is the key to a successful jump. Review of the users' manual to learn basic technique is a must. Following the tips in the placard is also important. Contact a certified trampoline instructor for more information.

- In the learning phase, users must practice and perfect these basic techniques. The deceleration or examining of the jump must be informed first and emphasized as a security measure. Users must break their jump, as soon as they begin to lose the balance or lose control of their jump. Bending the knees on landing so as to absorb the energy of the jump does this. Thus users can stop the jump immediately and avoid control loss.
- A better, more controlled jump for the trampoline is one in which the user lands on the original jumping place. This exercise is learned only if users can repeat it regularly. Users may never turn to a more difficult exercise before having mastered all the previously learned exercises.
- Users should have a respectively short jumping time. Jumping for too long exposes the user to an increased danger of injury. Longer jumping periods also reduce the interest of the other users, as they have to wait for their turn to jump.
- The clothes must consist of a t-Shirt, short trousers, Gymnastic shoes and thick socks (can also be barefoot). Beginners should wear appropriate protective clothing, like long arm shirts and training trousers, until they can control the landings correctly. Thus,

scratches are prevented by wrong landing on the elbows and knees. No firm shoes may be carried, since they lead to strong wear of the Trampoline.

- For correct climbing on and off the trampoline, a firm rule must be followed by beginning users: They should always use their hand on the framework and use this to climb up or down, then stand on the jumping mat. When the ascending and descending off the trampoline does not rise directly on the framework or seize the framework. To descend, users have to go to the exterior of the jump mat, bend forwards and put their hands on the framework, then step from the mat to the ground. DO NOT dismount by jumping off the trampoline and landing on the ground, regardless of the makeup of the ground. If small children are playing on the trampoline, they may need help in mounting and dismounting.
- Daring jumps are not recommended. All skills should be learned with normal jumps. The control of the jump and not the height are to be emphasized. User may not jump alone and unsupervised on the Trampoline.

## 7. EXERCISE INSTRUCTIONS

### FUNDAMENTAL BOUNCES

#### STANDING BOUNCE



1. Start in the center of bed, feet shoulder-width apart, arms at side, eyes on end of bed.
2. As you jump from trampoline, arms come up and forward, circling outward and back To side as you again contact bed. Bring feet together, toes pointed, in the air, feet Shoulders-width apart again as you contact bed. Arms need never go above your shoulders or behind your body.

#### KNEE BOUNCE



1. First, assume kneeling position in center of bed, **back straight**, eyes on end of bed.
2. Pump your way to your feet by bouncing, using your arms as in standing bounce.
3. Duplicate position from a low bounce

#### HANDS & KNEE DROP



1. First, assume position shown in illustration, keeping head up, eyes on end of bed.
2. Duplicate position from a low bounce. Keep your hands as close to your knees as shown in illustration.

#### FRONT DROP



1. First, assume position of hands and knees bounce. Begin to bounce slightly in this position, then kick legs back, land on stomach, taking some weight on bent fore-arms as shown in illustration. Make sure you **kick backwards, do not go forward**, and return to hands and knees position.
2. Try from a low bounce, **kicking backwards**, making your belt land where your feet were.

#### SEAT DROP



1. First, assume sitting position in center of bed, legs spread wide, and hands on bed, leaning slightly forward.
2. Duplicate this position from a low bounce. To come to your feet again, be sure to lean forward and press bed with your hands.

## BACK DROP



1. Lie on your back on bed, spread your legs slightly and raise them about 45 degrees from the surface of the bed, raise your arms to corresponding angle, raise head and look at end of trampoline. This is your landing position.
2. Try cautiously from a low bounce, making sure you do not lose sight of end bar of trampoline at any time. Weight should be taken more on your shoulders than on your hips.

## PIROUETTE



### HALF PIROUETTE:

Done like a standing bounce, but at **top of bounce**, swiftly turn head and search for opposite end of trampoline. Do not travel. Land on feet.

### FULL PIROUETTE:

Done as above, but continue around, until a complete circle has been made. Spot by looking for end bars as you complete trick.

## TUCK POSITION



Done like a standing bounce, but at **top of bounce**, bring knees to chest and grasp with arms. Then lower feet to contact bed.

## PIKE POSITION



Done like a standing bounce, but at **top of bounce**, keeping knees locked and toes pointed, raise legs as illustrated, then lower feet to contact bed.

## LAYOUT POSITION



Done like a standing bounce, but at **top of bounce**, stretch slightly, arching back, and momentarily looking skyward.

## STRADDLE POSITION



Done like pike bounce, but with legs spread as widely as is comfortable. Reach for your toes!

## 8. MAINTENANCE

Assess the product regularly for damages or abrasion, and let authorized dealers handle it. If damages occur before the warranty expiry date, please ensure that you have retained your proof of purchase.

## 9. CLEANING

Do not use any abrasive cleansers for the cleaning. Use a soft, damp cloth to eliminate dirt and dust.

## 10. DISPOSAL ADVICE

### **Packaging:**

This product is delivered with a packaging, to protect it from damages during transport. The packaging materials are made of raw materials, which are recyclable. Please dispose of these materials according to material type.

If you want to dispose of the products, dispose according to regulations in your area. Refer to your municipal institution for further information.



## 11. WARRANTY REGISTRATION

Please visit the following link to complete the product warranty form online. Please visit:

<http://www.warrantyform.lifespanfitness.com.au>

**PLEASE NOTE:** YOUR WARRANTY IS ONLY VALID IF YOU CAN PROVE YOU ARE THE ORIGINAL PURCHASER OF THIS ITEM (i.e. a copy of the receipt, invoice, delivery date or internet confirmation)