

## I. SAFETY AND MAINTENANCE INSTRUCTION

### 1. Assembling the Chair:

- Carefully follow the provided assembly instructions.
- Ensure all bolts, screws, and components are securely tightened.
- Regularly inspect the chair for loose or damaged parts.

### 2. Weight Limit:

- Adhere to the specified weight limit indicated by the manufacturer.
- Do not exceed the recommended weight capacity to avoid structural damage.

### 3. Proper Sitting Position:

- Sit squarely in the centre of the chair with your back against the backrest.
- Adjust the chair height so that your feet rest flat on the floor, promoting proper posture.

### 4. Adjustments:

- Utilize the chair adjustments (height, tilt, and armrests) to suit your comfort and ergonomic needs.
- Do not force adjustments; if they are difficult, consult the user manual for guidance.

### 5. Regular Inspections:

- Periodically inspect the chair for any signs of wear, loose screws, or damaged components.
- Tighten any loose screws promptly, and replace any damaged parts.

### 6. Avoid Rough Handling:

- Do not lean back too forcefully or use excessive force when adjusting the chair.
- Avoid dropping into the chair, as this can cause unnecessary strain on the structure.

### 7. Floor Surface:

- Place the chair on a stable and level surface.
- Use a chair mat on carpeted floors to prevent wear, and ensure the wheels move smoothly.

### 8. Cleaning and Maintenance:

- Clean the chair regularly with a mild detergent and a soft cloth.
- Do not use abrasive cleaners that may damage the chair's finish.
- Lubricate moving parts, such as wheel casters, as recommended by the manufacturer.

### 9. Avoid Overloading:

- Do not use the chair as a step stool or place heavy objects on it, as this may compromise its structural integrity.

## II. WARRANTY

### AUSTRALIAN CONSUMER LAW

Many of our products come with a guarantee or warranty from the manufacturer. In addition, they come with guarantees that cannot be excluded under the Australian Consumer Law. You are entitled to a replacement or refund for a major failure and compensation for any other reasonably foreseeable loss or damage.

You are entitled to have the goods repaired or replaced if the goods fail to be of acceptable quality and the failure does not amount to a major failure. Full details of your consumer rights may be found at [www.consumerlaw.gov.au](http://www.consumerlaw.gov.au).

Please visit our website to view our full warranty terms and conditions: <http://www.lifespanfitness.com.au/warranty-repairs>

### WARRANTY AND SUPPORT

Any claim against this warranty must be made through your original place of purchase. Proof of purchase is required before a warranty claim may be processed.

If you have purchased this product from the Official Lifespan Fitness website, please visit <https://lifespanfitness.com.au/warranty-form>

For support outside of warranty, if you wish to purchase replacement parts or request a repair or service, please visit <https://lifespanfitness.com.au/warranty-form> and fill in our Repair/Service Request Form or Parts Purchase Form.

Scan this QR code with your device to go to [lifespanfitness.com.au/warranty-form](https://lifespanfitness.com.au/warranty-form)



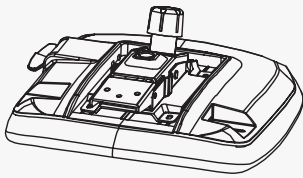

A - Seat 1pc.

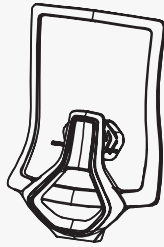

B - Back 1pc.



C - Armrest 1set

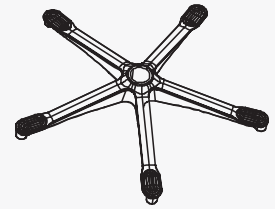

D - Base 1pc

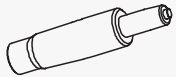

E - Gas Lift 1pc.

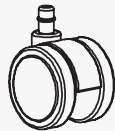

F - Castors 5pcs.

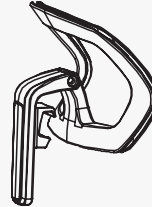

G - Headrest 1pc



1 - Screw 8X20 3pcs



2 - Screw 8X25 4pcs

1

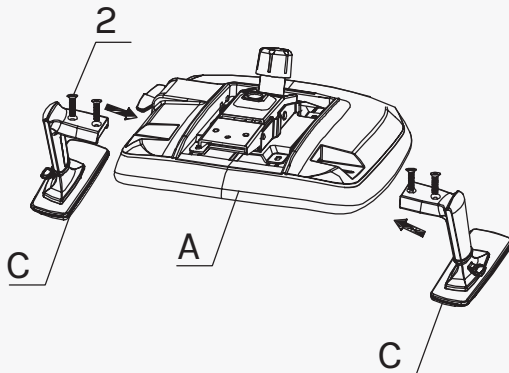

2

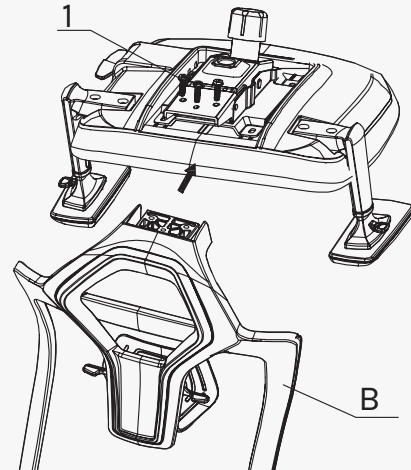

3

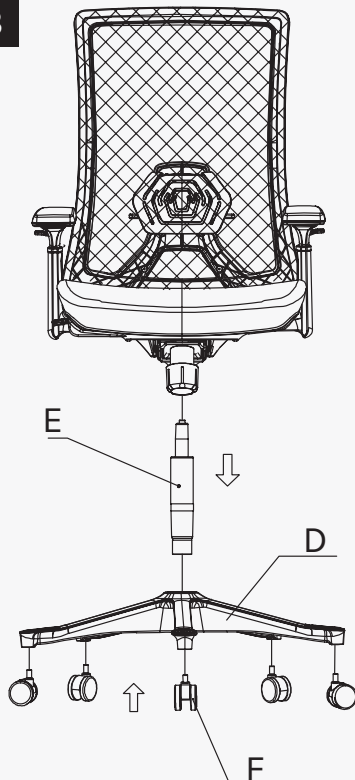

4

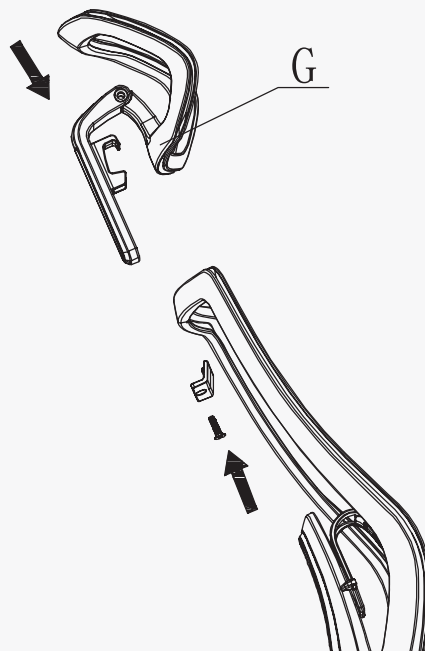

5

