

# USER MANUAL

## Yardtopia Maryborough 3x3m Timber & Steel Roof Gazebo Set

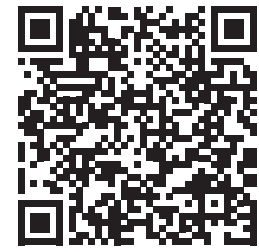

Find the Digital  
Manual Online

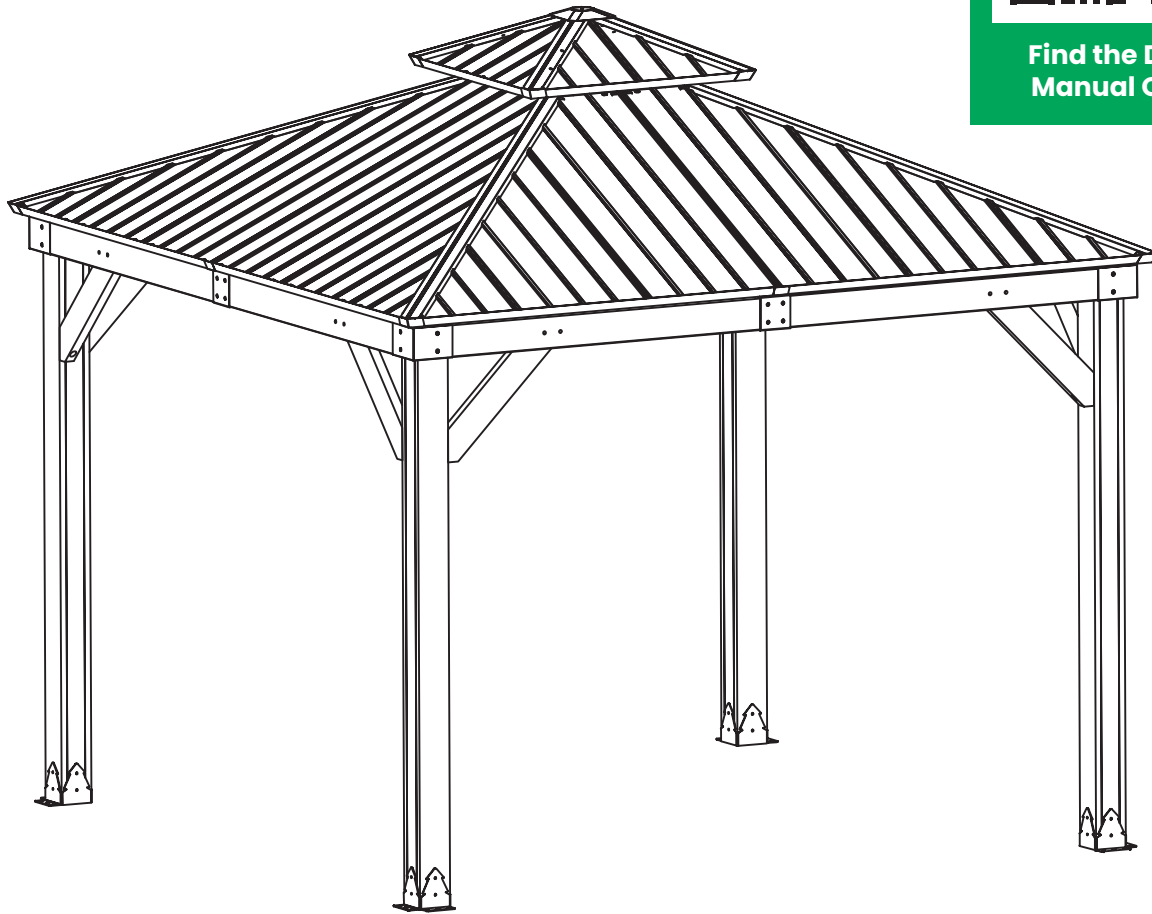

\*YT000 & YT001 & YT002 & YT003 3x3m Yardtopia Maryborough Timber & Steel Roof Gazebo



**WARNING:** The disassembled product may contain small parts which pose a choking hazard to children under 3.

### IMPORTANT:

This product may contain sharp points and small parts prior to assembly. The owner's manual contains safety, assembly, use and maintenance instructions. This product must be assembled by an adult who has read and understood these instructions. Keep the packaging away from children and dispose of all packaging before use.

*For the installer and your children's safety, it is important to fully read and understand the instructions and safety hazards before commencing the assembly of the product.*

### NOTE:

This manual should not be used to guide your purchasing decision. Your product, and the contents inside its carton, may vary from what is listed in this manual. This manual may also be subject to updates or changes. Updated manuals are available through our website at [www.lifespankids.com.au](http://www.lifespankids.com.au).

---

# TABLE OF CONTENTS

<b>I. SAFETY WARNINGS AND MAINTENANCE INSTRUCTIONS</b>	3
<b>II. PREPARATION</b>	4
<b>III. SET UP DIMENSIONS</b>	5
<b>IV. PARTS LIST</b>	6
<b>V. ASSEMBLY INSTRUCTIONS</b>	9
<b>VI. WOOD ADVICE</b>	46
<b>VII. CLEANING</b>	48
<b>VIII. WARRANTY</b>	48

---

# I. SAFETY WARNINGS AND MAINTENANCE INSTRUCTIONS

IT IS IMPORTANT TO CHECK AND TIGHTEN ALL HARDWARE AT THE BEGINNING AND DURING THE SEASON AS THEY MAY LOOSEN DUE TO WOOD EXPANSION AND CONTRACTION.

**Important:** Owners are responsible for maintaining the legibility of warning labels. Retain this manual for future reference on maintenance instructions.

- **Do not climb or walk on the roof** for any reason.
- **Assembly requires two or more people** to ensure safety.
- Before digging or driving stakes into the ground, **check for underground utilities**.
- **Check and tighten all hardware regularly**, especially at the start and during the season, as wood may expand and contract over time.
- Carefully check for overhead lines, ensuring there is at least **6 feet (2 meters) of clearance from electrical wires**.
- **Building permits** may be required for permanent structures. As the purchaser or installer, consult local planning, zoning, and building inspection departments to confirm compliance with applicable building codes and zoning regulations.
- **Wood is not fire-retardant** and will burn. Grills, fire pits, and chimineas pose a fire hazard if placed too close to the structure.
- **Wear gloves** during installation to prevent injury.
- Follow all safety warnings provided with your tools, and **wear safety glasses** during installation.
- Check and tighten all nuts and bolts **twice a month during the usage season**. Be careful not to overtighten to avoid damaging the wood. Pay special attention at the beginning of each season.
- **Oil all metallic moving parts** monthly during the usage season.
- Inspect all bolt coverings and sharp edges **twice a month** to ensure they are securely in place and replace them if necessary—especially at the start of each season.
- Surface rust or rust can occur when protective coatings are scratched or in high salt or moisture content areas. To minimize this condition, if any scratch surfaces appear, immediately touch up with rust inhibiting paint.
- For rusted areas on metallic parts like hinges or brackets, **sand and repaint using non-lead-based paint**. Do not leave any surface rust unattended as the oxidation can worsen and will make it difficult to remove the rust later on.
- **Inspect wood parts monthly**. In dry seasons, wood grain may lift, creating splinters. Lightly sand any rough areas to maintain a safe environment. After sanding, apply a protective sealant to prevent severe weather damage, checking, or splitting.
- The unit is stained with a waterborne translucent finish for colour only. To protect the wood, you must apply a sealant **once or twice a year**, depending on your climate. Before applying, lightly sand any rough spots. This maintenance is required to keep your warranty valid.
- Do not use any abrasive cleansers for the **cleaning**. Use a soft, damp cloth to eliminate dirt and dust.

---

## II. PREPARATION

### Placement of Product

It is critically important to start with square and level footings, a concrete pad, or a ground when attaching your structure.

- Pay close attention to the items required for each step. Ensure you are using the correct hardware for each step, as using incorrect hardware may result in improper assembly.
- Always double-check for underground utilities and overhead electrical lines before proceeding.
- Check the concrete surface is not damaged and structurally compliant. The thickness of the concrete base is required to be around 100mm.

### Owner's Manual: Basic Setup Dimensions & Assembly Notes

Post mounts are provided with your structure to allow for permanent installation on a pre-existing concrete surface.

- Hardware to attach the post mounts to the structure is included.
- Hardware to mount the structure permanently to a concrete surface is **not** included and must be purchased separately.
- Hardware to mount the structure permanently to a wood deck is **not** included. Ensure there is sufficient structural support under the deck before attaching the structure permanently.

### Metal Roof Assembly

- Place roofing materials on a non-abrasive, flat surface both before and after assembly to avoid bending, denting, or scratching.

### Before you start:

1. Please read all instructions carefully.
2. Separate and count all parts and hardware.
3. Ensure weather conditions are good for the whole day as this may take a few hours for installation.
4. Keep all small parts away from children and pets as they can pose a choking hazard.

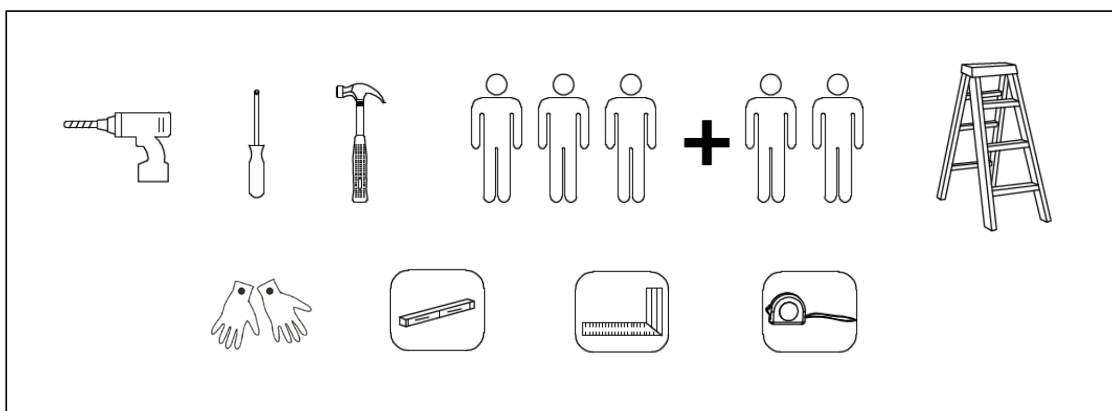

---

### III. SET UP DIMENSIONS

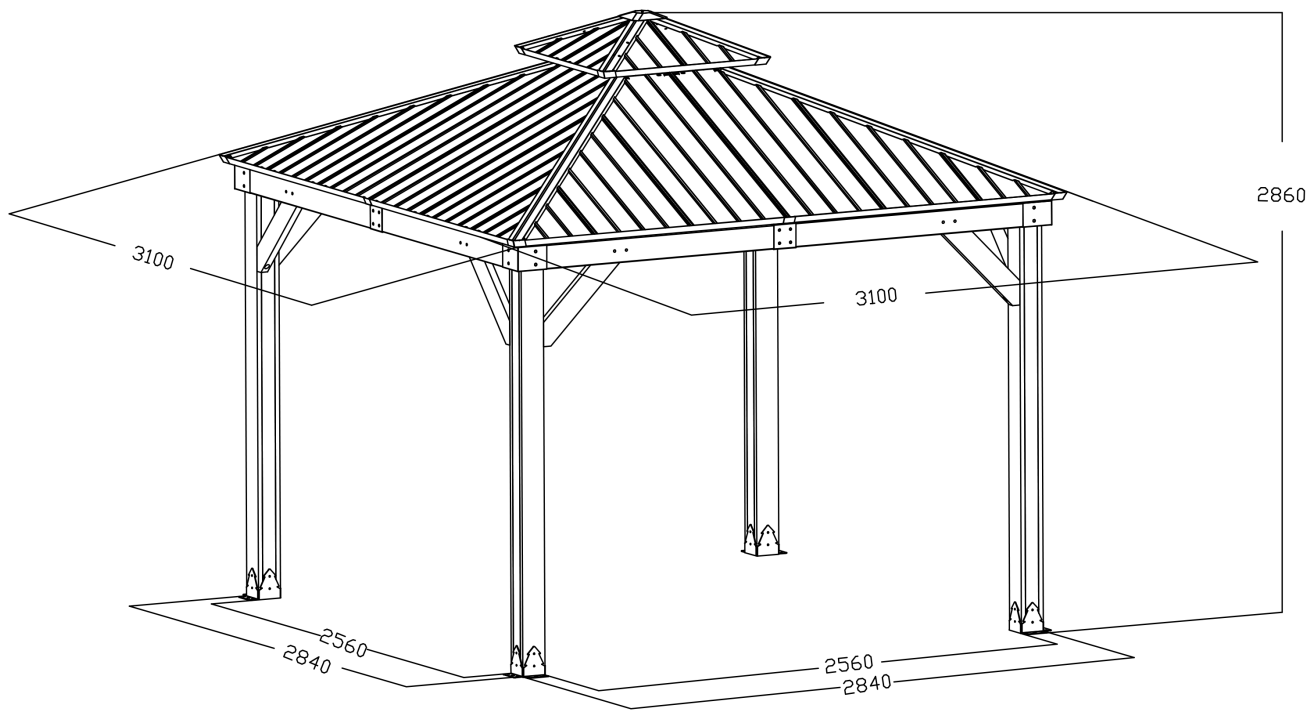

## IV. PARTS LIST

01  
4pcs

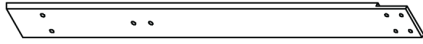

02  
4pcs

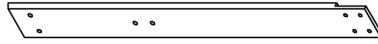

05  
8pcs



06  
4pcs

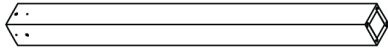

M2  
4pcs

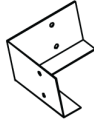

Z4  
4pcs



X1  
8pcs



X5  
4pcs



Q2  
1pc



PP  
8pcs

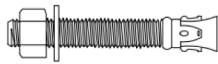

N1  
4pcs

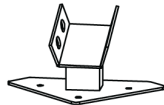

Z3  
4pcs



X2  
8pcs



X4  
8pcs



Q1  
4pcs



A1 4pcs



E4 4pcs



B1 4pcs

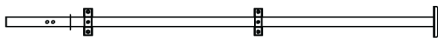

F1 4pcs



D1 2pcs



H2 4pcs



D2 2pcs



H6 4pcs



E3 4pcs



I5 4pcs

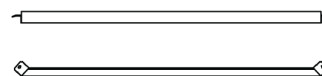

**K1 4pcs**



**S1 4pcs**



**K2 4pcs**



**S2 4pcs**



**K3 4pcs**



**L1 1pc**



**L2 1pc**



**K4 4pcs**



**T1 4pcs**

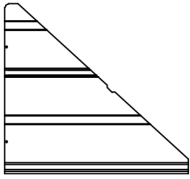

**T7 4pcs**

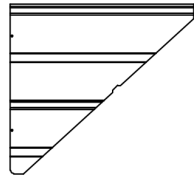

**T12 4pcs**

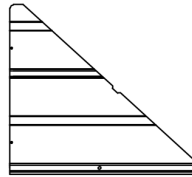

**T13 4pcs**

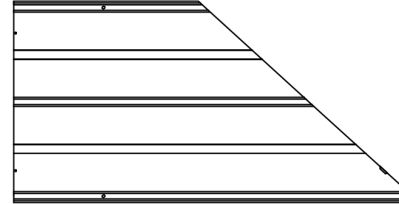

**T14 4pcs**

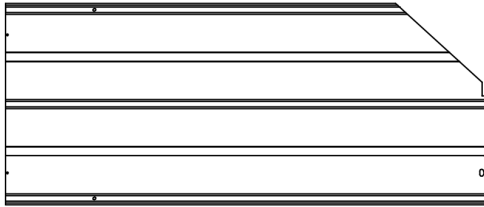

**T16 4pcs**

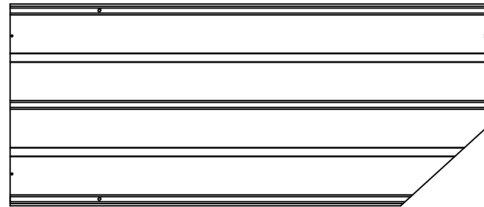



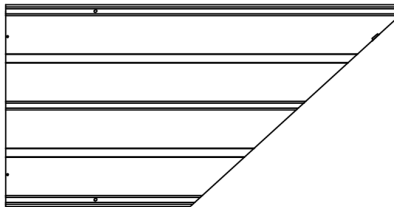



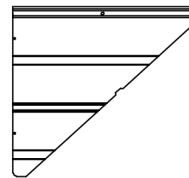

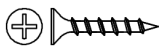

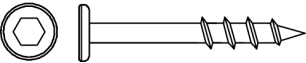
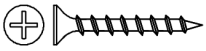

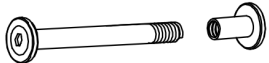



**T17 4pcs**

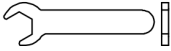
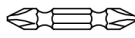
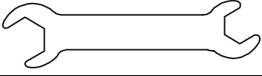
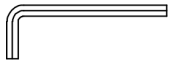

**T18 4pcs**

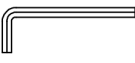

AA	8pcs	M8X165	
BB	32+ 3pcs	M5X30	
CC	8pcs	M10*80	
DD	8pcs	M6*70	
EE	12+ 2pcs	M5*40	
FF	16+ 1pc	M8*25	
GG	13+ 1pc	M6	
HH	16pcs	M8X60	
JJ	16+ 1pc	M5X20	
KK	12+ 1pc	M6X55	
LL	16+ 1pc	M6X45	
MM	20+ 1pc		
NN	4+ 1pc	M6X25	
TT	112+ 8pcs	M6X15	
UU	16pcs	6X200	
Y1	1pc	M6	
Y2	1pc	M6	
Y3	2pcs	M10	
Y4	2pcs	M8	
Y5	2pcs	M8	
Y6	2pcs	M6	
Y7	1pc	M6	
Y8	1pc	M8	



## V. ASSEMBLY INSTRUCTIONS

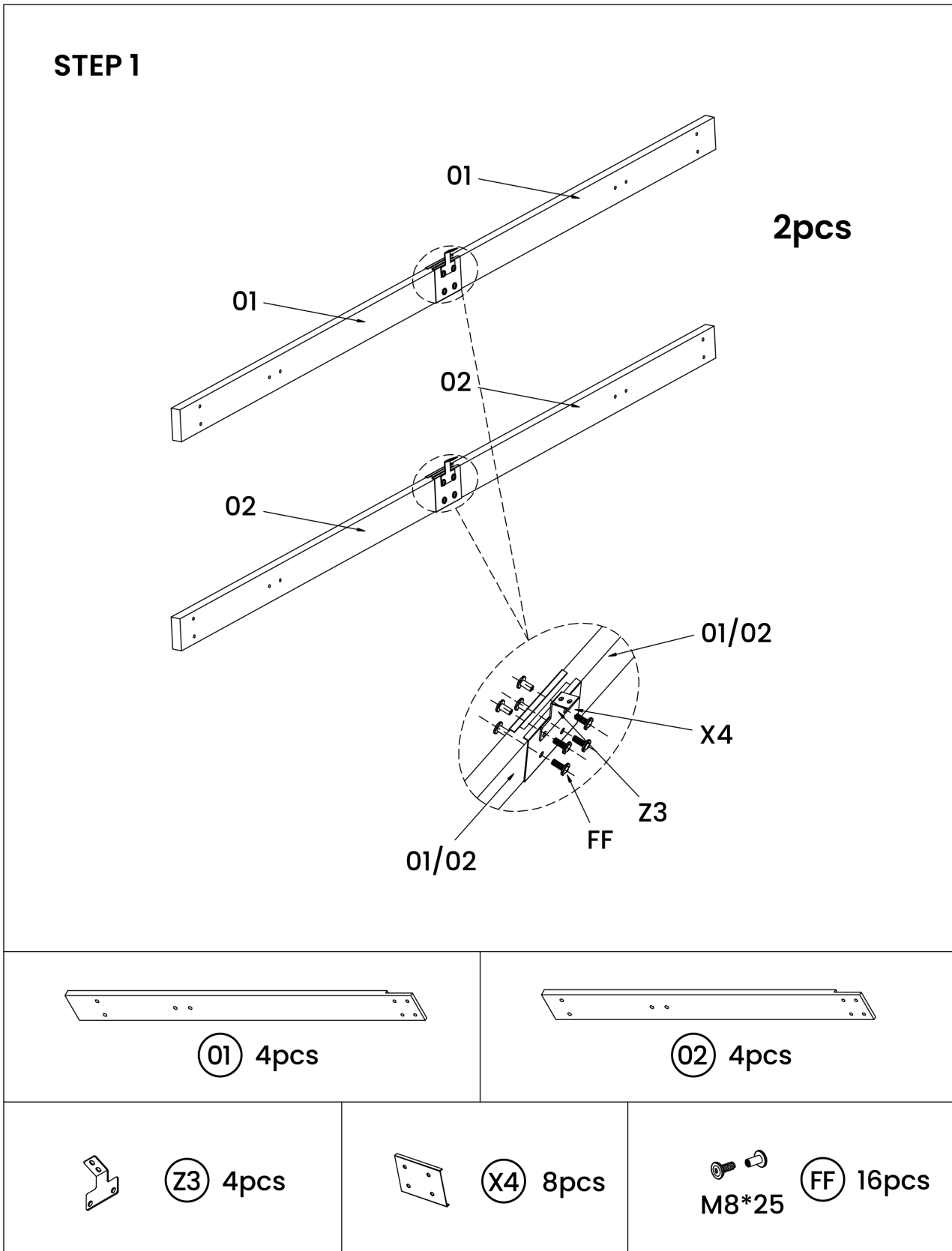

## STEP 2

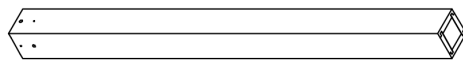
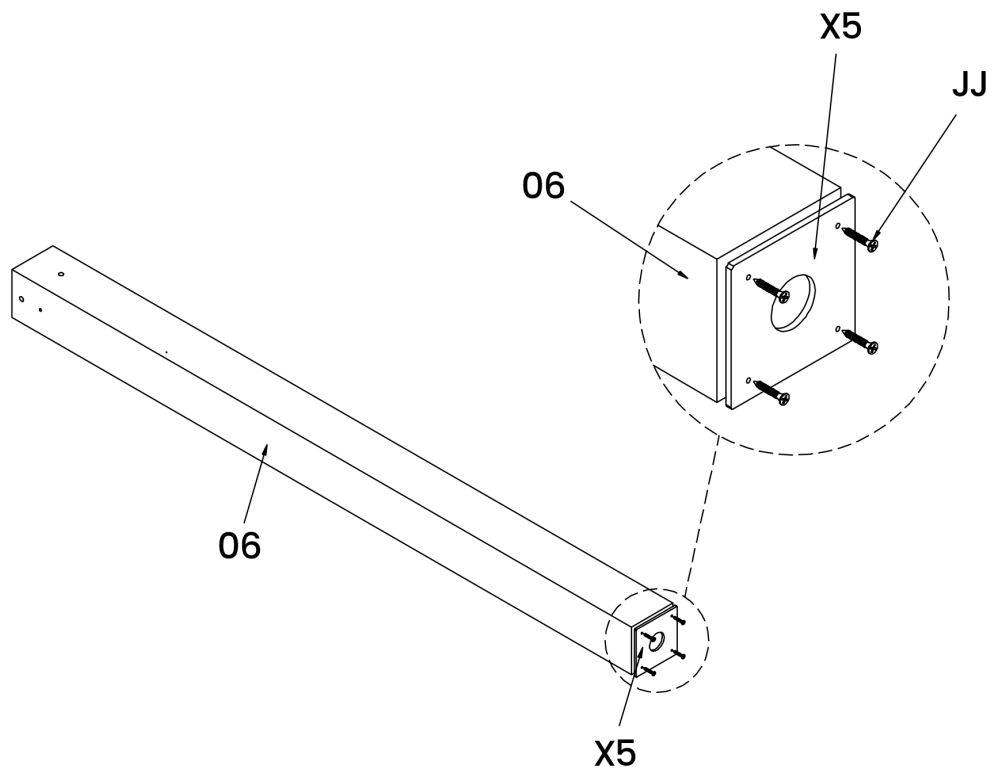

① 06 4pcs

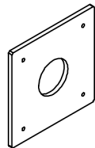

① X5 4pcs



① JJ 16pcs  
M5X20

### STEP 3

Note: The direction of the middle tab (Z3) must face inwards, see step 5.

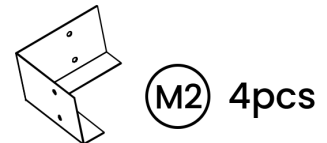
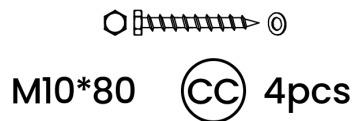
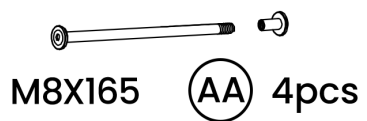
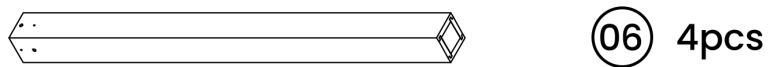
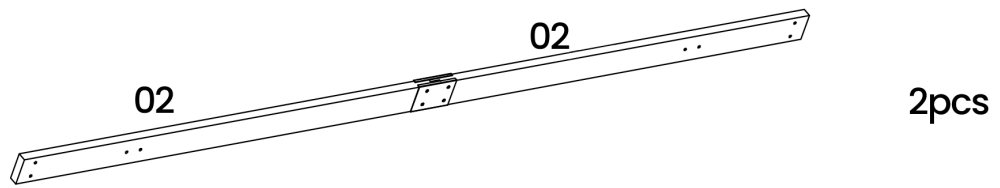
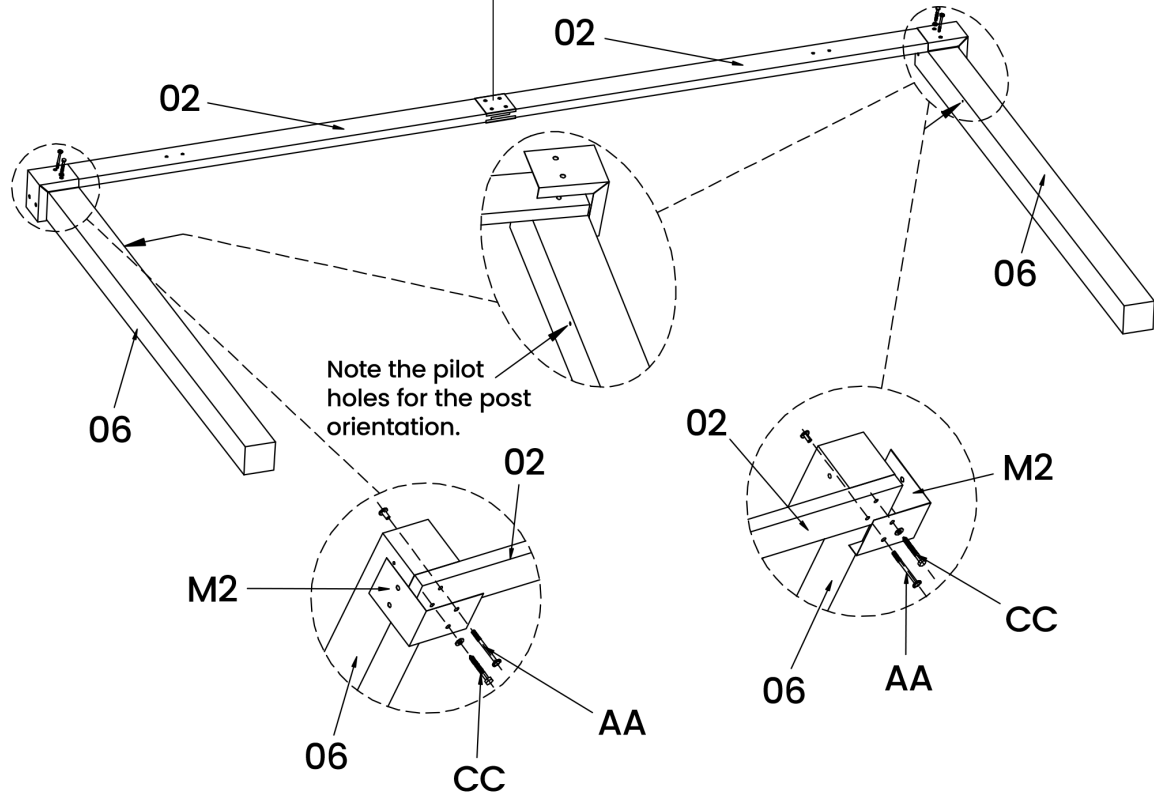

# STEP 4

2pcs

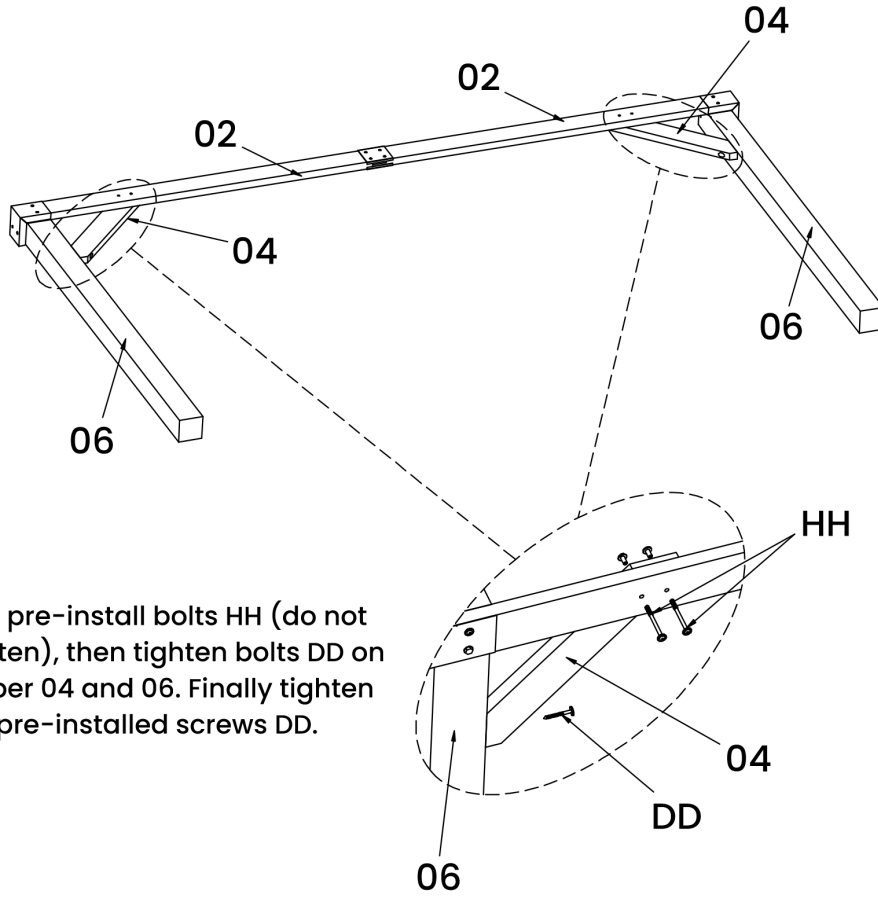

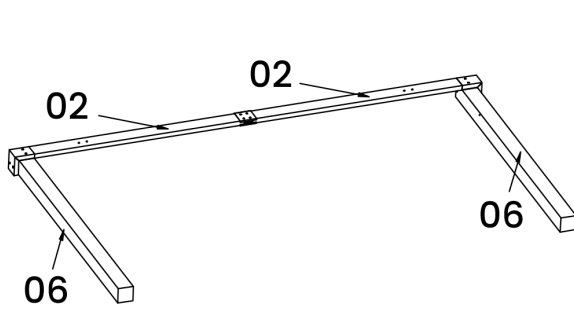

First pre-install bolts HH (do not tighten), then tighten bolts DD on timber 04 and 06. Finally tighten the pre-installed screws DD.

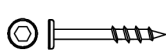

2pcs

 (04) 4pcs

 M6\*70 (DD) 4pcs

 M8X60 (HH) 8pcs

## STEP 5

Slot the part 01 into the brackets on part 02. Note the direction of the middle tabs (Z3) must face inwards.

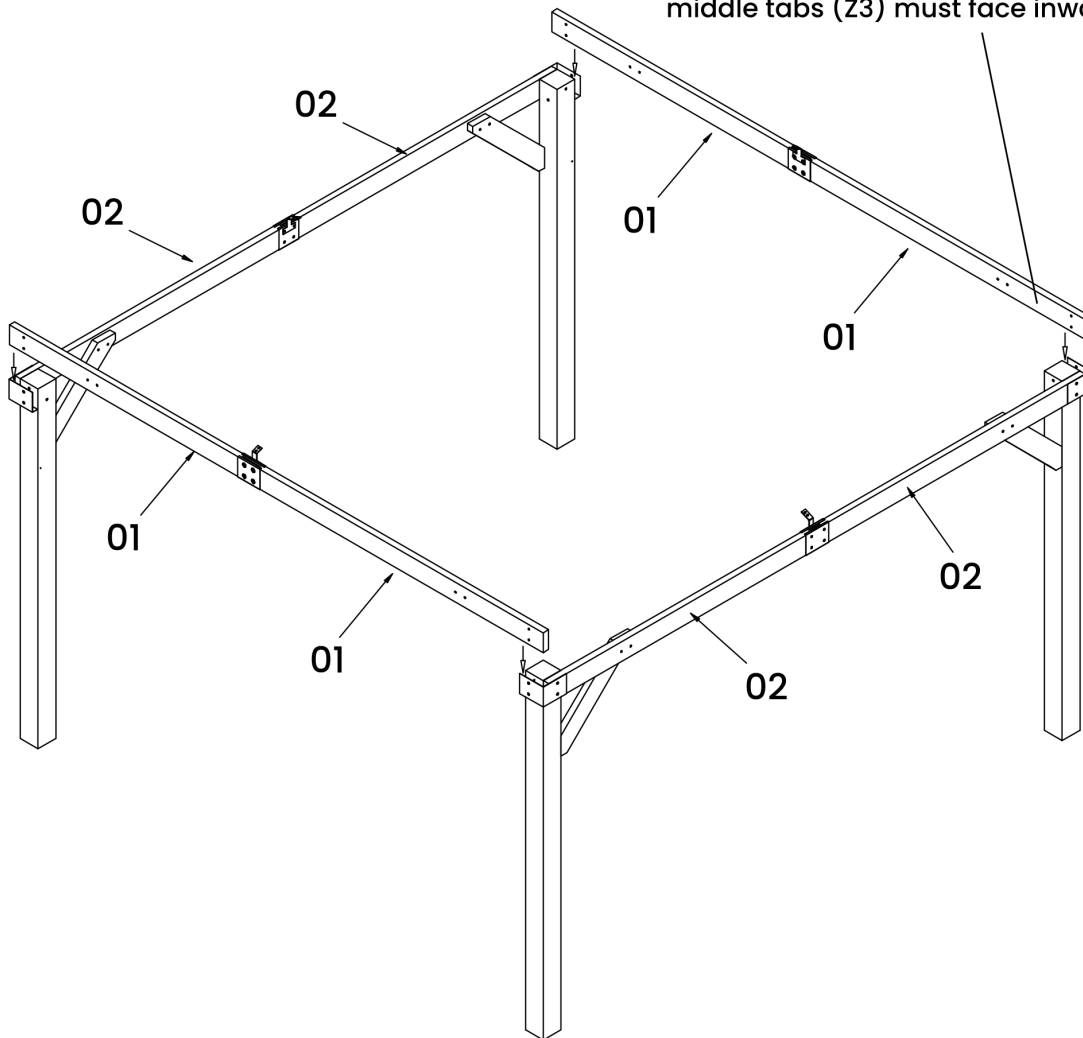

# STEP 6

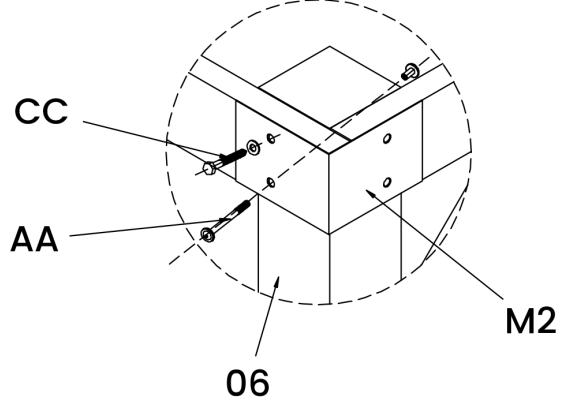
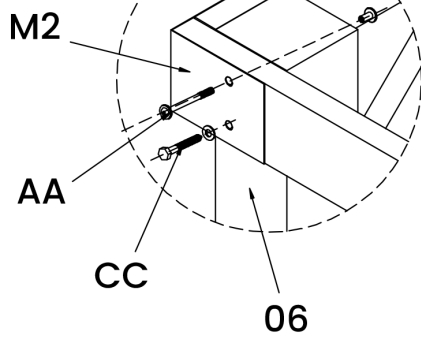
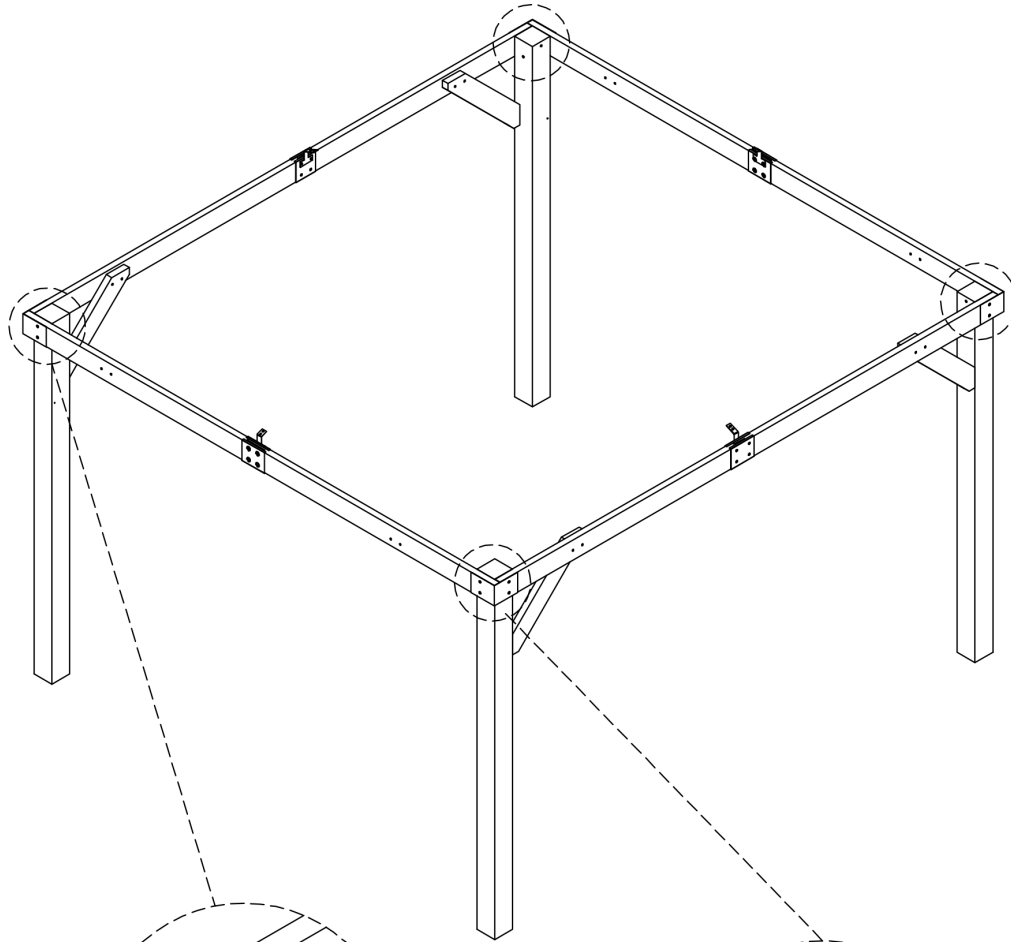

  
M8X165 (AA) 4pcs

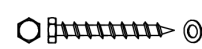
  
M10\*80 (CC) 4pcs

## STEP 7

$\angle R = 90^\circ$   $Y1 = Y2$

**TIPS:**

Check the frame is squared by measuring from one post to the opposite post diagonally and also the angles of the legs are at 90 degree angles.

First pre-install bolts HH (do not tighten), then tighten bolts DD on timber 04 and 06. Finally tighten the pre-installed screws HH.

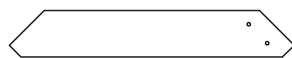
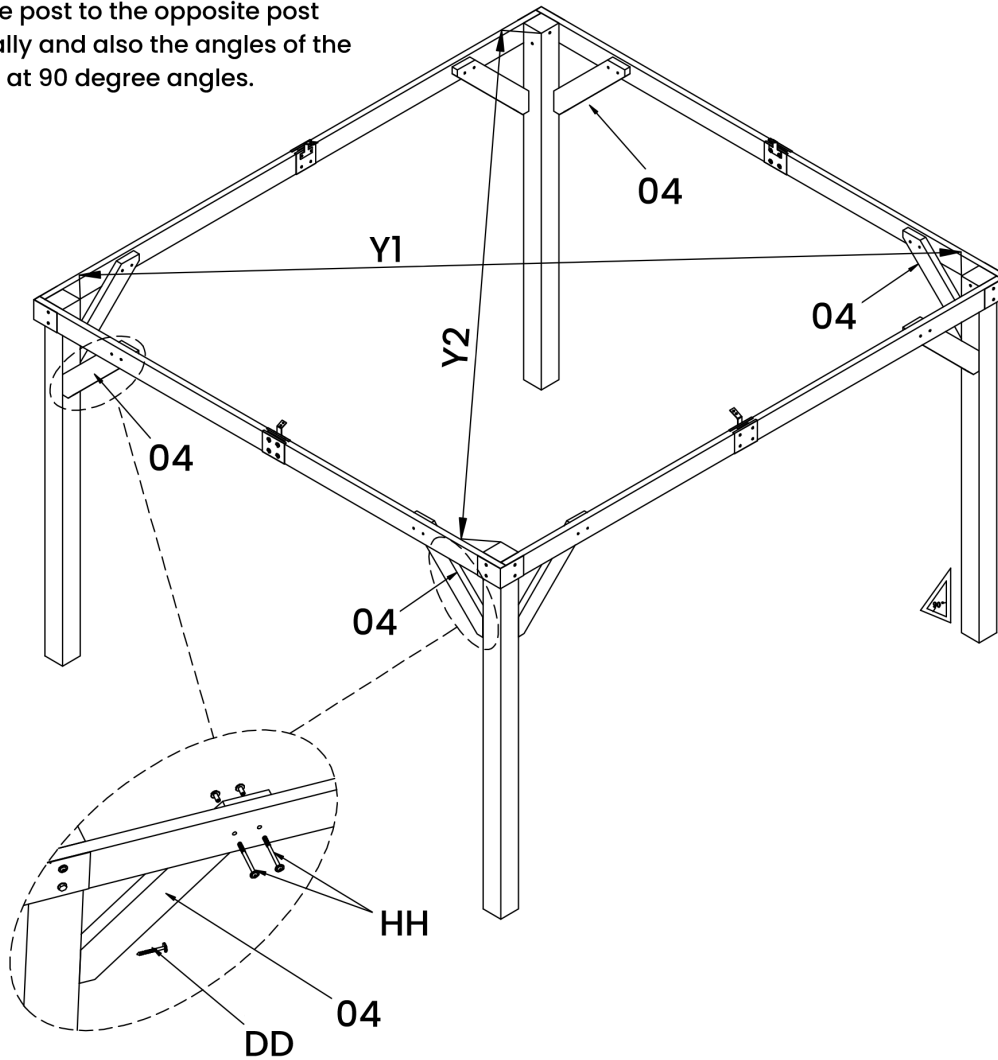

④ 4pcs

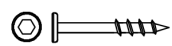

M6\*70

ⓓ 4pcs



M8X60

ⓓ 8pcs

# STEP 8

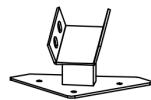
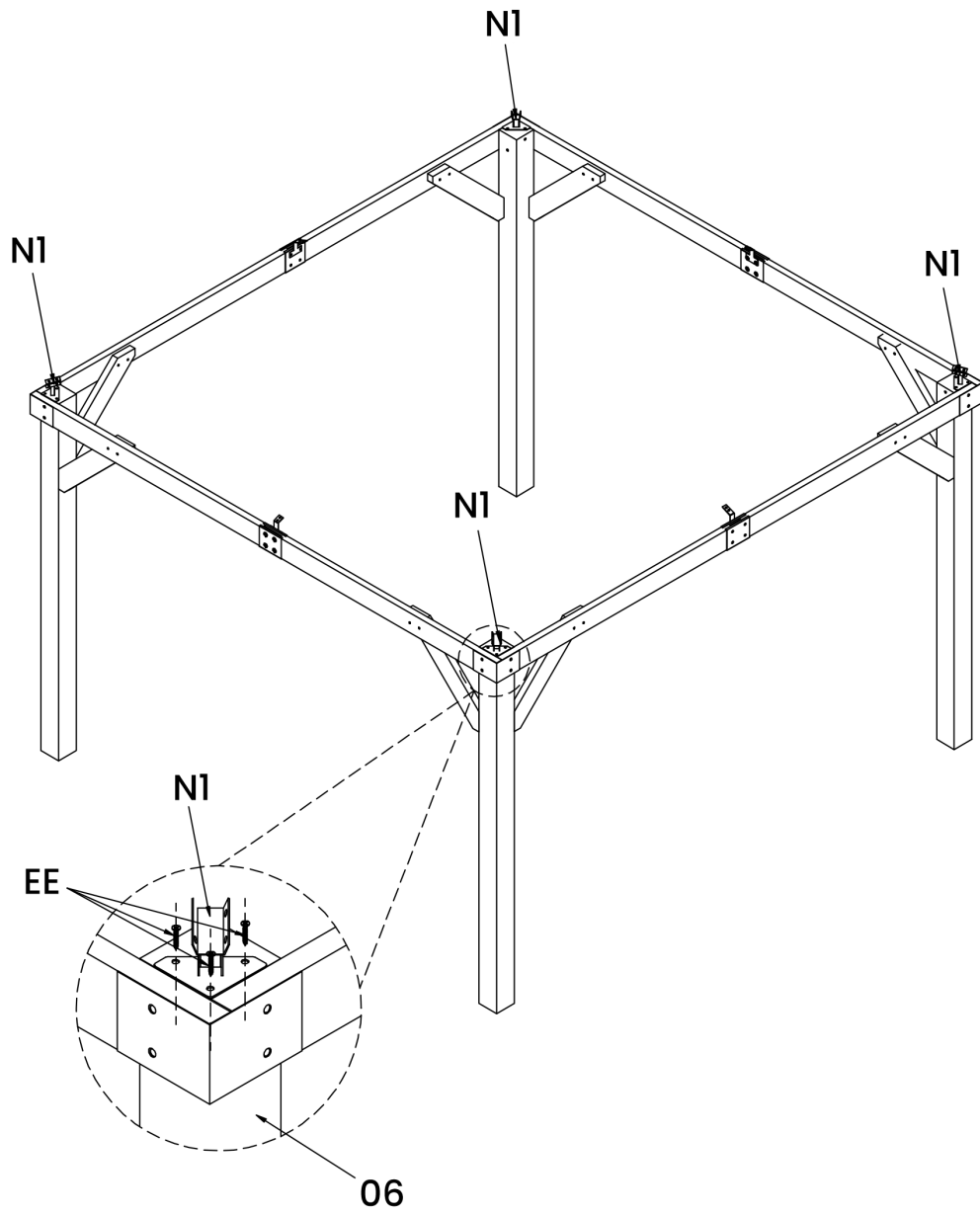

**(N1)** 4pcs

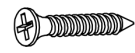

**M5X40**

**(EE)** 12pcs



# STEP 9

Warning: Gloves should be worn when handling steel roof pieces and sheets.

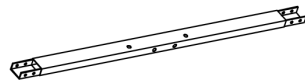
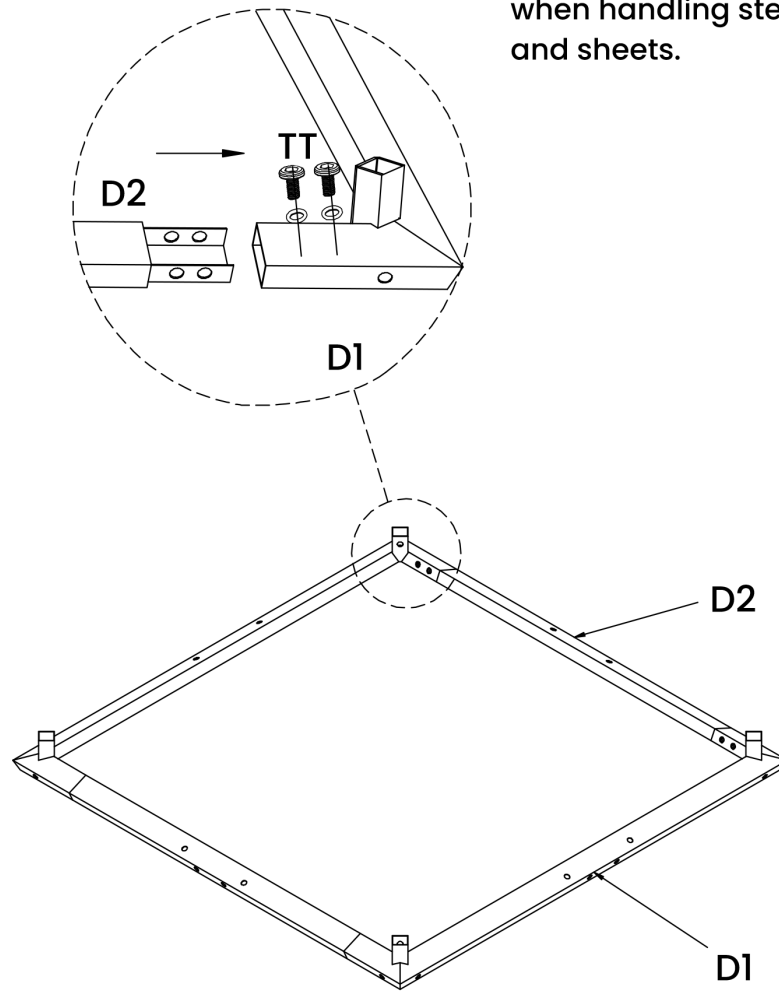

**D2** 2pcs

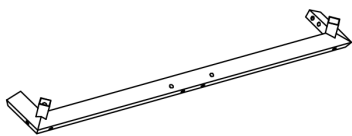

**D1** 2pcs



M6X15

**TT** 8pcs

# STEP 10

Warning: Please seek assistance to support the parts while one person installs the screws.

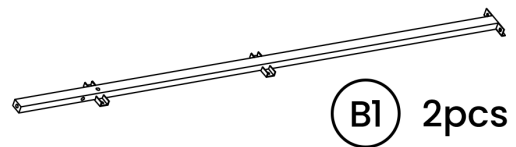
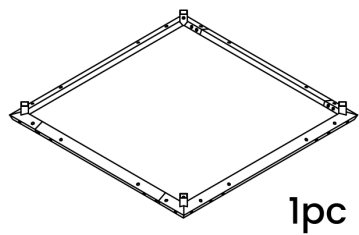
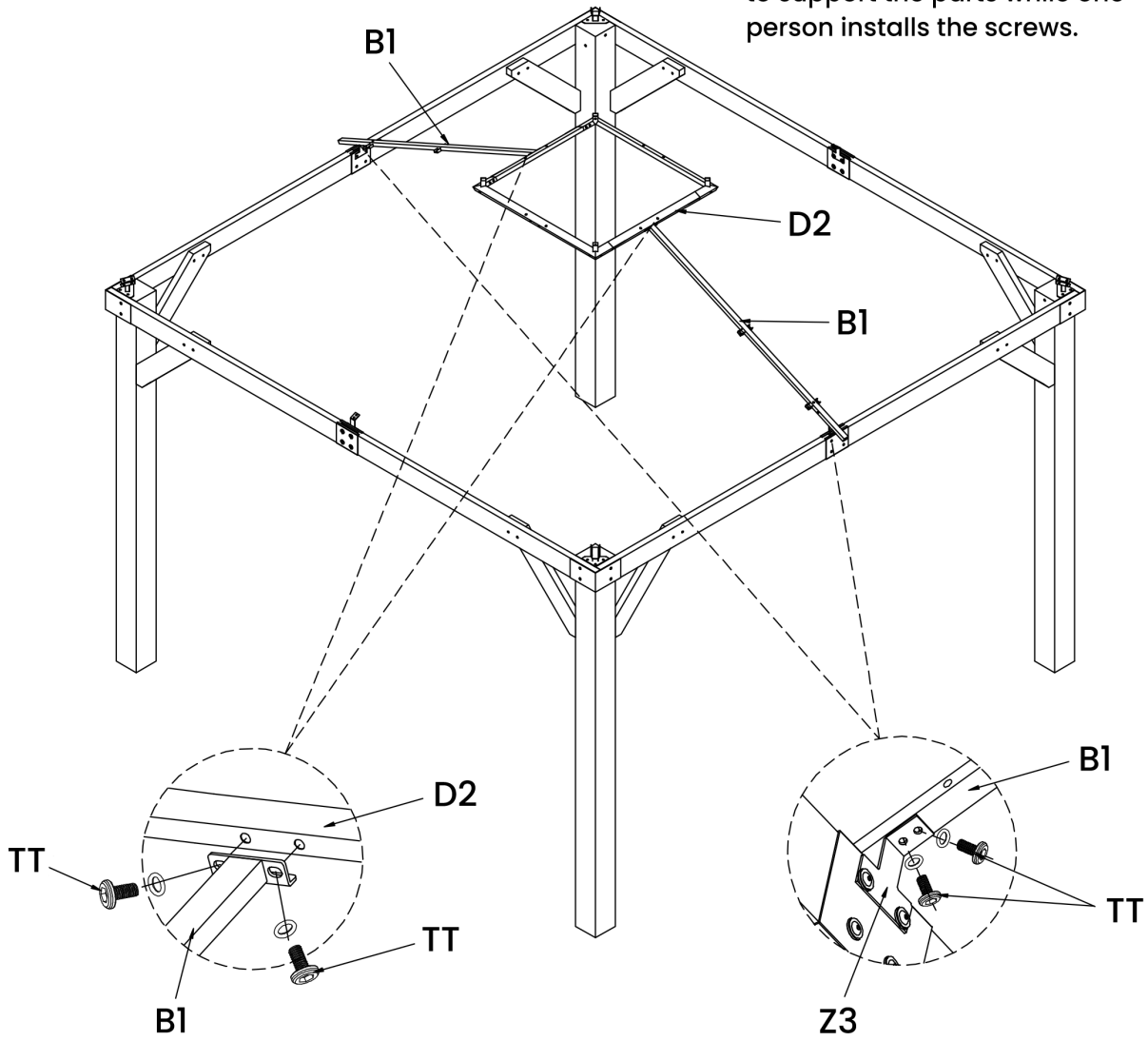

# STEP 11

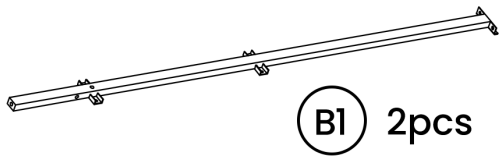
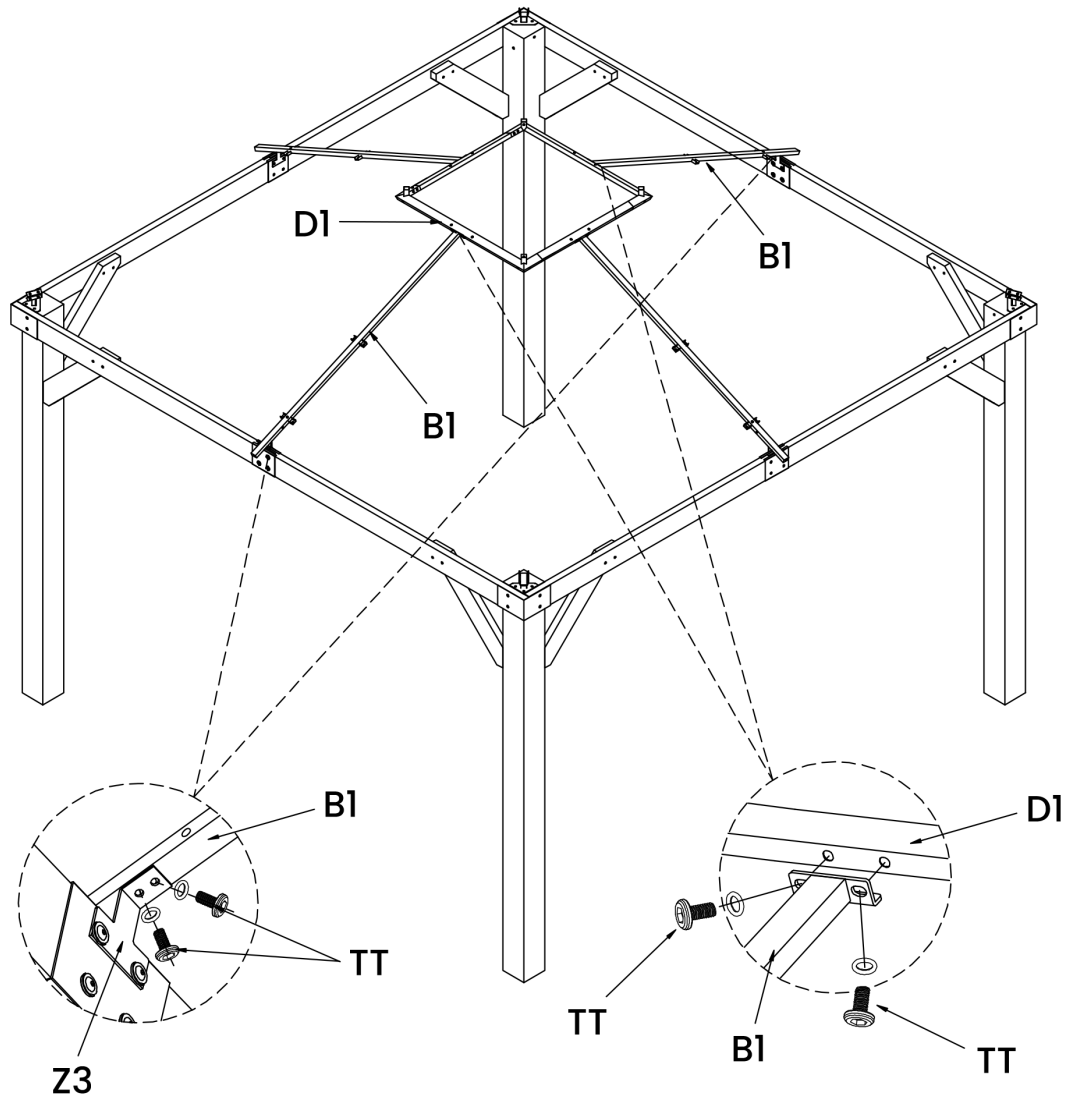

**B1** 2pcs

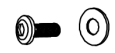

**M6X15**

**TT** 8pcs

## STEP 12

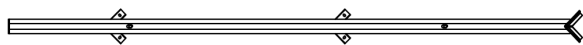
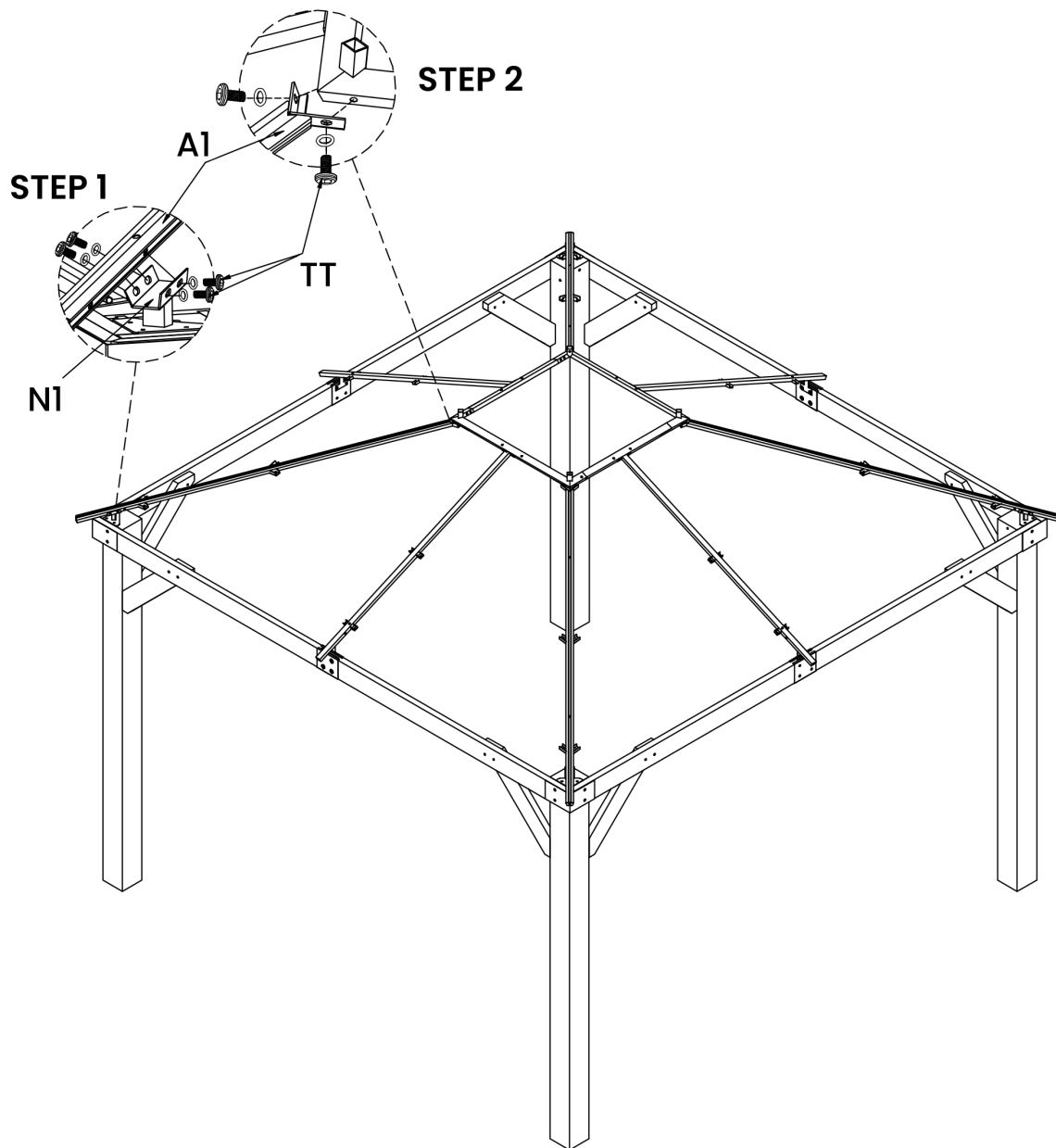

**(A1)** 4pcs



**M6X15**

**(TT)** 24pcs

### STEP 13

Push down until it locks into the hole on D1.

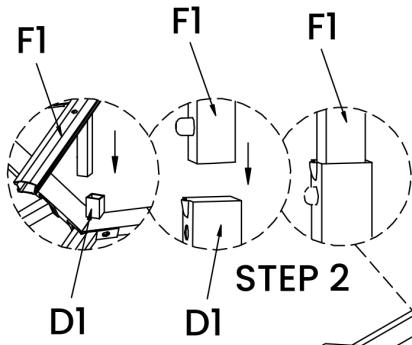

L2 Push in F1 until it locks into hole on L2.

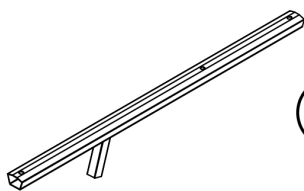
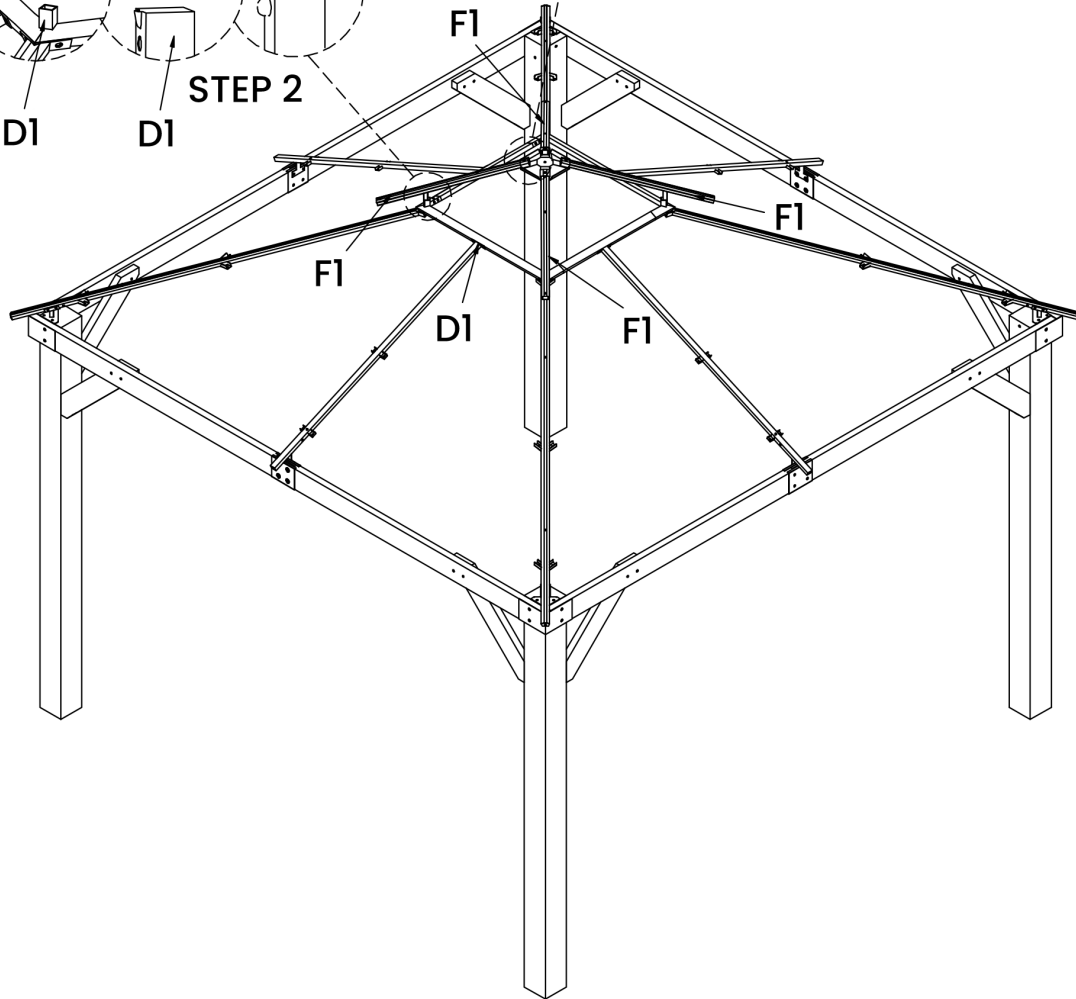
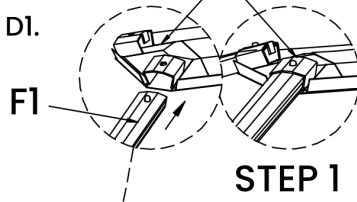

F1 4pcs

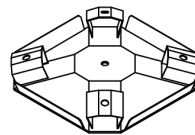

L2 1pc

# STEP 14

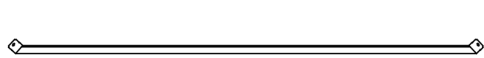
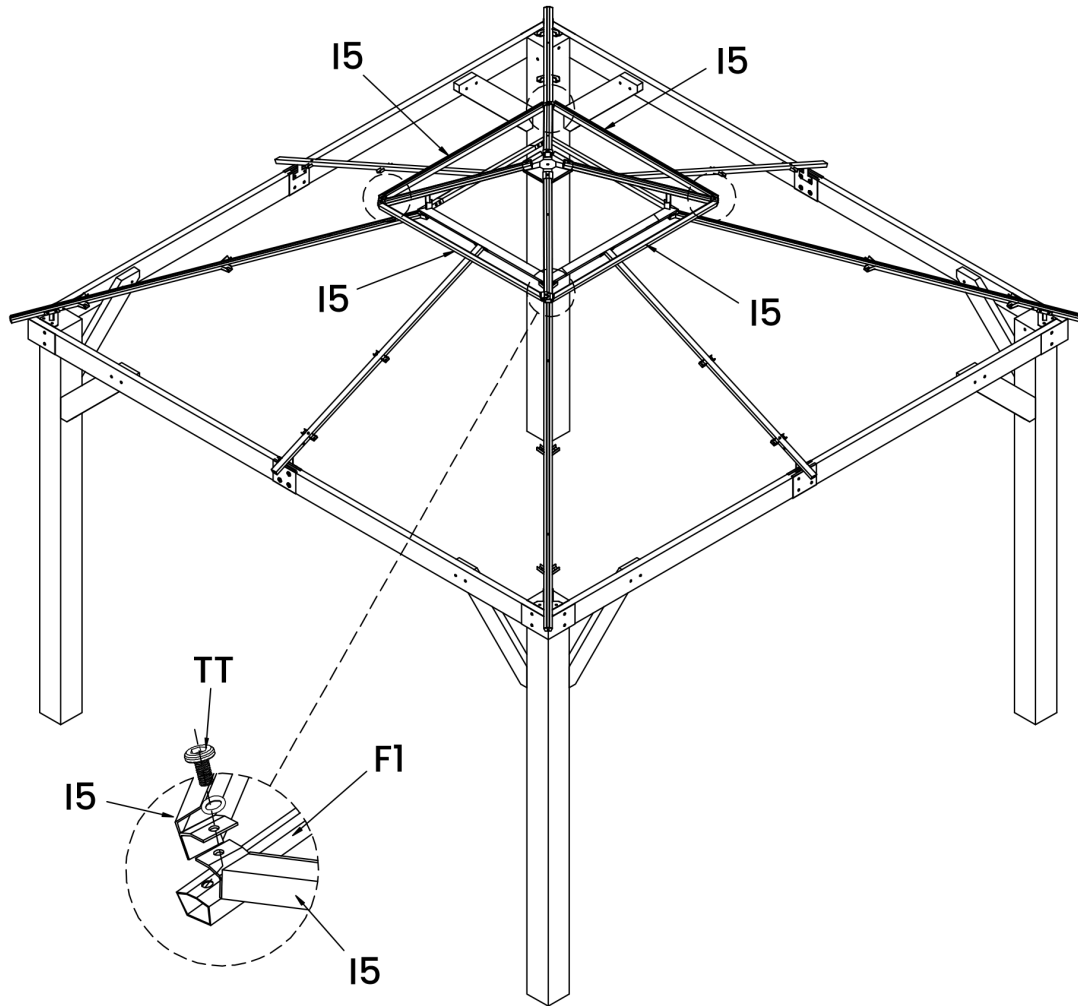

(I5) 4pcs



(TT) 4pcs

## STEP 15

Arrange your roof sheets in the following order.

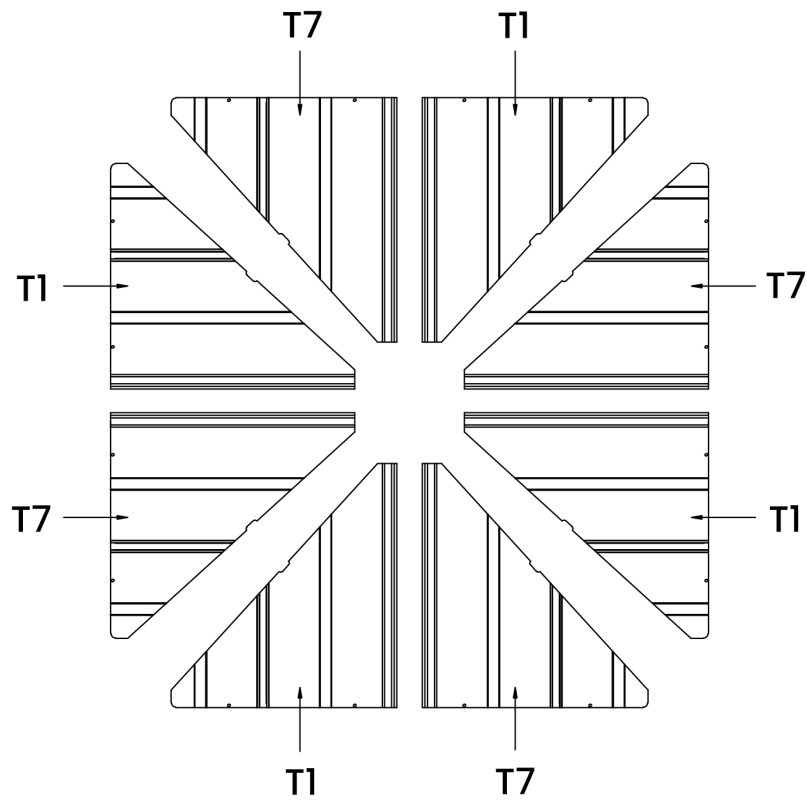

# STEP 16

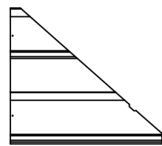
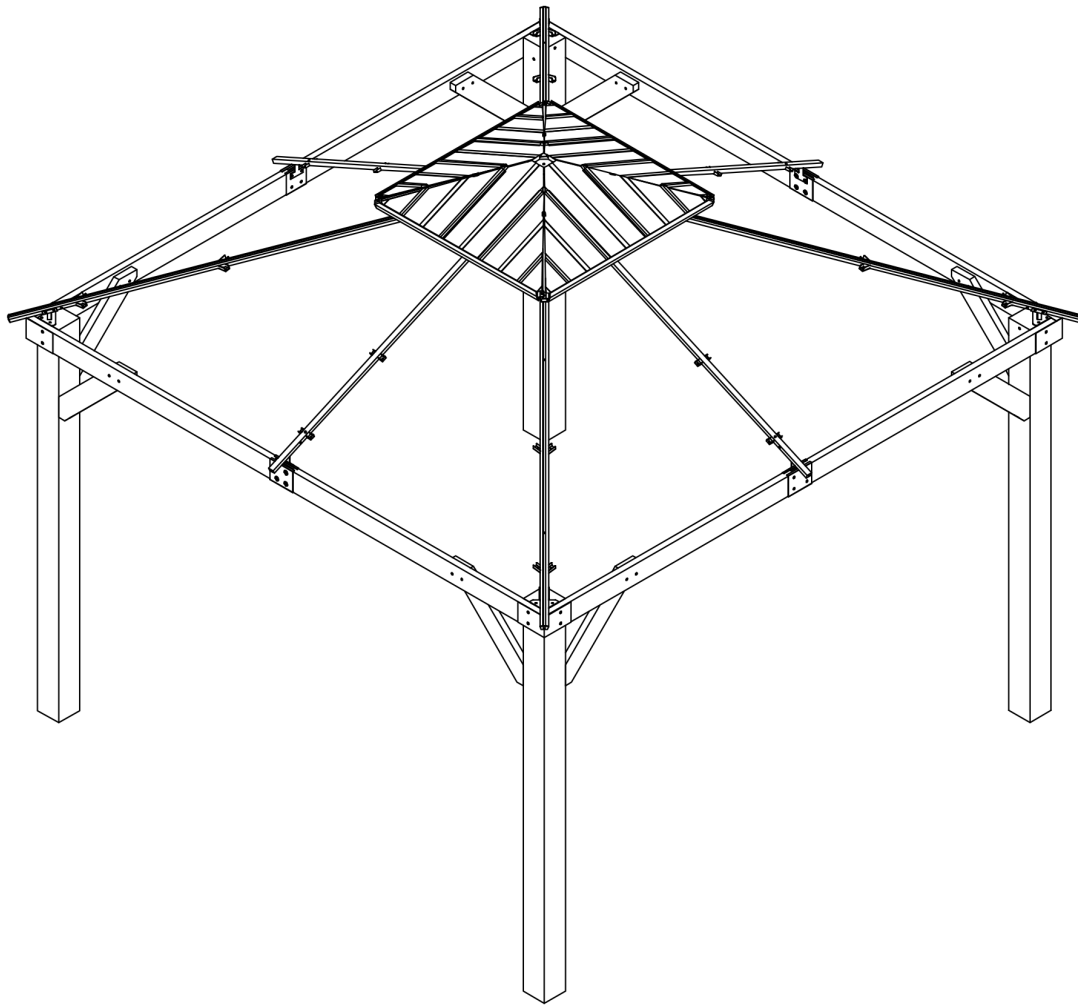
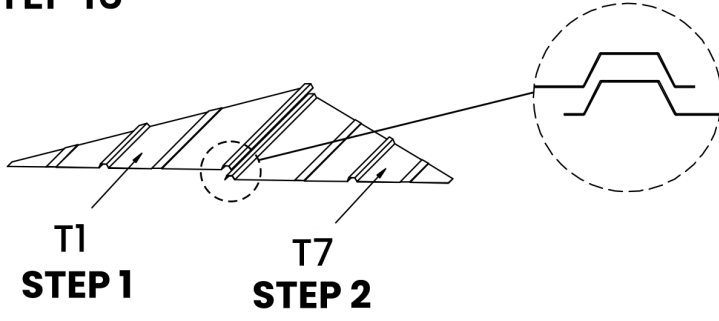

T1 4pcs

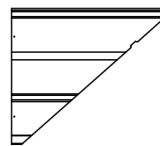

T7 4pcs



## STEP 17

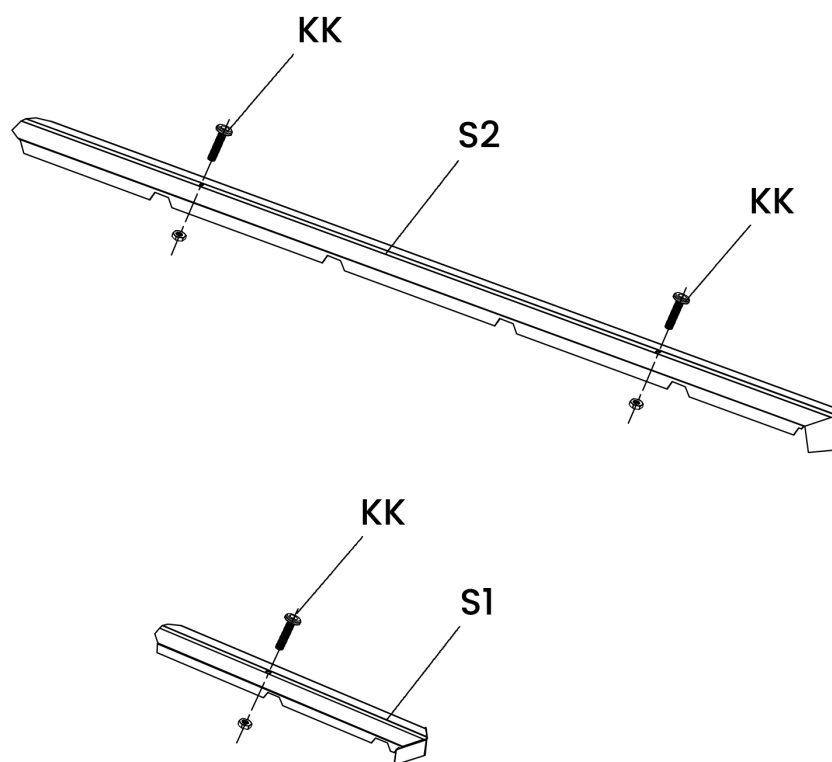

Secure the screws (KK) on to S1 and S2.



(S1) 4pcs



(S2) 4pcs



(KK) 12pcs

M6\*55

# STEP 18

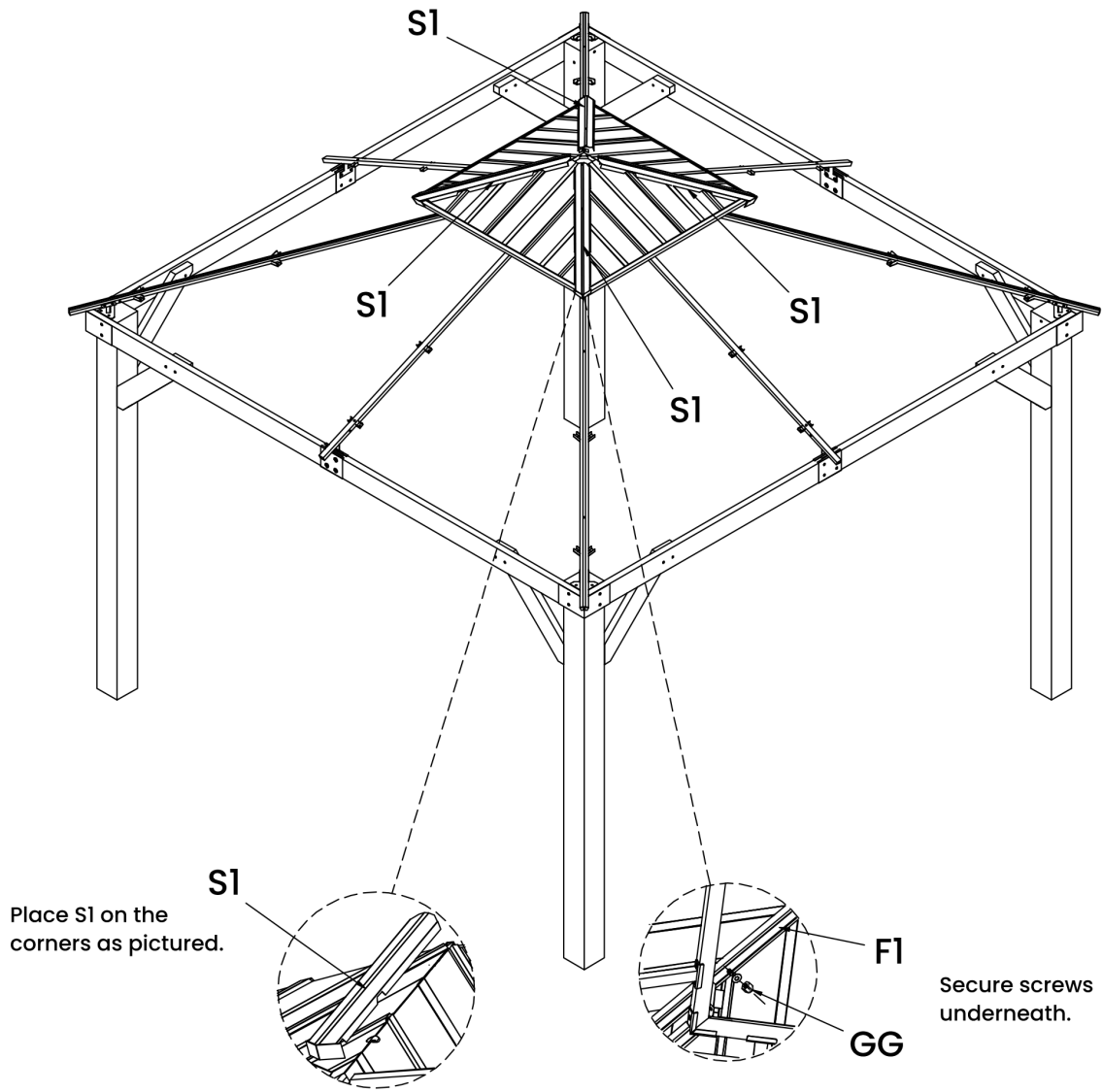

**S1** 4pcs



**GG** 4pcs

# STEP 19

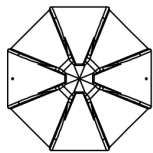
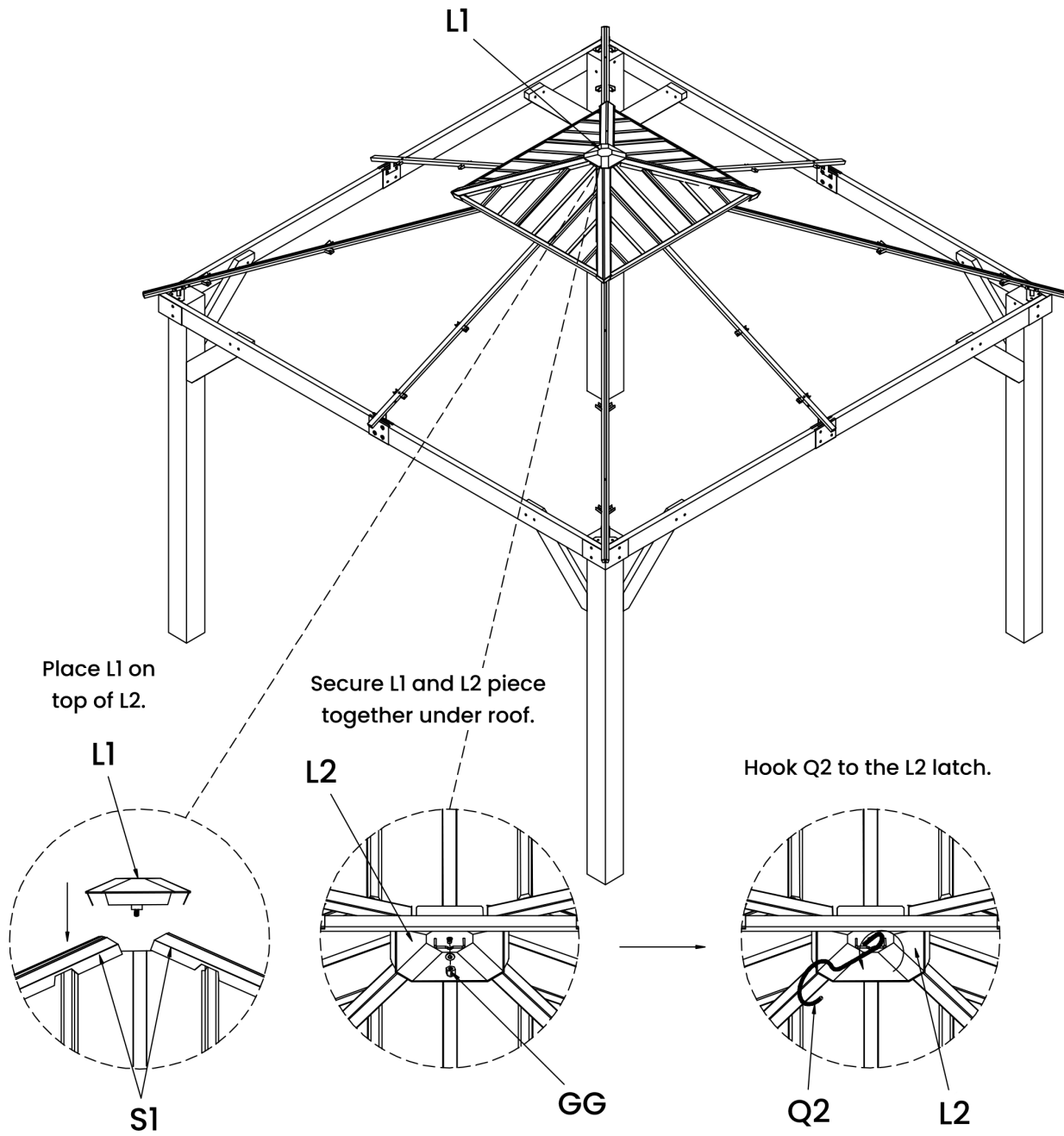

L1 1pc



GG 1pc



Q2 1pc

# STEP 20

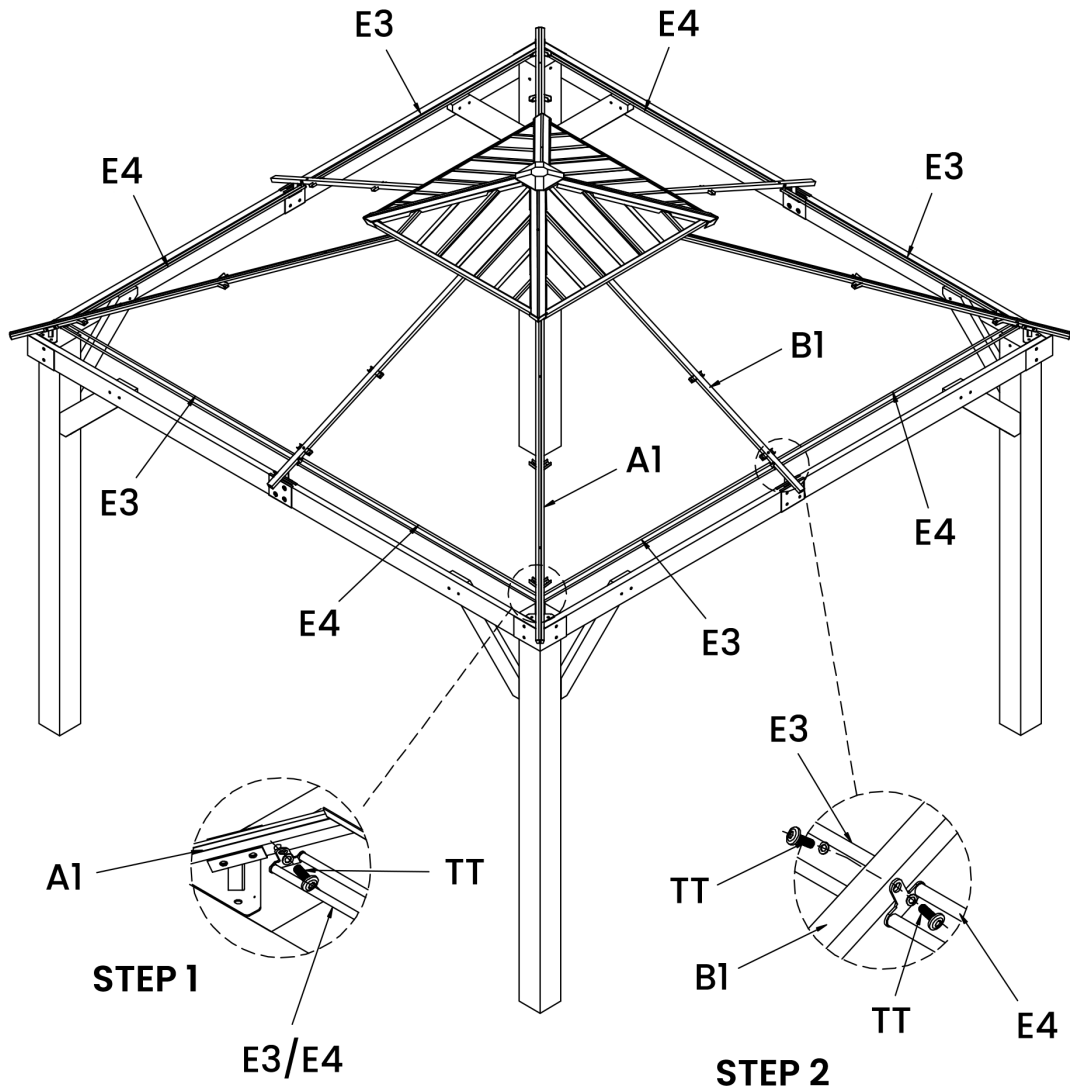

**E3** 4pcs



**E4** 4pcs



**M6X15**

**TT** 16pcs

## STEP 21

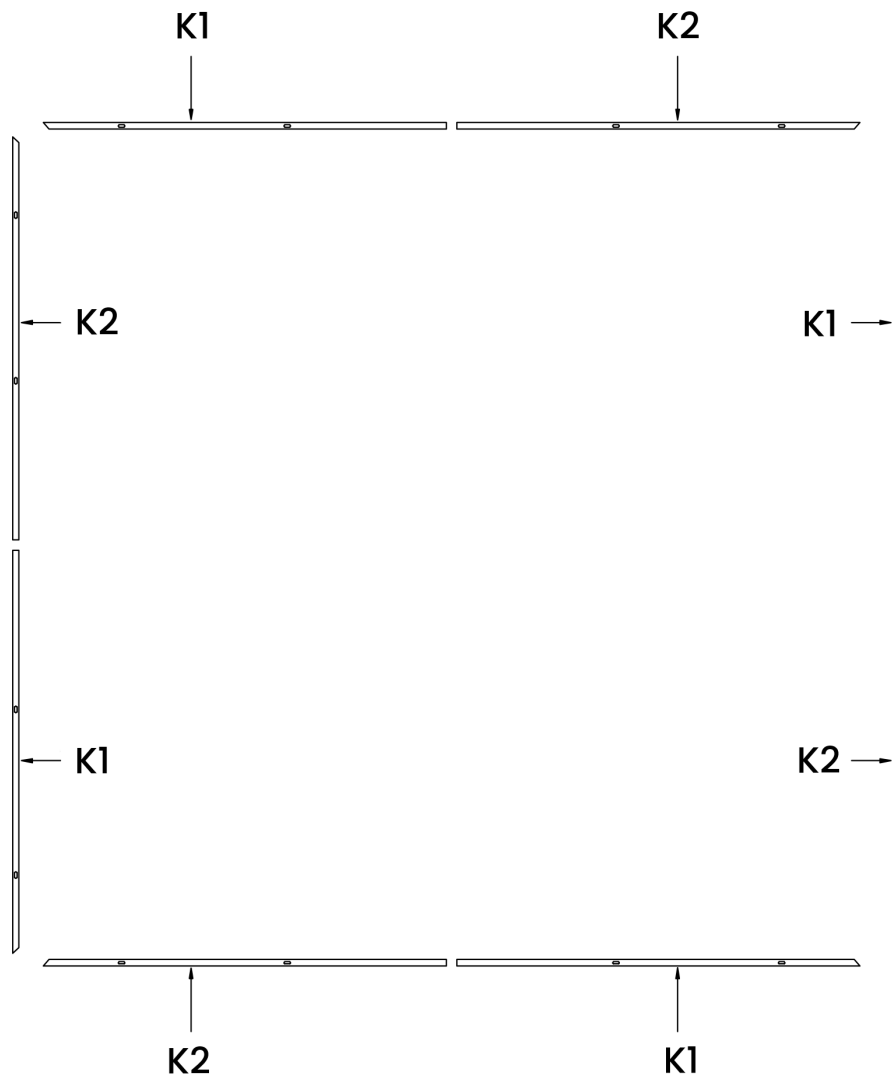

Lay out the K1 and K2 parts in the formation  
pictured for use in next step.

## STEP 22

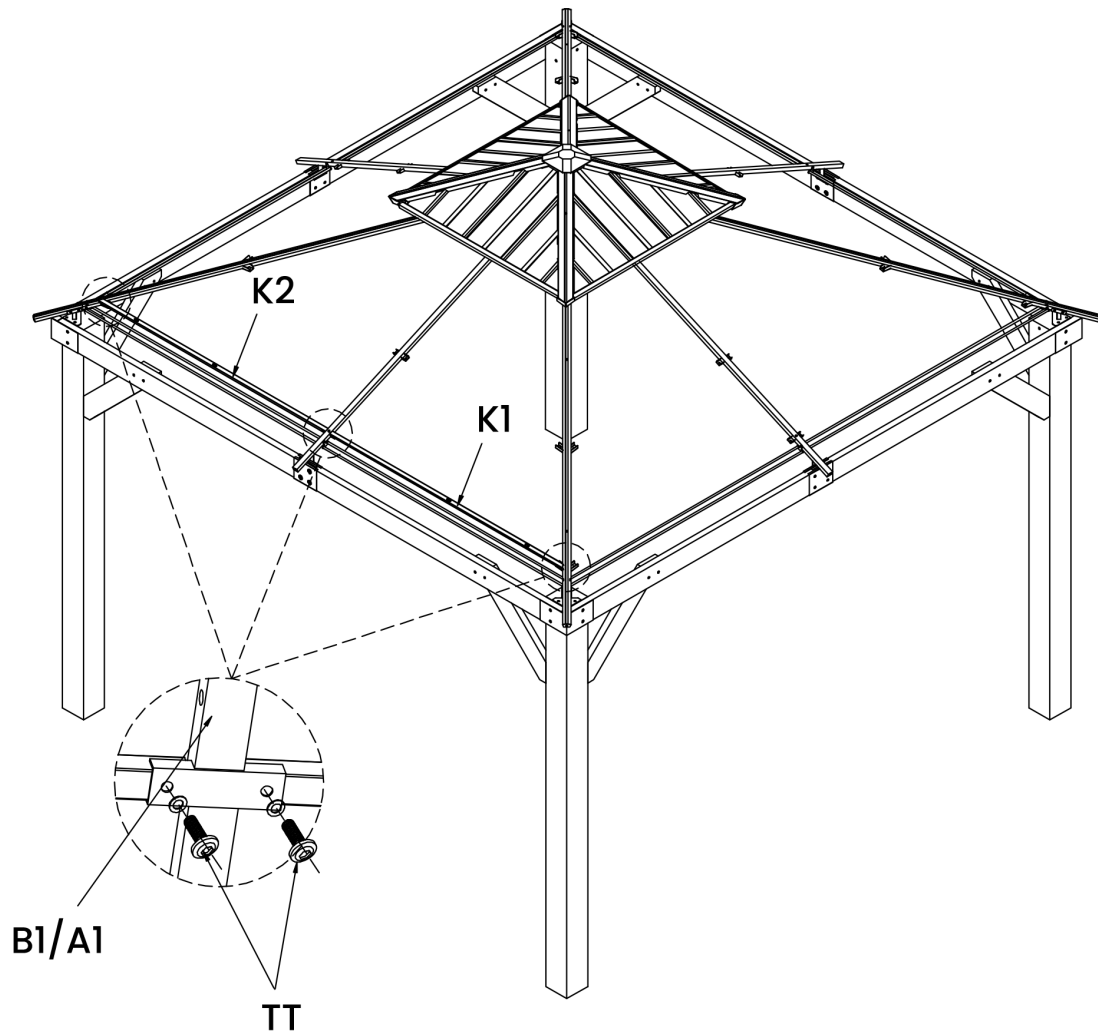

Pre-install the screws but do not tighten.



(K1) 4pcs



(K2) 4pcs



(TT) 16pcs

M6X15

**STEP 23**

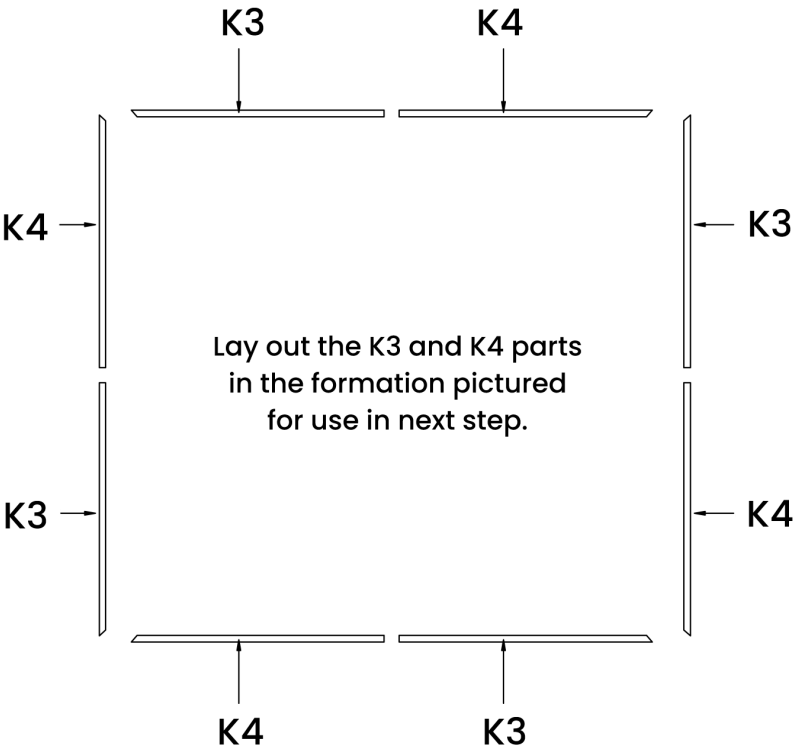

## STEP 24

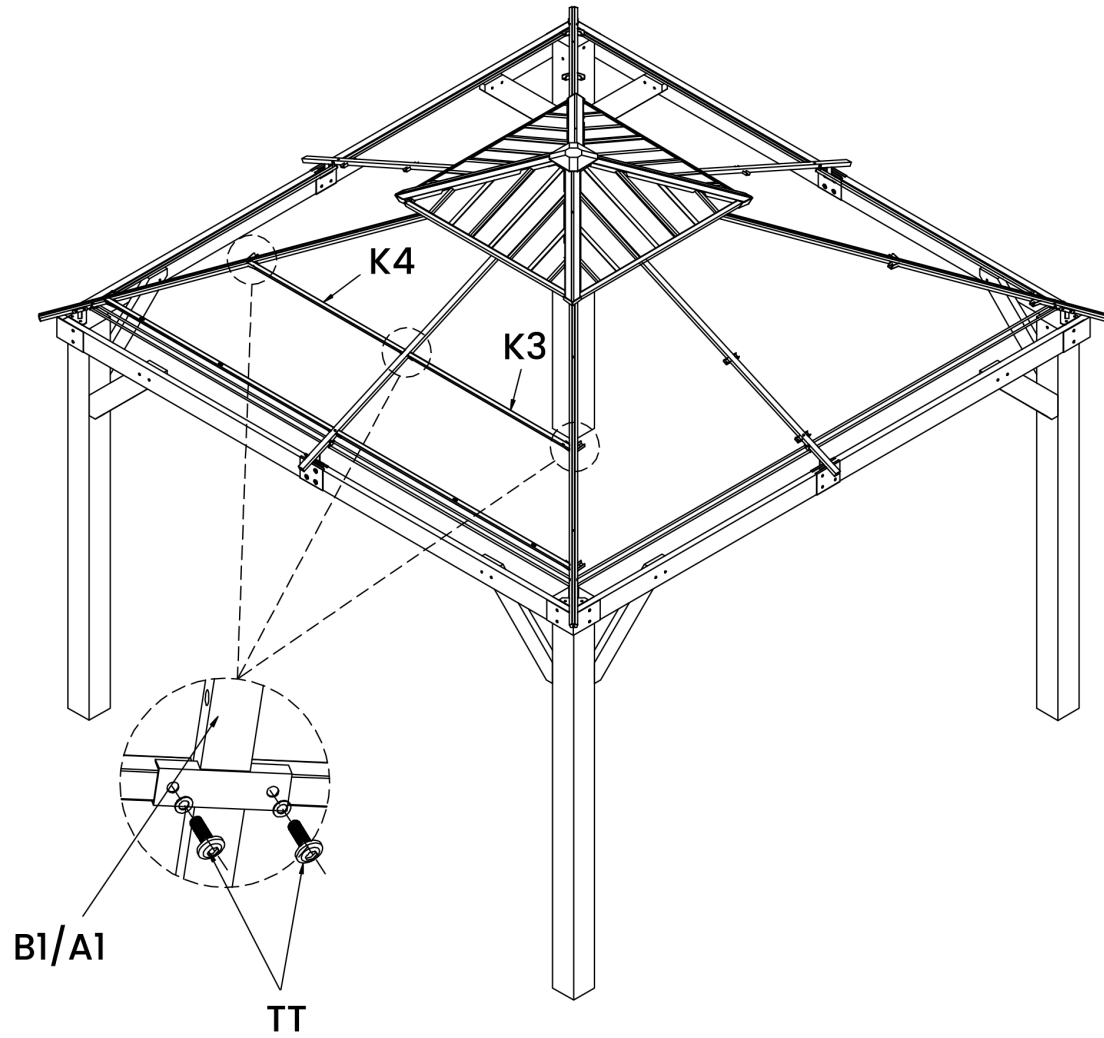

Pre-install the screws but do not tighten.



(K3) 4pcs



(K4) 4pcs



M6X15



(TT) 4pcs



## STEP 25

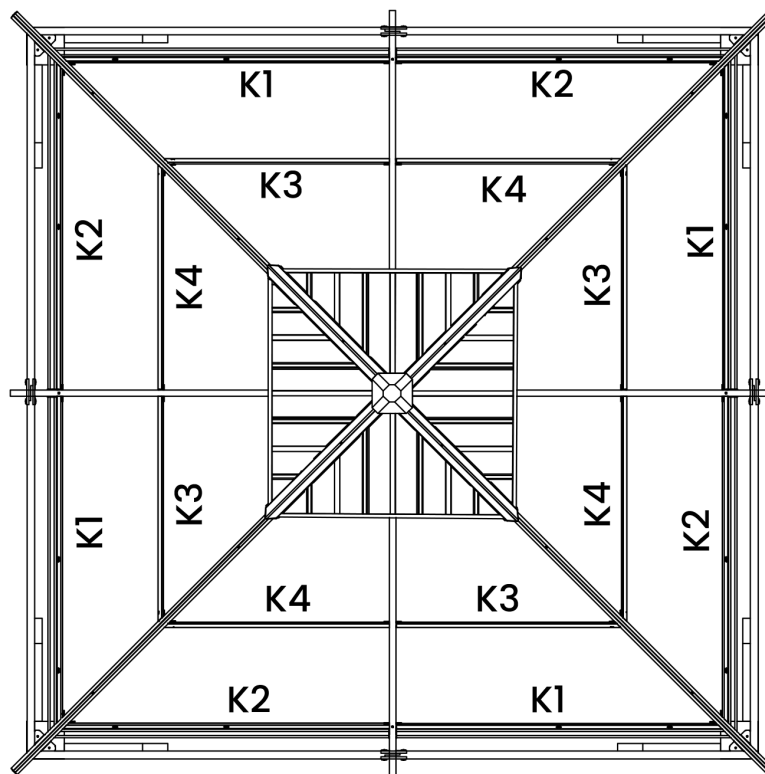
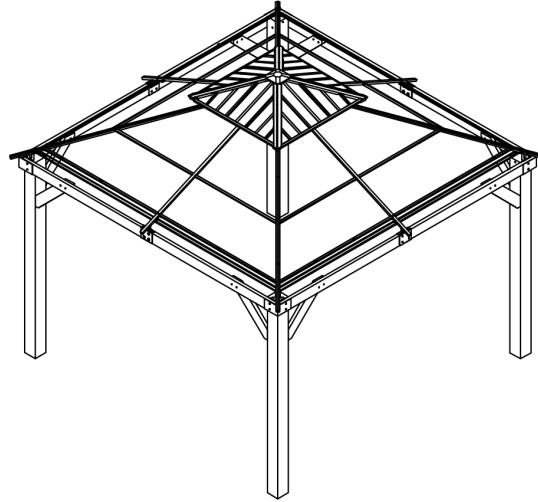

Refer to steps 20-21 and secure the bolts on all sides.

## STEP 26

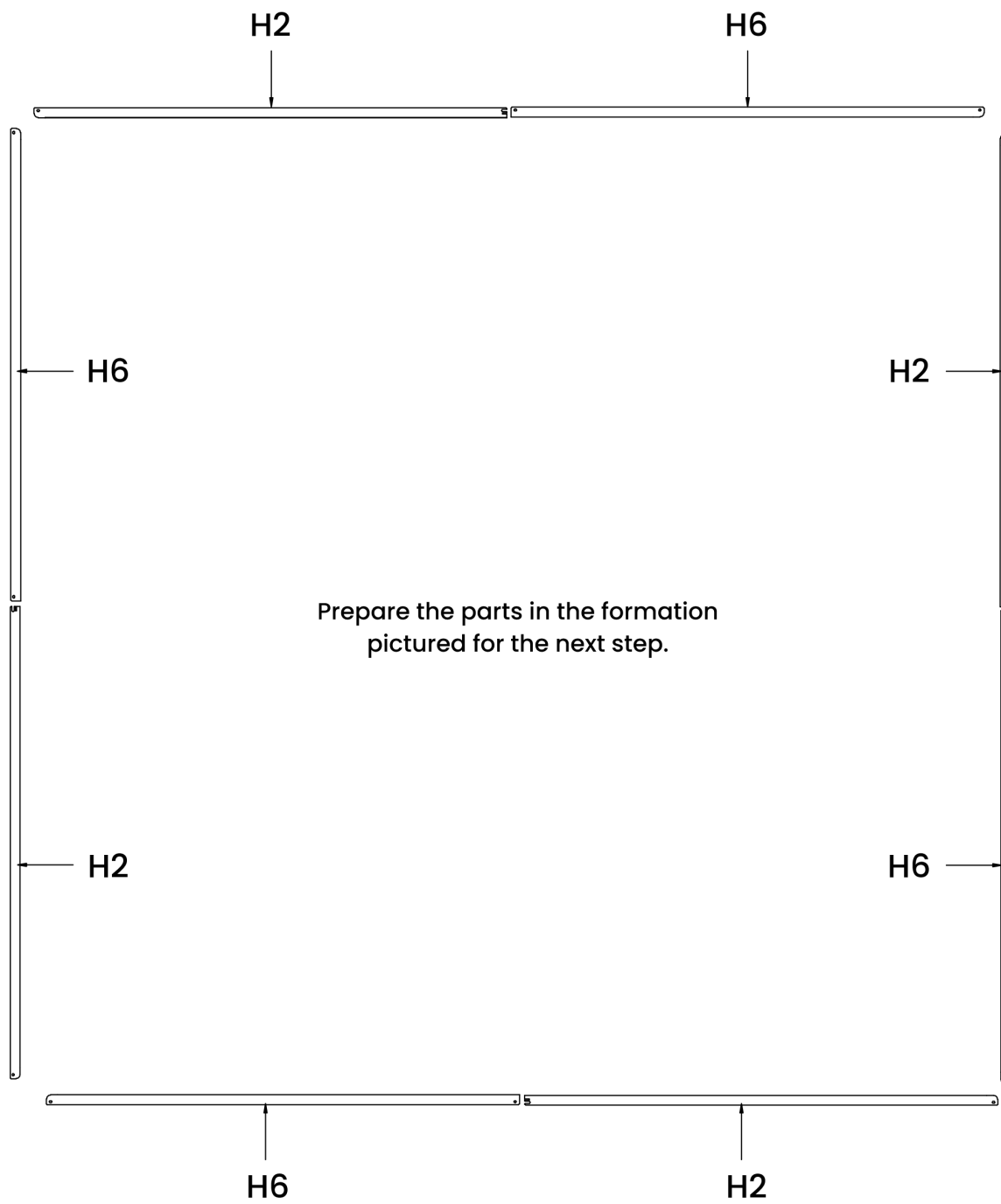

**STEP 27**

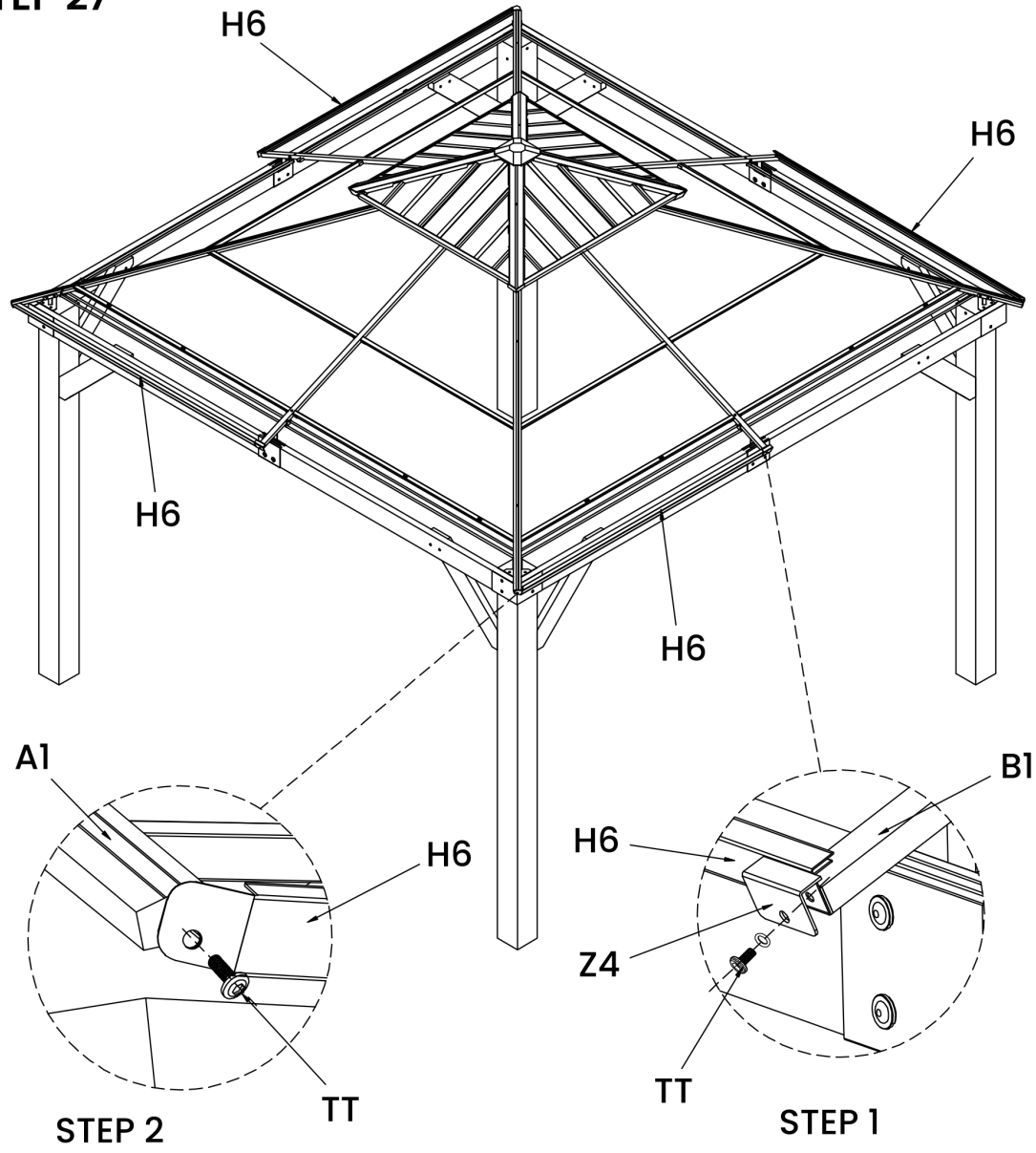

Pre-install the screws but do not tighten.

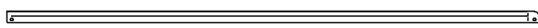

**(H6)** 4pcs



**(Z4)** 4pcs



**M6X15 (TT)** 4pcs

## STEP 28

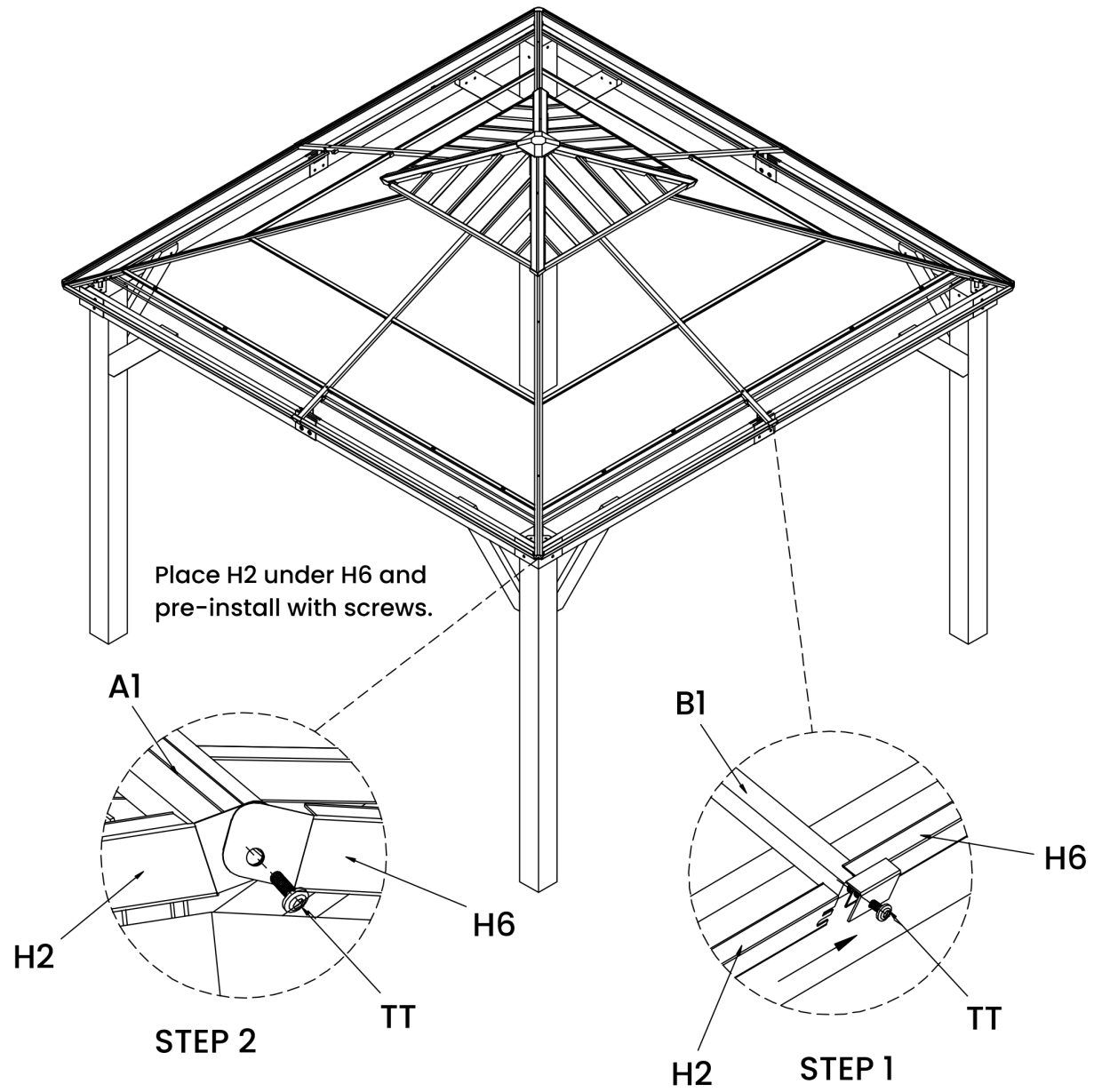

**H2** 4pcs

**STEP 29**

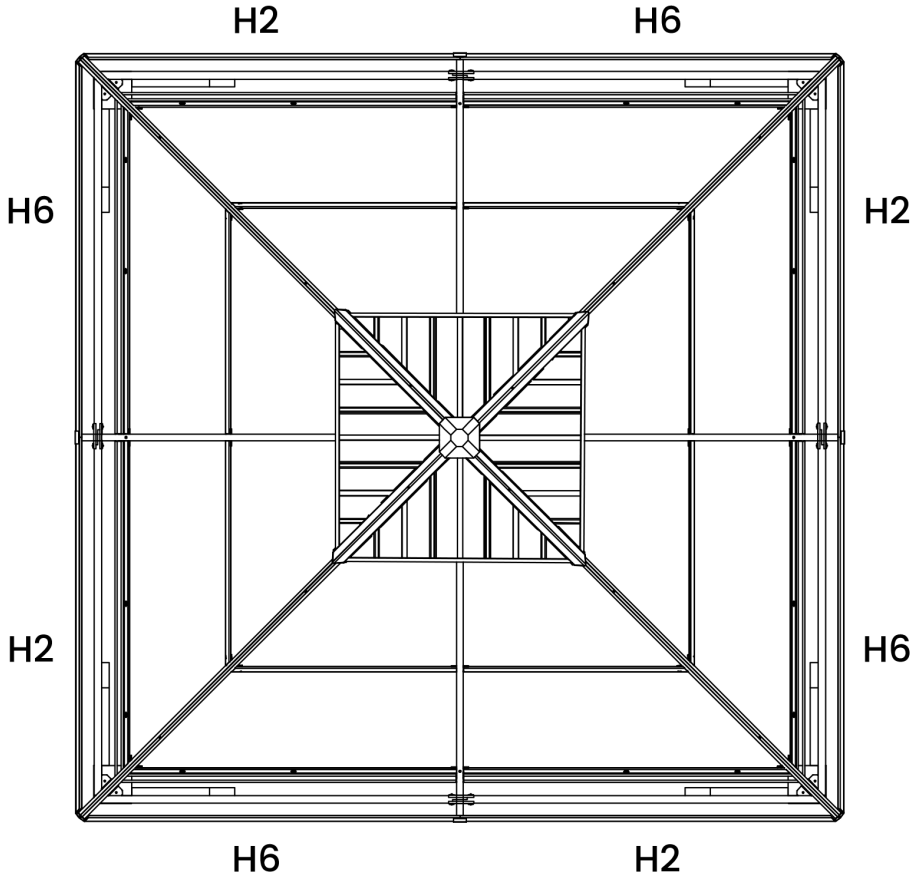
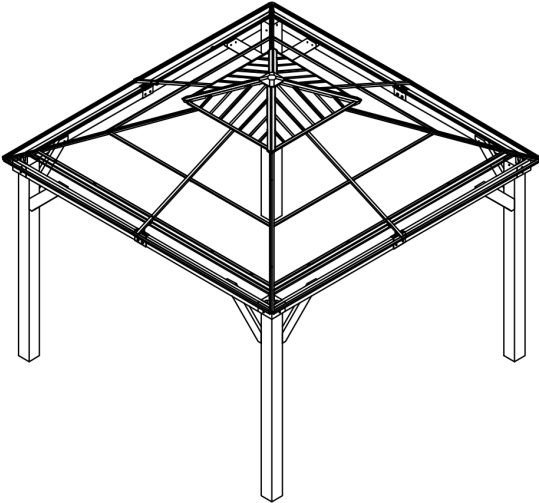

Refer to step 23-24 to complete H2/H6 and tighten all the pre-installed screws.

## STEP 30

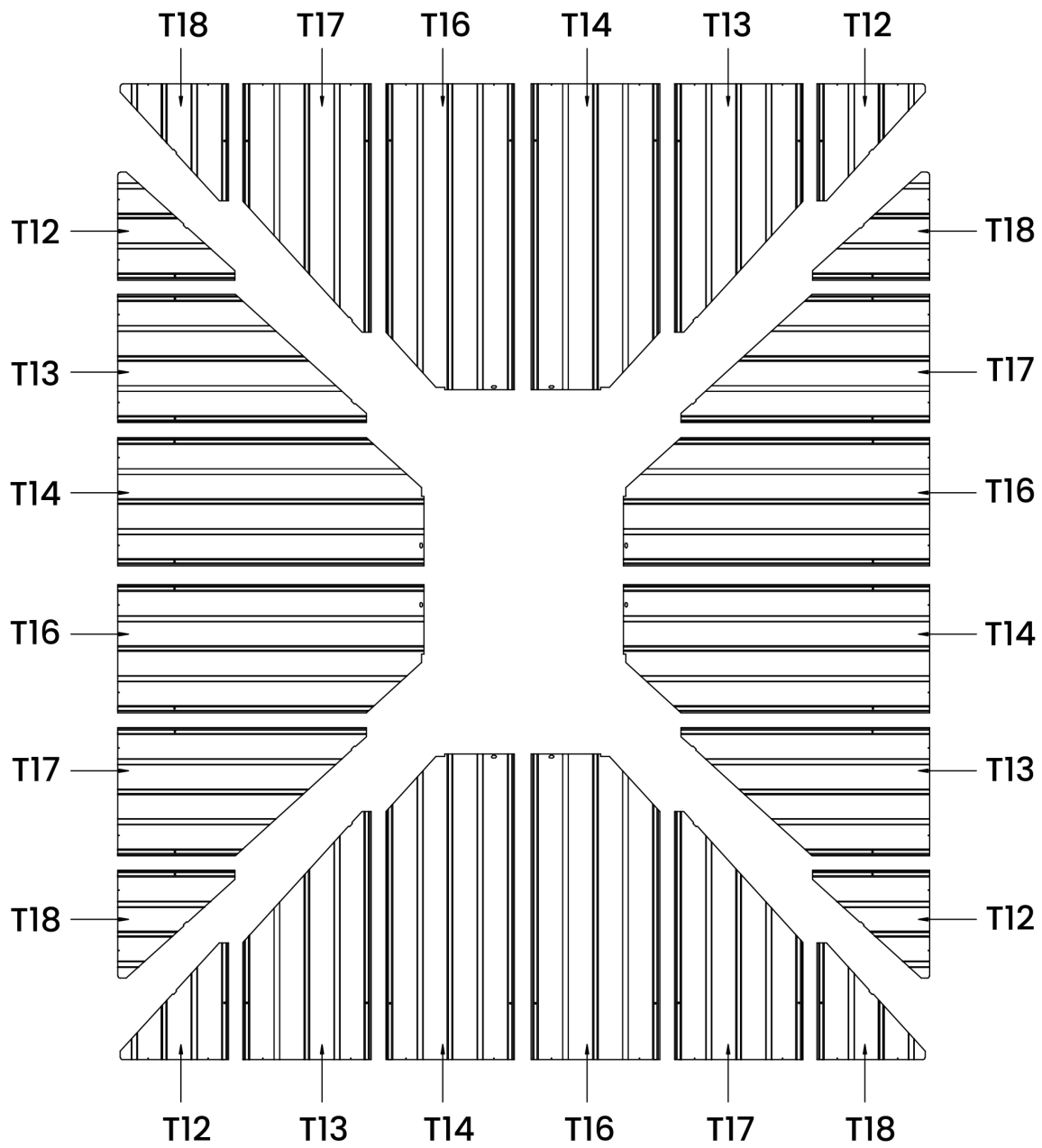

Arrange the roof panels in the following formation.

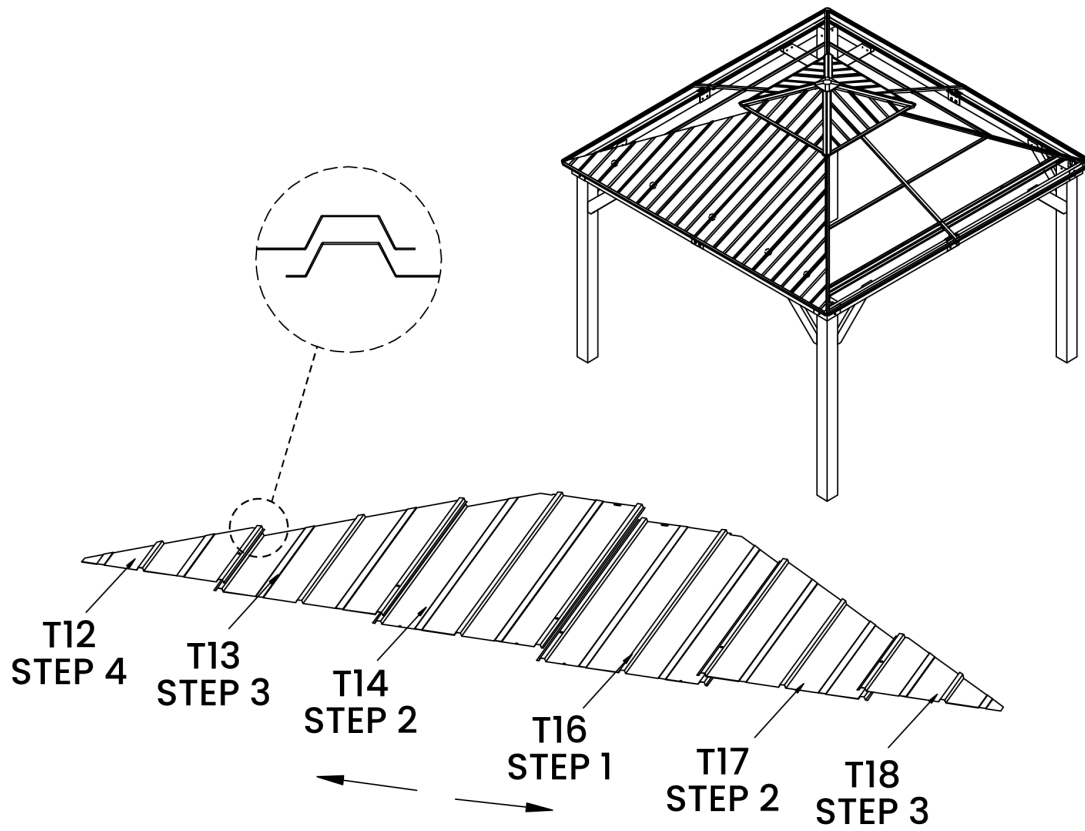

# STEP 31



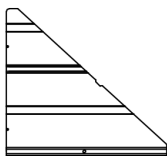
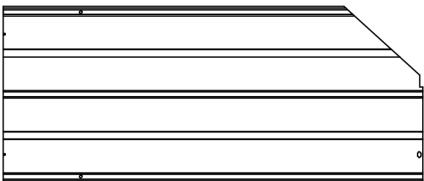

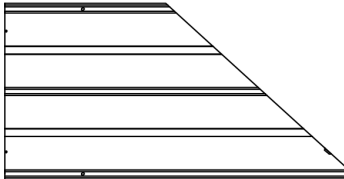
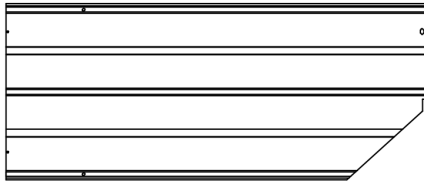
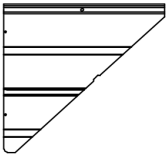

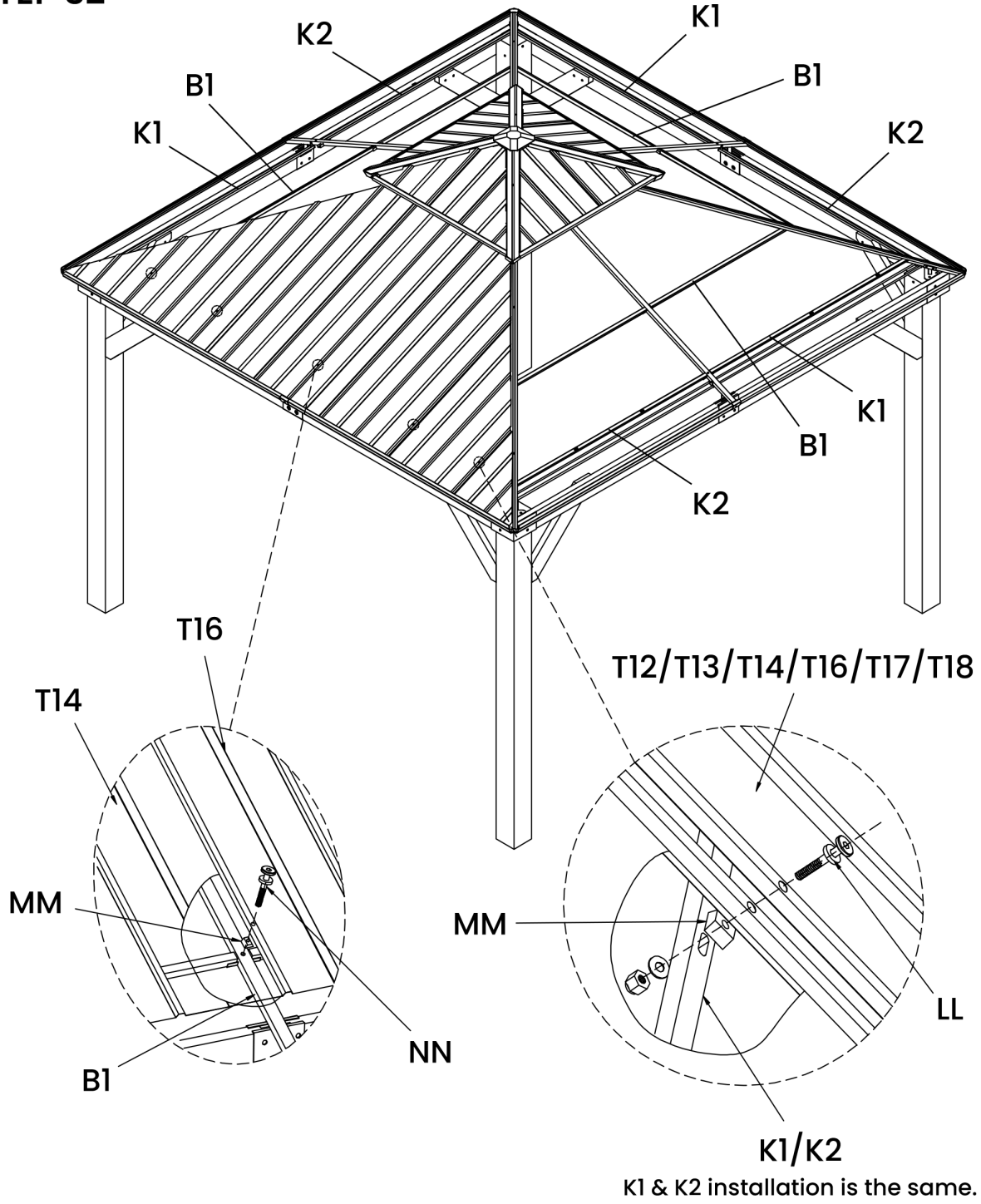

Start from the middle and work your way out. Overlap the sheeting by one ridge.

	<p>(T12) 4pcs</p>		<p>(T14) 4pcs</p>		<p>(T17) 4pcs</p>		<p>(T13) 4pcs</p>		<p>(T16) 4pcs</p>		<p>(T18) 4pcs</p>
-------------------------------------------------------------------------------------	-----------------------	-------------------------------------------------------------------------------------	-----------------------	-------------------------------------------------------------------------------------	-----------------------	--------------------------------------------------------------------------------------	-----------------------	--------------------------------------------------------------------------------------	-----------------------	---------------------------------------------------------------------------------------	-----------------------

**STEP 32**





  
**M6X25** (NN) 4pcs



  
**M6X45** (LL) 16pcs

 (MM) 20pcs

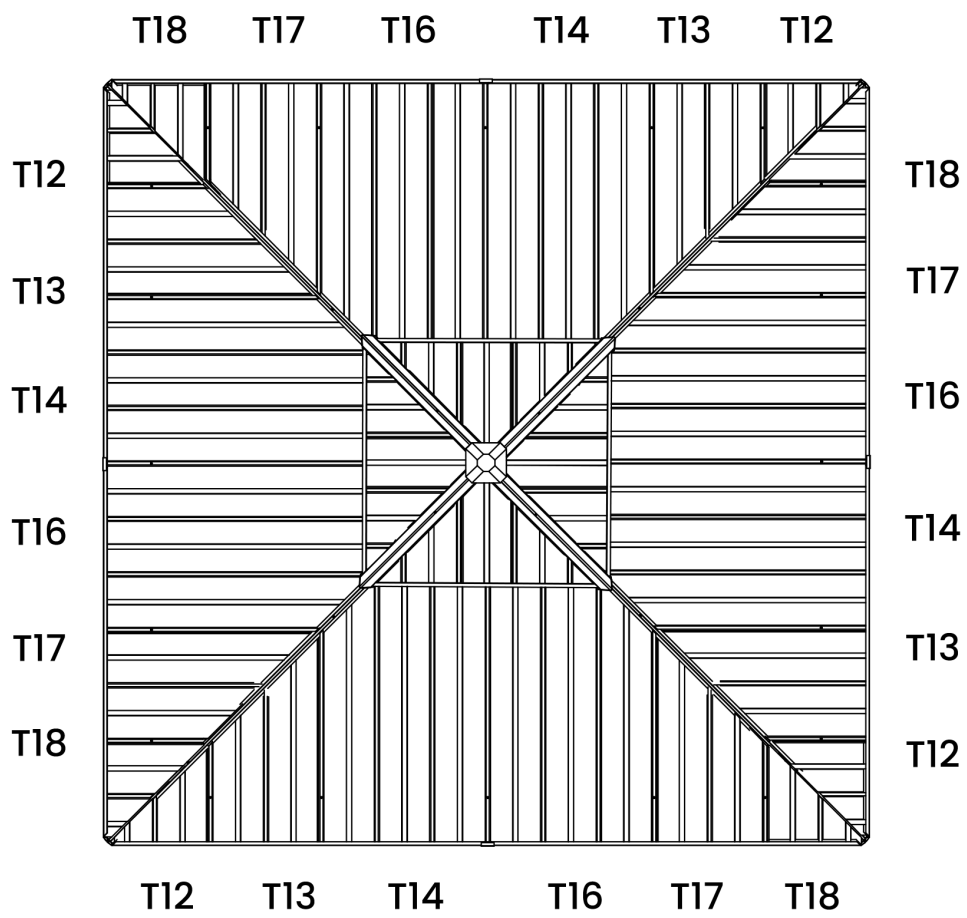
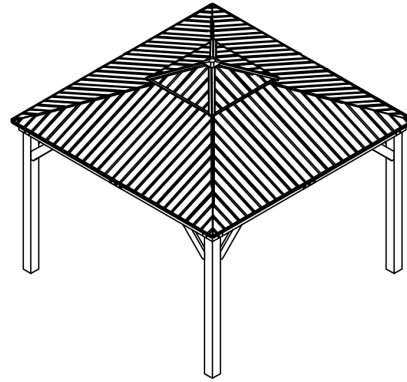

# STEP 33



Refer to steps 26-27 and completely tighten the bolts.

# STEP 34

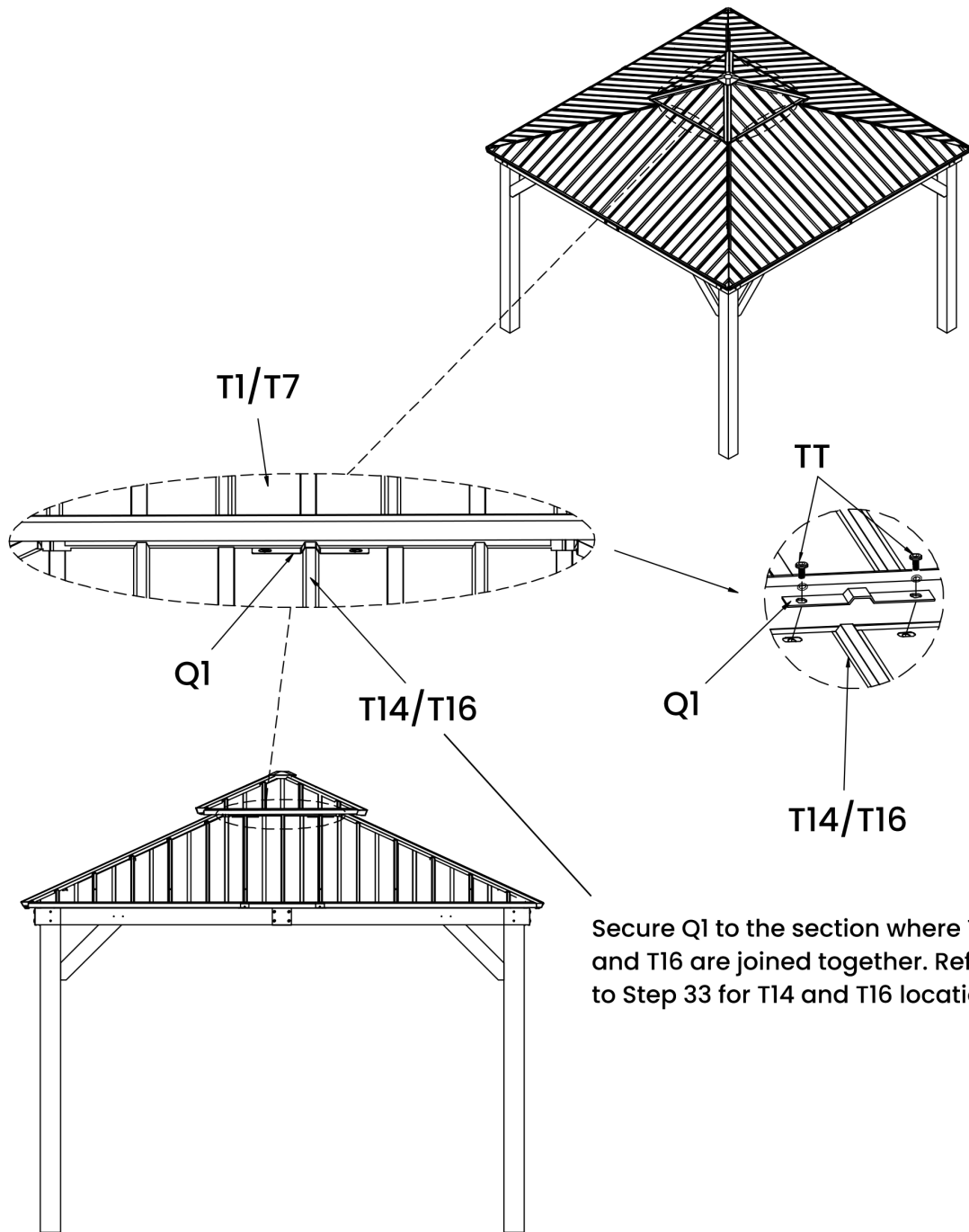

Q1 4pcs



M6X15

TT 8pcs

**STEP 35**

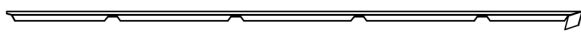
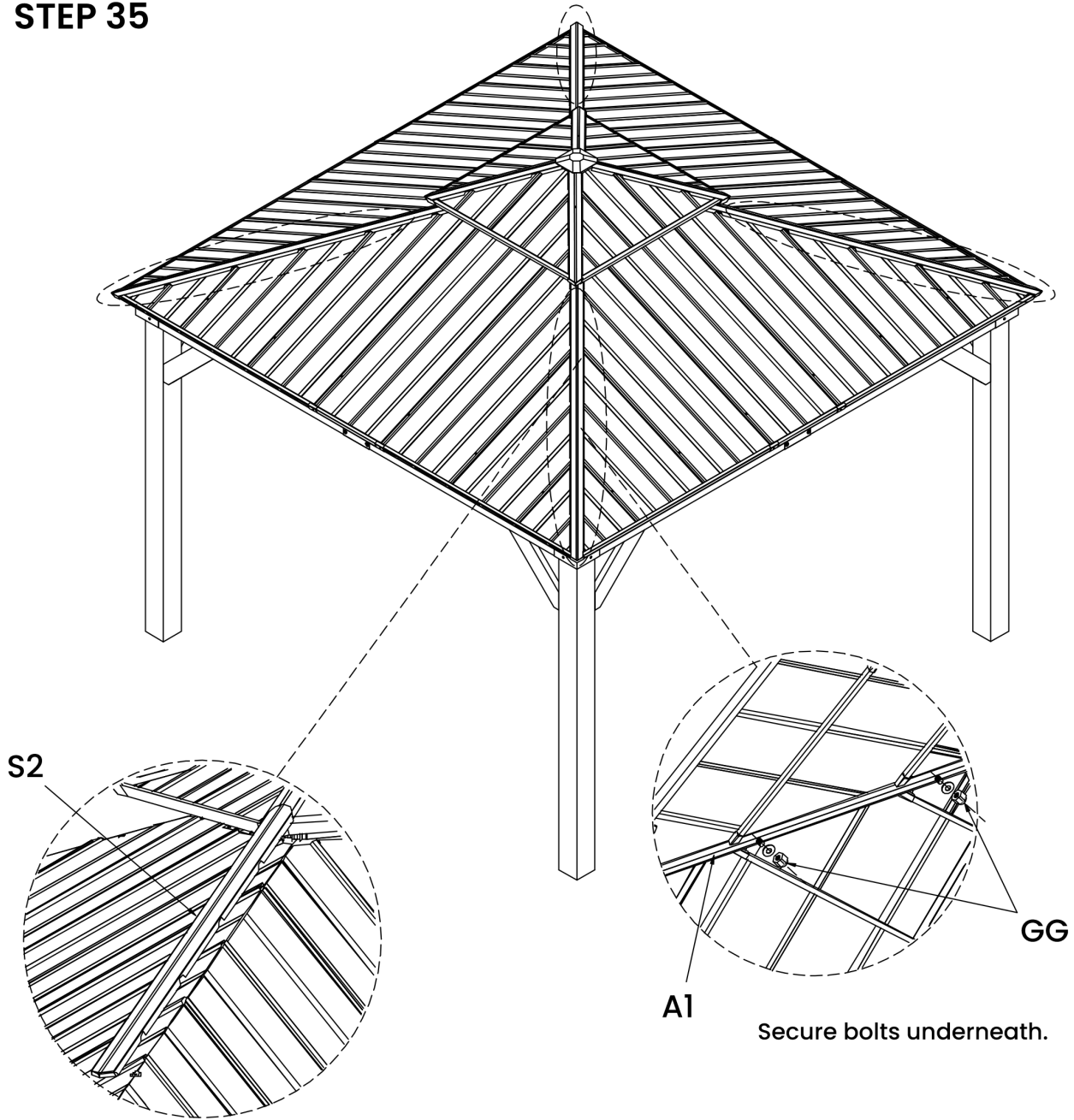

**S2** 4pcs



**GG** 8pcs

# STEP 36

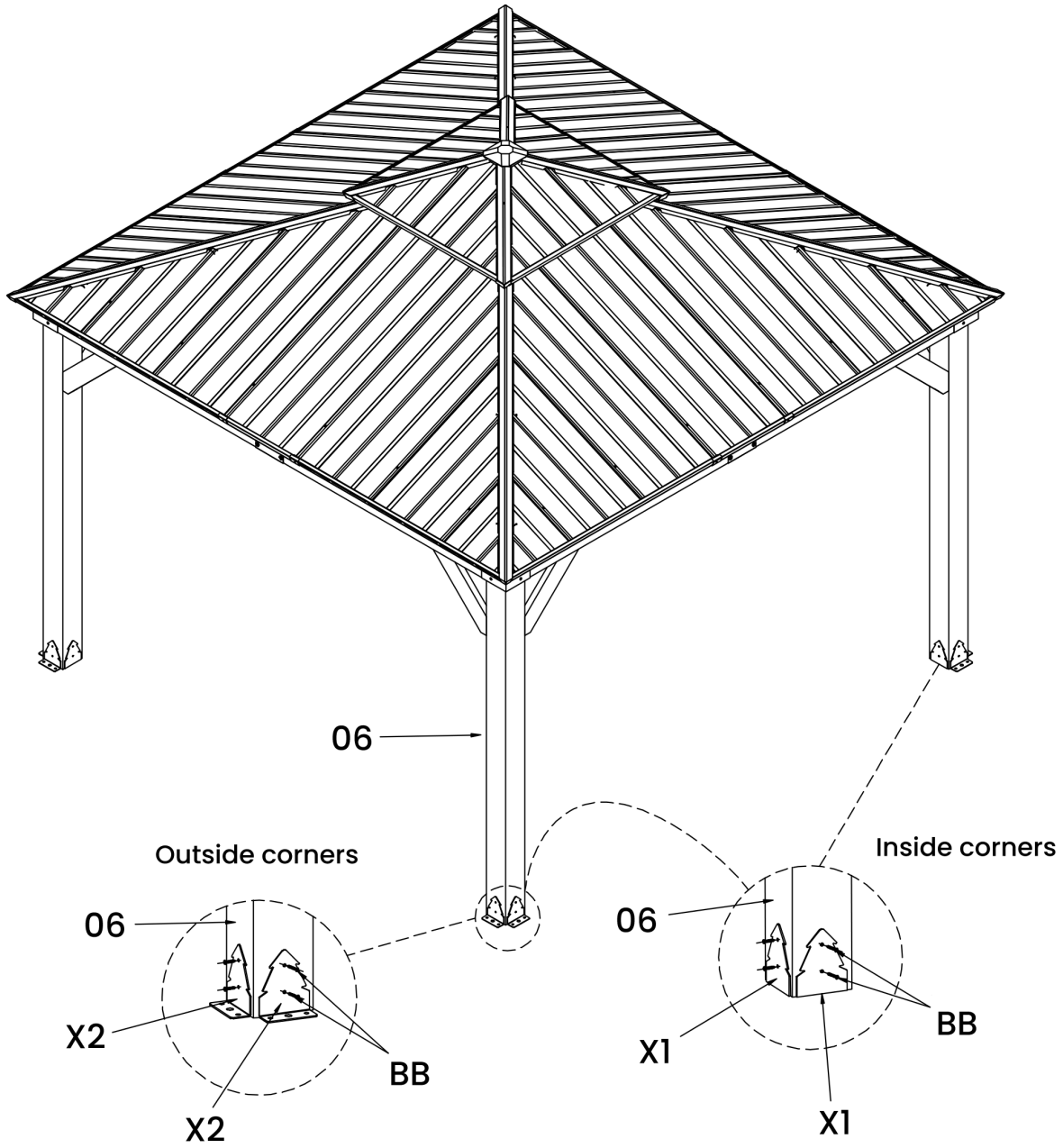

(X1) 8pcs



(X2) 8pcs



(BB) 32pcs

M5X30

## STEP 37

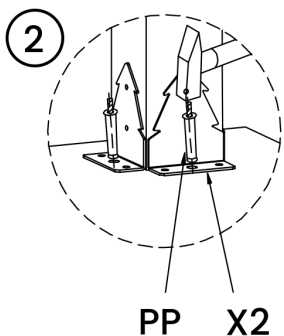
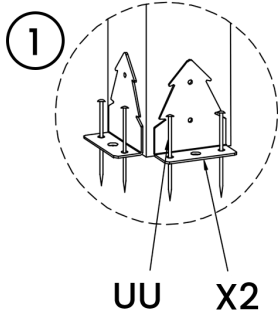
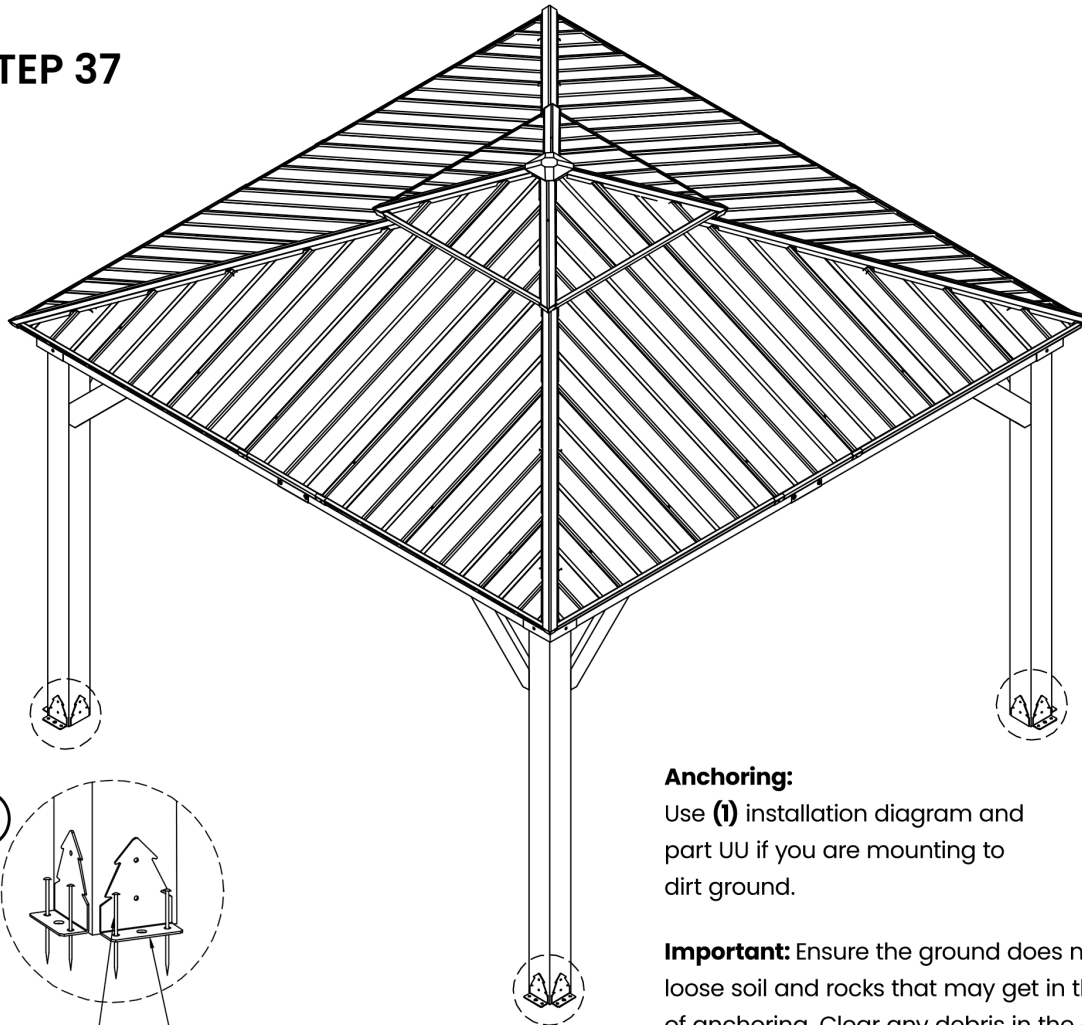

### Anchoring:

Use **(1)** installation diagram and part UU if you are mounting to dirt ground.

**Important:** Ensure the ground does not have loose soil and rocks that may get in the way of anchoring. Clear any debris in the area.

### Instructions:

1. Hammer the stakes directly into the ground.

Use **(2)** installation diagram and part PP if you are mounting on a concrete base.

**Important:** Ensure the concrete surface where you intend to install the wedge anchors is safe and can support the objects you plan to fasten. Clear any debris in the area.

### Instructions:

1. First mark your area then drill a hole into the concrete. The bit should be the same diameter as part PP. Ensure the depth of the hole is about a 1/2" deeper than the length of part PP.

2. Remove the dust and debris from the drill holes using brush or vacuum.  
3. Insert anchor PP into the holes and tap with hammer to set it firmly in the hole.

4. Tighten the nut and washer onto the exposed thread end of the anchor. Use a wrench or socket set to tighten the nut until it's snug. Be careful not to over-tighten, as this could damage the anchor or the concrete.

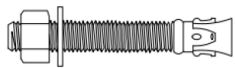

**PP** 8pcs



**UU** 16pcs

---

## VI. WOOD ADVICE

Lifespan Kids uses 100% cedar wood. While we carefully select the highest quality lumber available, wood is a natural product and may be susceptible to weathering, which can affect the appearance of your set.

### What Causes Weathering? Does It Affect the Strength of My Product?

One of the primary causes of weathering is the effect of moisture. The moisture content at the surface of the wood differs from that of the interior. As climate conditions change, moisture moves in or out of the wood, causing tension that can result in checking or warping. You can expect the following due to weathering, though these changes will not affect the strength of the product:

1. **Checking** refers to surface cracks in the wood along the grain. A post (4" x 4") is more prone to checking than a board (1" x 4") because there is a greater difference in moisture content between the surface and the interior of thicker wood.
2. **Warping** results from distortions (twisting, cupping) in the original shape of the board and typically occurs from rapid cycles of wetting and drying.
3. **Fading** is a natural process where the wood colour changes due to sun exposure, gradually turning grey over time.

### How Can I Reduce Weathering on My Wood Product?

1. Your wood product is coated with a water-based stain, but sunlight will degrade this coating over time. We recommend applying a water repellent or stain annually (consult your local stain and paint supplier for recommended products). It is essential to apply some form of protection (sealant) to the wood. This is a **requirement of your warranty**. Most weathering is a normal consequence of nature and does not affect safety. However, if you believe a part has experienced severe weathering, please contact our customer service department for further assistance.
2. **Inspect wood parts monthly**. During dry seasons, the grain may lift, causing splinters. Light sanding may be necessary to ensure safety. After sanding, applying a protective sealant will help prevent severe checking, splitting, and other weather-related damage.

### When should wood cracks be a concern?

Most of the wood splits will never become large enough to affect the reliability and strength of our products, however, there can be rare cases where splits can occur. This happens when a crack develops past the halfway point from the timber, splitting it into two separate pieces. Feel free to contact us with detailed pictures of your product so we can assess and ensure that your playground remains safe.

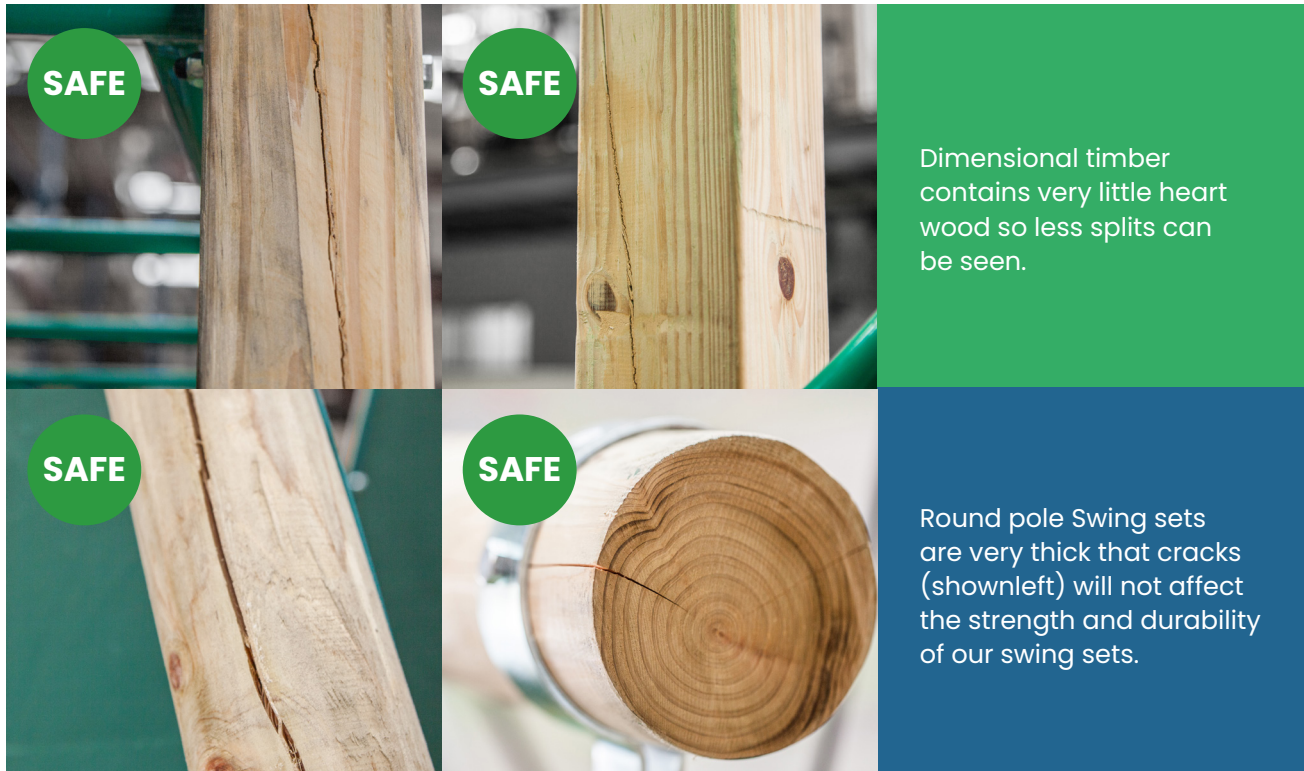

Dimensional timber contains very little heart wood so less splits can be seen.

Round pole Swing sets are very thick that cracks (shown left) will not affect the strength and durability of our swing sets.

### **Mould and Mildew**

Protecting against mould and mildew on your outdoor equipment is an important step in maintaining your backyard. Mould may develop for several reasons, such as certain weather conditions, improper drainage or infrequent usage. Here we'll share our tips for keeping your outdoor areas free of mould and mildew so that you can enjoy your backyard with peace of mind.

Once you spot mould on your equipment, it's important to start clearing it up straight away. The first step is to scrub it off with soap and water, until all the visible signs of mould are removed. It's important to remember however, that just because you can't see it anymore doesn't mean it's gone.

The next step is to kill off the remaining mould so that it doesn't grow back. Here are a few options, but keep in mind these should be used independently. Don't mix or combine these methods at the same time.

#### **Mould Killer or Removal Spray**

You can purchase off-the-shelf removal sprays that destroy mould either indoors or outdoors. For these products, make sure to follow the product instructions as well as wearing protective gloves to avoid contact with skin.

---

## VII. CLEANING

Do not use any abrasive cleansers for the cleaning. Use a soft, damp cloth to eliminate dirt and dust.

---

## VIII. WARRANTY

### AUSTRALIAN CONSUMER LAW

Many of our products come with a guarantee or warranty from the manufacturer. In addition, they come with guarantees that cannot be excluded under the Australian Consumer Law. You are entitled to a replacement or refund for a major failure and compensation for any other reasonably foreseeable loss or damage.

You are entitled to have the goods repaired or replaced if the goods fail to be of acceptable quality and the failure does not amount to a major failure. Full details of your consumer rights may be found at [www.consumerlaw.gov.au](http://www.consumerlaw.gov.au).

Please visit our website to view our full warranty terms and conditions:  
[www.lifespankids.com.au/Warranty-Policy-Kids](http://www.lifespankids.com.au/Warranty-Policy-Kids)

### WARRANTY AND SUPPORT

Please email us at [support@lifespankids.com.au](mailto:support@lifespankids.com.au) for all warranty or support issues.

For all warranty or support related enquiries, please lodge a support ticket first by sending us an email.  
[support@lifespankids.com.au](mailto:support@lifespankids.com.au).









