

QUANTUM 2 INVERSION TABLE OWNER'S MANUAL

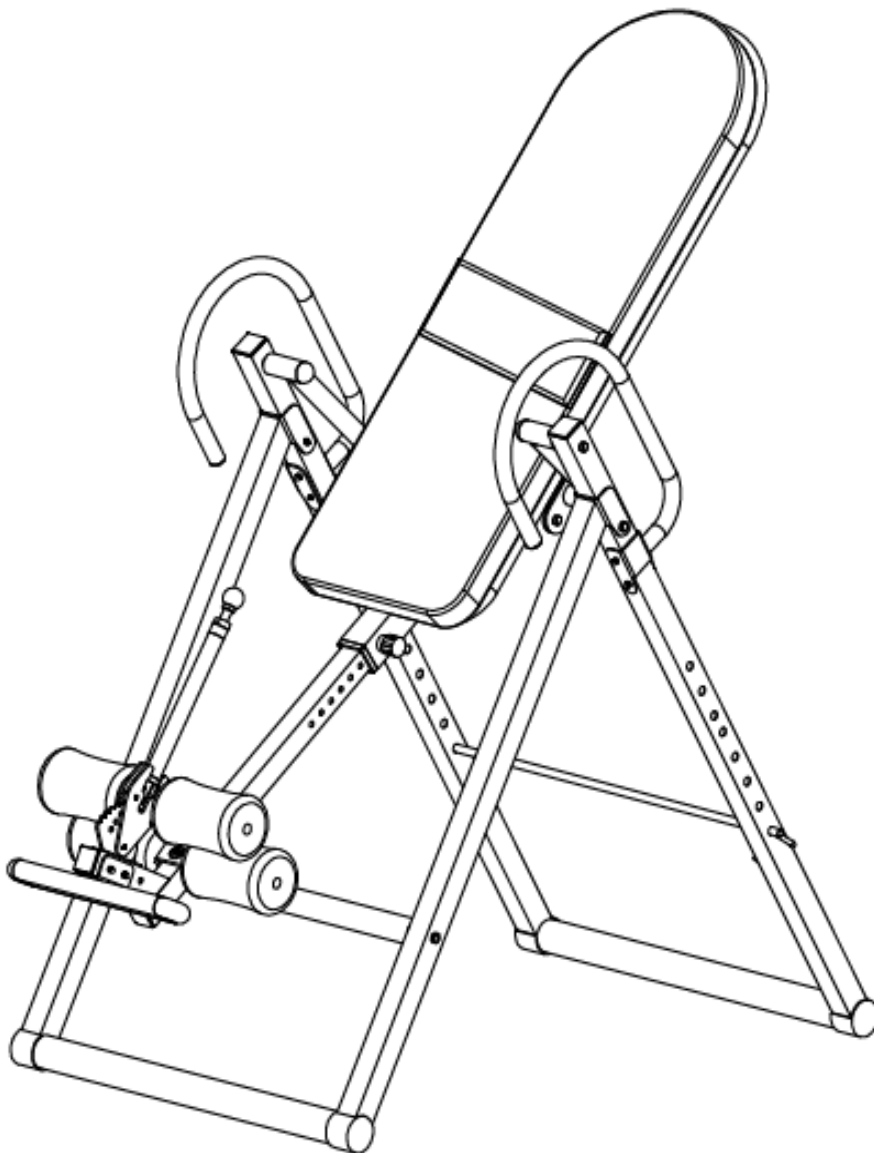

Product may vary slightly from the item pictured due to model upgrades

Read all instructions carefully before using this product. Retain this owner's manual for future reference.

TABLE OF CONTENTS

1.	IMPORTANT SAFETY INSTRUCTIONS	3
2.	CARE INSTRUCTIONS	4
3.	EXPLODED DIAGRAM	5
4.	PARTS LIST	6
5.	ASSEMBLY INSTRUCTIONS	7
6.	WARRANTY	12
7.	WARRANTY	13

1. IMPORTANT SAFETY INSTRUCTIONS

WARNING - Read all instructions before using this machine.

It is important your machine receives regular maintenance to prolong its useful life. Failing to regularly maintain your machine may void your warranty.

Please keep this manual with you at all times

- a. It is important to read this entire manual before assembling and using the equipment. Safe and effective use can only be achieved if the equipment is assembled, maintained and used properly. Please note: It is your responsibility to ensure that all users of the equipment are informed of all warnings and precautions.
- b. Before starting any exercise program you should consult your doctor to determine if you have any medical or physical conditions that could put your health and safety at risk, or prevent you from using the equipment properly. Your doctor's advice is essential if you are taking medication that affects your heart rate, blood pressure or cholesterol level.
- c. Be aware of your body's signals. Incorrect or excessive exercise can damage your health. Stop exercising if you experience any of the following symptoms: pain, tightness in your chest, irregular heartbeat, and extreme shortness of breath, lightheadedness, dizziness or feelings of nausea. If you do experience any of these symptoms, you should consult your doctor before continuing with your exercise program.
- d. Keep children and pets away from the equipment. This equipment is designed for adult use only.
- e. Use the equipment on a solid, flat level surface with a protective cover for your floor or carpet. To ensure safety, the equipment should have at least 2 meters of free space around it.
- f. Before using the equipment, check that the nuts and bolts are securely tightened. If you hear any unusual noises coming from the equipment during use and assembly, stop immediately. Do not use the equipment until the problem has been rectified.
- g. Wear suitable clothing while using the equipment. Avoid wearing loose clothing that may get caught in the equipment or that may restrict or prevent movement.

- h. This equipment is designed for indoor and family use only
- i. Care must be taken when lifting or moving the equipment so as not to injure your back.
- j. Always keep this instruction manual and assembly tools at hand for reference.
- k. The equipment is not suitable for therapeutic use.







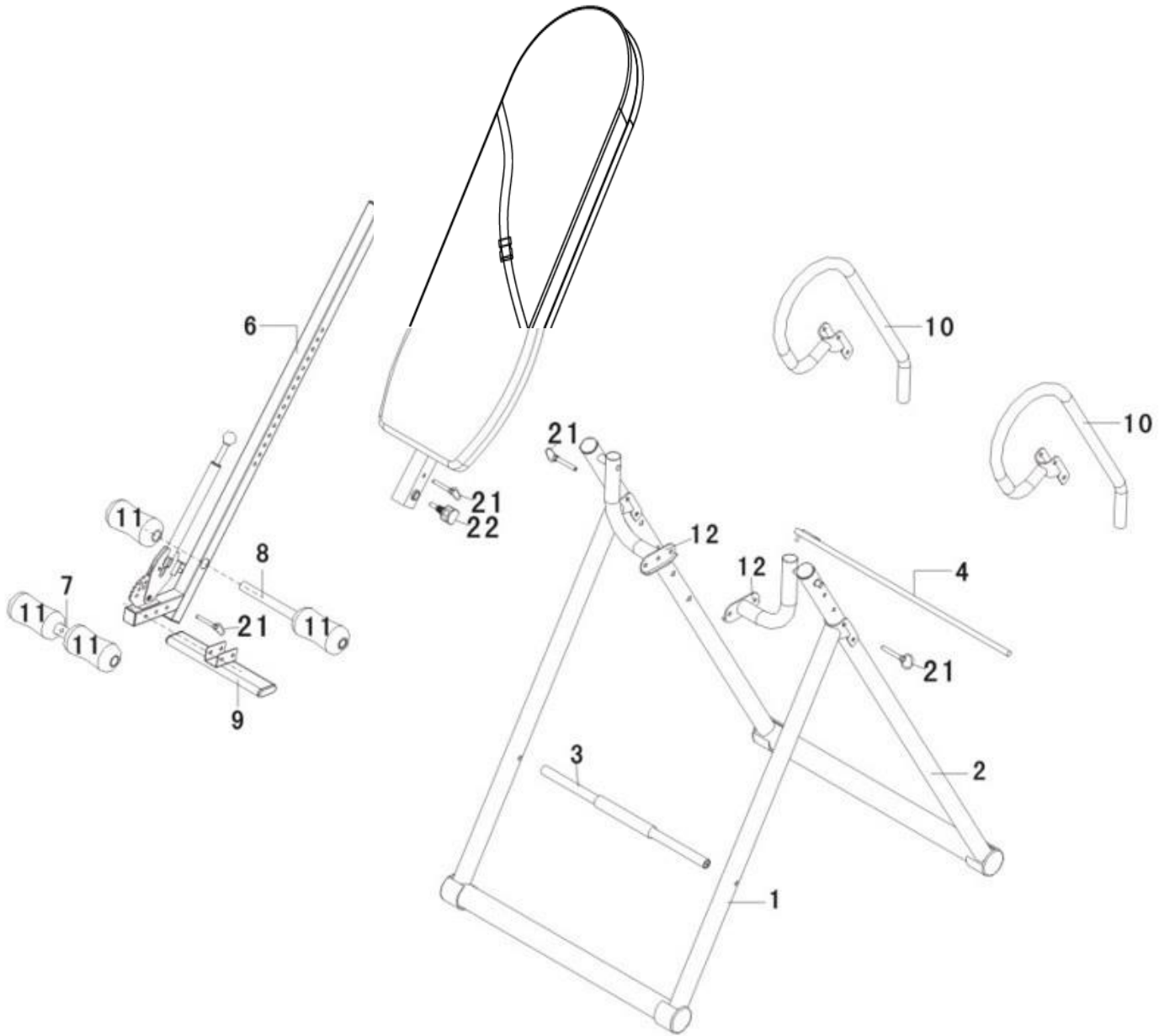





2. CARE INSTRUCTIONS

- a. Lubricate moving joints with grease after periods of usage
- b. Be careful not to damage plastic or metal parts of the machine with heavy or sharp objects
- c. The machine can be kept clean by wiping it down using dry cloth

3. EXPLODED DIAGRAM



4. PARTS LIST

NO.	Name	Qty.	NO.	Name	Image	Specification	Qty.
1	Front leg bracket	1	14	Hex screw		M8x55	4
2	Back leg bracket	1	15	Washer		Φ8.5*Φ16*1.2	8
3	Front support bar	1	16	Hex screw		M8X20	4
4	Back support bar	1	17	Nut		M12 attached in part12 already	1
5	Back rest frame	1	18	Nut		M8	8
6	Height adjusting pipe	1	19	Washer		Φ10.5*Φ20*1.2	1
7	Front foot lock pipe	1	20	Cross flat head screw		M6x16	6
8	Back foot lock pipe	1	21	Pin with draw ring		Φ8x55	4
9	Foot Plate	1	22	Draw pin		M16x20	1
10	Left and Right Handrail	1	23	Wrench		13#-15#	1
11	Foam	4	24	Wrench		14#-17#	1
12	Z type bracket	2	25	Allen key		5# Cross	1
13	Head rest	1					

5. ASSEMBLY INSTRUCTIONS

STEP 1:

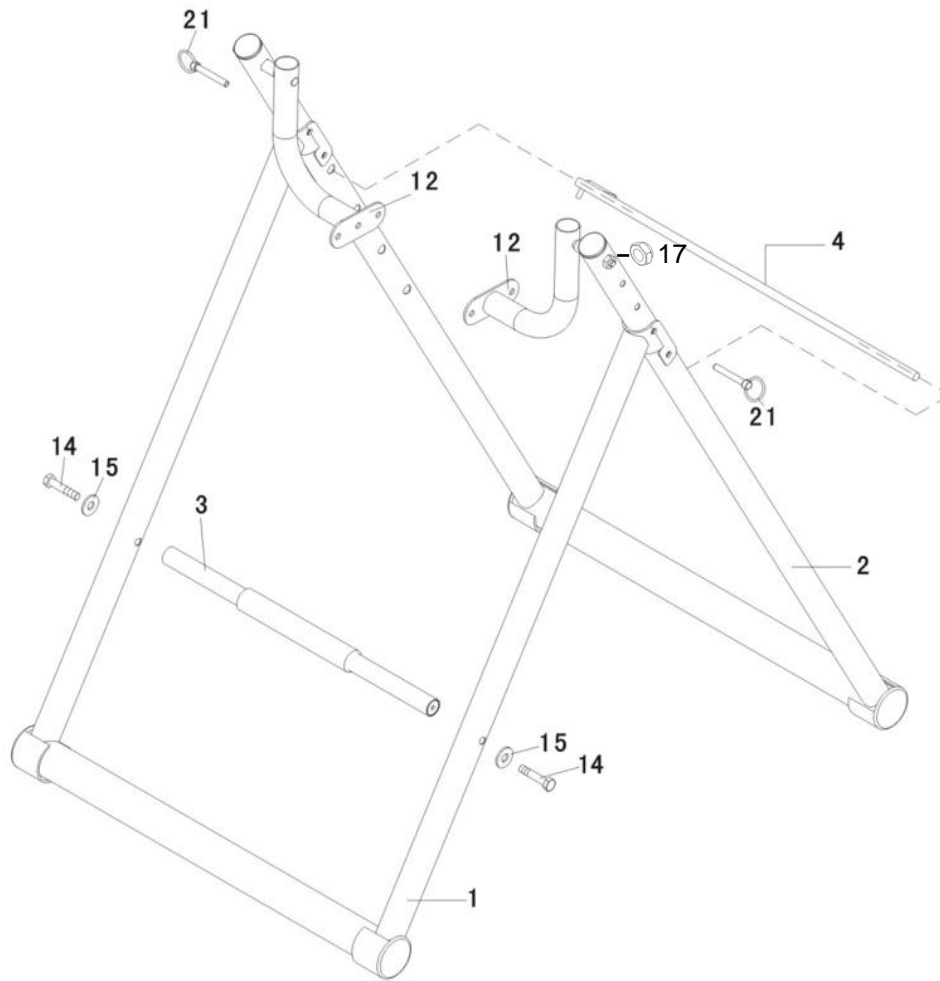

- a. Use the 2x Hex Screw (14) and 2x Washer (15) to secure the Front support bar (3) onto the Front leg bracket (1).
- b. To adjust your decline angle, insert the Back support bar (4) into the Back leg bracket (2) and secure Front and back leg bracket with 1x Pin with draw ring (21).
- c. Attach the z bracket(12) to rear support tube(2) with nut M12 (17)

STEP 2:

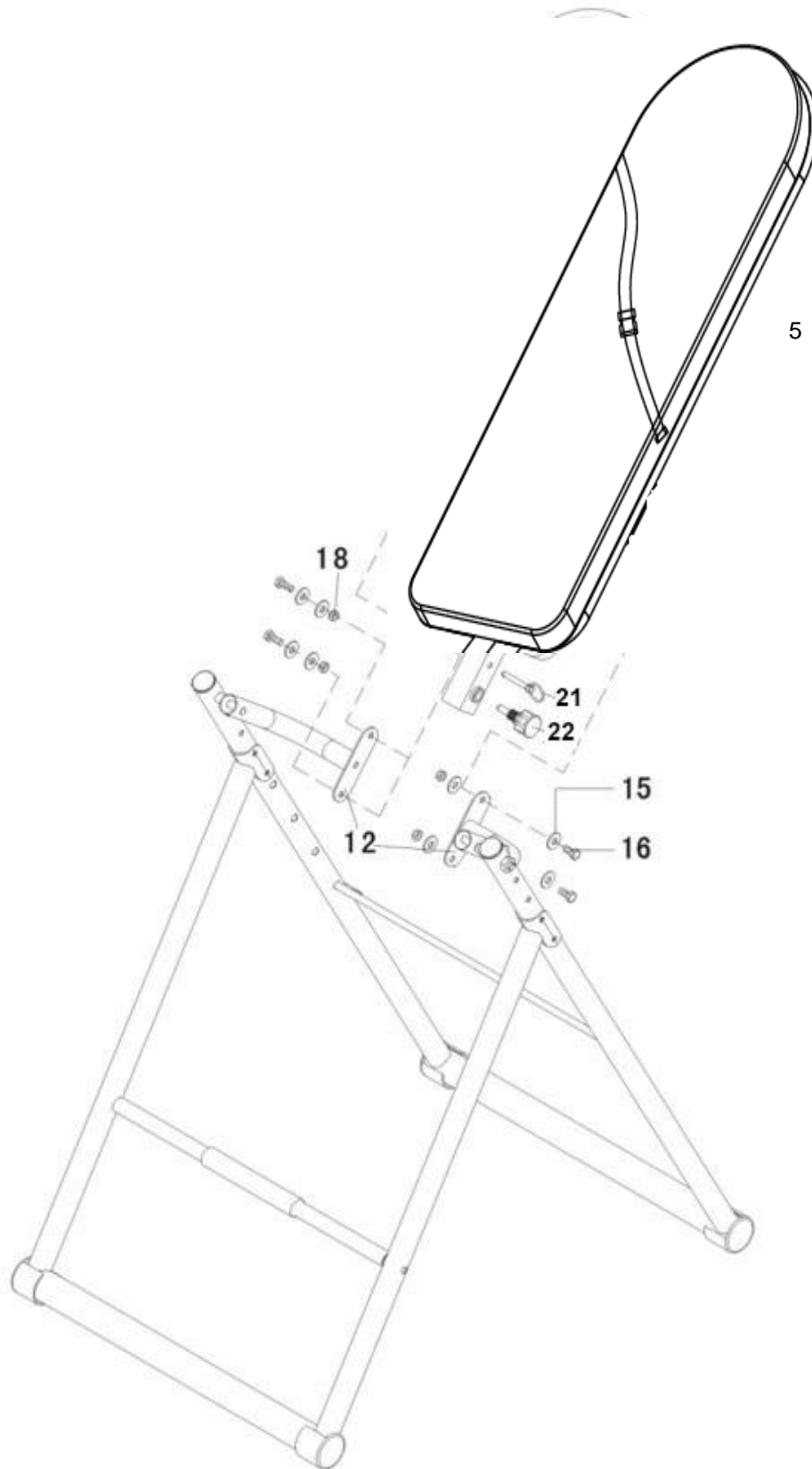

Use 4x Hex screw (16), 4x Washer (15) and 4x Nut (18) to secure part (5) to part (12).

STEP 3:

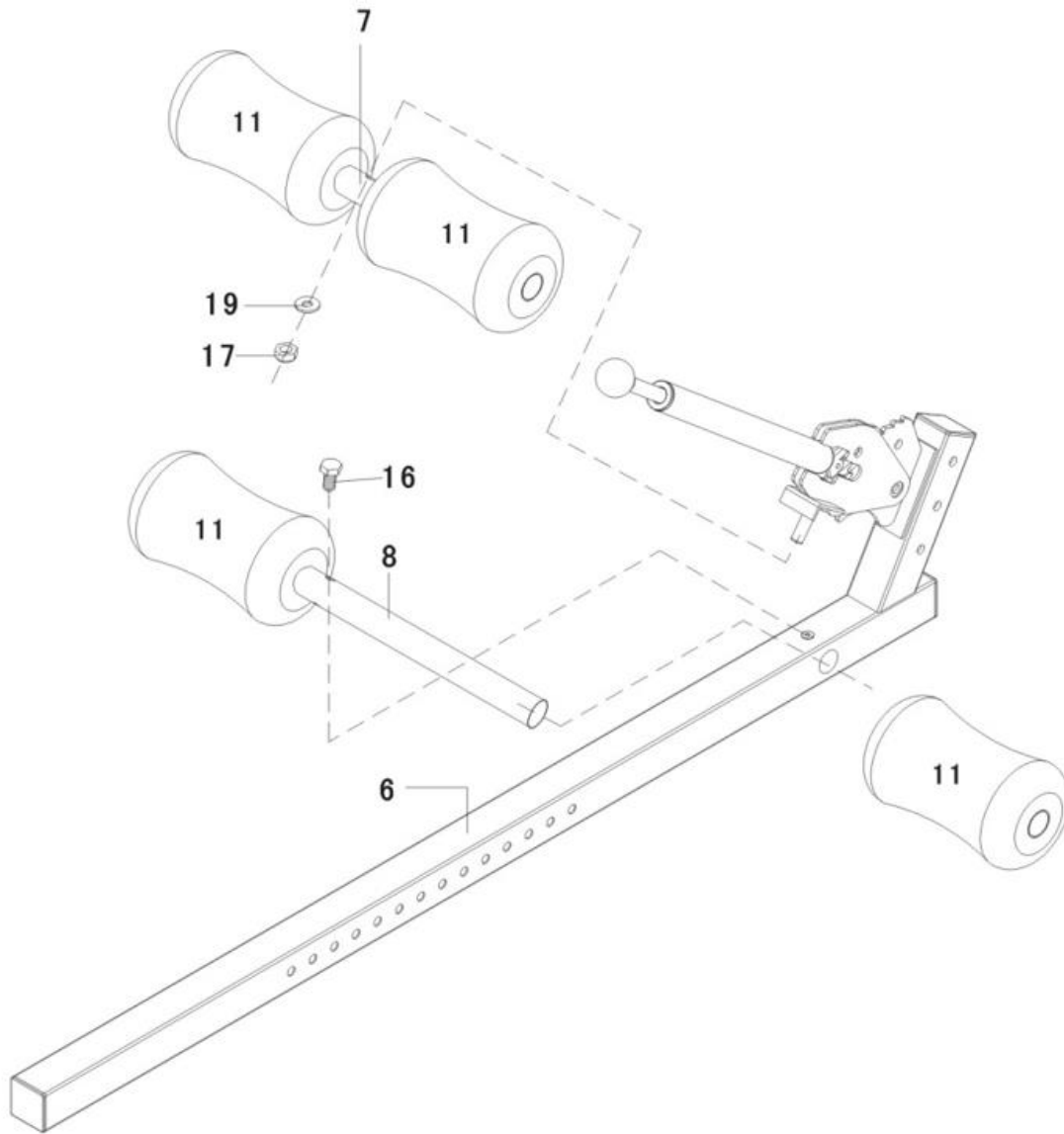

- a. Insert the Back foot lock pipe (8) into the Height adjusting pipe (6) and secure with 1x Hex screw (16).
- b. Attach the Foam (11) onto part (8).
- c. Secure Front foot lock pipe (7) to the foot locking lever (as pictured), using 1x Washer (19) and 1x Nut (17).

STEP 4:

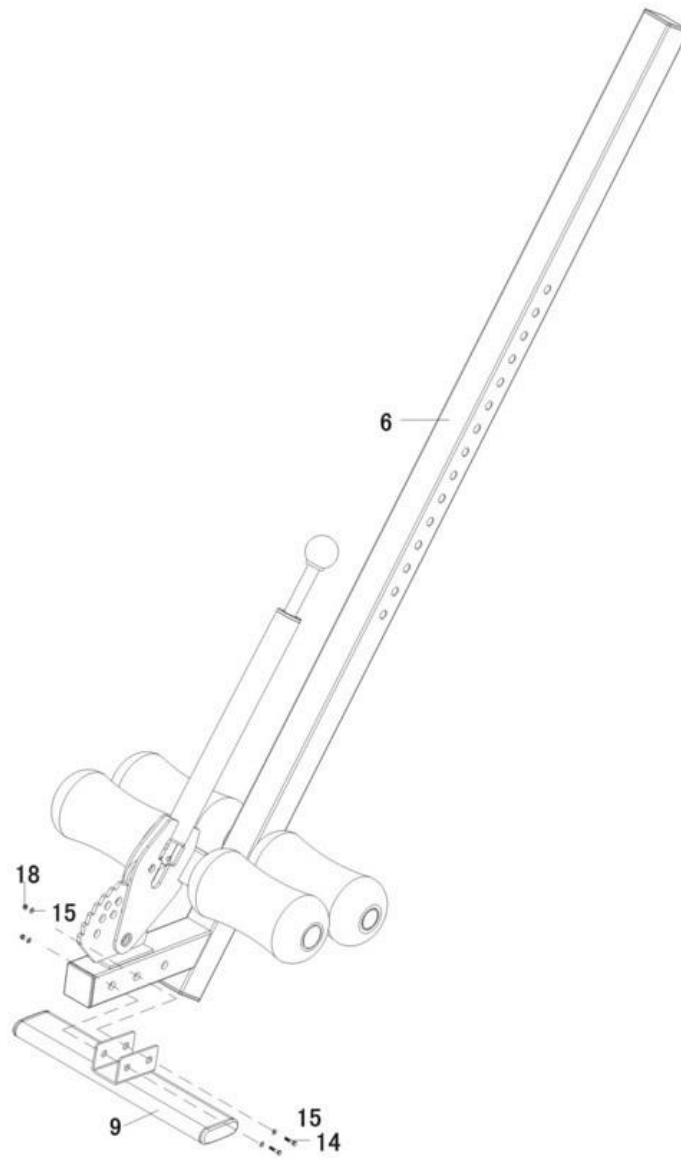

- a. Secure part (6) to Foot Plate (9) with 2x Hex screw (14), 4x Washer (15) and 2x Nut (18).

STEP 5:

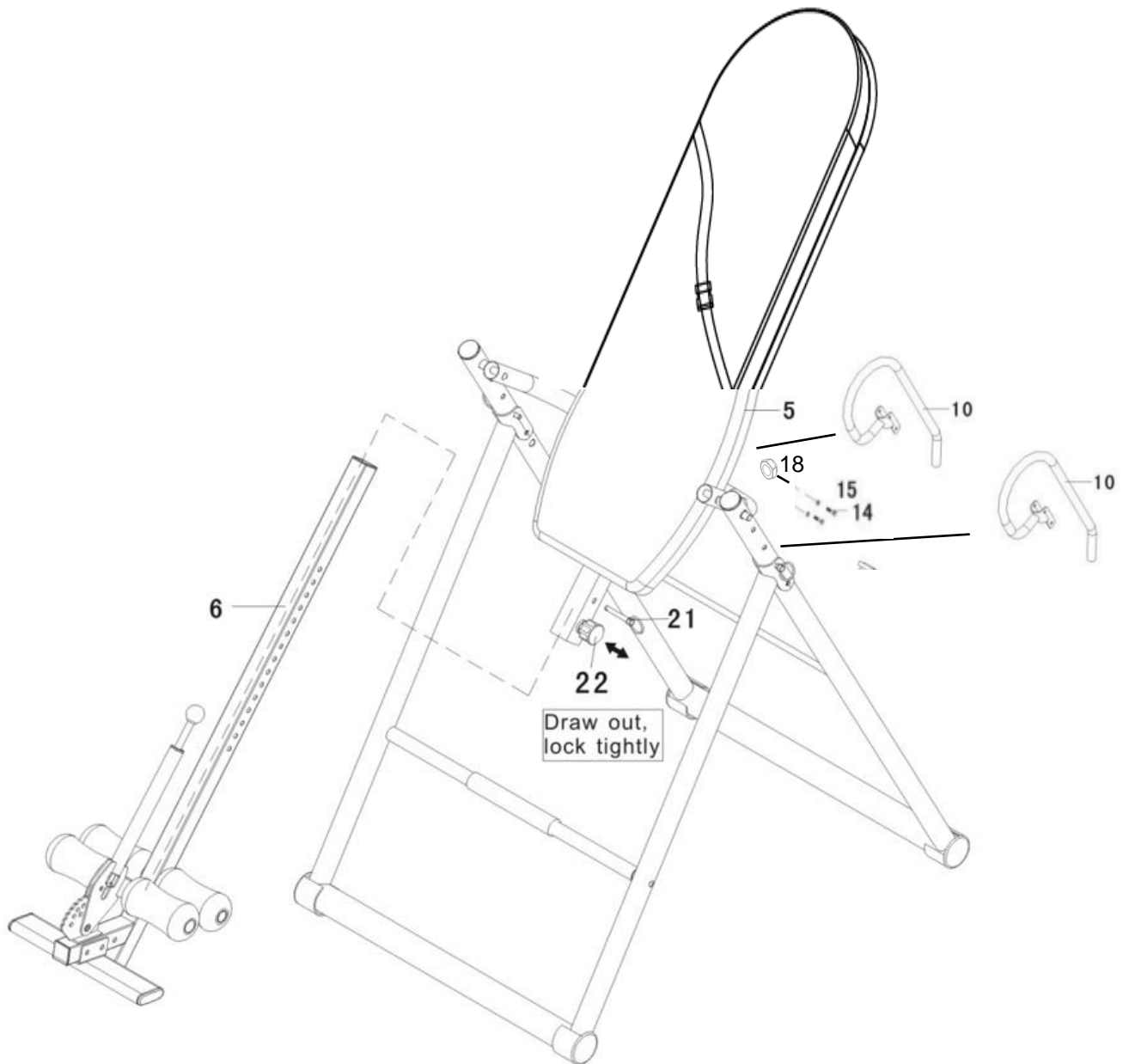

- a. Insert Height adjusting pipe (6) into the Back rest frame (5).
- b. Secure with Drawing pin (22) and Draw pin with ring (21) into part (6) at the required height of user. Tighten the pin.
- c. Lock the handlebar (10L/R) onto the rear leg bracket with bolt (14), flat washer (15) and nut (18).

6. INSTRUCTION GUIDE

1

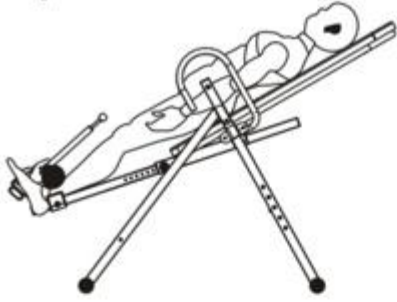

3



2

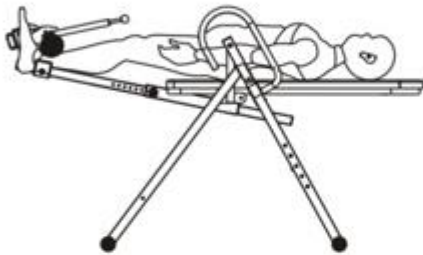

4

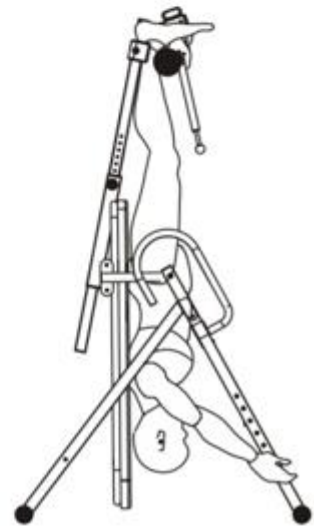
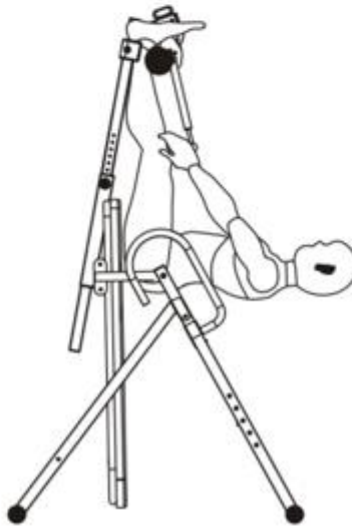
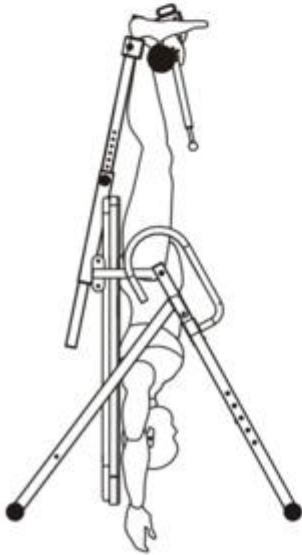
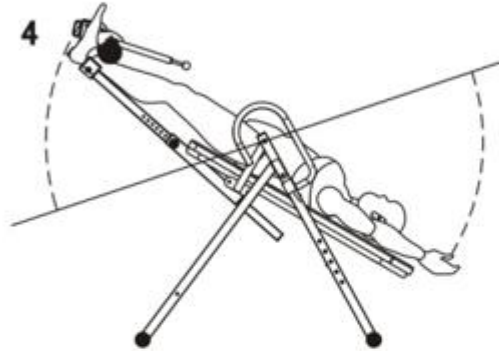

7. WARRANTY

AUSTRALIAN CONSUMER LAW

Many of our products come with a guarantee or warranty from the manufacturer. In addition, they come with guarantees that cannot be excluded under the Australian Consumer Law. You are entitled to a replacement or refund for a major failure and compensation for any other reasonably foreseeable loss or damage.

You are entitled to have the goods repaired or replaced if the goods fail to be of acceptable quality and the failure does not amount to a major failure. Full details of your consumer rights may be found at www.consumerlaw.gov.au

Please visit our website to view our full warranty terms and conditions:

<http://www.lifespanfitness.com.au/warranty-repairs>

Warranty and Support:

Please email us at support@lifespanfitness.com.au for all warranty or support issues.

For all warranty or support related enquiries an email must be sent before contacting us via other means.

Head Office and Customer Service:

Global Fitness and Leisure Pty Ltd
17 Fordson Rd
Campbellfield
VIC, 3061
Australia
PH: 03 9357 2166