

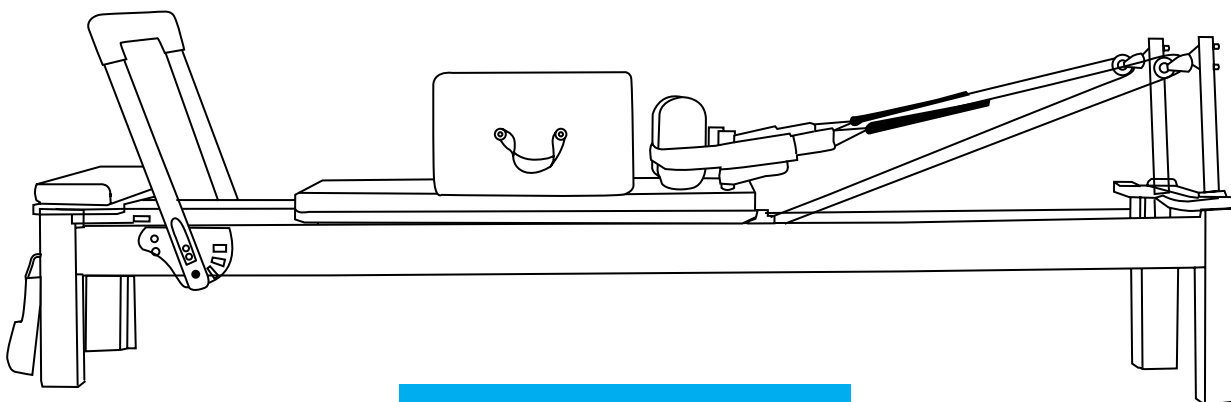

Contour Pro Studio Aluminium Reformer Pilates Bed Set

USER MANUAL

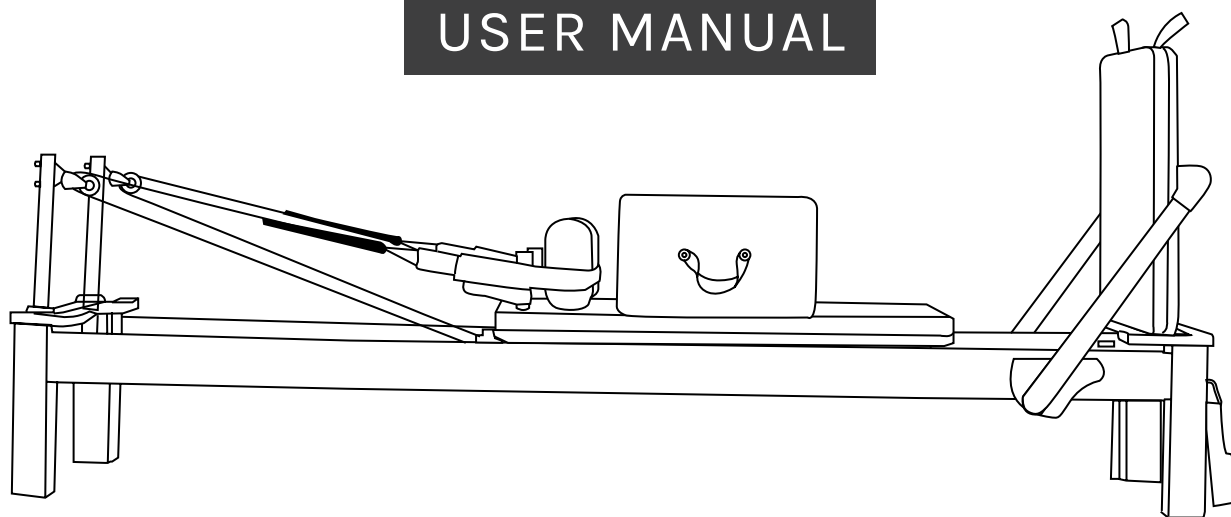

Find the
Digital Manual
Online



**Read all instructions carefully before using this product.
Retain this owner's manual for future reference.**



IMPORTANT

This manual contains important assembly, safety and warranty information. Read the manual carefully before using your new equipment and keep the manual on hand for future reference.

UNSAFE OR IMPROPER USE OF THIS EQUIPMENT BY FAILING TO READ AND COMPLY WITH ALL REQUIREMENTS AND WARNINGS COULD RESULT IN SERIOUS INJURY.



TABLE OF CONTENTS

- I. Important Safety Instructions 03
- II. Parts List 05
- III. Assembly Instructions 06
- IV. Exercise Guide 16
- V. Warranty 18

I. IMPORTANT SAFETY INSTRUCTIONS

The proper utilization of Pilates equipment can enhance the execution of numerous Pilates exercises in a secure and efficient manner. Nevertheless, it is crucial to exercise care and caution due to the potential risks associated with exercise equipment, particularly when spring resistance is involved.

If you lack experience or are using this equipment for the first time, it is essential to have a trained professional supervise your usage. It is important to ensure that both you and your clients/patients have received adequate instruction on the appropriate and safe utilization of this equipment.

Equipment Safety Instructions:

1. Ensure the equipment is placed on a stable and level surface.
2. For optimal performance, allow at least 1m of clear space on either side of the Reformer.
3. Assemble the equipment following the manufacturer's instructions and make sure all parts are securely fastened.
4. Regularly inspect the equipment for any loose or damaged components. Do not use if any parts are broken or malfunctioning.
5. Be careful of fingers from folding/unfolding and moving the carriage.

User Precautions:

1. Consult a qualified healthcare professional before starting any new exercise program, especially if you have any medical conditions, injuries, or are pregnant.
2. Wear comfortable workout attire that allows for freedom of movement.
3. Keep body, clothing and hair free from all moving parts.
4. Remove any jewellery, watches, or accessories that could interfere with your workout or damage the equipment.
5. Start with a warm-up to prepare your body for exercise. Perform gentle stretches and mobilization exercises.
6. Familiarize yourself with the various parts of the reformer equipment, including the foot bar, carriage, straps, and springs.
7. Maintain proper form and alignment throughout your workout. Engage your core and keep your spine neutral.
8. Breathe naturally and avoid holding your breath during exercises.
9. Perform exercises within your comfortable range of motion. Avoid excessive or jerky movements that may cause injury.
10. Stop exercising if you feel pain, dizziness, or discomfort. Listen to your body and rest as needed.
11. This equipment is to be used by one person at a time. Do not allow children to use or be around equipment without adult supervision.

Equipment Usage:

1. Adjust the equipment settings, such as foot bar height and spring tension, according to your instructor's guidance and your fitness level.
2. Always check that the springs and straps are in good condition and securely attached before use.
3. Do not sit on carriage while adjusting levels.
4. Take care when attaching and detaching springs.
5. Place your hands and feet in the designated areas on the carriage and foot bar while performing exercises.
6. Use proper grip and control during exercises to ensure stability and avoid slipping.
7. Avoid sudden movements or excessive force that may cause the carriage to move uncontrollably.
8. Be mindful of the equipment's weight limit and do not exceed it.

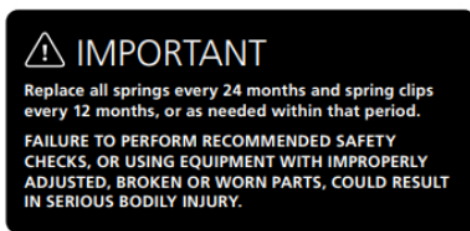

Cleaning and Maintenance:

1. Clean the equipment regularly with a mild, non-abrasive cleanser and a soft cloth.
2. Inspect the equipment for any signs of wear or damage for example, springs, ropes and rollers. Do not use if parts are damaged.
3. All hardware should be checked every 2 months to make sure that every nut, bolt and fastener is secure. If, at any time, a component exhibits free play, its hardware needs to be properly re-tightened immediately.
4. Lubricate moving parts, such as wheels or springs, as recommended by the manufacturer.
5. Store the equipment in a dry and clean area when not in use.
6. Any spring that exhibits early signs of fatigue (for example, separation in coils) need to be replaced immediately. High-use facilities should replace springs more often.
7. Over time you may experience some minor "fraying" in the ropes. Fraying is completely normal and to be expected. Any ropes with excess fraying, tearing or other problems need to be replaced immediately.

II. PARTS LIST

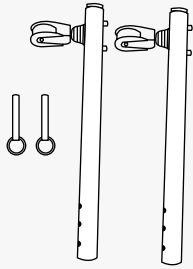

Risers (2x) and Pin (2x)

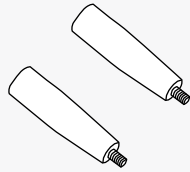

Handle (2x)

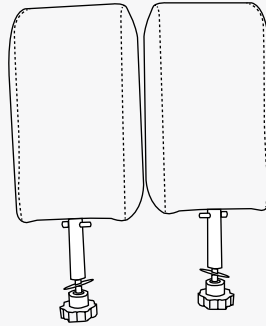

Shoulder Rest Block Set (2x)



Rope (1x)

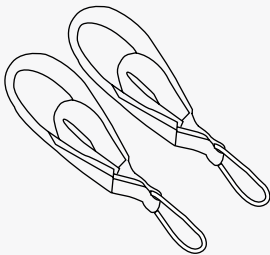

Feet/handle Strap (2x)

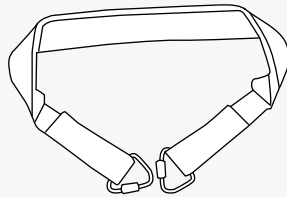

Foot Strap Attachment

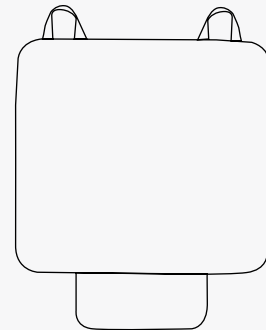

Jump Board (1x)

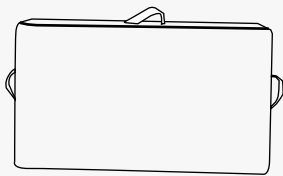

Box (1x)



Foot Platform
(1x, pre-assembled)

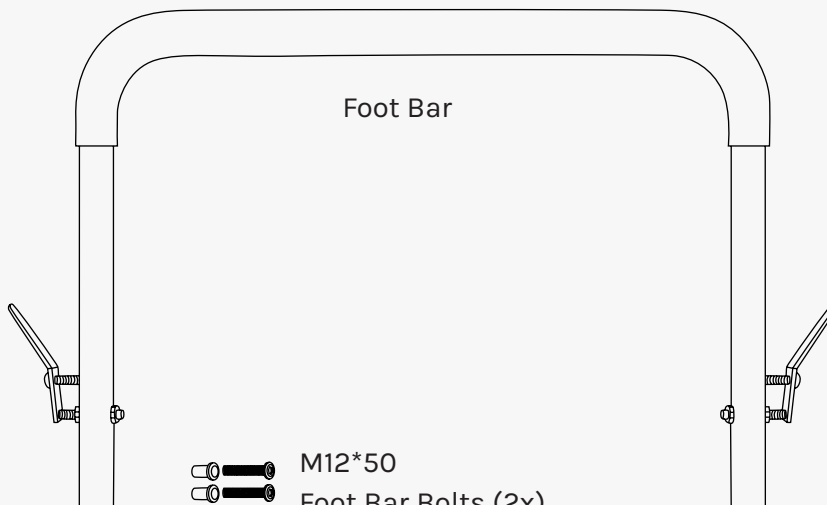

Foot Bar

M12*50
Foot Bar Bolts (2x)

III. ASSEMBLY INSTRUCTIONS

UNPACK THE CARTON

! WARNING

Since no springs are attached, the carriage is not locked in position and may start to roll, be extra cautious when moving the unit.

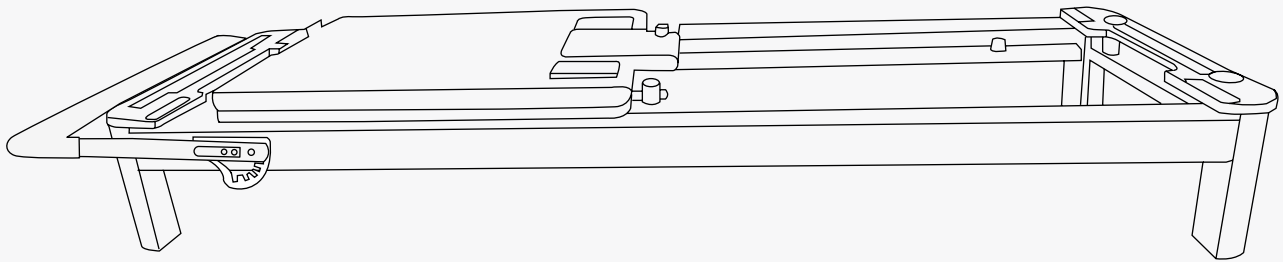

1. Remove the parts out of the carton. Ensure you have enough space for assembly.

! CAUTION: You may need 2 people to lift the frame out of box.

ASSEMBLY THE RISERS

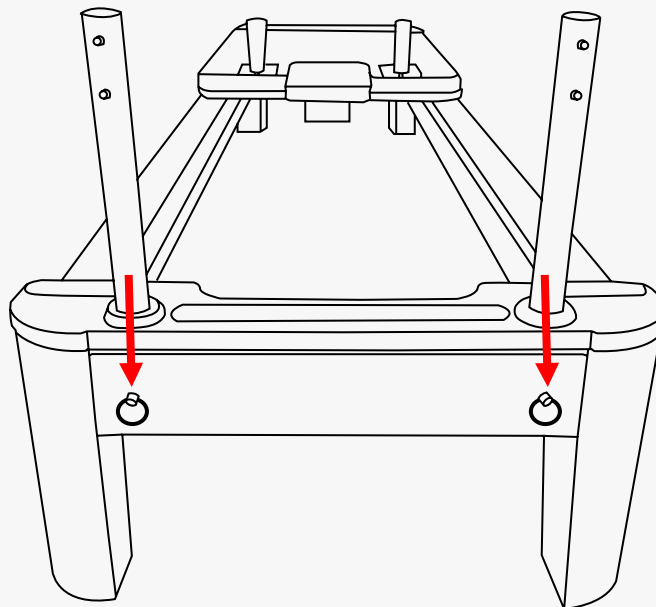

1. Insert the Riser into the respective spots and slot in the pin for your preferred height.

ASSEMBLE THE HANDLE

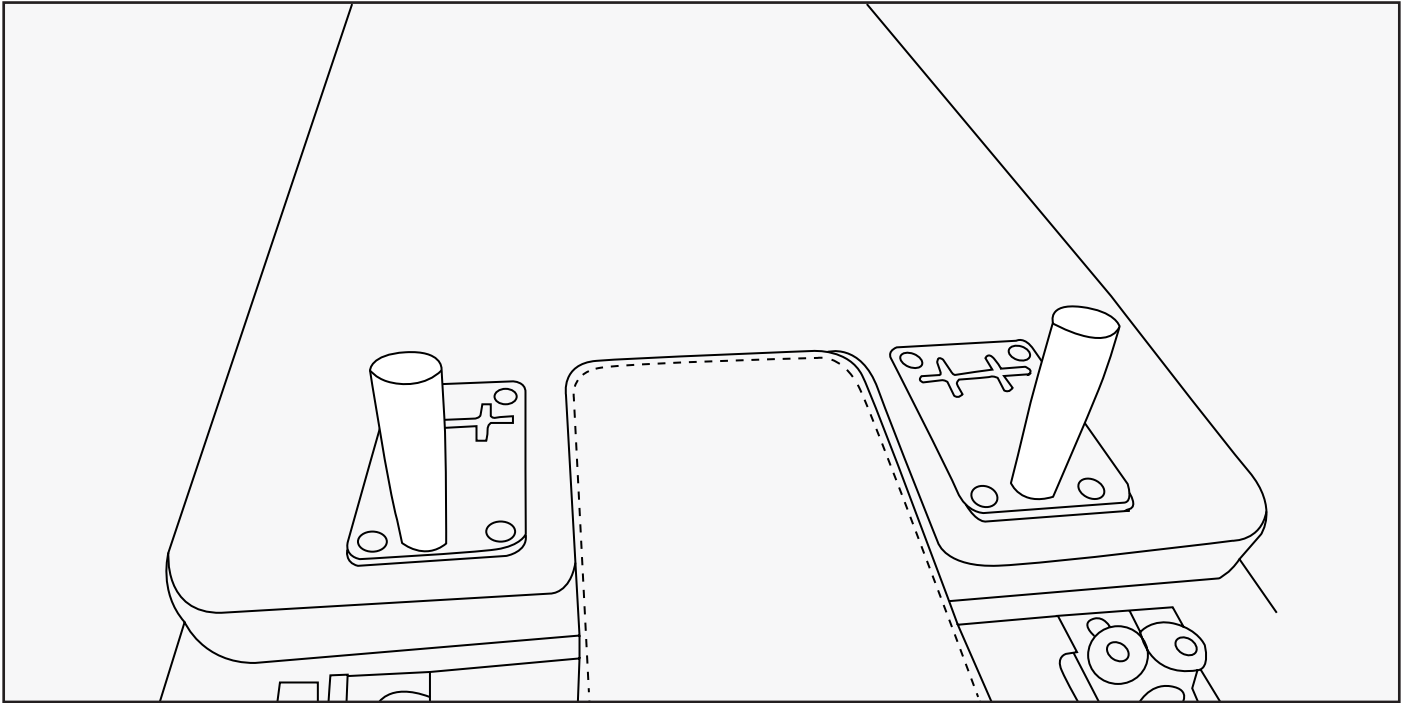

1. Screw in the handles to the Carriage near the head rest.

ASSEMBLE THE SHOULDER REST BLOCKS

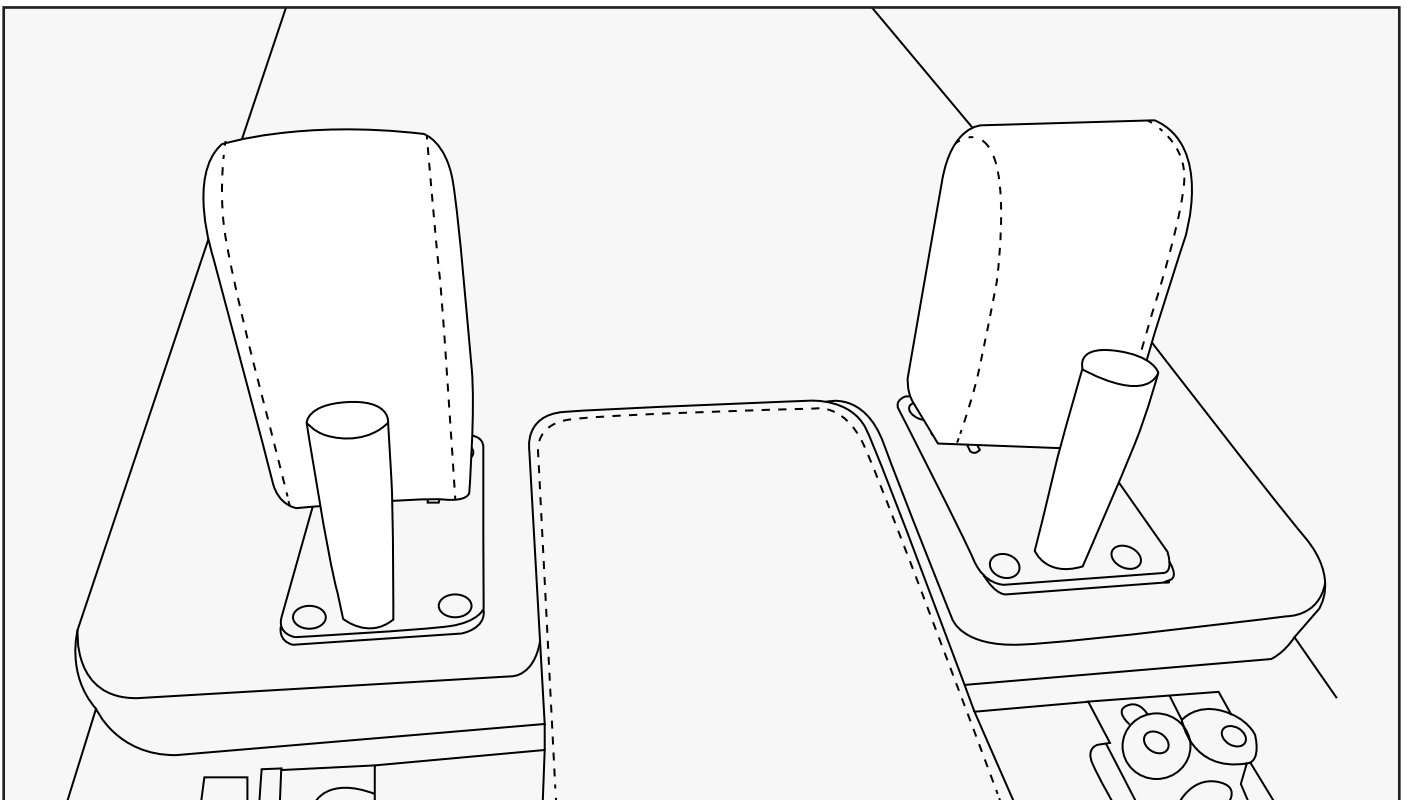

1. Install the shoulder rest blocks as pictured behind the handle using the washer and nut that pre installed on the blocks.
2. Washer goes under the carriage with the bolt.

ASSEMBLE THE ROPES & FEET/HANDLE STRAP

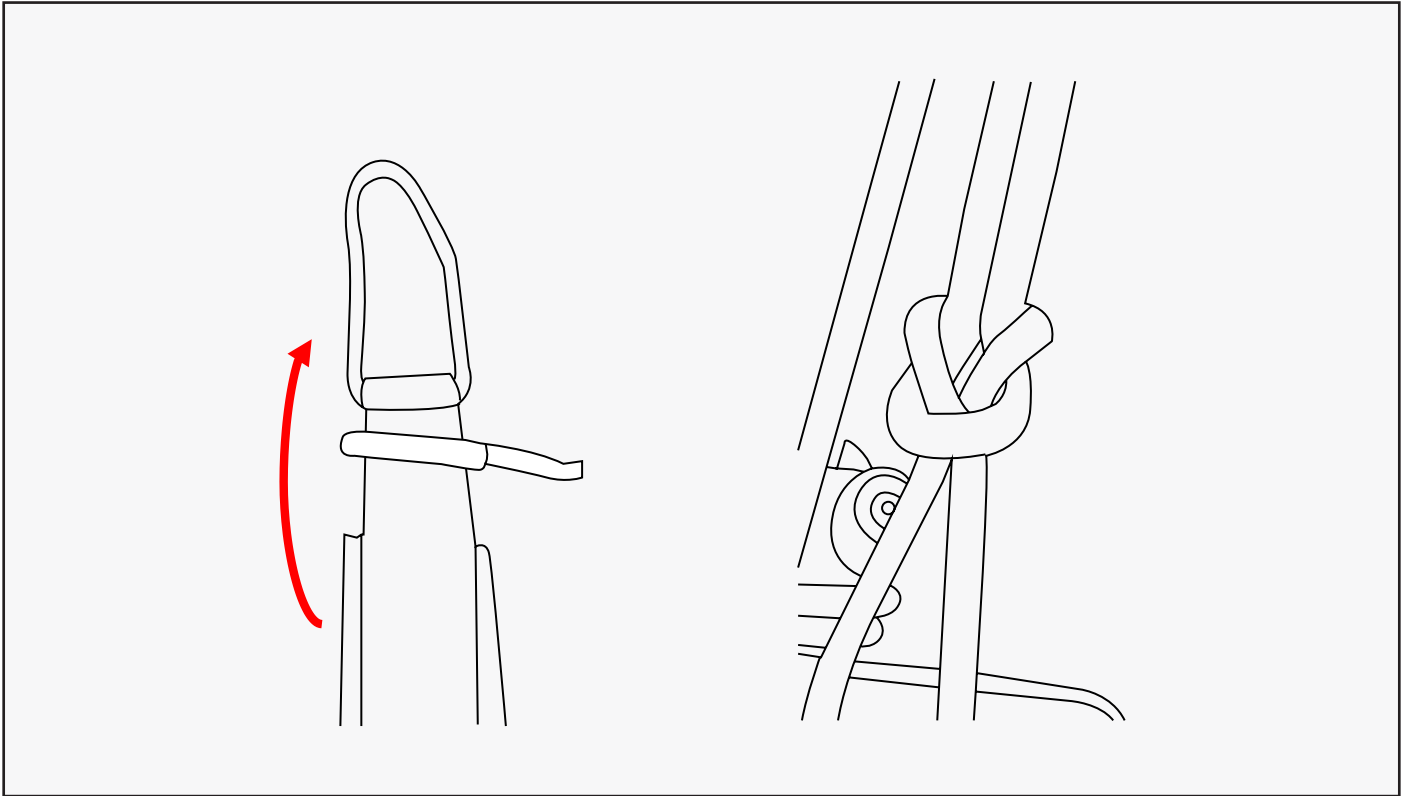

1. Attach the handle strap to the looped end of the rope to form a loop-to-loop knot. Repeat for the other rope then rest your handles on the shoulder blocks.

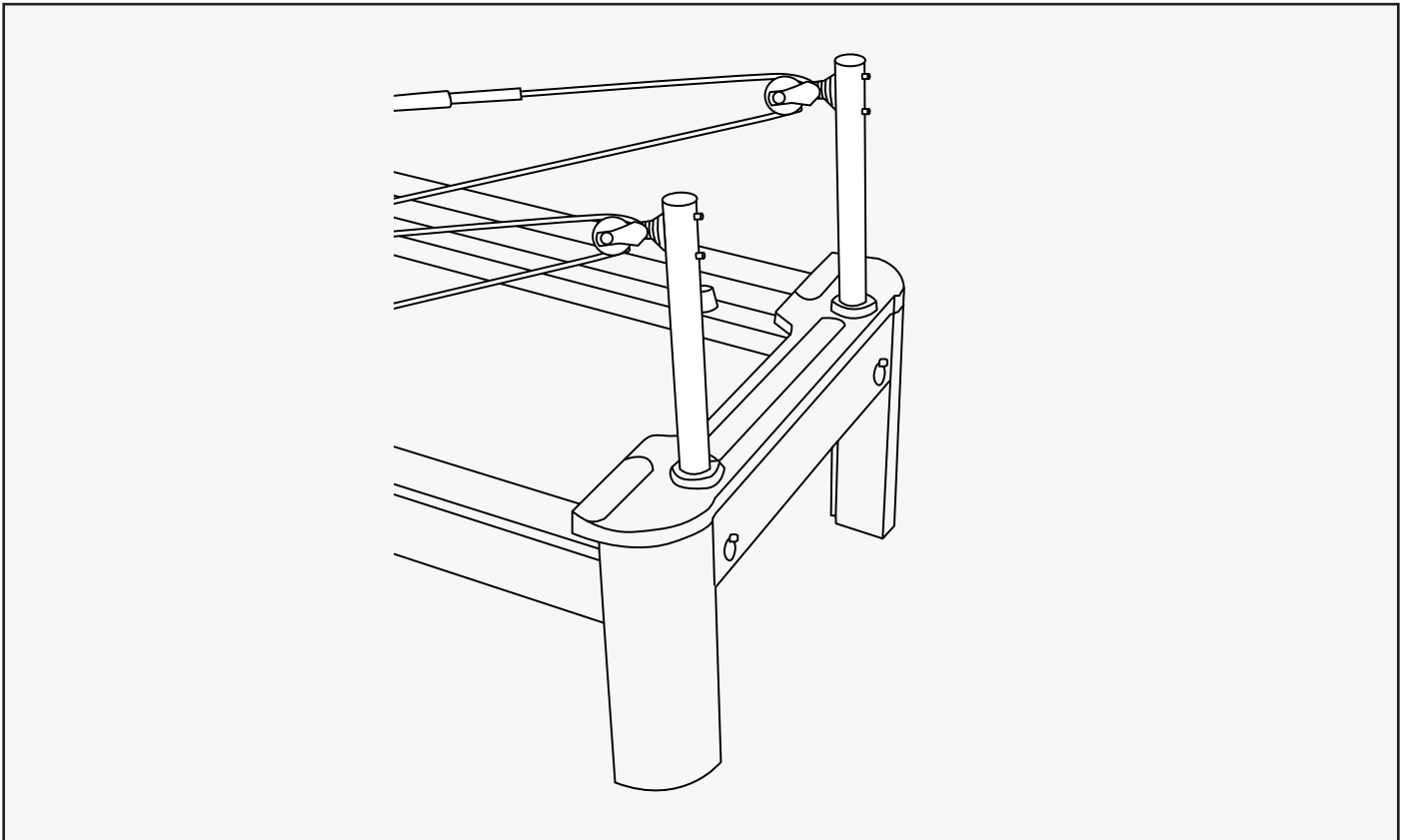

2. Feed the other end of the rope into the pulley on the risers.

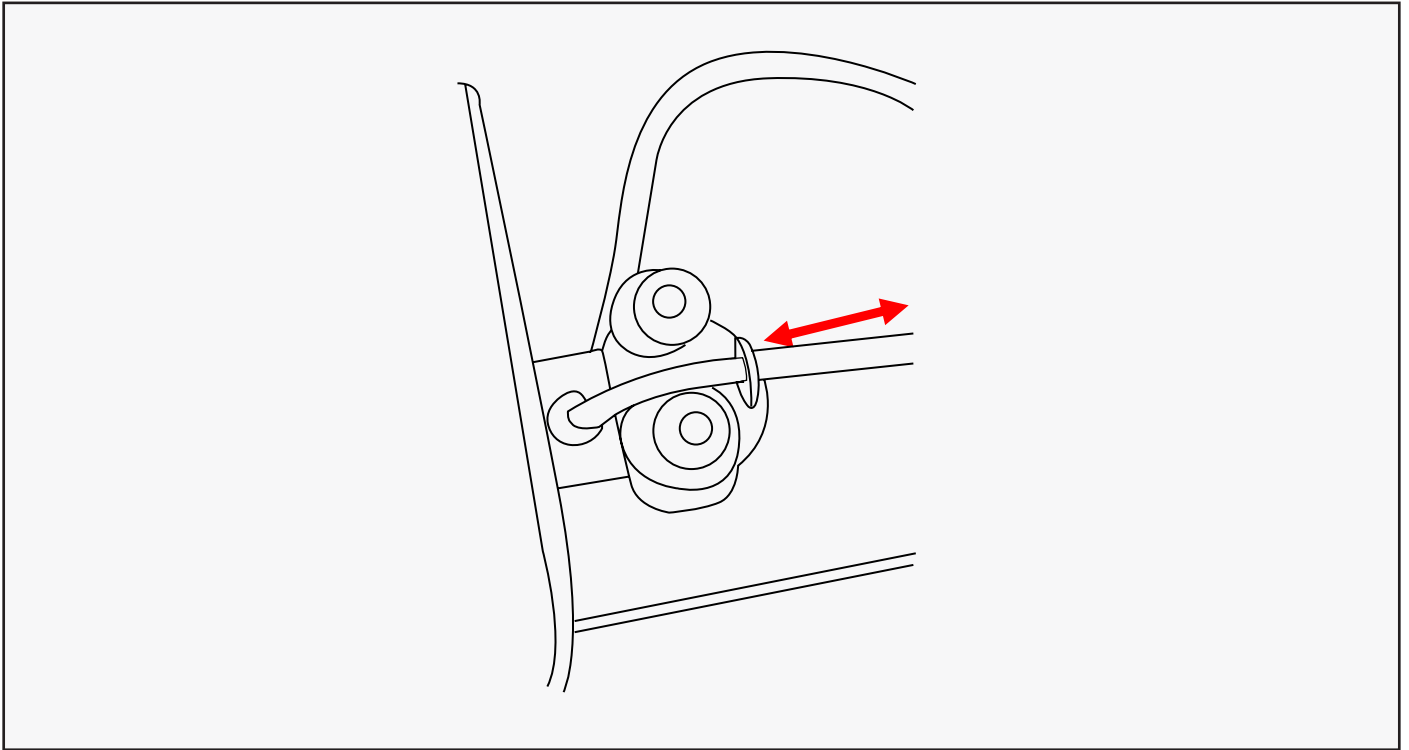

3. Then insert them into the rope clamps on the carriage to your preferred length and according to the exercise you wish to perform.

! **NOTE:** Longer ropes create less tension and shorter ropes create more tension.

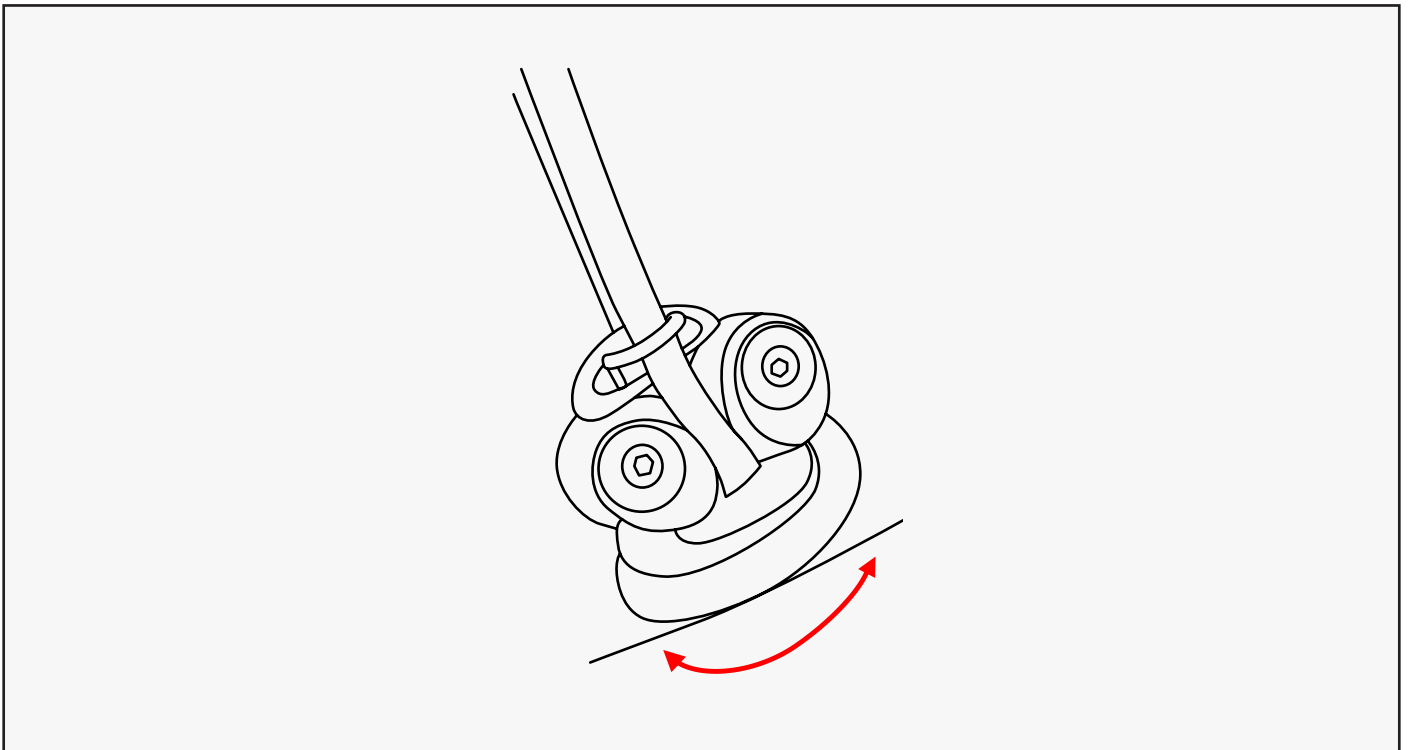

4. For the excess ropes, wrap them around the clamp.

! **NOTE:** Make sure that the ropes are adjusted to equal lengths and the ropes are properly secured. You can ensure they are even by placing them on the shoulder rest blocks and pulling the rope to the preferred length.

INSERT CARRIAGE STOPPER

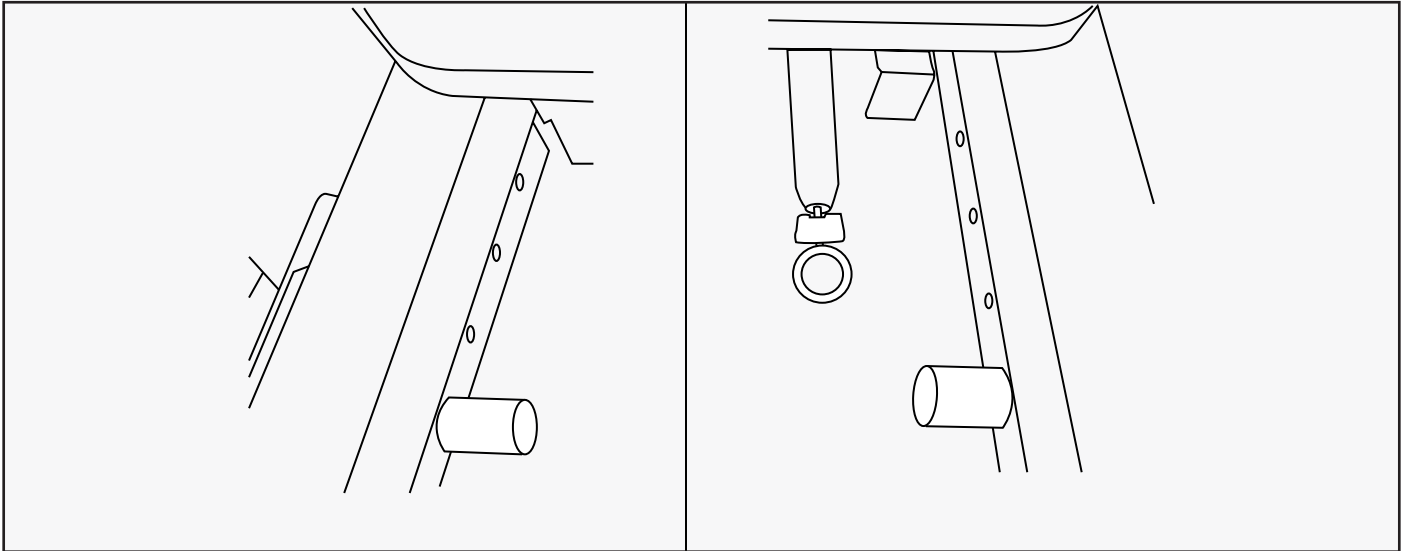

1. Carriage stoppers are pre-installed on the frame but you can move them according to your height.

! **WARNING:** The carriage stopper must be inserted AT ALL TIMES. Using the Reformer without the carriage stopper may cause damage to the gear bar assembly, rollers or spring holder.

HOW TO USE THE FOOT BAR & SPRINGS

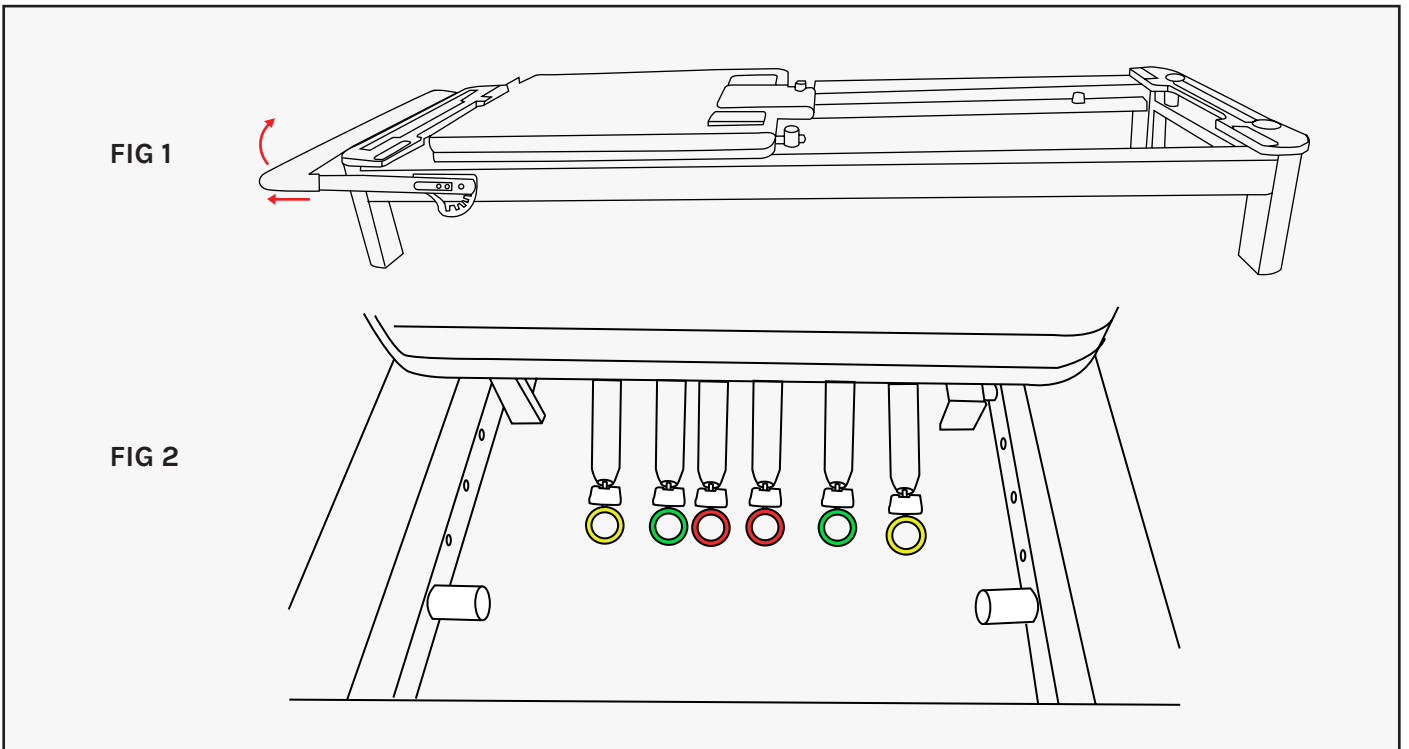

1. Lift up the foot bar to your preferred height (Fig 1).
2. Place the springs onto the gear bar for your preferred resistance level (Fig 2)

Colour	Green	Red	Yellow
Load	Half Load	Heavy Load	Quarter Load

ASSEMBLE FOOT STRAP ATTACHMENT

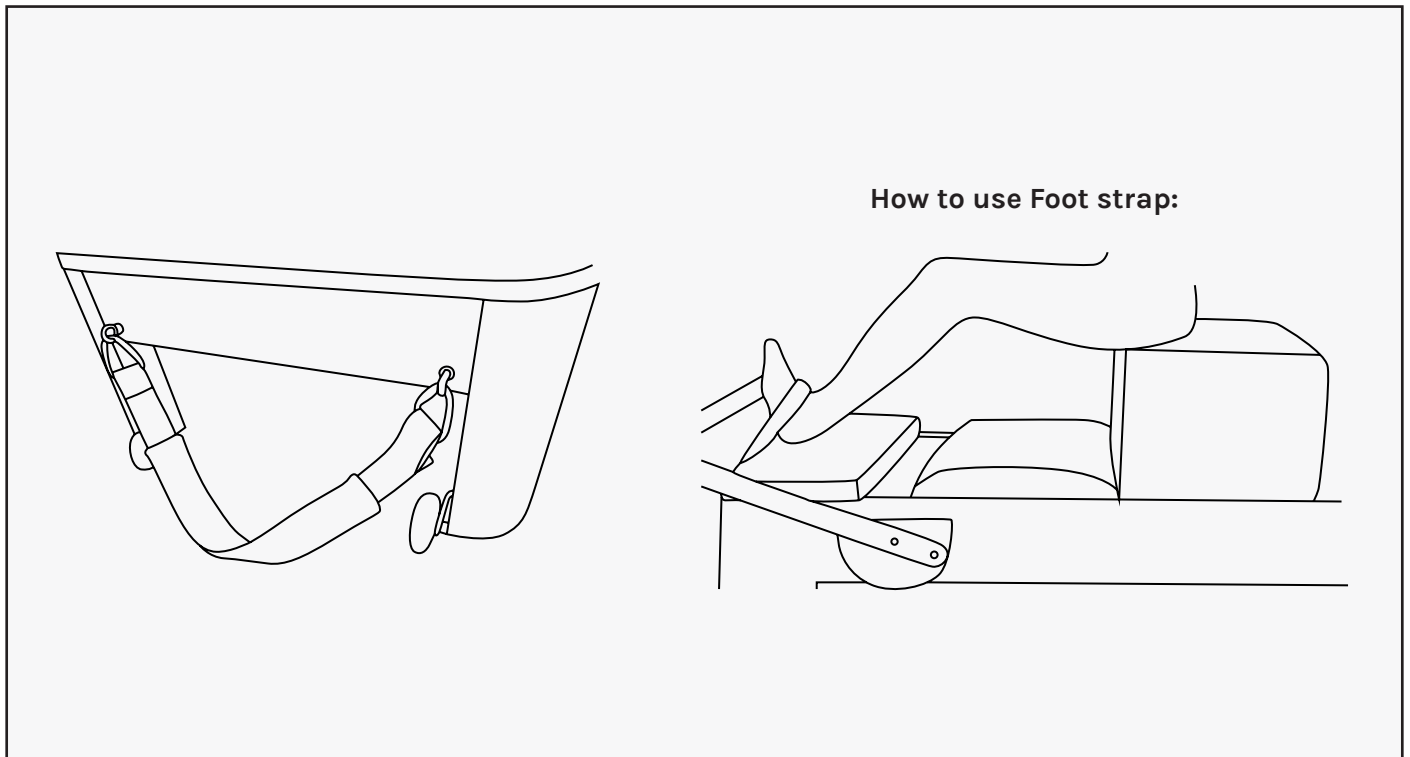

1. Attach the strap attachment as pictured. Ensure to fully tighten the clip.

JUMP BOARD SET UP

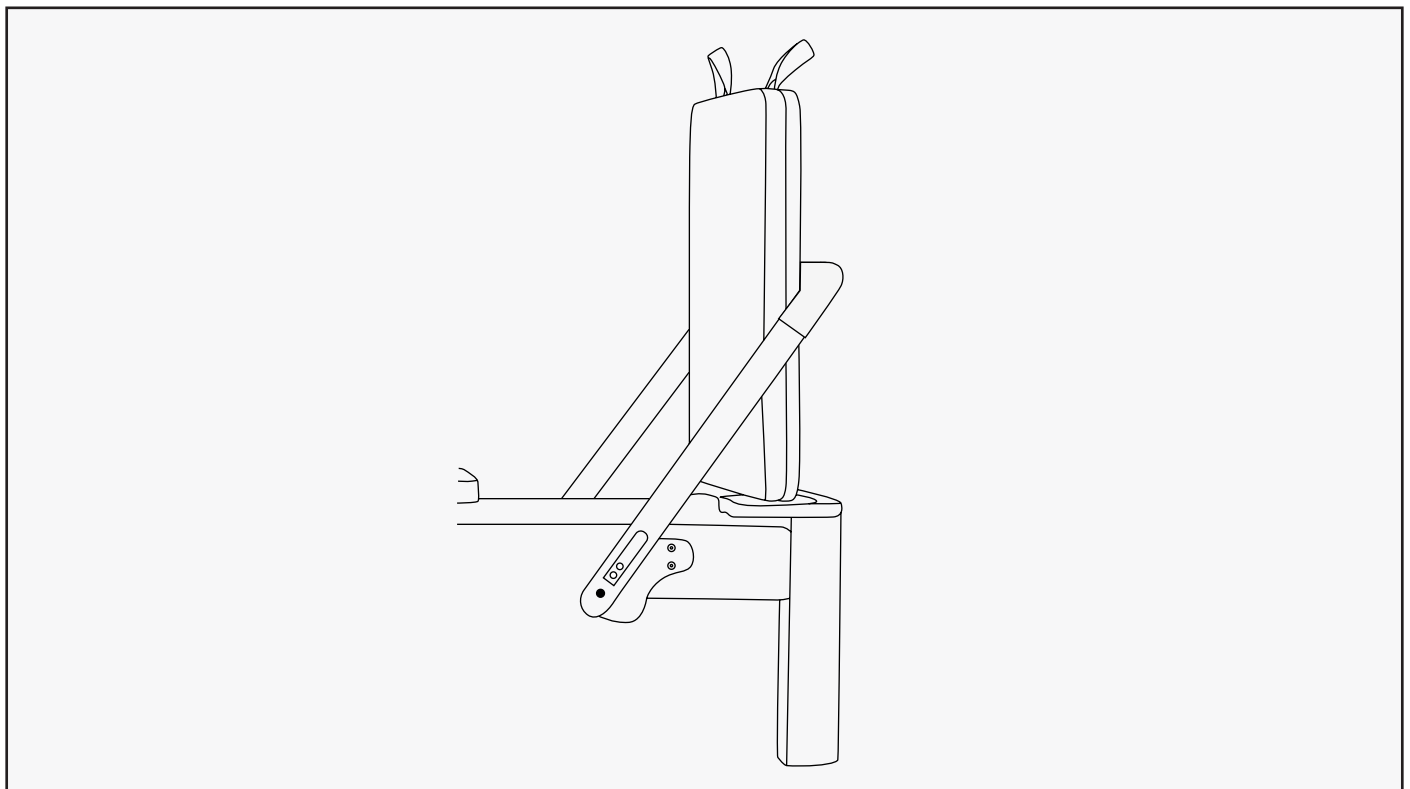

1. Remove the foot platform by lifting it up and out. Then slot in the jump board.

BOX SET UP

1. Place the box on the carriage vertically or horizontally under the shoulder pads for your preferred exercise.

STORING THE REFORMER UPRIGHT

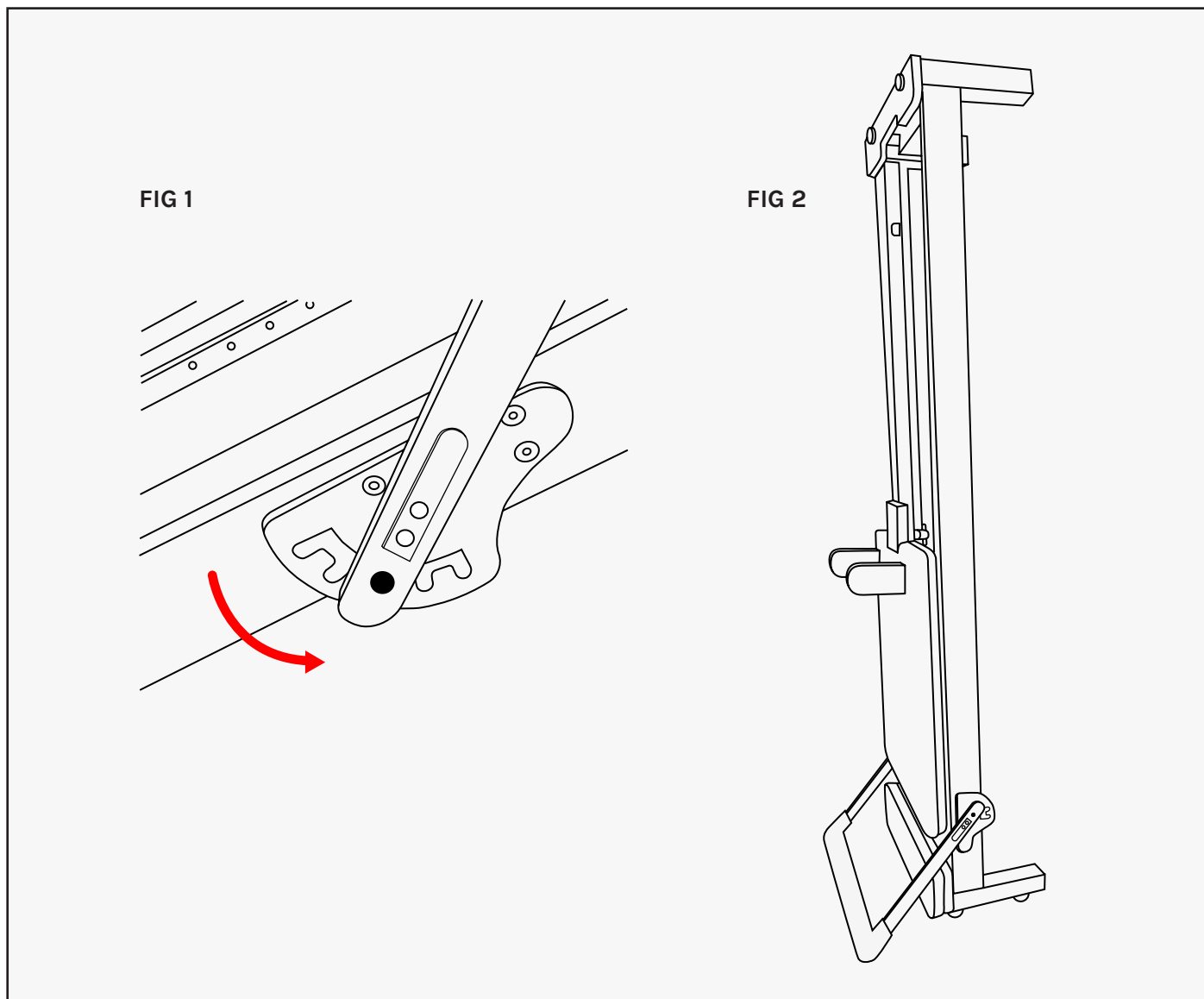

! **WARNING:** You need a height of 2.5m for your ceiling

1. Remove the Risers and Rope from the Reformer.
2. Move the foot bar to the angle as shown in Fig 1.
3. Lifting from the Riser end of the Reformer tilt it until it is on the vertical position and resting on the wheels and foot bar (Fig 2).

MOVING THE REFORMER

1. Ensure to remove the Foot strap from the frame so it is not in the way of the wheels.
2. Hold the Reformer frame from the Riser side and tilt it onto the wheels of the other end. You can now move to your desired location.

REPLACING SPRINGS

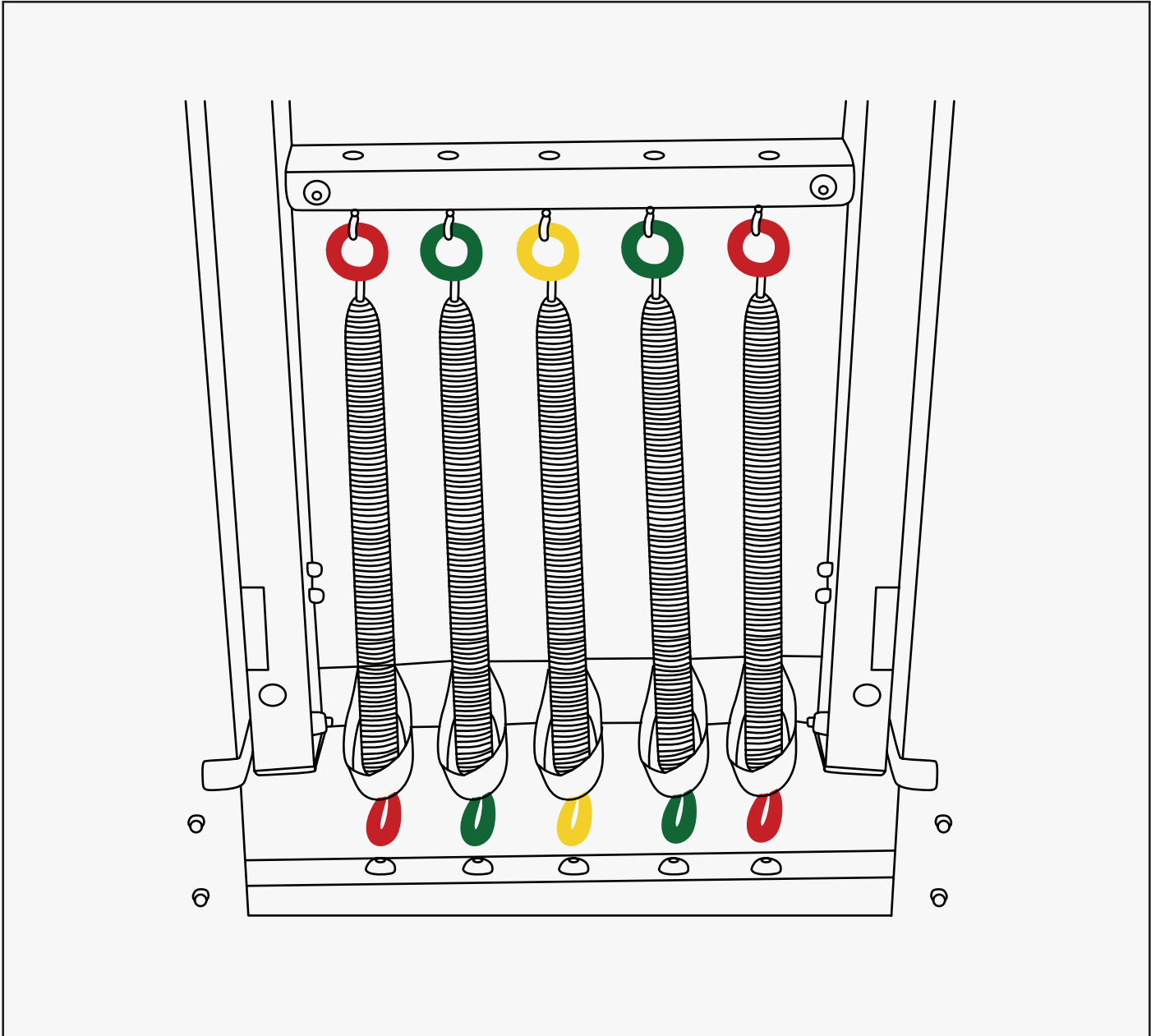

To replace worn springs simply unhook the springs from both ends. Ensure to place the coloured springs in the same spot.

INSTALL THE FOOT BAR TO FOOT BAR BRACKET

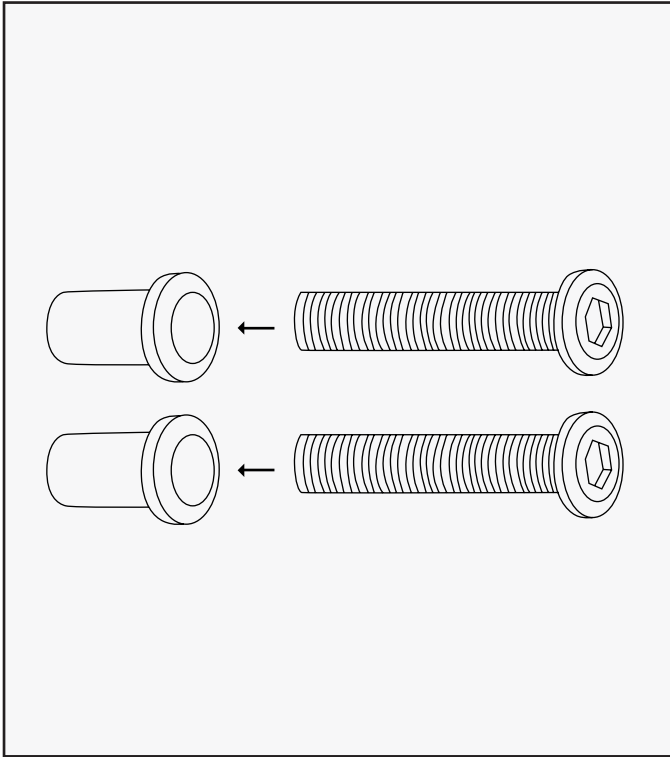

1. Place the Bolt into the bolt holder sleeve.

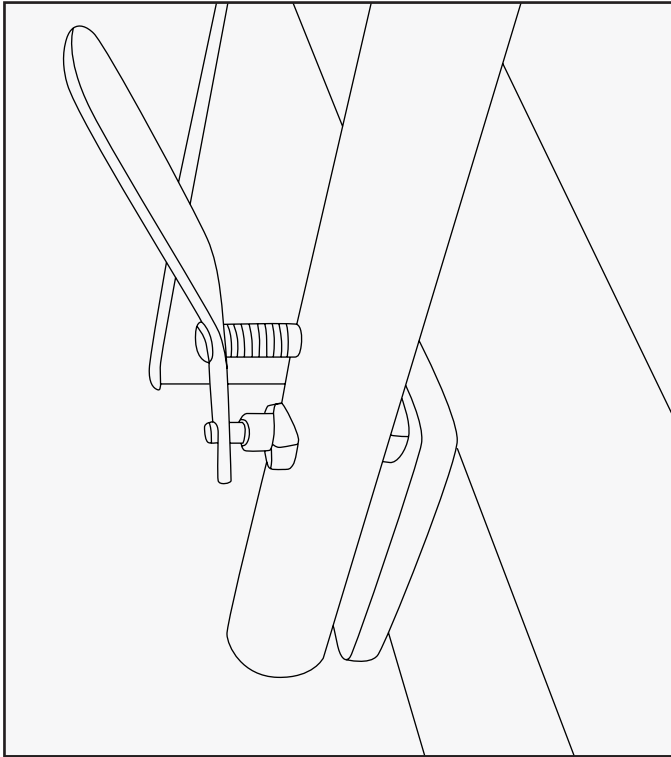

2. Line up the hole of the foot bar to the foot bar bracket on the frame.

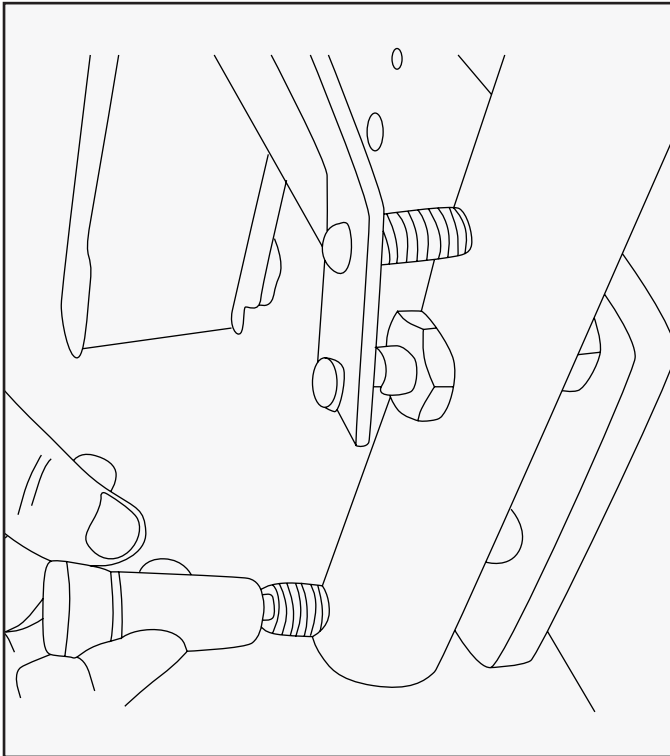

3. Insert the screw to the foot bar post but not into the bracket yet.

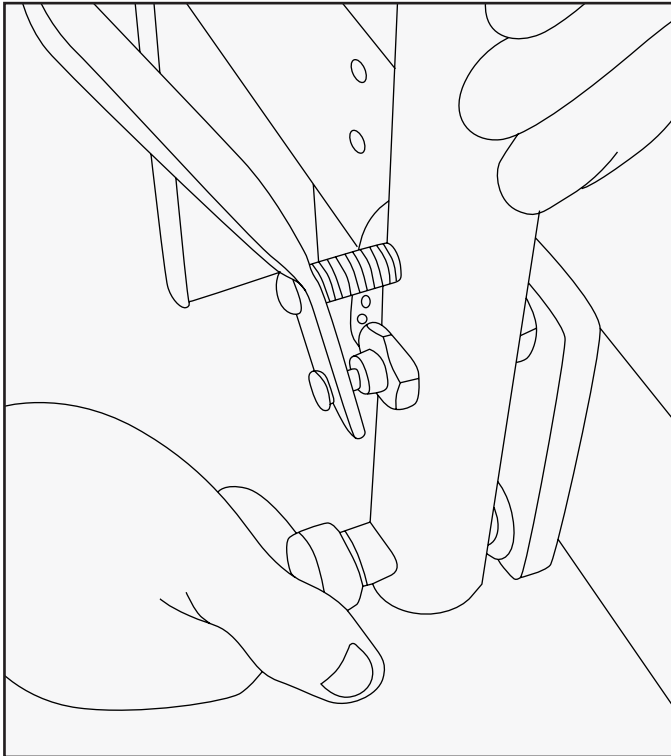

4. Add the plastic washer to the bolt, in between the foot bar and the foot bar bracket and hand tighten. Repeat for the other side.

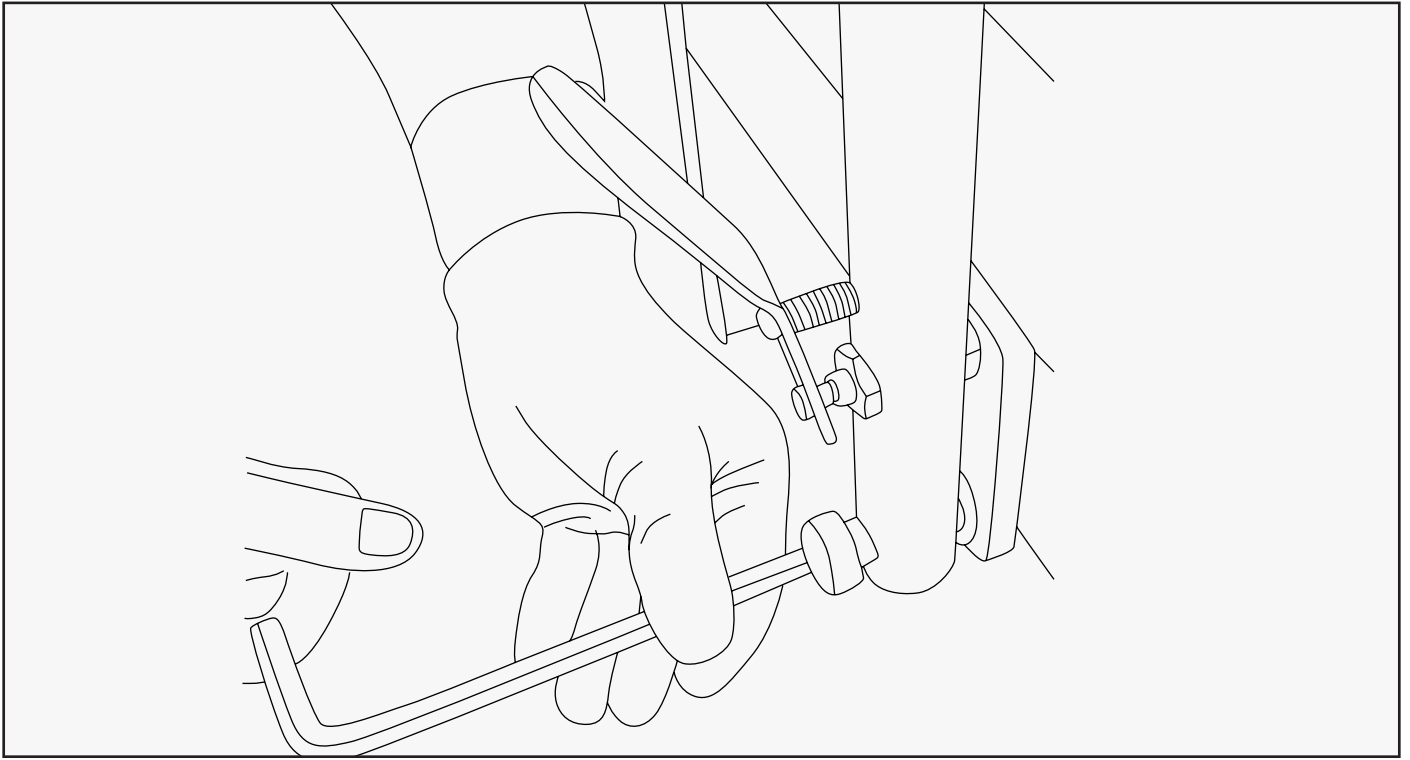

5. Use the Allen key to fully tighten the bolt. Repeat for the other side.

IV. EXERCISE GUIDE

! PLEASE NOTE:

Before beginning any exercise program, consult your physician. This is important especially if you are over the age of 45 or individuals with pre-existing health problems.

The pulse sensors are not medical devices. Various factors, including the user's movement, may affect the accuracy of heart rate readings. The pulse sensors are intended only as an exercise aid in determining heart rate trends in general.

Exercising is a great way to control your weight, improve your fitness and reduce the effect of aging and stress. The key to success is to make exercise a regular and enjoyable part of your everyday life.

The condition of your heart and lungs and how efficient they are in delivering oxygen via your blood to your muscles is an important factor to your fitness. Your muscles use this oxygen to provide enough energy for daily activity. This is called aerobic activity. When you are fit, your heart will not have to work so hard. It will pump a lot fewer times per minute, reducing the wear and tear of your heart.

So as you can see, the fitter you are, the healthier and greater you will feel.

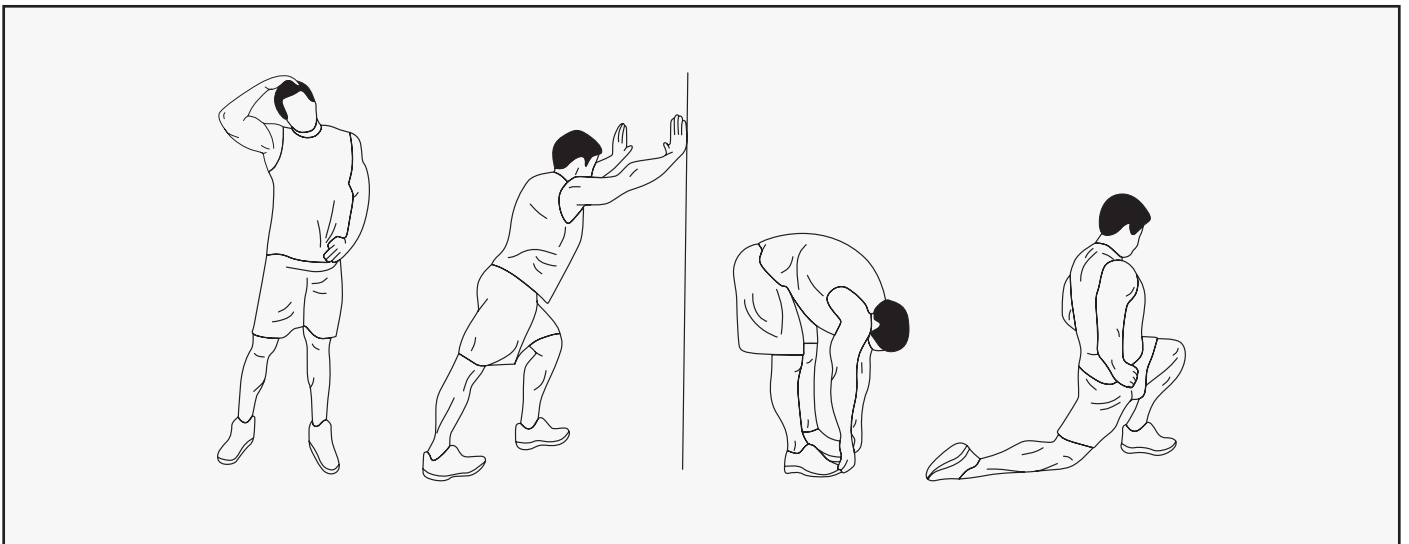

WARM UP

Start each workout with 5 to 10 minutes of stretching and some light exercises. A proper warm-up increases your body temperature, heart rate and circulation in preparation for exercise. Ease into your exercise.

After warming up, increase the intensity to your desired exercise program. Be sure to maintain your intensity for maximum performance. Breathe regularly and deeply as you exercise.

COOL DOWN

Finish each workout with a light jog or walk for at least 1 minute. Then complete 5 to 10 minutes of stretching to cool down. This will increase the flexibility of your muscles and will help prevent post-exercise problems.

WORKOUT GUIDELINES

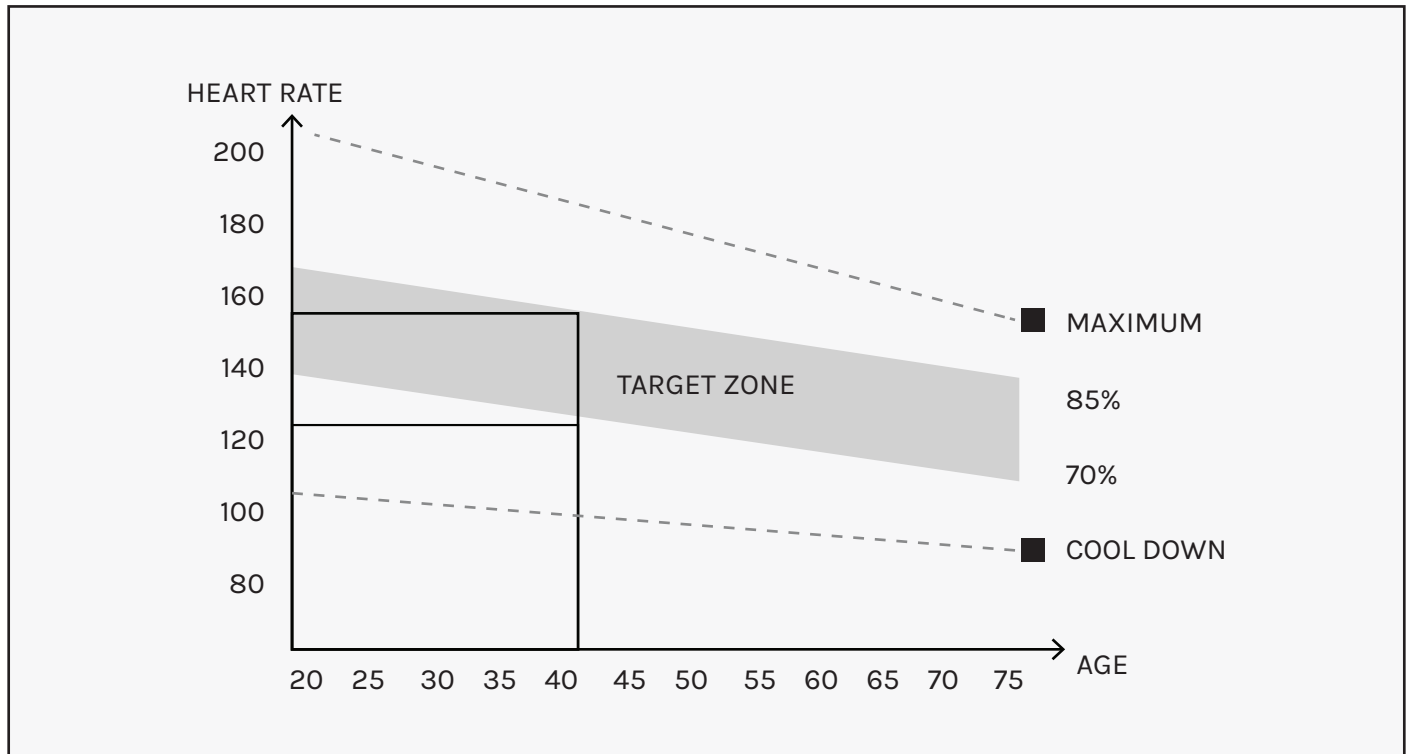

! This is how your pulse should behave during general fitness exercise. Remember to warm up and cool down for a few minutes.

V. WARRANTY

AUSTRALIAN CONSUMER LAW

Many of our products come with a guarantee or warranty from the manufacturer. In addition, they come with guarantees that cannot be excluded under the Australian Consumer Law. You are entitled to a replacement or refund for a major failure and compensation for any other reasonably foreseeable loss or damage.

You are entitled to have the goods repaired or replaced if the goods fail to be of acceptable quality and the failure does not amount to a major failure. Full details of your consumer rights may be found at www.consumerlaw.gov.au.

Please visit our website to view our full warranty terms and conditions:
<http://www.lifespanfitness.com.au/warranty-repairs>

WARRANTY AND SUPPORT

Any claim against this warranty must be made through your original place of purchase. Proof of purchase is required before a warranty claim may be processed.

If you have purchased this product from the Official Lifespan Fitness website, please visit <https://lifespanfitness.com.au/warranty-form>

For support outside of warranty, if you wish to purchase replacement parts or request a repair or service, please visit <https://lifespanfitness.com.au/warranty-form> and fill in our Repair/Service Request Form or Parts Purchase Form.

Scan this QR code with your device to go to lifespanfitness.com.au/warranty-form





WWW.LIFESPANFITNESS.COM.AU