



# LUXCLOUD AIR - ZERO GRAVITY HEATED MASSAGE CHAIR

## USER MANUAL



Find the  
Digital Manual  
Online



Product may vary slightly from the item pictured due to model upgrades.



**Read all instructions carefully before using this product.  
Retain this owner's manual for future reference.**

**NOTE:**

This manual should not be used to guide your purchasing decision. Your product, and the contents inside its carton, may vary from what is listed in this manual. This manual may also be subject to updates or changes. Updated manuals are available through our website at [www.lifespanfitness.com.au](http://www.lifespanfitness.com.au)



# TABLE OF CONTENTS

I. Important Safety Instructions .....	03
II. Name & Function of Each Component .....	06
III. Preparation Before Use .....	07
IV. Grounding Instructions .....	08
V. Installation .....	10
VI. Operation .....	14
VII. Storage .....	17
VIII. Maintenance .....	17
IX. Troubleshooting .....	18
X. Warranty .....	19

# I. IMPORTANT SAFETY INSTRUCTIONS

Please read these "SAFETY PRECAUTIONS" carefully before use to ensure proper operation.

These "SAFETY PRECAUTIONS" will greatly assist you in the correct use of this massage chair.

To clearly indicate the levels of danger and potential damage, accidents caused by incorrect use are classified into "WARNING" and "Prohibited". Follow these instructions strictly.

## **WARNING**

---

- Use this appliance only for its intended purpose as described in this manual. Do not use attachments not recommended by the manufacturer.
- This product is intended for domestic use only.
- Never operate this appliance if it has a damaged cord or plug.
- Keep the cord away from heated surfaces.
- Please empty your pockets and remove all arm jewelry and watches before using this chair.
- Do not operate where aerosol (spray) products are being used.
- To disconnect, turn all controls to the off position, then remove the plug from the outlet.
- Connect this appliance only to a properly grounded outlet. See Grounding Instructions.
- Do not remove the back cushion or play with the roller mechanism.
- Do not remove the bottom seat or play with the actuators.
- Keep the cord out of heavy traffic areas.
- Always unplug the power cord from the electrical outlet immediately after use.
- Do not operate any equipment with damaged parts.
- Any use not recommended by the manufacturer may cause electrical shock or injury.
- Do not touch or re-wire the wires connected to the master box.
- Do not attempt to repair or adjust any electrical or mechanical functions on this unit. Doing so will void the warranty.
- Do not put your hands or head under the chair.
- When using the massage chair, ensure that the footrest is in the lowest position.
- When getting off the chair ensure the foot rest is on the ground. Do not get out of the chair while it is on recline position.

## PROHIBITED

---

- Do not allow children to play near the chair, especially during operation.
- Do not leave mobility-impaired or speech-impaired individuals alone in the chair.
- Do not place or store this machine near damp areas such as swimming pools or bathrooms.
- Do not apply force to the massage rollers.
- Do not stand on the chair or place heavy items on it.
- Do not use the chair in environments that are dusty, greasy, or lacking oxygen.
- Do not place near a steam oven, open fire, or heat source.
- Wear suitable clothing; do not use the massage chair with bare skin.
- Do not place the chair directly in the sun.
- Do not use an electric blanket while using the massage chair.
- Do not use outdoors.
- Do not use while smoking.
- Do not use immediately after meals.
- Do not sit on the back cushions, armrests, or legs.
- Do not use the massage chair when your body is wet or moist, as it can result in electrical shock.
- Do not operate with more than one person.
- Do not use while wearing head ornaments, as this can result in injury.
- Do not stumble over electrical wires or connections.

## POWER OFF

---

- Before performing maintenance, please unplug the power plug. Additionally, do not insert or unplug the power plug with damp hands to avoid electric shock.
- When the massage chair is not in use, switch off the power and remove the plug from the socket. If the power goes off, immediately cut off the power supply and unplug the power plug from the socket.



### CAUTION

- Please avoid using the massager after drinking or if you are not feeling well.
- Do not massage the head, elbow joints, knees, chest, or abdomen directly on the massage ball.
- Do not damage the power cord or operate the massager with a damaged power cord. This may result in electric shock or mechanical failure. Please contact the service center for a detailed inspection.

## **MEDICAL WARNINGS**

---

All users should consult a physician and exercise caution when operating this system. This product must be grounded to reduce the risk of electric shock. Improper grounding can result in a risk of electric shock. Check with a qualified electrician if you are unsure about the grounding of the product.

### **NOT RECOMMENDED FOR THE FOLLOWING PEOPLE:**

---

1. Patients with serious hyperostosis
2. Patients with thrombosis or swollen lumps
3. Patients with serious heart conditions
4. Pregnant women
5. People who consume large amounts of alcohol
6. People with diabetes
7. People suffering from high fever
8. Patients with malignant tumors or malignant abscesses
9. People with distorted joints
10. People with serious skin conditions
11. People with spinal injuries
12. Minors under 16 years or people unable to control their behavior (e.g., mental patients, people with paralysis)

## II. NAME & FUNCTION OF EACH COMPONENT

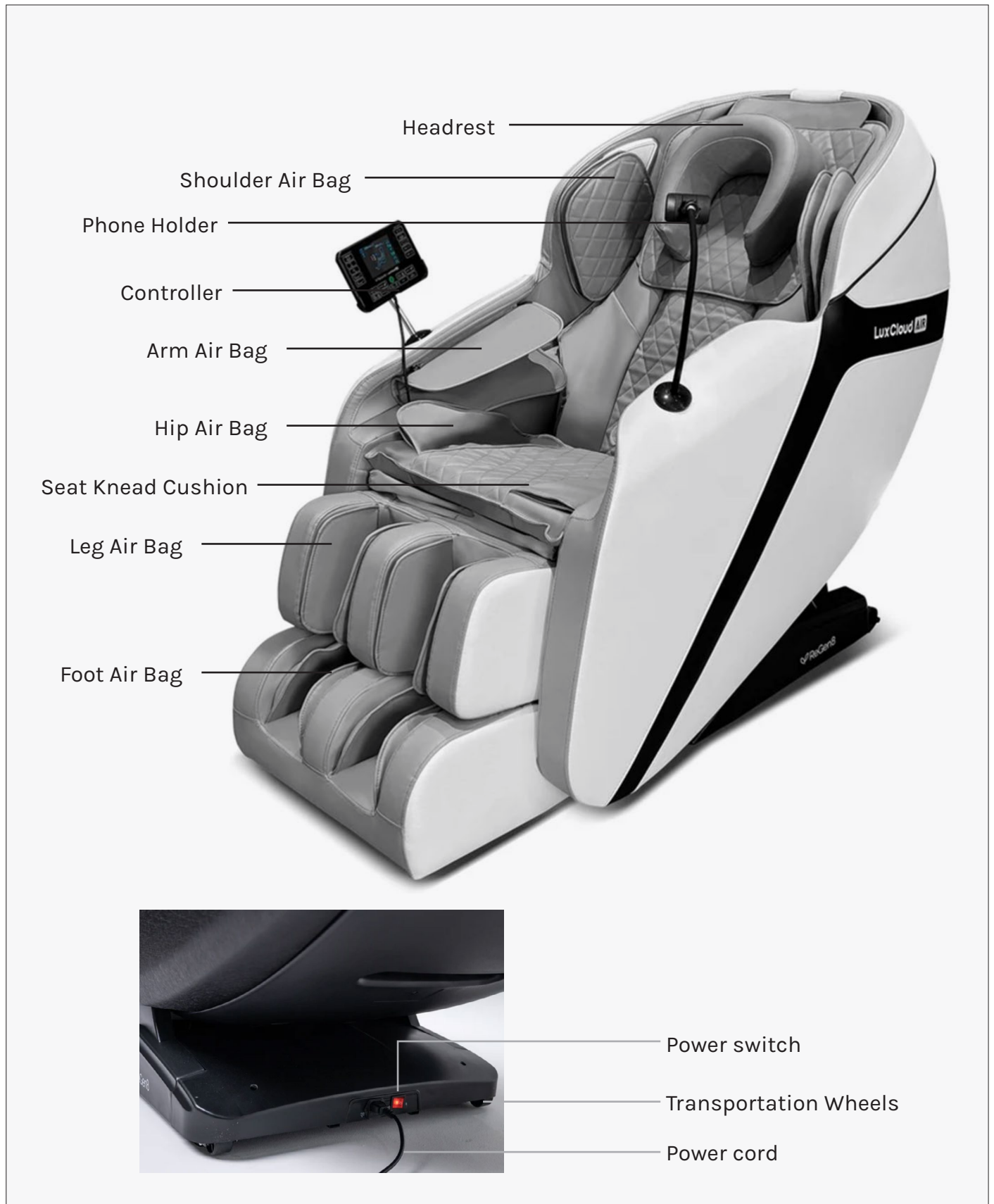



Head & Neck Knead Cushion

Speakers

Backrest Knead Cushion

Thigh Air Bags

Leg Knead

Foot Knead

# III. PREPARATION BEFORE USE

## BEFORE USING THE MASSAGE CHAIR:

---

- Please tidy up the cables to avoid tangling or damage.
- When the chair moves forward or backward to its original position, ensure there are no children, pets, or objects in the way to prevent accidents.
- Place a carpet or other pad under the massage chair to avoid any potential damage or marks on the floor.

## AFTER USING THE MASSAGE CHAIR:

---

Turn off the chair and unplug it from the power supply socket when not in use to prevent children from accidentally starting the chair.

- Turn off the chair and unplug the power cable from the power supply socket after use. Disconnect the controller and store it carefully.

## DAILY CHECK

---

During daily use, please check for the following issues:

- Scorched smell
- Power intermittently turning on and off when touching the wire
- Hot power supply cord
- Other abnormal phenomena



### CAUTION

If any of the above problems occur, please turn off the power supply and contact the distributor or manufacturer for assistance.



# IV. GROUNDING INSTRUCTIONS

This product must be grounded. Grounding provides the least resistance for electrical current and will reduce the risk of electric shock. The plug must be plugged into an appropriate outlet that is professionally installed and grounded in accordance with all local codes and ordinances. Ensure that the product is connected to an outlet which contains the same configuration as the plug. Do not use an adaptor for this product.

This product is for use on a nominal circuit and has a grounding plug that looks like the plug illustrated in sketch A. Make sure that the product is connected to an outlet having the same configuration as the plug. No adapter should be used with this product.

**Danger:** Improper connection of the equipment-grounding conductor can result in risk of electric shock. Check with a certified electrician if you are in doubt as to whether the product is properly grounded. Do not modify the plug provided with the product. If it will not fit the outlet, have a proper outlet installed by an electrician.

## WARNING

- NEVER use a ground fault circuit interrupt (GFCI) wall outlet with this treadmill. Route the power cord away from any moving part of the treadmill including the elevation mechanism and transport wheels.
- NEVER operate the Chair using a generator or UPS power supply.
- NEVER remove any casing without first disconnecting AC power.
- NEVER expose the Chair to rain or moisture. This Chair is not designed for use outdoors, near pools or in any other high humidity environment.

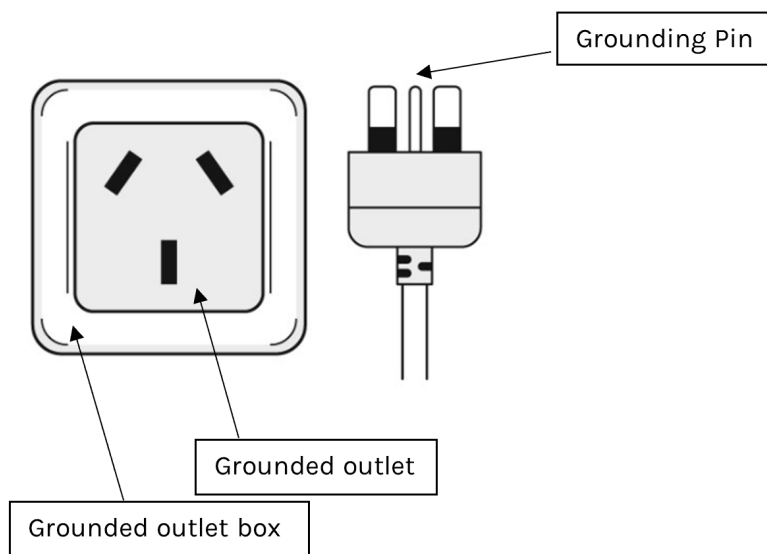

# V. INSTALLATION

## Accessories from the Box

### Seat Cushion Connection:

Lift up the seat cushion and check the cable line and air cushion ports are properly connected.

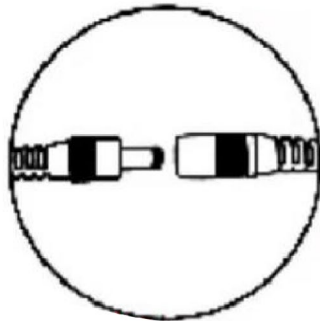
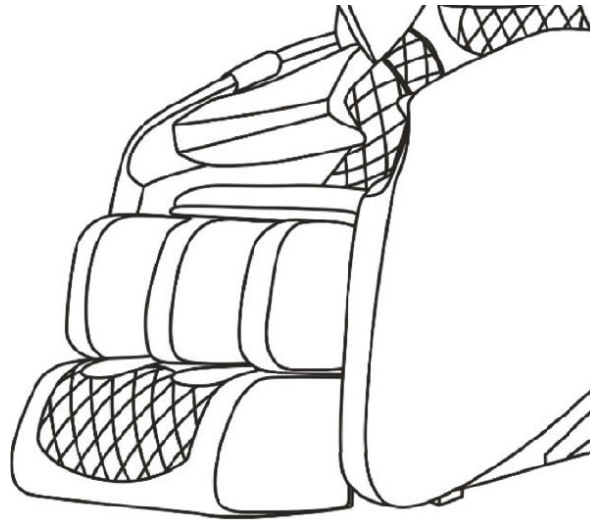

Connect the cable line if not connected.

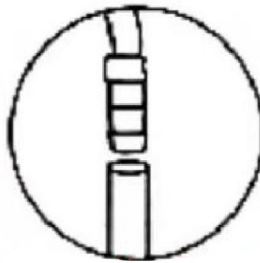

Connect the air cushion port if not connected.

### Air Tube Connection for Head and Back Rest:

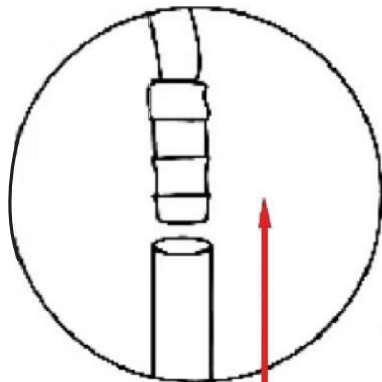

Lift up the headrest cushion to check the air tube is properly connected and connect if necessary.

## LEG CUSHION SET UP

1. Remove the Leg cushion from the Chair seat.
2. Turn the chair until the feet side are to the ground.

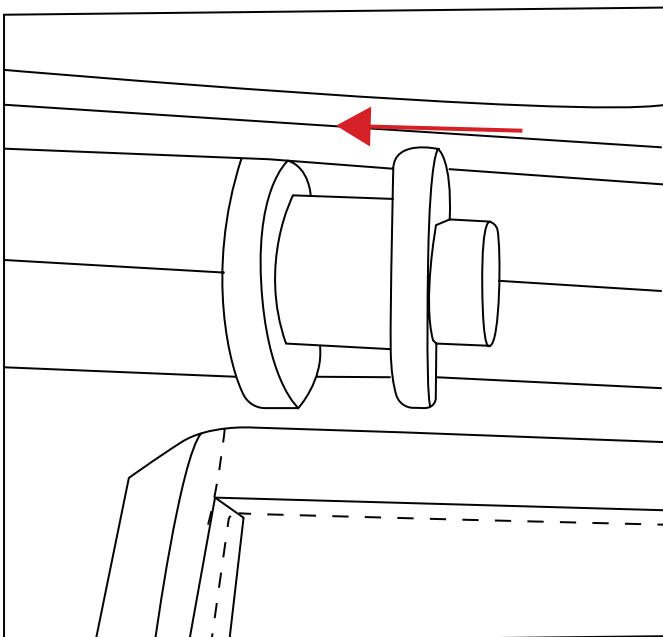
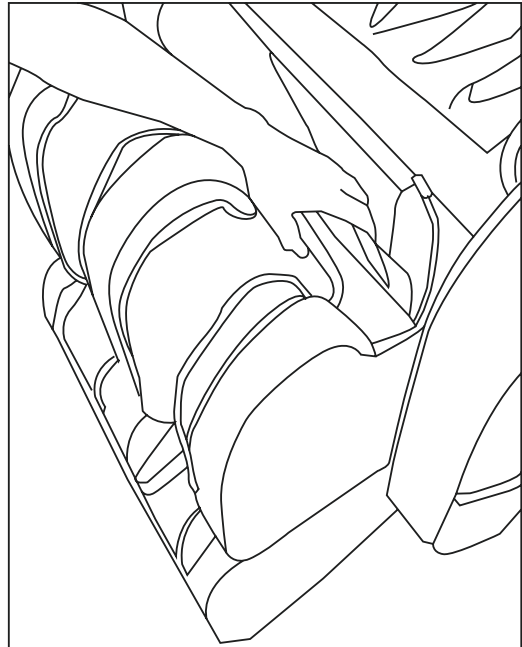

3. Insert the leg cushion onto the metal tube at the left corner edge of the seat.

4. Repeat the same on the right side while also inserting a pin in the middle.

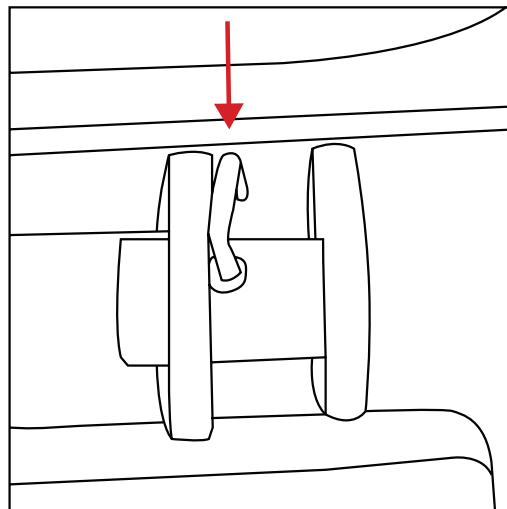
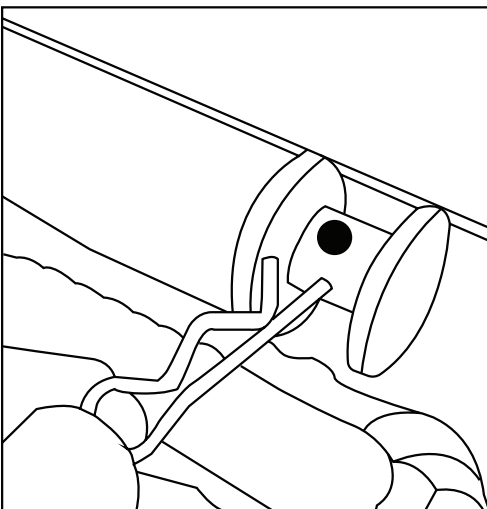

## IMPORTANT

---

1. Allow enough space when setting up.
2. Lift out of box and place the massage chair in a location with enough space for the back of the chair to recline and the stand to rise.
3. Ensure there is at least 50 cm of space behind the massage chair and at least 50 cm in front of it. To prevent it from knocking into the walls or objects when it reclines.
4. Do not place the power cord in the electric control box at the rear of the chair.
5. Ensure the cord is not caught under the massage chair.

## SURROUNDING ENVIRONMENT

---

- Keep the massage chair away from damp places (e.g., bathroom) to avoid electric leakage.
- Place the chair on a flat, non-slippery surface.
- Keep the massage chair away from high-temperature sources (e.g., stove, in direct sunlight) to avoid fire or damage to the leather material.

## INSTALLATION FOR THE REMOTE CONTROL AND PHONE HOLDER

---

1. On both sides of the arm rest there is a hole to attach the holders. Insert the remote control holder and the phone holder onto the hole, lining up with the thread. You can place them on either sides.
2. Turn the screw rod clockwise until fully tightened.
3. Place the remote control on the bracket.

## TURN ON POWER SUPPLY

---

1. Attach the Power Cord to the socket at the back of the chair and plug into the main power point.

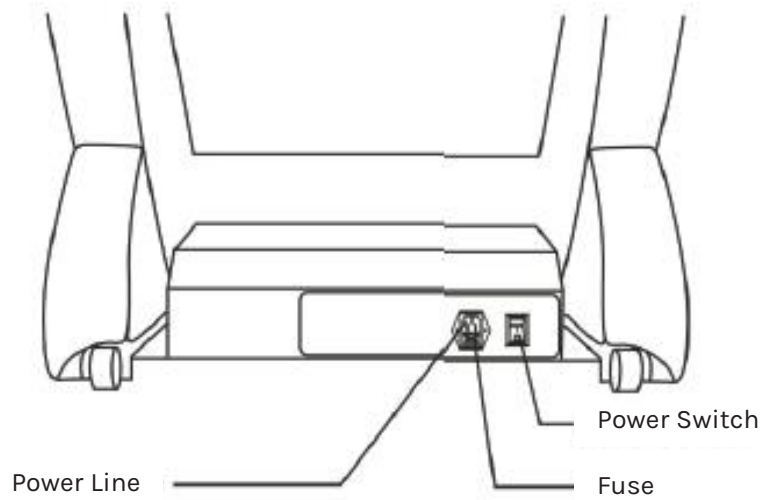

### CAUTION

- Before switching on the chair, please ensure there is no damage to the power cord or other exposed wires.
- Make sure the power switch is off before connecting the chair to electricity.

## MOVING THE CHAIR

---

- First switch off and unplug the chair.
- There are moving rollers at the bottom of the chair.
- Raise the back to about a 45-degree angle, until the wheels touch the ground.
- Carefully move the chair to the designated location and gently lower back down. You can have someone assist you from the front to help lift, move, and lower the chair.

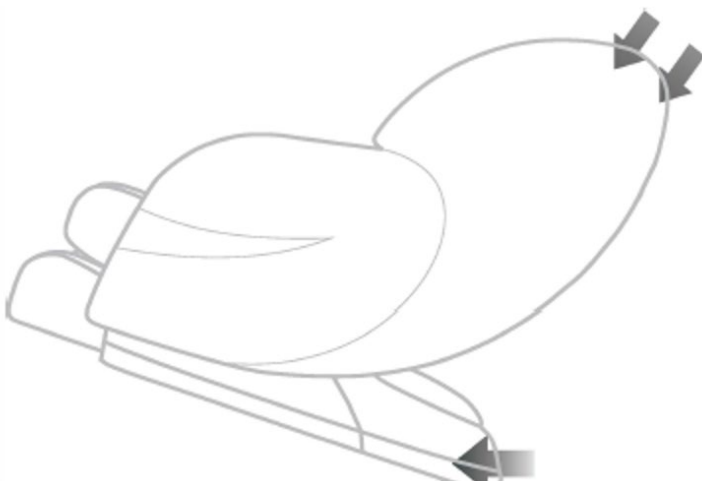

### CAUTION

- Do not move the chair when there is someone in it.
- Ensure to clear the space for the new area.
- Seek assistance if it is too heavy for one person to move.

# VI. OPERATION

## Bluetooth Connection

1. Turn on Bluetooth on your device and search for the equipment Bluetooth code 888.
2. After connecting to Bluetooth, you can now play the music from your device.



### IMPORTANT

You must manually turn off or on the Heat and Knead functions. In Auto Program the functions will be turned on and off when the program finishes.

## Remote Control

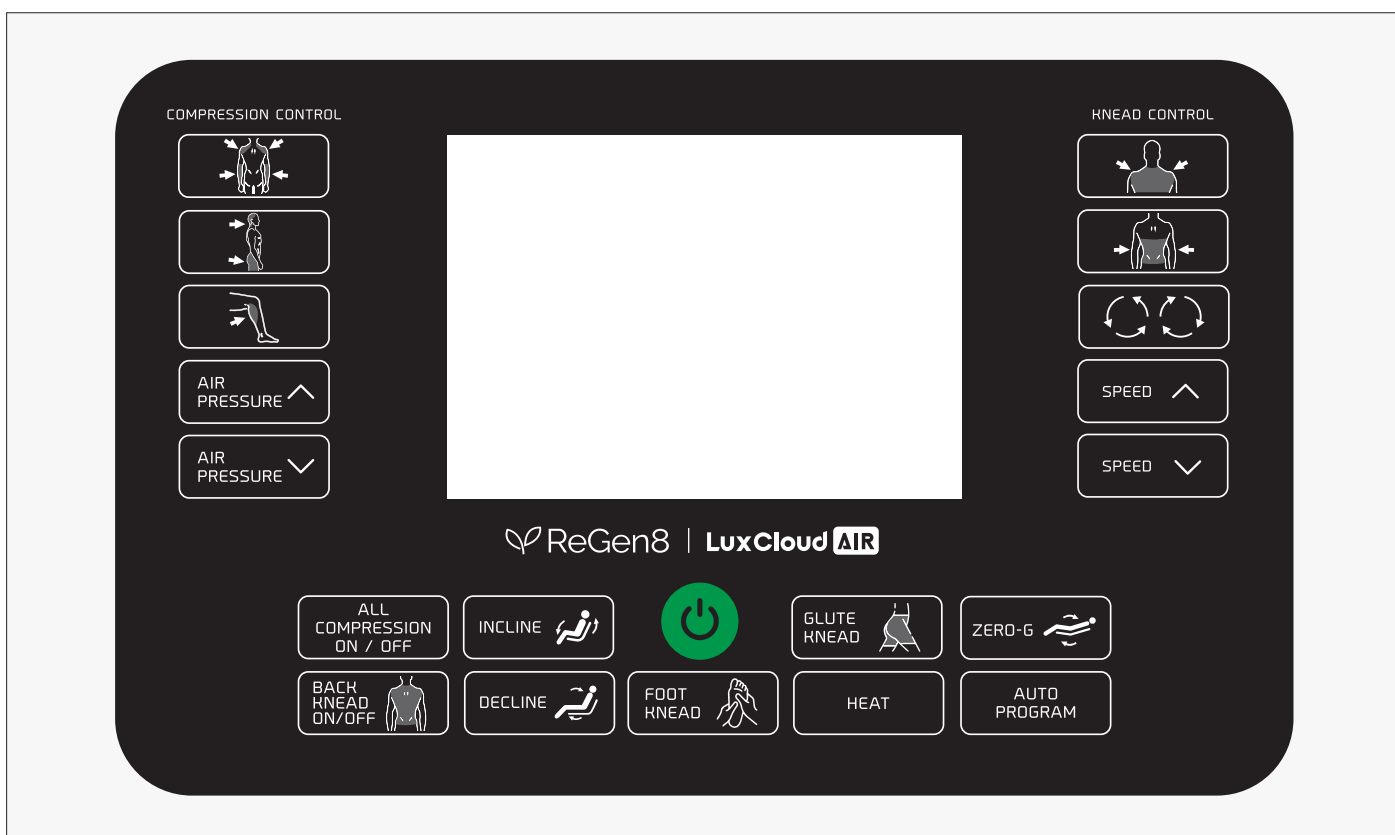

- |    |   |
|----|---|
| 1. | Compression Control - Arms & Shoulder, Upper & Lower back, Legs |
| 2. | Air Pressure Up/Down  |
| 3. | Knead Control - Upper and Lower back                            |
| 4. | Rotation Icon   |
| 5. | Speed Up/Down   |
| 6. | Auto Compression  |
| 7. | Incline/Decline   |

- |     |                 |
|-----|-----------------|
| 8.  | Power Button    |
| 9.  | Glute Knead     |
| 10. | Zero-G          |
| 11. | Auto Back Knead |
| 12. | Foot Knead      |
| 13. | Heat            |
| 14. | Auto Program    |

## Remote Control Function

Power Button	<p><b>Power On:</b> Press once to turn the chair on. The chair will move to default recline position and start Auto Program (A) F1.</p> <p><b>Power Off:</b> Press and hold to turn the chair off. After pressing the switch button to turn off the power, all programs, including heating and airbag functions, will turn off.</p> <p><b>Time Adjustment:</b> To change the workout time of the program, press the power button and it will increase it by 5 minutes. Maximum setting time is 30 minutes. Setting past 30 minutes will turn off the display and will need you to turn it back on.</p>
Compression Control – Arms, Upper & Lower back, Legs	<p>Air compression bags for the Arms, Upper &amp; Lower back, Legs.</p> <p>Pressing on the air bag icons once will turn it on and to turn it off press it again.</p>
Air Pressure Up/Down	<p>Adjusts the air pressure of the corresponding air compression bags for Arms, Upper/Lower back and Legs.</p>
Knead Control – Upper and Lower back	<p><b>Upper back</b> – Press once to turn on and press again to turn off. The knead function is for upper back only.</p> <p><b>Lower back</b> – Press once to turn on and press again to turn off. The knead function is for lower back only.</p>
Rotation Icon	<p>Changes the rotation for the knead function clockwise and counter-clockwise.</p> <p>Upper Back – appears as A1, A2, A3</p> <p>Lower Back – appears as B1, B2, B3</p>
Speed Up/Down	<p>Increases or decreases the speed for the knead function. There are only 3 levels – Low, Medium and High.</p>
Auto Compression On/Off	<p>Press once to turn on all the air compression functions. Press once more to turn it off.</p>
Incline/Decline	<p>Press and hold the <b>Incline</b> button to incline the chair.</p> <p>Press and hold the <b>Decline</b> button to decline the chair.</p>
Glute Knead	<p>Press once to turn on glute knead and press again to turn it off.</p>
Zero-G	<p>Press once to adjust the chair to a fully recline position. Press again to reset the chair to default position.</p>
Back Knead On/off	<p>Press once to turn on all the knead control. Press once more to off all knead control.</p> <p><i>This function does not turn off the foot or glute knead, use the respective button to turn them off.</i></p>
Foot Knead	<p>Press once to turn on the foot knead. Press once more to turn it off.</p>
Heat	<p>Press once to turn on heat for the calves and lower back. Press it once more to turn it off.</p>

Auto Program	<p>When Auto program is pressed the first program starts with a 15 minutes countdown. If you change the program it will continue from the time of the previous program. Increase the time using the power button, maximum setting is 30 minutes.</p> <p>Press once to turn on the program and to change to the program you wish to use. To get out of Auto Program, you can turn off the knead and air bags separately or using the ON/OFF for the Compression and Knead to turn it off at once.</p> <p>The program will automatically shut down after completing its countdown.  Note: Heat function is not used in auto program and must be turned on and off separately.</p> <p><b>Program Description:</b></p> <p>(A) <b>F1:</b> Turns on the upper and lower back knead, foot knead, and all compression bags are turned on. Glute Knead is not turned on. Default speed is 3 and intensity 1. You can manually change the levels for speed and intensity.</p> <p>(B) <b>F2:</b> All functions are active for upper and lower back knead, foot knead, glute knead and all compression bags. Default speed is 3 and intensity 1. You can manually change the levels for speed and intensity.</p> <p>(C) <b>F3:</b> All Airbags are turned on, as well as the neck and back functions are active, while other areas are inactive (feet and glute). Default speed is 3 and intensity 1. You can manually change the levels for speed and intensity.</p> <p>(D) <b>F4:</b> Upper and lower knead functions are active only. Default speed is 3.</p> <p>(E) <b>F5:</b> All airbags are active only. Default intensity is set as level 2.</p>
--------------	--

## Remote Control Function

button to turn on. Auto mode program (A) F1 will begin.

manually turn on or off the knead or air compression functions manually or navigate to program. Turning them all off will display Manual mode on the display and users can turn functions to turn back on.

increased by 5 minutes when pressing the Power button each time. NOTE: maximum is 30 minutes. After pressing past 30 minutes the display will turn off. You will need to turn the display

intensity, incline and recline can be adjusted to your preference.

to use heat it must be manually turned on and off.

Power button to turn off.



## VII. STORAGE

- Keep the massage chair free of dust.
- Cover the chair with a dust-free cloth to prevent dust from collecting.
- Do not store it in a hot, humid, or damp place, or in direct sunlight or heat. This may cause the colour of the upholstery to fade.
- Store indoors in a well-ventilated room.

## VIII. MAINTENANCE

- Before cleaning, unplug the chair from the electrical source to avoid electric shock.
- Clean the cloth surface with a neutral detergent or a special mild detergent for fabric.
- Dust can be cleaned off with a damp cloth and mild detergent, then air dry.
- Do not spray pesticide on the device.
- A specified cleaner can be used on the leather and plastic parts, and then dried with a cloth.
- Do not use a damp cloth on the electronic components, as this can cause shock and damage.
- The leather covers (headrest, seat cushion, foot cushion) can be removed for cleaning.
- Do not iron the upholstery.

# IX. TROUBLESHOOTING

Problem/Issue	Possible Cause	Troubleshooting Steps
Sounds like tapping or humming sounds	These are sounds from the air pump, motor, or other mechanical parts.	Normal phenomenon.
Suddenly stops working	<ol style="list-style-type: none"> <li>1. Bad power connection.</li> <li>2. Auto program timer is up.</li> </ol>	<ol style="list-style-type: none"> <li>1. Unplug and reinsert power cord to the chair.</li> </ol>
Not turning on when plugged to power	<ol style="list-style-type: none"> <li>1. The power switch is not turned on.</li> <li>2. Bad connection between plug and socket</li> <li>3. Massage remote is not turned on.</li> <li>4. Power plug is damaged.</li> <li>5. Issue with fuse.</li> <li>6. Check control unit if it is operational.</li> </ol>	<ol style="list-style-type: none"> <li>1. Turn on the power switch.</li> <li>2. Connect the power cord to another socket.</li> <li>3. Press the power button on the remote control.</li> <li>4. Replace the fuse.</li> <li>5. Contact the place of purchase for technical support.</li> </ol>
Roller height keeps changing	Rollers working alternately.	Normal phenomena.
Sudden abnormal sounds while in use	<ol style="list-style-type: none"> <li>1. Chair is being overused.</li> </ol>	<ol style="list-style-type: none"> <li>1. Cut down on usage.</li> <li>2. Contact place of purchase for technical support.</li> </ol>
Chair is not reclining	<ol style="list-style-type: none"> <li>1. Obstruction: Ensure there is enough space to fully recline.</li> </ol>	<ol style="list-style-type: none"> <li>1. Stop chair operation and remove obstruction.</li> </ol>
Chair cannot be reset from recline position	<ol style="list-style-type: none"> <li>1. Issue with the electric motion pole or plug has poor connection.</li> </ol>	<ol style="list-style-type: none"> <li>1. Contact the place of purchase for technical support.</li> </ol>

# X. WARRANTY

## AUSTRALIAN CONSUMER LAW

Many of our products come with a guarantee or warranty from the manufacturer. In addition, they come with guarantees that cannot be excluded under the Australian Consumer Law. You are entitled to a replacement or refund for a major failure and compensation for any other reasonably foreseeable loss or damage.

You are entitled to have the goods repaired or replaced if the goods fail to be of acceptable quality and the failure does not amount to a major failure. Full details of your consumer rights may be found at [www.consumerlaw.gov.au](http://www.consumerlaw.gov.au).

Please visit our website to view our full warranty terms and conditions:  
<http://www.lifespanfitness.com.au/warranty-repairs>

## WARRANTY AND SUPPORT

Any claim against this warranty must be made through your original place of purchase. Proof of purchase is required before a warranty claim may be processed.

If you have purchased this product from the Official Lifespan Fitness website, please visit <https://lifespanfitness.com.au/warranty-form>

For support outside of warranty, if you wish to purchase replacement parts or request a repair or service, please visit <https://lifespanfitness.com.au/warranty-form> and fill in our Repair/Service Request Form or Parts Purchase Form.

Scan this QR code with your device to go to [lifespanfitness.com.au/warranty-form](https://lifespanfitness.com.au/warranty-form)







[WWW.LIFESPANFITNESS.COM.AU](http://WWW.LIFESPANFITNESS.COM.AU)