

SH-500 Pegboard Standalone

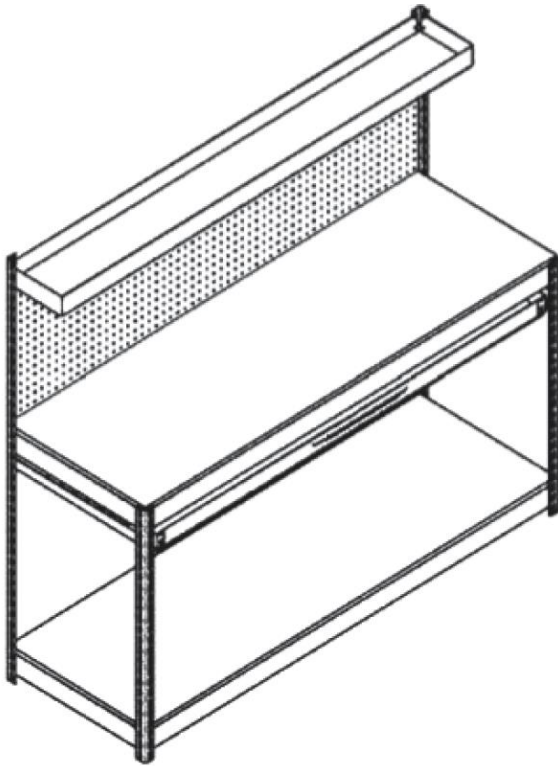

WARNING

- This unit should be placed on a level surface. Failure to do so can result in poor product performance or create a possible safety hazard.
- This unit should be securely anchored to a wall or floor with suitable fasteners that are included.
- Do not use this unit for anything other than its intended purpose.
- Do not stand on any part of the unit or use it as a ladder.
- Evenly distribute the weight on each level and always keep the heavier loads on the bottom shelf.
- Use care when working with metal parts.

General Instructions

Assembly is done with the rivets of the beams and braces fitting into the slots of the post. A rubber mallet may be used on the beams and braces to seat the rivet properly. A hammer can also be used, providing one uses a cloth or a block of wood between the hammer head and the parts to prevent damage. Tap gently and be sure the rivets are straight and fully engaged.

Required Tools

- Rubber mallet
- Phillips Screwdriver
- Wrench

Qty	Description	Part #
1	Top Right Back Post (914mm)	SU4K12
1	Top Left Back Post (914mm)	SU4K13
2	Bottom Back Post (975mm)	SU4K14
2	Front Post (889mm)	SU4K15
4	Braces(435mm)	SU4K2
4	Beams (892mm)	SU4K1
1	Top Left Extension Support (229mm)	SU4K16
1	Top Right Extension Support (229mm)	SU4K17
2	Top Shelf Flat Beam (889mm)	SU4K18
1	Left Drawer Mount	SU4K19
1	Right Drawer Mount	SU4K20
1	Left Drawer Slide	SU4K21
1	Right Drawer Slide	SU4K22
1	Front Drawer Shelf Brace (787mm)	SU4K23
1	Back Drawer Shelf Brace (787mm)	SU4K24
2	Steel Peg Board (467 x 908mm)	SU4K25
2	Laminate Shelves (467 x 902mm)	SU4K10
1	Laminate Drawer Shelf (298 x 787mm)	SU4K26
1	Laminate Top Shelf (229 x 902mm)	SU4K27
8	Nuts, Bolts	n/a
1	Handle	SU4K28

Assembly Instructions

1. Take one 975mm bottom back post (top end has a half slot hole) and one 965mm top right back post (top has slot holes, bottom has rivets) and create a coupled back post.

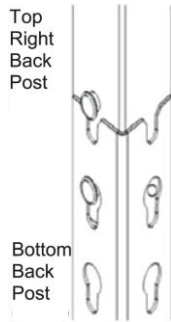

2. Take one 435mm brace (shelf ledge up) and one 889mm front post and attach the rivets of the brace to the top two holes of the front post.

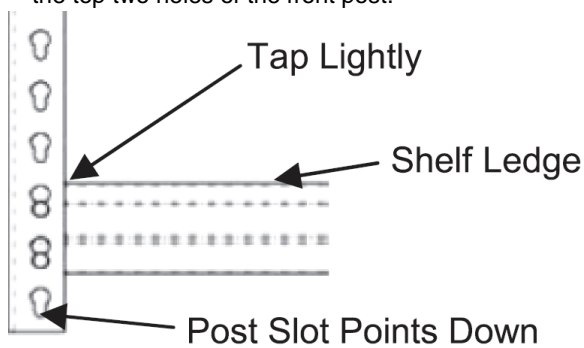

3. Take the coupled back post and attach the opposite rivets to the holes so the brace is level. Tap brace down to seat.
4. Attach the bottom 435mm brace to the front post, skipping one hole from the bottom, and the opposite end level to the coupled back post. Tap brace down to seat.
5. Take one drawer mount and insert the rivets two slot holes below the 435mm top brace on both ends and tap to seat.
6. Repeat steps for the opposite end assembly.

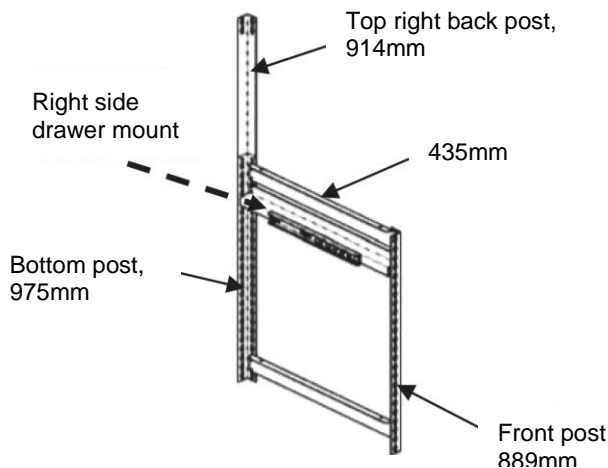

7. Take four 892mm beams with the shelf ledge facing up and attach two even with the end assembly's bottom braces and two even with the braces at the top.
8. Install one back 889mm flat beam with the bend facing down to the top holes of the top back posts.
9. Take the two support extensions and install one 889mm flat beam with the bend facing down to the front holes of the top support extensions to create the top shelf assembly.
10. Take the support extension's rivets of the assembly and install the top shelf assembly even with the rivets of the 889mm back flat beam of the unit.

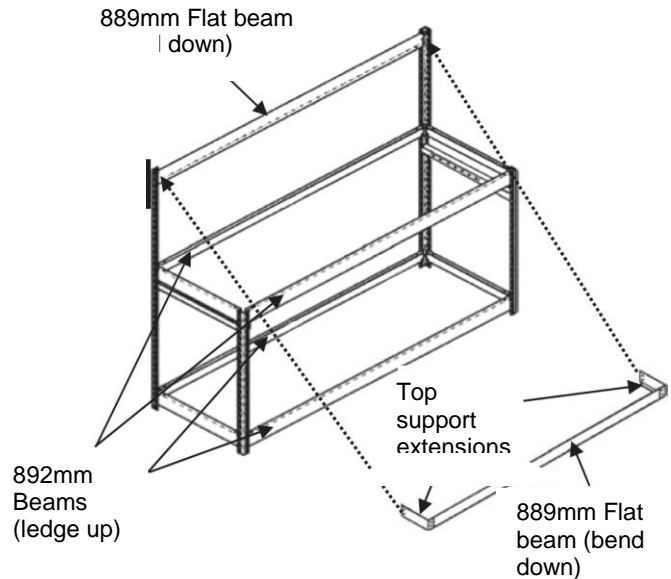

11. Assemble the top post to the bottom post by using two beams and two braces.
12. One rivet from each beam and brace must be placed in the top slot hole of the bottom post, and the bottom slot hole of the top post. After all beams and braces are in place, tap lightly to properly seat the rivets.
13. Add a laminate shelf to the previously built level, and then continue by adding the third and fourth level to the unit using two beams and two braces per level.

WARRANTY

AUSTRALIAN CONSUMER LAW

Many of our products come with a guarantee or warranty from the manufacturer. In addition, they come with guarantees that cannot be excluded under the Australian Consumer Law. You are entitled to a replacement or refund for a major failure and compensation for any other reasonably foreseeable loss or damage.

You are entitled to have the goods repaired or replaced if the goods fail to be of acceptable quality and the failure does not amount to a major failure. Full details of your consumer rights may be found at www.consumerlaw.gov.au

Warranty and Support:

Please email us at support@lifespanfitness.com.au for all warranty or support issues.

For all warranty or support related enquiries an email must be sent before contacting us via other means.

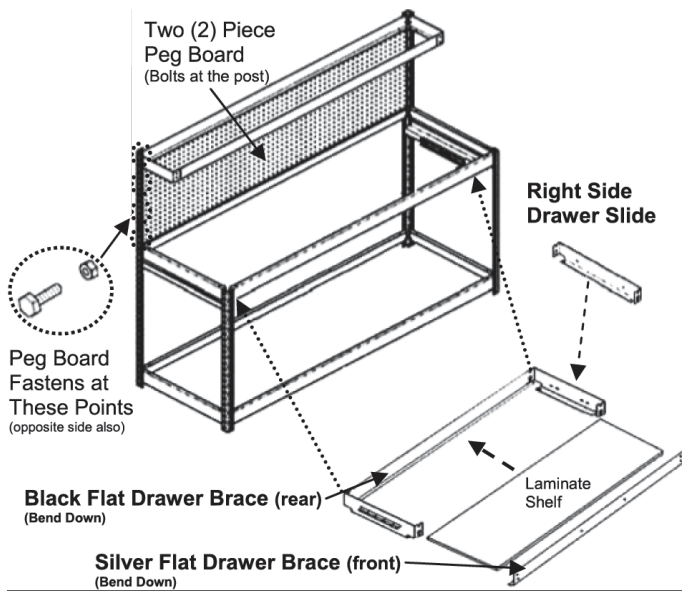

14. Tap lightly to properly seat the rivets and add the final laminate shelves and the handles to the drawers to finalize the assembly of the unit.
15. Optional anchor hardware is supplied with this unit so the unit can be fastened to a wall if necessary. See instructions for installing anchor hardware.

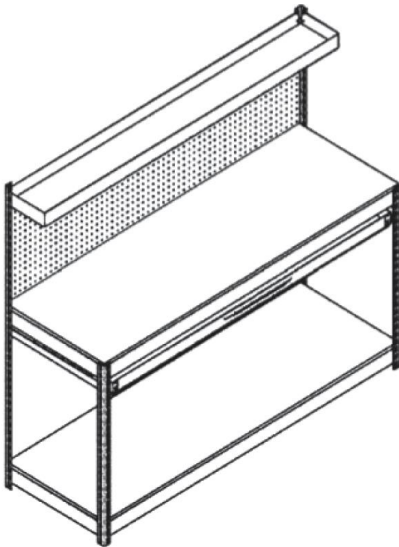

IMPORTANT

Make sure all rivets are seated properly into the post slots.