

# WTO2 OLYMPIC WEIGHT TREE OWNER'S MANUAL

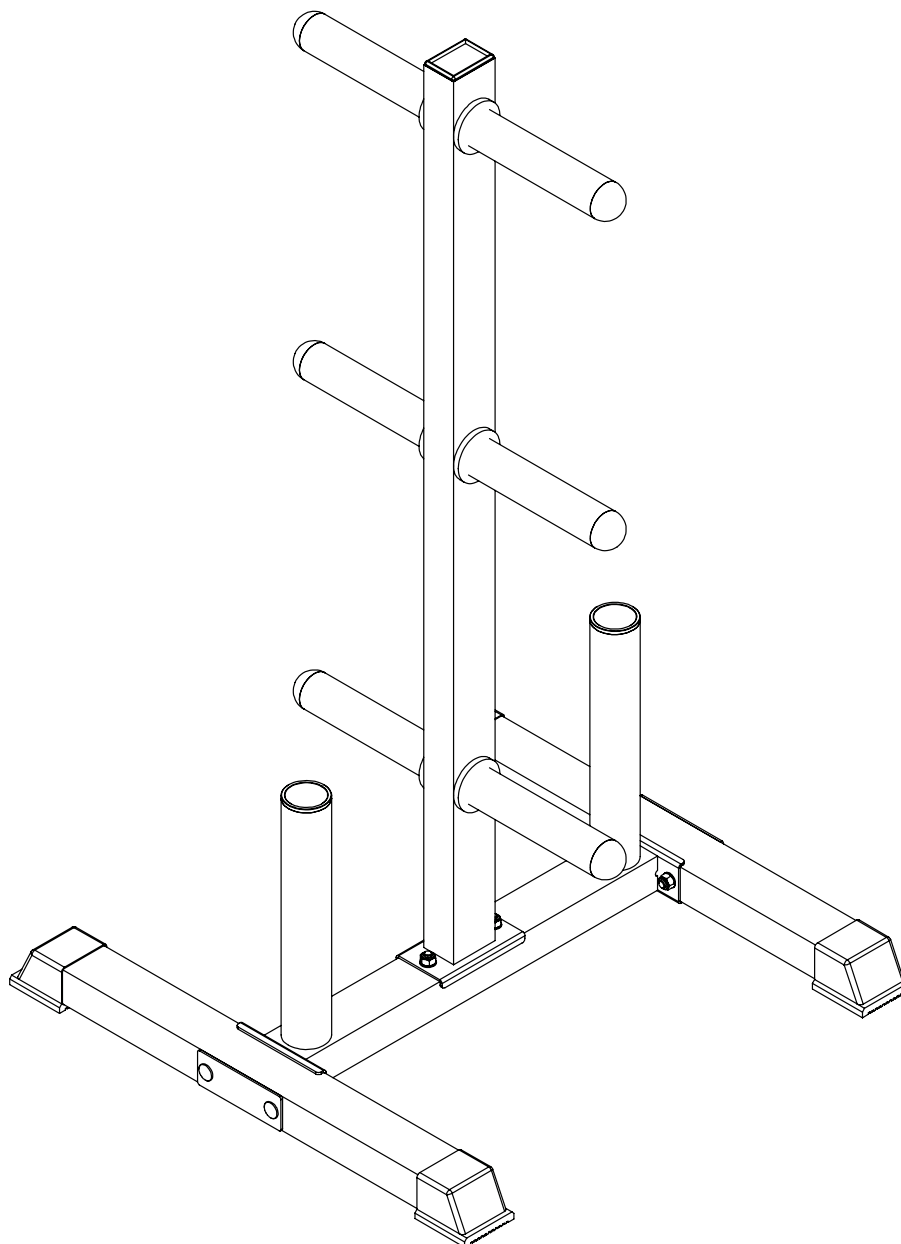

**Product may vary slightly from the item pictured due to model upgrades**

**Read all instructions carefully before using this product. Retain this owner's manual for future reference.**

# TABLE OF CONTENTS

1. IMPORTANT SAFETY INSTRUCTIONS	3
2. CARE INSTRUCTIONS	4
3. PARTS LIST	4
4. ASSEMBLY INSTRUCTIONS	5
5. WARRANTY	6

# 1. IMPORTANT SAFETY INSTRUCTIONS

**WARNING** - Read all instructions before using this product.

Please keep this manual with you at all times

- a. It is important to read this entire manual before assembling and using the equipment. Safe and effective use can only be achieved if the equipment is assembled, maintained and used properly. Please note: It is your responsibility to ensure that all users of the equipment are informed of all warnings and precautions.
- b. Before starting any exercise program you should consult your doctor to determine if you have any medical or physical conditions that could put your health and safety at risk, or prevent you from using the equipment properly. Your doctor's advice is essential if you are taking medication that affects your heart rate, blood pressure or cholesterol level.
- c. Be aware of your body's signals. Incorrect or excessive exercise can damage your health. Stop exercising if you experience any of the following symptoms: pain, tightness in your chest, irregular heartbeat, and extreme shortness of breath, lightheadedness, dizziness or feelings of nausea. If you do experience any of these symptoms, you should consult your doctor before continuing with your exercise program.
- d. Keep children and pets away from the equipment. This equipment is designed for adult use only.
- e. Use the equipment on a solid, flat level surface with a protective cover for your floor or carpet. To ensure safety, the equipment should have at least 2 meters of free space around it.
- f. Before using the equipment, check that the nuts and bolts are securely tightened. If you hear any unusual noises coming from the equipment during use and assembly, stop immediately. Do not use the equipment until the problem has been rectified.
- g. Wear suitable clothing while using the equipment. Avoid wearing loose clothing that may get caught in the equipment or that may restrict or prevent movement.
- h. This equipment is designed for indoor and family use only
- i. Care must be taken when lifting or moving the equipment so as not to injure your back.

- j. Always keep this instruction manual and assembly tools at hand for reference.
- k. The equipment is not suitable for therapeutic use.

## 2. CARE INSTRUCTIONS

- Lubricate moving joints with grease after periods of usage
- Be careful not to damage plastic or metal parts of the machine with heavy or sharp objects
- The machine can be kept clean by wiping it down using dry cloth

## 3. PARTS LIST

NO.	Name	Model	Quantity
1	Welded frame		1
2	Foot tube		2
3	Main tube		1
4	Bracket		3
5	Tube rubber sleeve		4
6	Tube plug		1
7	Tube plug		6
8	Washer	Φ10	6
9	Nut	M10	6
10	Carriage bolt	M10 x 90mm	4
11	Carriage bolt	M10 x 70mm	2
12	Rubber sleeve		6
13	Rubber bushing		2

## 4. ASSEMBLY INSTRUCTIONS

### STEP 1:

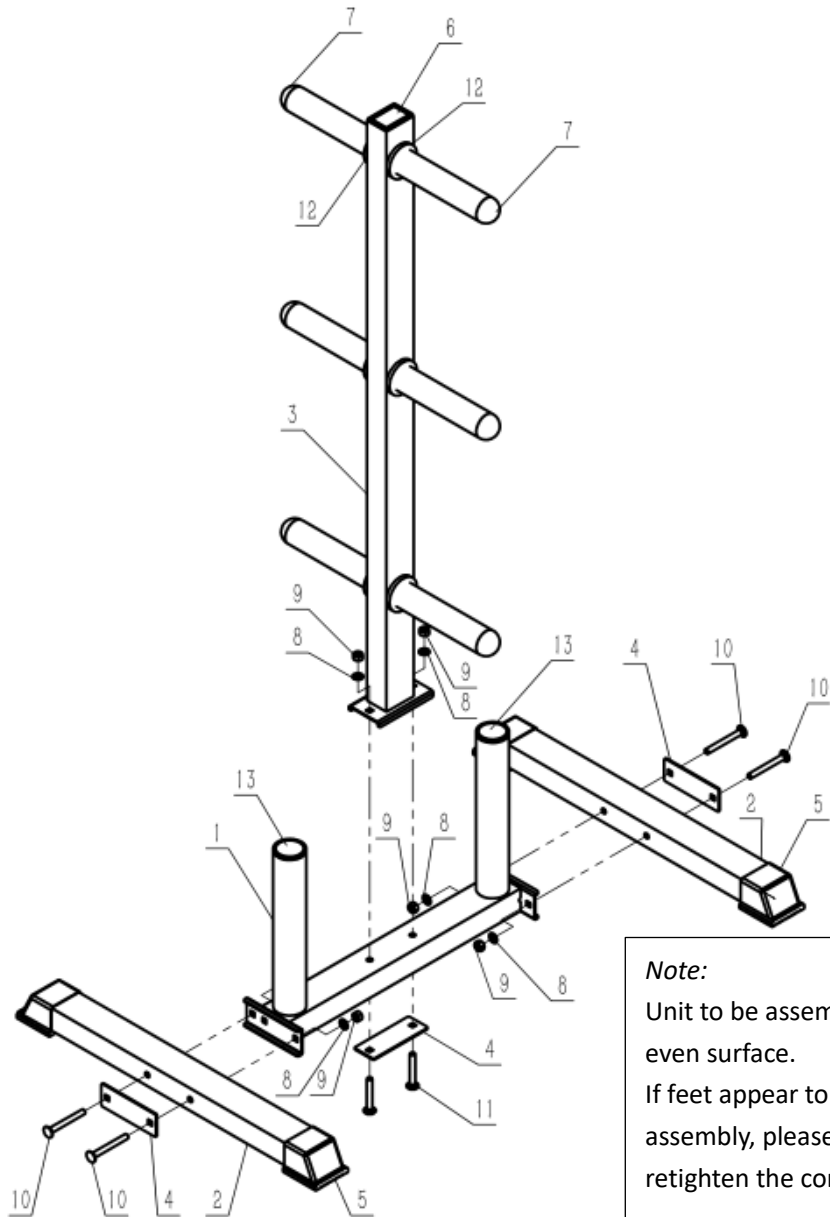

- a) Secure 1x Main Tube (#3) to the 1x Welded Frame (#1) with:
  - 2x Carriage Bolts M10 x 70mm (#11)
  - 2x Washers  $\Phi$ 10 (#8)
  - 2x Nuts M10 (#9)
  - 1x Bracket (#4)
- b) Secure 2x Foot tubes (#2) to 1x Welded Frame (#1) with:
  - 4x Carriage Bolts M10 x 90mm (#10)
  - 4x Washers  $\Phi$ 10 (#8)
  - 4x Nuts M10 (#9)
  - 2x Brackets (#4)

## 5. WARRANTY

### AUSTRALIAN CONSUMER LAW

*Many of our products come with a guarantee or warranty from the manufacturer. In addition, they come with guarantees that cannot be excluded under the Australian Consumer Law. You are entitled to a replacement or refund for a major failure and compensation for any other reasonably foreseeable loss or damage.*

*You are entitled to have the goods repaired or replaced if the goods fail to be of acceptable quality and the failure does not amount to a major failure. Full details of your consumer rights may be found at [www.consumerlaw.gov.au](http://www.consumerlaw.gov.au)*

Please visit our website to view our full warranty terms and conditions:

<http://www.lifespanfitness.com.au/warranty-repairs>

### **Warranty and Support:**

Please email us at [support@lifespanfitness.com.au](mailto:support@lifespanfitness.com.au) for all warranty or support issues.

For all warranty or support related enquiries an email must be sent before contacting us via any other means.