

CORTEX[®]

Parallel Bars A2 with Height and Width Adjustments

USER MANUAL

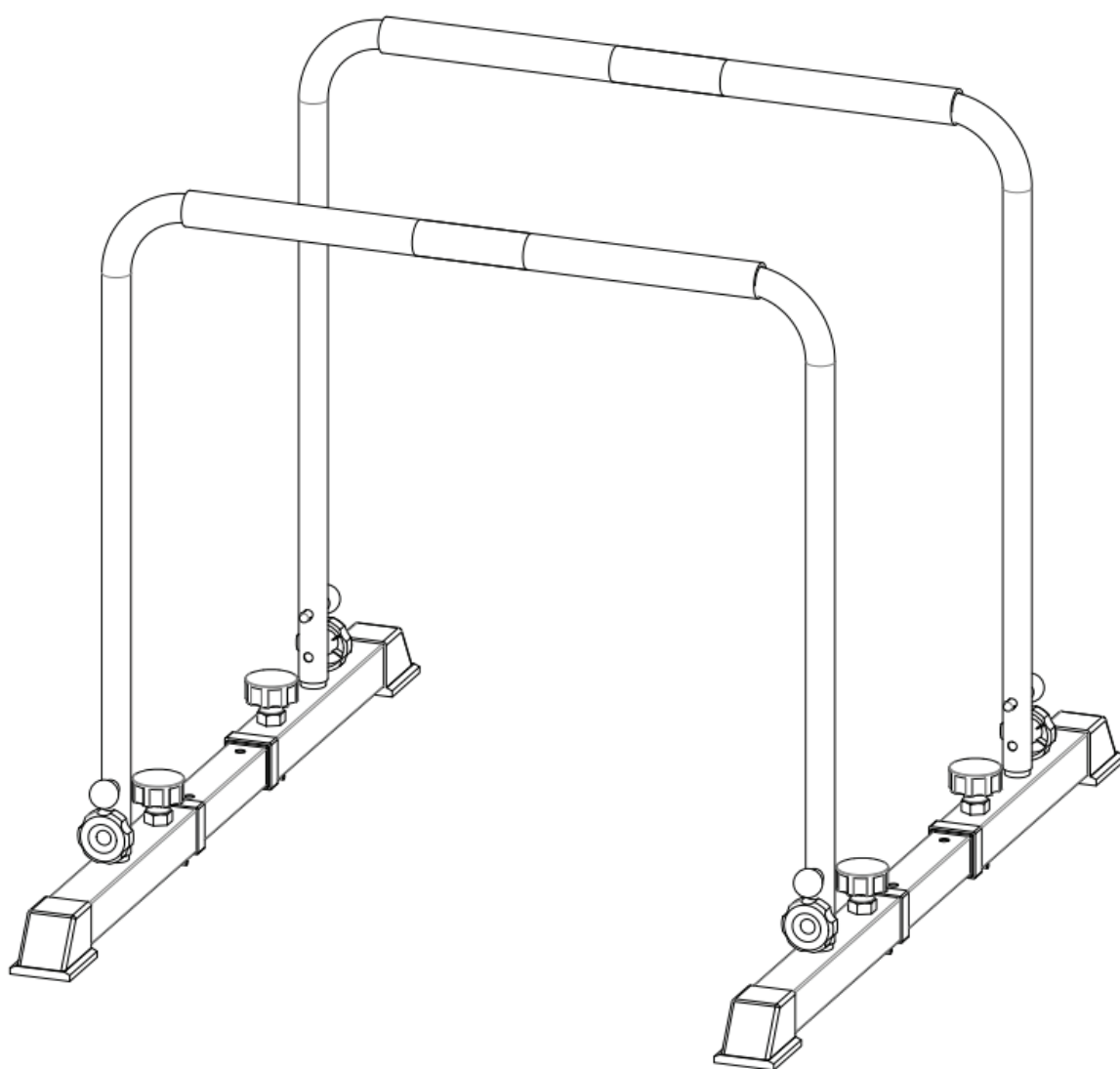

Product may vary slightly from the item pictured due to model upgrades.



**Read all instructions carefully before using this product.
Retain this owner's manual for future reference.**

NOTE:

This manual should not be used to guide your purchasing decision. Your product, and the contents inside its carton, may vary from what is listed in this manual. This manual may also be subject to updates or changes. Updated manuals are available through our website at www.lifespanfitness.com.au



TABLE OF CONTENTS

I. Important Safety Instructions	04
II. Maintenance Instructions	05
III. Parts List	06
IV. Assembly Instructions	07
V. Exercise Guide	08
VI. Warranty	10

I. IMPORTANT SAFETY INSTRUCTIONS

 **WARNING: Read all instructions before using this product.**

Please always keep this manual with you.

- This equipment is designed for indoor and family use only.
- The equipment is not suitable for therapeutic use.
- It is important to read this entire manual before assembling and using the equipment. Safe and effective use can only be achieved if the equipment is assembled, maintained, and used properly.
- **Please note:** It is your responsibility to ensure that all users of the equipment are informed of all warnings and precautions.
- Before starting any exercise program, you should consult your doctor to determine if you have any medical or physical conditions that could put your health and safety at risk, or prevent you from using the equipment properly. Your doctor's advice is essential if you are taking medication that affects your heart rate, blood pressure or cholesterol level.
- Be aware of your body's signals. Incorrect or excessive exercise can damage your health. Stop exercising if you experience any of the following symptoms: pain, tightness in your chest, irregular heartbeat, and extreme shortness of breath, lightheadedness, dizziness, or feelings of nausea. If you do experience any of these symptoms, you should consult your doctor before continuing with your exercise program.
- Keep children and pets away from the equipment. This equipment is designed for adult use only.
- Use the equipment on a solid, flat level surface with a protective cover for your floor or carpet. To ensure safety, the equipment should have at least 2 meters of free space around it.
- Before using the equipment, check that the nuts and bolts are securely tightened. If you hear any unusual noises coming from the equipment during use and assembly, stop immediately. Do not use the equipment until the problem has been rectified.
- Wear suitable clothing while using the equipment. Avoid wearing loose clothing that may get caught in the equipment or that may restrict or prevent movement.

II. MAINTENANCE INSTRUCTIONS

1. Check all moving parts regularly for signs of wear and damage, and you must stop using the device immediately and contact our sales back.
2. During the inspection, ensure all the knob pins are completely fixed. If the screw connection is loosened, please lock them before use.
3. Re-tighten any loose bolts.
4. Check the weld joint for cracks.
5. The machine can be kept clean by wiping it down using dry cloth.
6. Failure to perform routine maintenance may result in personal injury or damage to the device.

II. PARTS LIST

Part No.	Description	Qty
1	Main frame	4
2	Big frame	2
3	M10 knob	4
4	Ball head list pin	4
5	Pull pin	4
6	Adjustable tube	2

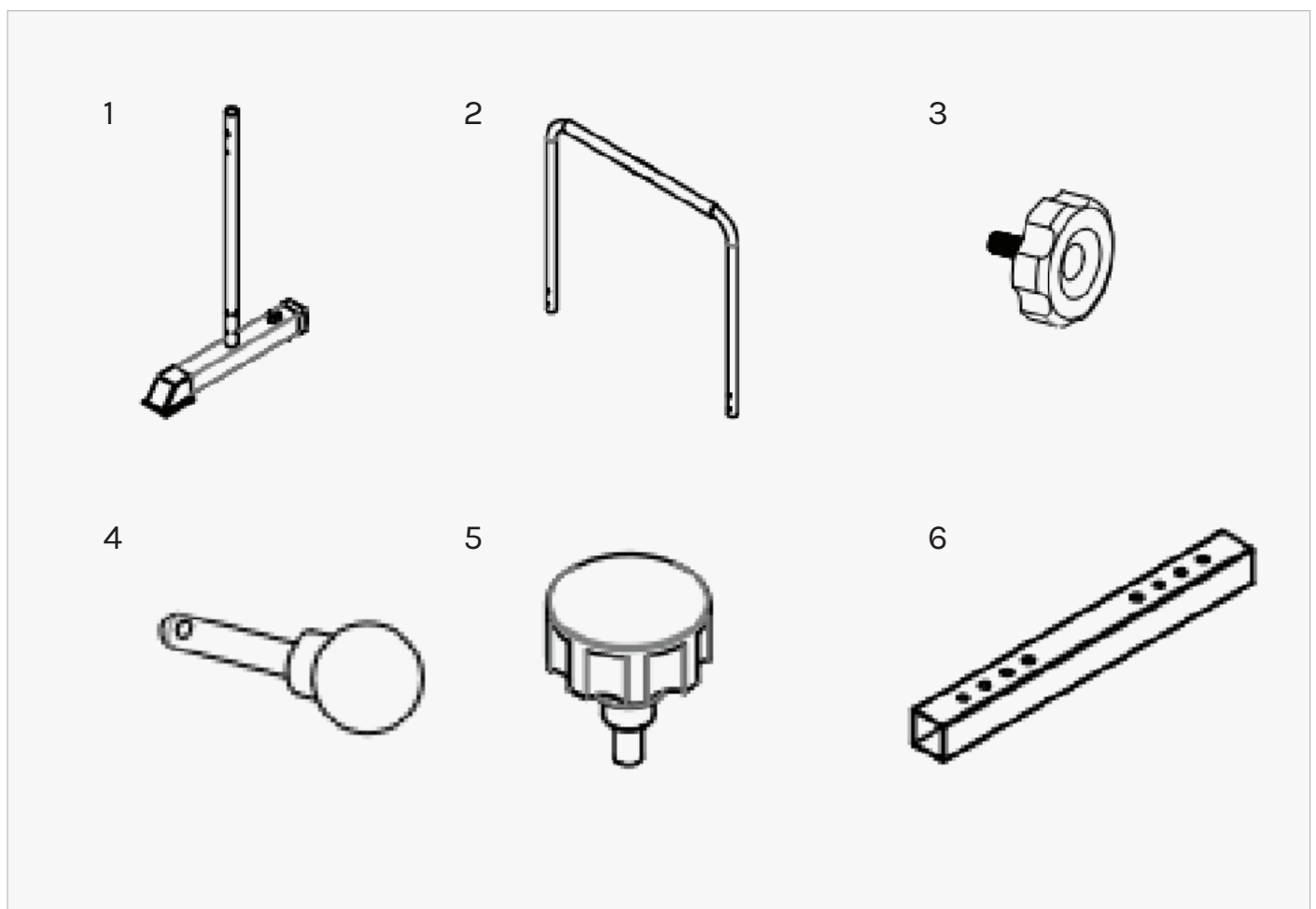

III. ASSEMBLY INSTRUCTIONS

Important:

1. The gasket should be placed at both ends of the bolt (anti-bolt head and nut), unless otherwise specified.
2. Preliminary assembly is to tighten all bolts and nuts by hand and tighten with wrench for complete assembly.
3. Some spare parts have been pre-assembled in the factory.

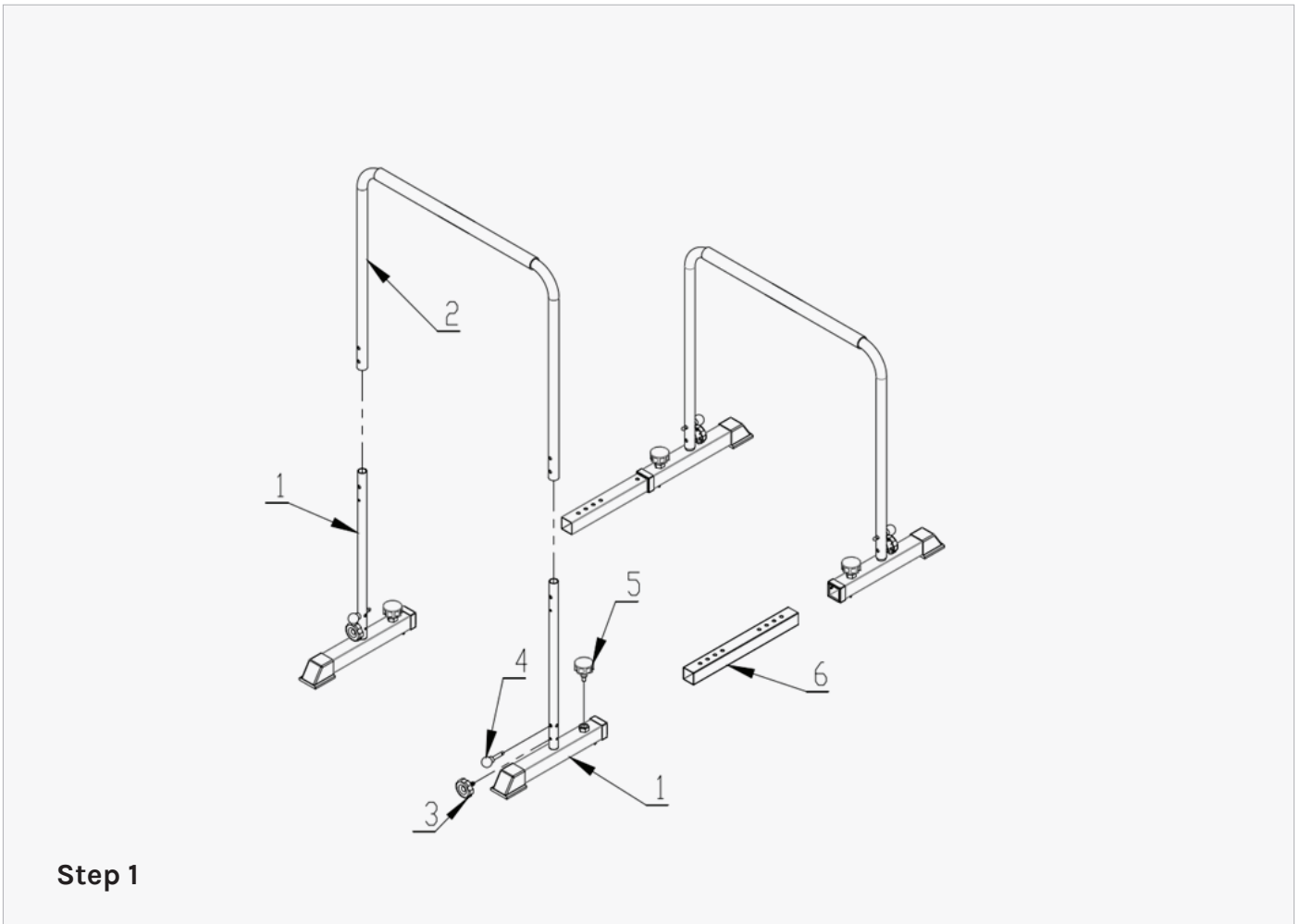

1. Install the base frame (# 1) under the large frame (# 2) according to the figure shown, and then tighten it with the M10 knob (# 3) and the ball head sheet pin (# 4). Repeat for the other side.
2. Install the adjusting tube (# 6) in the middle of the frame (# 1) and tighten it with a pull pin (# 5). Repeat for the other side.
3. You can adjust the height by securing to the 2x holes at the top of (# 1) or expand the width on part (# 6) tube.

V. EXERCISE GUIDE

ⓘ PLEASE NOTE:

Before beginning any exercise program, consult your physician. This is important especially if you are over the age of 45 or individuals with pre-existing health problems.

The pulse sensors are not medical devices. Various factors, including the user's movement, may affect the accuracy of heart rate readings. The pulse sensors are intended only as an exercise aid in determining heart rate trends in general.

Exercising is a great way to control your weight, improve your fitness and reduce the effect of aging and stress. The key to success is to make exercise a regular and enjoyable part of your everyday life.

The condition of your heart and lungs and how efficient they are in delivering oxygen via your blood to your muscles is an important factor to your fitness. Your muscles use this oxygen to provide enough energy for daily activity. This is called aerobic activity. When you are fit, your heart will not have to work so hard. It will pump a lot fewer times per minute, reducing the wear and tear of your heart.

So as you can see, the fitter you are, the healthier and greater you will feel.

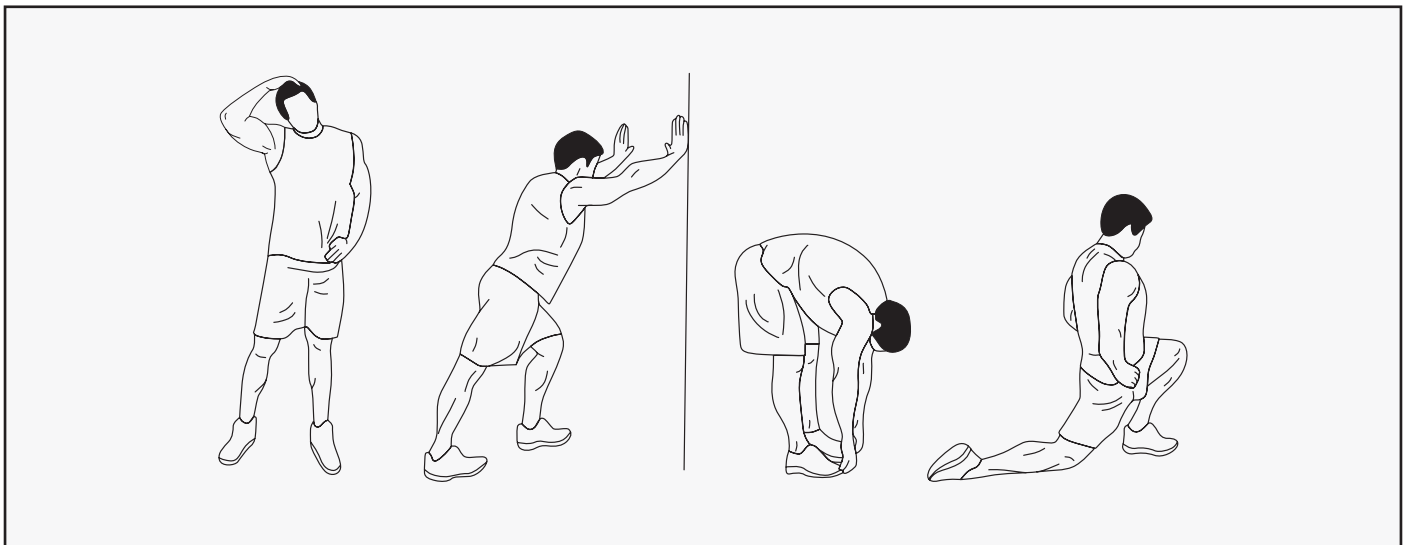

WARM UP

Start each workout with 5 to 10 minutes of stretching and some light exercises. A proper warm-up increases your body temperature, heart rate and circulation in preparation for exercise. Ease into your exercise.

After warming up, increase the intensity to your desired exercise program. Be sure to maintain your intensity for maximum performance. Breathe regularly and deeply as you exercise.

COOL DOWN

Finish each workout with a light jog or walk for at least 1 minute. Then complete 5 to 10 minutes of stretching to cool down. This will increase the flexibility of your muscles and will help prevent post-exercise problems.

WORKOUT GUIDELINES

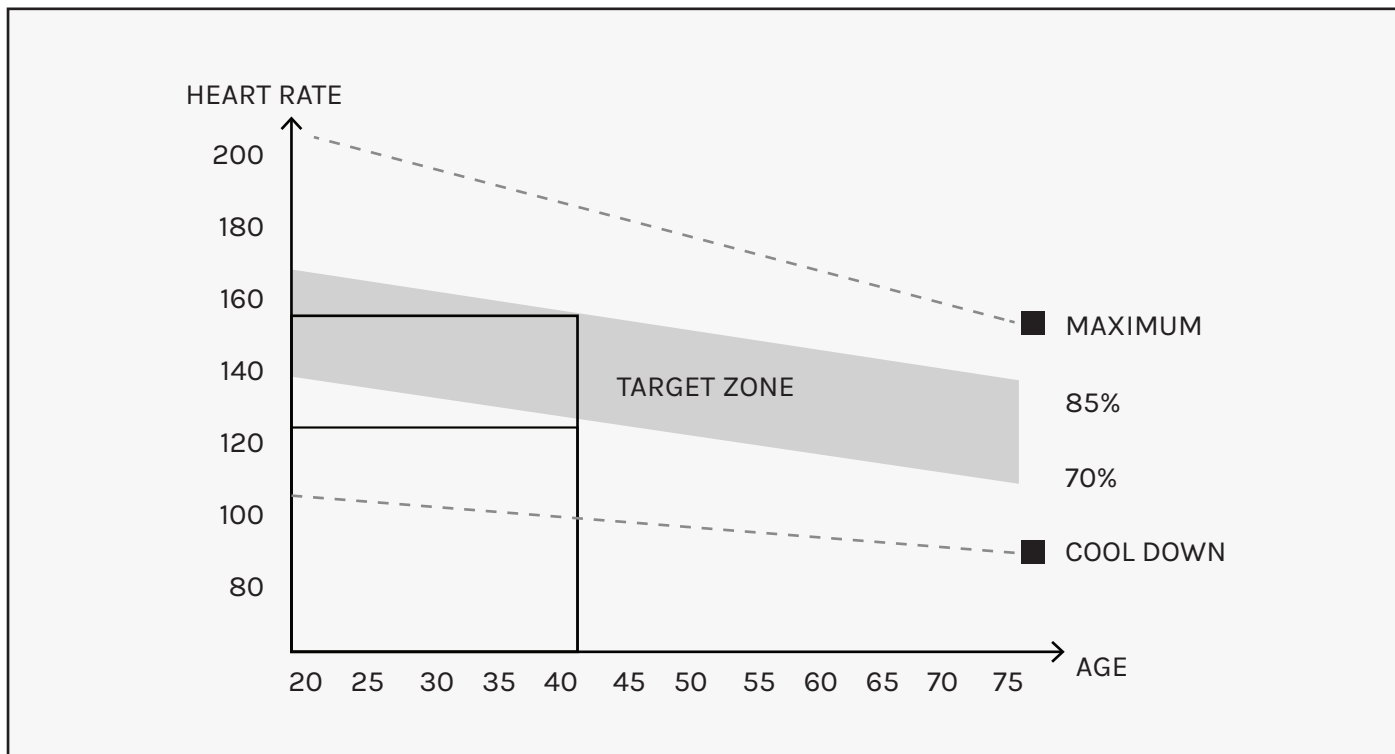

⚠ This is how your pulse should behave during general fitness exercise. Remember to warm up and cool down for a few minutes.

The most important factor here is the amount of effort you put in. The harder and longer you work, the more calories you will burn.

VI. WARRANTY

AUSTRALIAN CONSUMER LAW

Many of our products come with a guarantee or warranty from the manufacturer. In addition, they come with guarantees that cannot be excluded under the Australian Consumer Law. You are entitled to a replacement or refund for a major failure and compensation for any other reasonably foreseeable loss or damage.

You are entitled to have the goods repaired or replaced if the goods fail to be of acceptable quality and the failure does not amount to a major failure. Full details of your consumer rights may be found at www.consumerlaw.gov.au.

Please visit our website to view our full warranty terms and conditions:
<http://www.lifespanfitness.com.au/warranty-repairs>

WARRANTY AND SUPPORT

Any claim against this warranty must be made through your original place of purchase. Proof of purchase is required before a warranty claim may be processed.

If you have purchased this product from the Official Lifespan Fitness website, please visit <https://lifespanfitness.com.au/warranty-form>

For support outside of warranty, if you wish to purchase replacement parts or request a repair or service, please visit <https://lifespanfitness.com.au/warranty-form> and fill in our Repair/Service Request Form or Parts Purchase Form.

Scan this QR code with your device to go to lifespanfitness.com.au/warranty-form



CORTEX[®]

WWW.LIFESPANFITNESS.COM.AU