

CORTEX[®]

SM25 Multi Gym

(Dual Stack Functional Trainer,
Smith Machine, Half Rack)

USER MANUAL

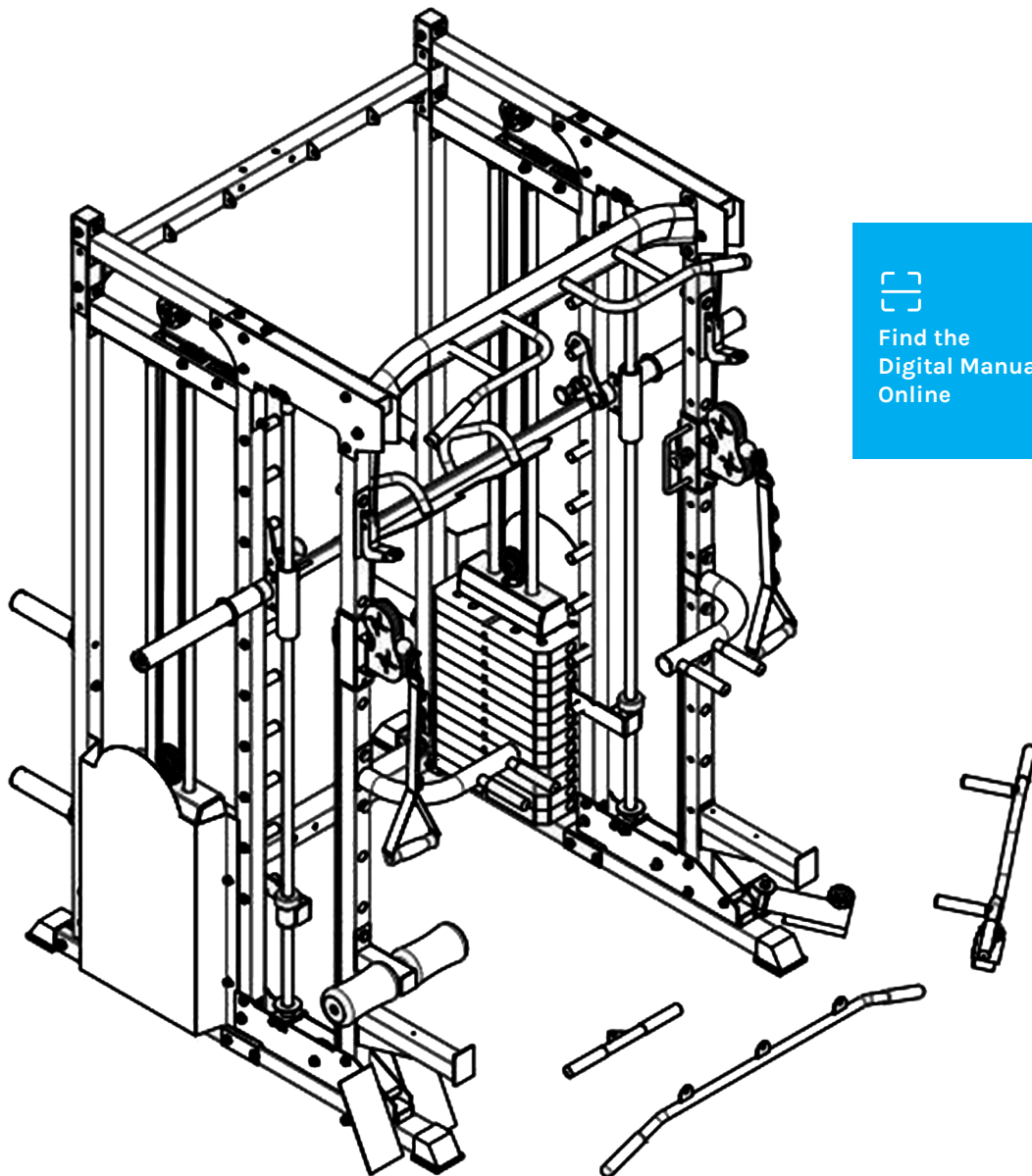

Find the
Digital Manual
Online



Product may vary slightly from the item pictured due to model upgrades.



**Read all instructions carefully before using this product.
Retain this owner's manual for future reference.**

NOTE:

This manual may be subject to updates or changes. Up to date manuals are available through our website at www.lifespanfitness.com.au



TABLE OF CONTENTS

I. Important Safety Instructions	03
II. Care Instructions	04
III. Parts List	05
IV. Assembly Instructions	08
V. Exercise Guide	28
VI. Maintenance	29
VII. Warranty	30

I. IMPORTANT SAFETY INSTRUCTIONS

 **WARNING: Read all instructions before using this machine.**

To ensure your safety, read the following precautions before using this product

1. Please read, study and understand the instructions and all warning labels before use.
(It is recommended to be familiar with the normal operation and use methods of the device before using this product. Information is available on this manual and at local retailers).
2. Please keep this manual and ensure that all the warning labels are clear and complete.
3. This product is recommended to install by more than two people.
4. Please consult your doctor's advice before starting the exercise.
5. Please ensure safety when the children are present.
6. Be careful when using it with children present.
7. Please check any signs of wear of the wire rope regularly. If there is wear, it may cause some danger to you.
8. Please keep your hands, limbs and clothes stretch to use the device.
9. Please note any signs of machinery that may occur, including part wear, loose hardware, and welding cracks. Stop using the device with the above signs immediately and contact the after-sales service department of our company.
10. You can complete the assembly with a wrench, or an inner hexagon wrench.
11. The user weight of this product shall not exceed 100kg.
12. The product is subject to change without notice and the final interpretation belongs to the Division.

II. CARE INSTRUCTIONS

- Lubricate moving joints with silicon spray after periods of usage.
- Be careful not to damage plastic or metal parts of the machine with heavy or sharp objects.
- The machine can be kept clean by wiping it down using dry cloth.
- Check and adjust the tension of wire rope on a regular basis.
- Regularly check all moving parts and make sure there are signs of wear and damage, if any the use of the device must be stopped immediately and contact our after-sales department.
- During inspection, it is necessary to make sure that all bolts and nuts are completely fixed. If any bolt or nut connection is loosened, please re-tighten.
- Check weld for cracks.
- Failure to perform daily maintenance may result in personal injury or equipment damage.

III. PARTS LIST

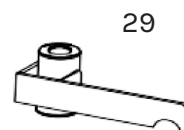
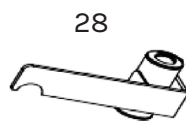
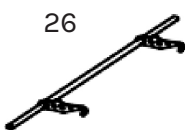
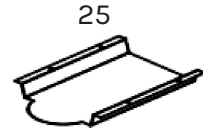
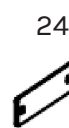
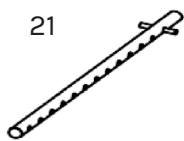
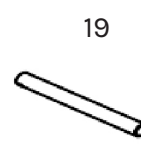
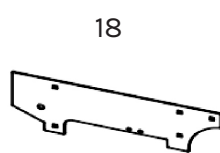
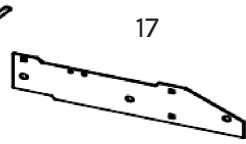
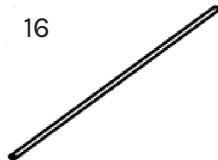
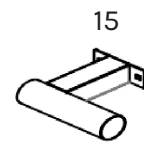
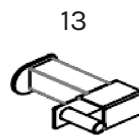
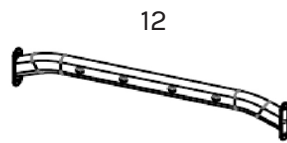
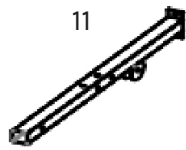
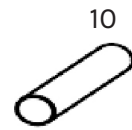
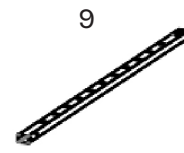
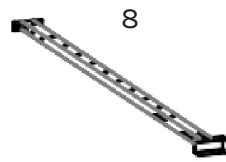
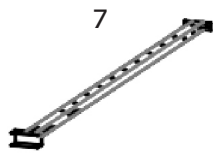
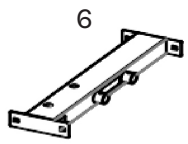
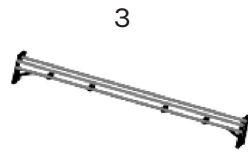
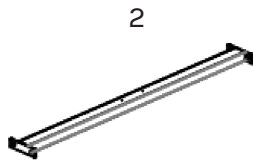
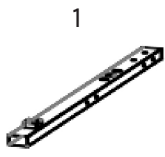

31



32

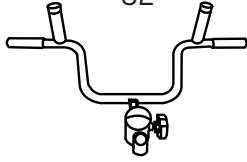

33

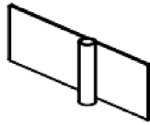

34



35

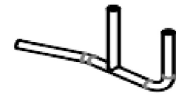

36

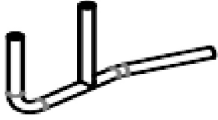

37



39

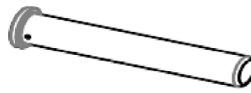

40



41



42

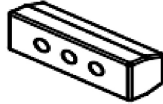

43

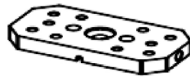

44

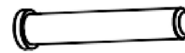

45



46



47



48



20.5mm - 8 qty.

49



15.5mm - 12 qty.

50



External Diameter
28mm - 2 qty.

51

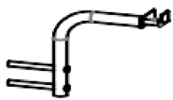

52



53



54



55



56

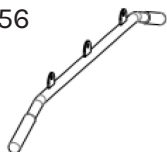

57



58



59



60



1pc M10 Knob

61



62



63



70



M10 x 95mm - 4 qty.

71

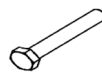

M10 x 90mm - 5 qty.

73

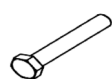

M10 x 75mm - 10 qty.

74

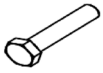

M10 x 70mm - 38 qty.

77



M10x45mm - 8 qty.

78



M8x16mm - 8 qty.

79



M10 x 20mm - 33 qty.
Some are pre-installed
on part 32

80

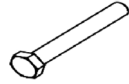

M10 x 110mm - 2 qty.

81

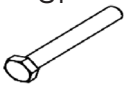

M8 x 80mm - 8 qty.

82



M8 x 35mm - 4 qty.

83



M10 - 71 qty.

84



M8 - 16 qty.

85



Φ 10 - 177 qty.

86



Φ 8 - 32 qty.

90



91



92



93



94

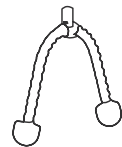

96



97

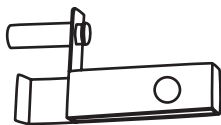

98





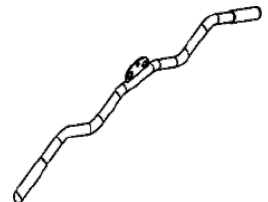

99



IV. ASSEMBLY INSTRUCTIONS

⚠ ATTENTION:

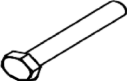
1. The gasket shall be placed at both ends of the bolts (against the bolt head and nuts), unless otherwise stated.
2. Preliminary assembly is hand tightening of all bolts and nuts and hand tightening with the wrench for complete assembly.
3. Some spare parts have been pre-assembled by the factory.
4. It is strongly recommended this machine to be assembled by two or more people to avoid possible injury

74		M10 x 70mm	4pcs	85		Φ 10	16pcs
70		M10 x 95mm	4pcs	83		M10	8pcs

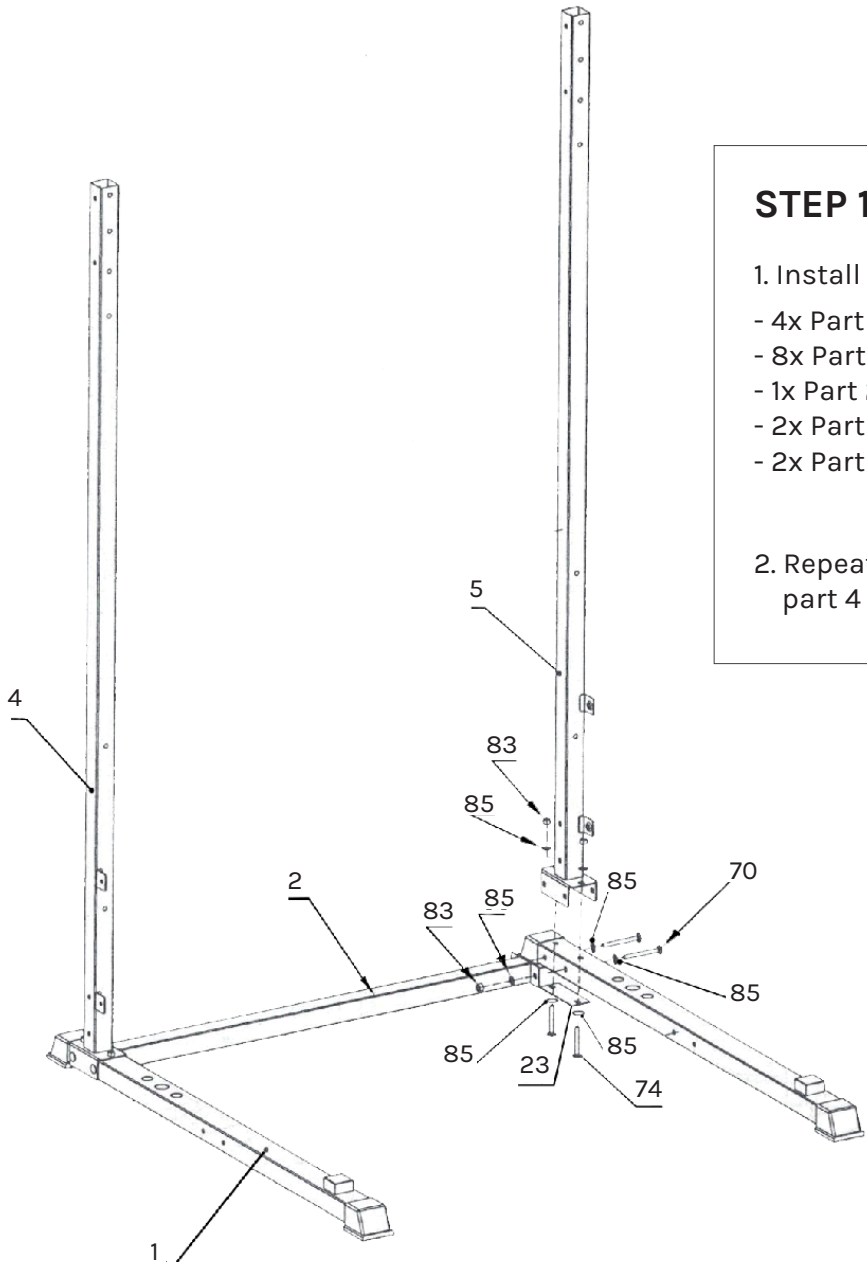

STEP 1

1. Install part 5 to part 1 and 2 using:

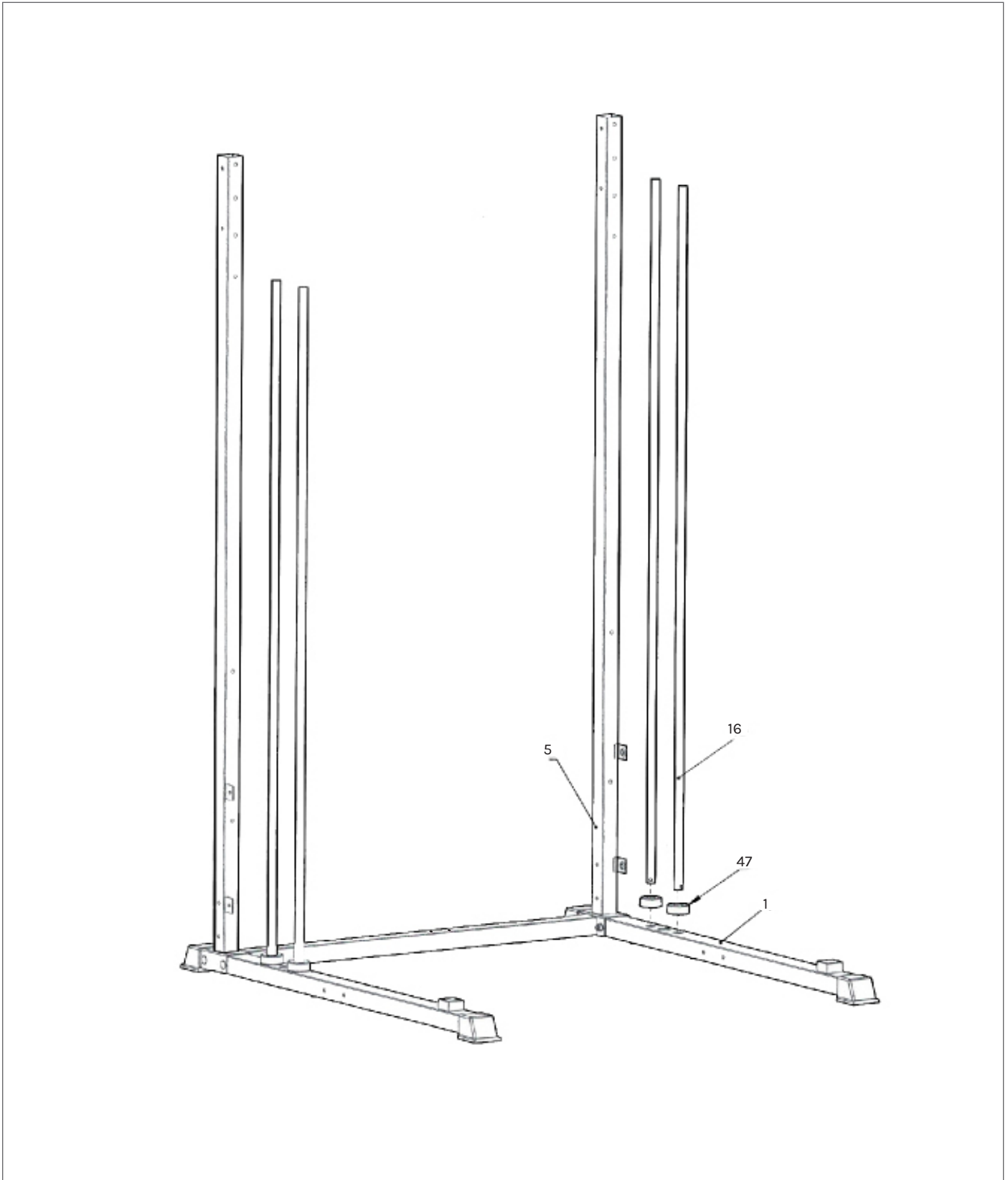

- 4x Part 83
- 8x Part 85
- 1x Part 23
- 2x Part 74
- 2x Part 70

2. Repeat same steps for connecting part 4 to parts 1 and 2.

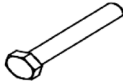

STEP 2

1. Place 4 x part 47 and 4 x part 16 into part 1 as pictured.

71		M10 x 90mm	4pcs
85		Φ 10	8pcs
83		M10	4pcs

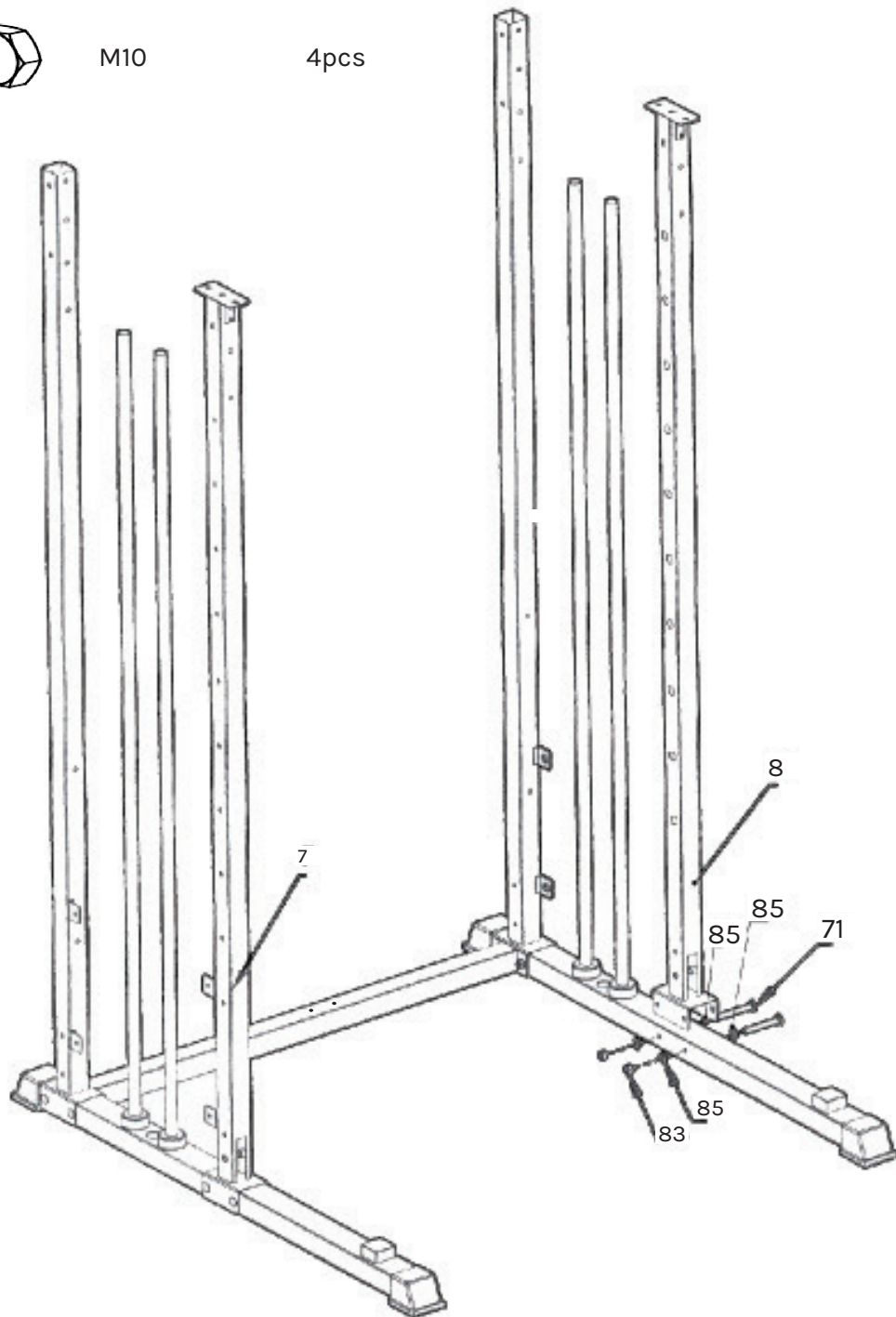

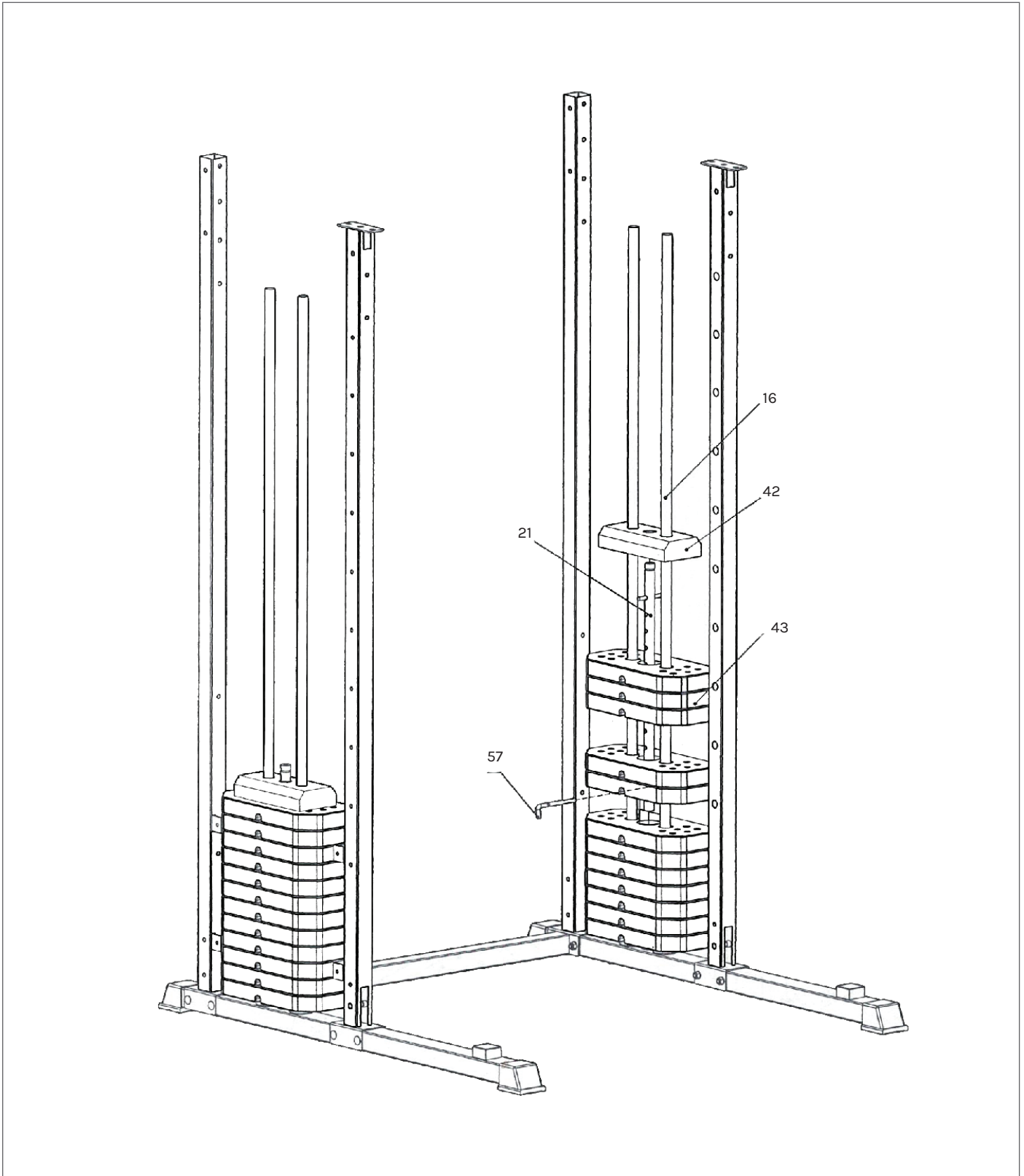

STEP 3

1. Install part 7 and part 8 using:
 - 4x part 71
 - 8x part 85
 - 4x part 83

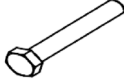

STEP 4

- 1. Insert the weight stacks part 43 into part 16 as pictured with the holes facing down.
- 2. Insert part 21 into the middle, through the weight stacks.
- 3. Lastly add the part 42 weight on top of the other weight stacks as pictured.
- 4. Insert part 57 to choose your desired weight load. Make sure it goes into the hole for part 21.

74		M10 x 70mm	4pcs
85		Φ 10	8pcs
83		M10	4pcs

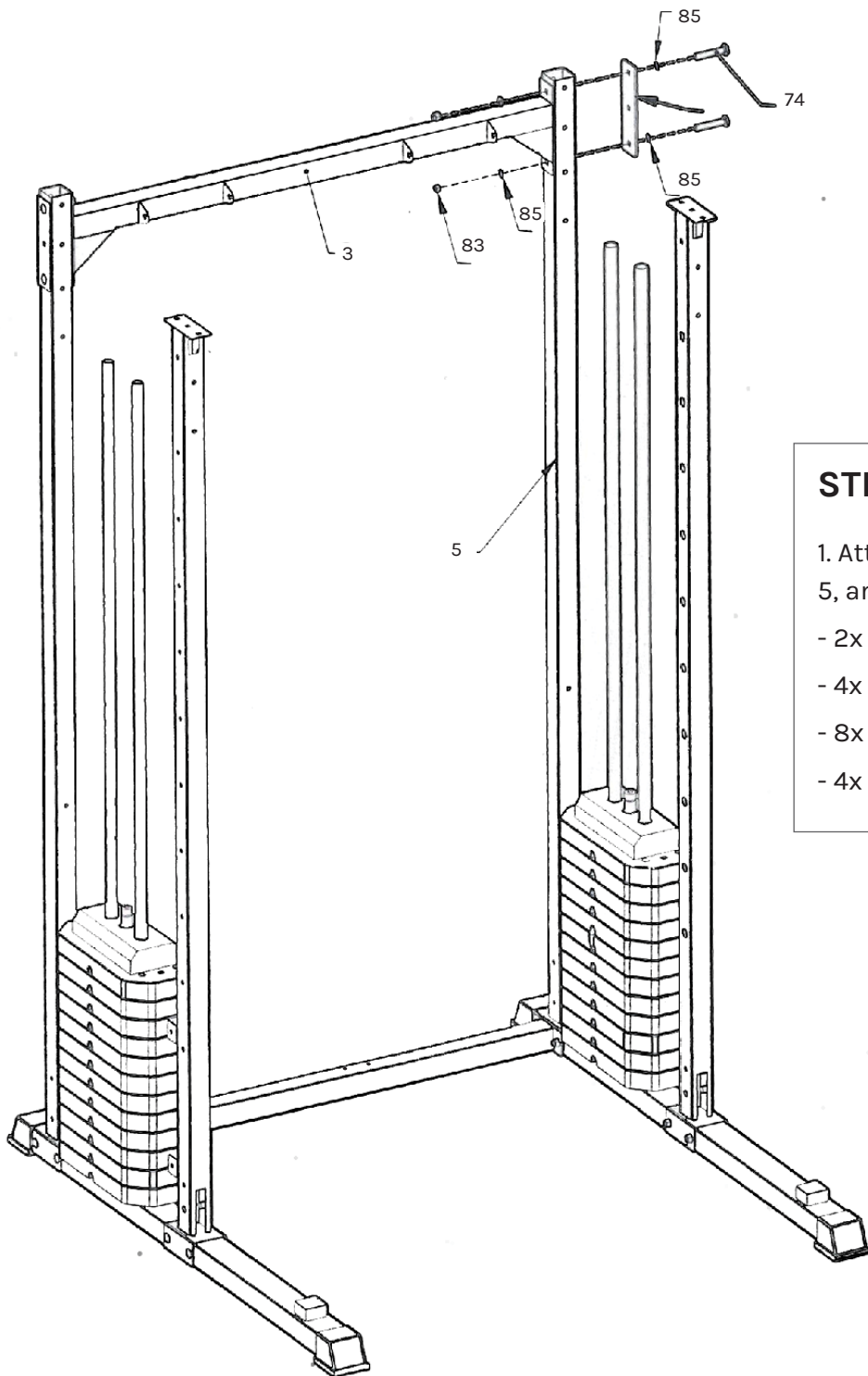

STEP 5

1. Attach part 3 to part 4 and 5, and secure it with:

- 2x part 24
- 4x part 74
- 8x part 85
- 4x part 83

74  M10 x 70mm 2pcs

85  $\Phi 10$ 8pcs

79  M10 x 15mm 4pcs

83  M10 2pcs

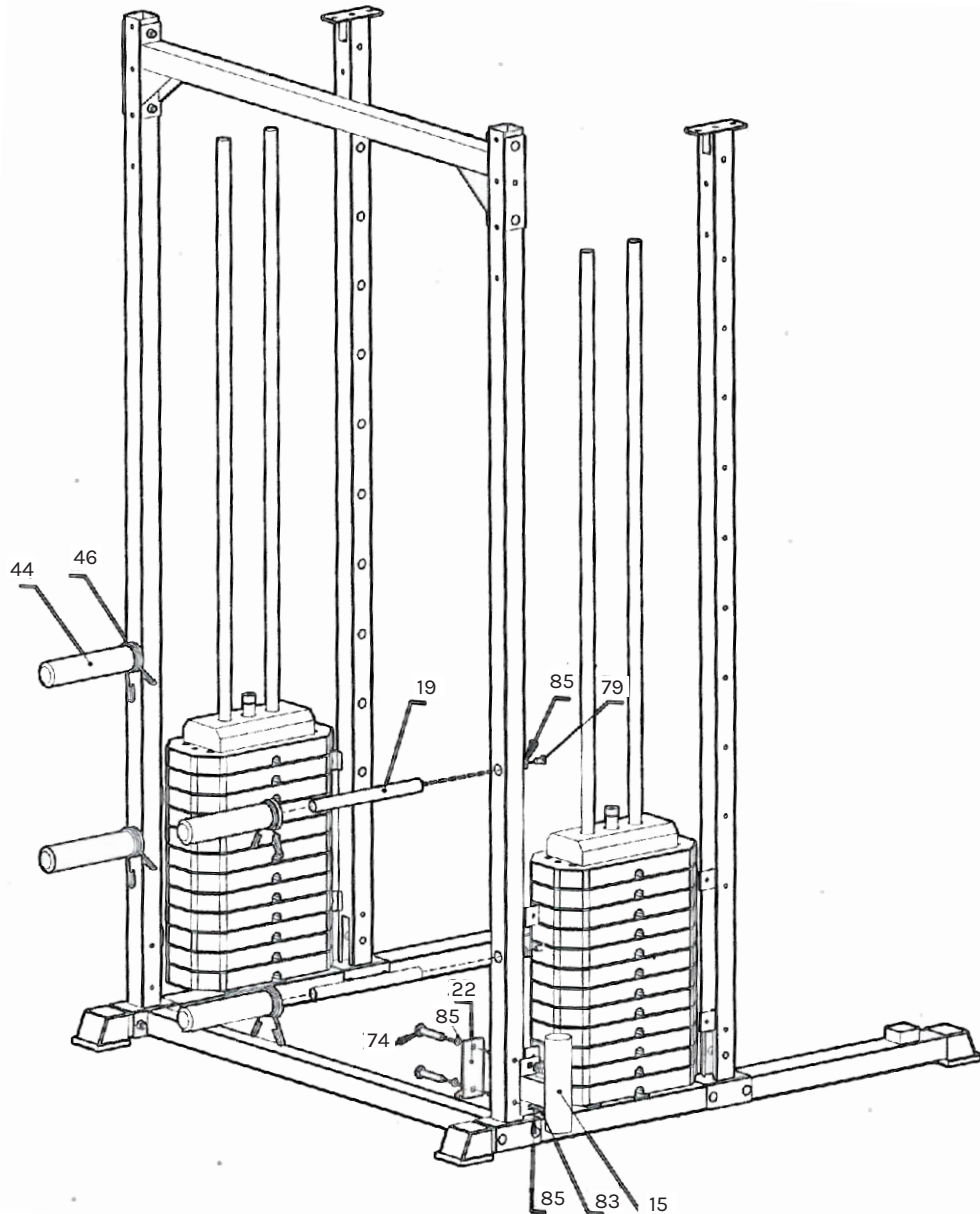

STEP 6

1. Secure 4x part 19 to parts 4 and 5, and

secure with:

- 4x part 79

- 4x part 85

2. Attach part 44 onto part 19 as pictured and

place the collars part 46 into part 44.

3. Secure part 15 onto either post part 4 or 5 using:

- 2x part 74

- 1x part 22

- 2x part 83

- 4x part 85

74  M10 x 70mm 8pcs

82  M8 x 35mm 4pcs

85  $\Phi 10$ 16pcs

83  M10 8pcs

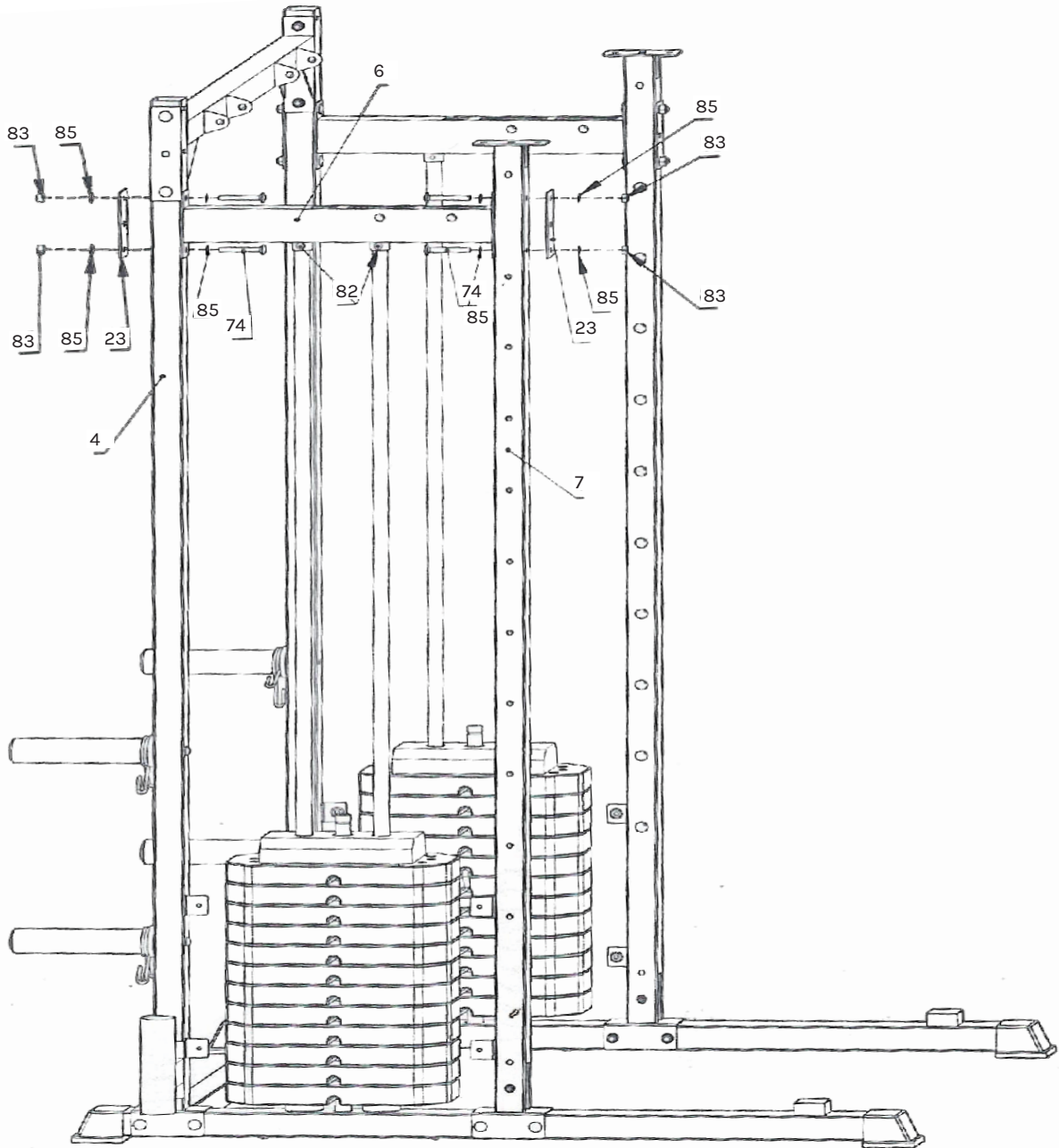

STEP 7

1x Secure part 6 to part 4 and 7 using:

- 2x part 23 - 4x part 74
- 8x part 85 - 4x part 83

2. Secure part 16 onto part 6 with 2x part 82.

3. Repeat steps 1 and 2 on the other side.

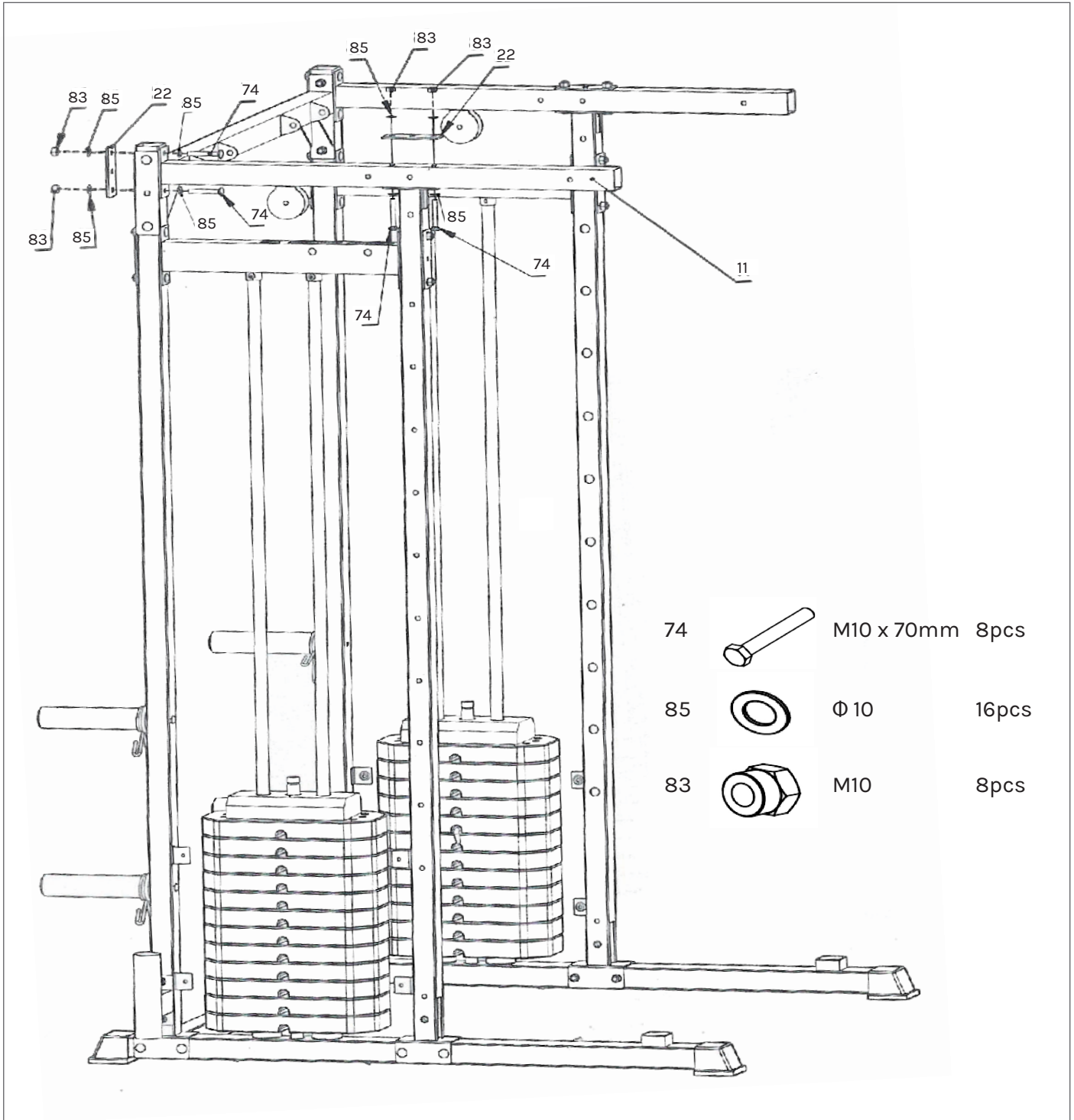

STEP 8



1. Secure part 11 into part 7 using:

- 1x part 22 - 2x part 74
- 4x part 85 - 2x part 83

2. Secure part 11 to part 4 using:

- 1x part 22 - 2x part 74
- 4x part 85 - 2x part 83

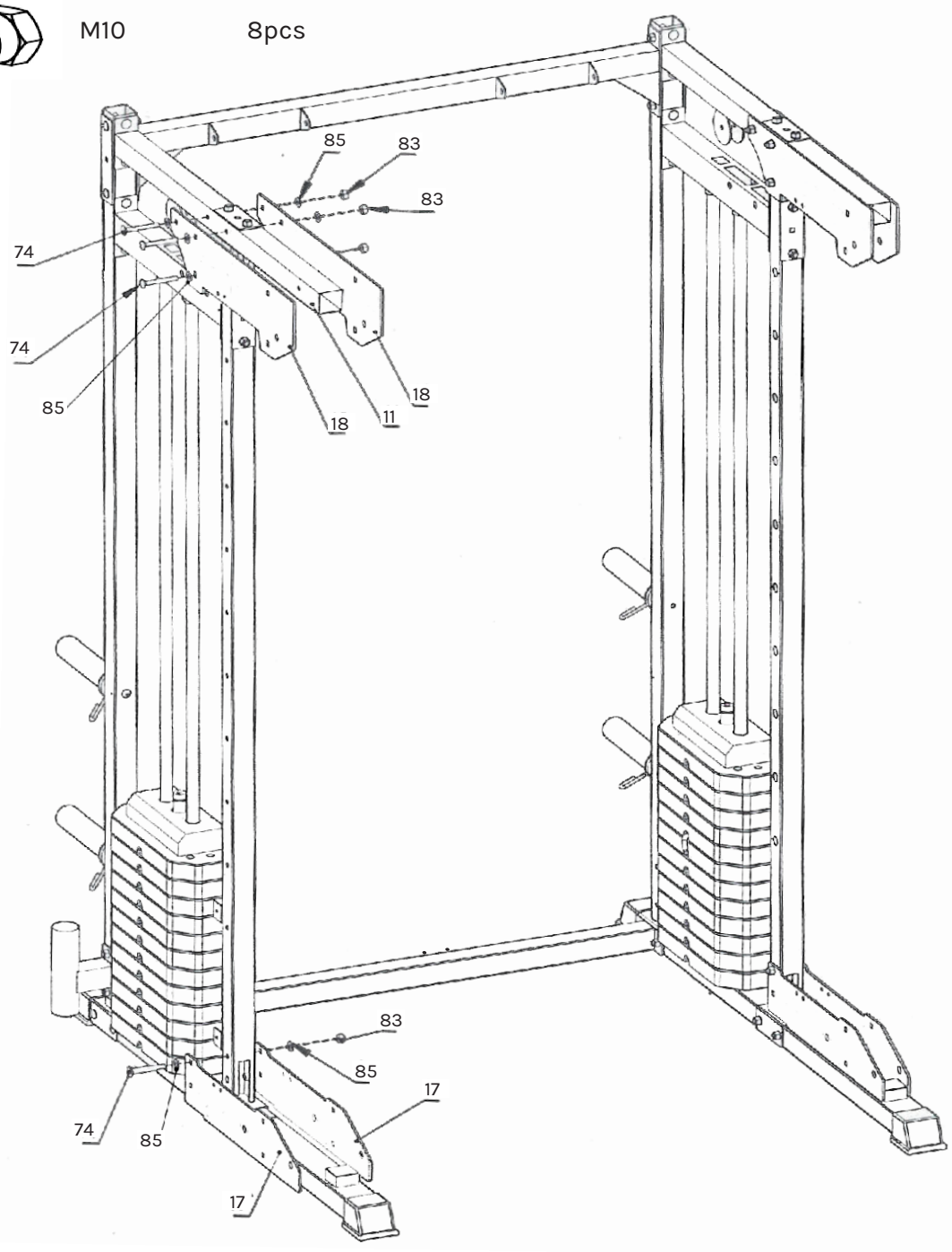

3. Repeat steps 1 and 2 for the other side.

- 74  M10 x 70mm 8pcs
- 85  Ø10 16pcs
- 83  M10 8pcs



STEP 9

1. Secure 2x part 18 onto part 11 using:
 - 3x part 74
 - 6x part 85
 - 3x part 83
2. Repeat step 1 for the other side.
3. Secure 2x part 17 onto part 11 and part 1 using:
 - 1x part 74
 - 2x part 85
 - 1x part 83
4. Repeat step 2 for the other side.

- 74  M10 x 70mm 4pcs
- 85  $\Phi 10$ 8pcs
- 83  M10 4pcs

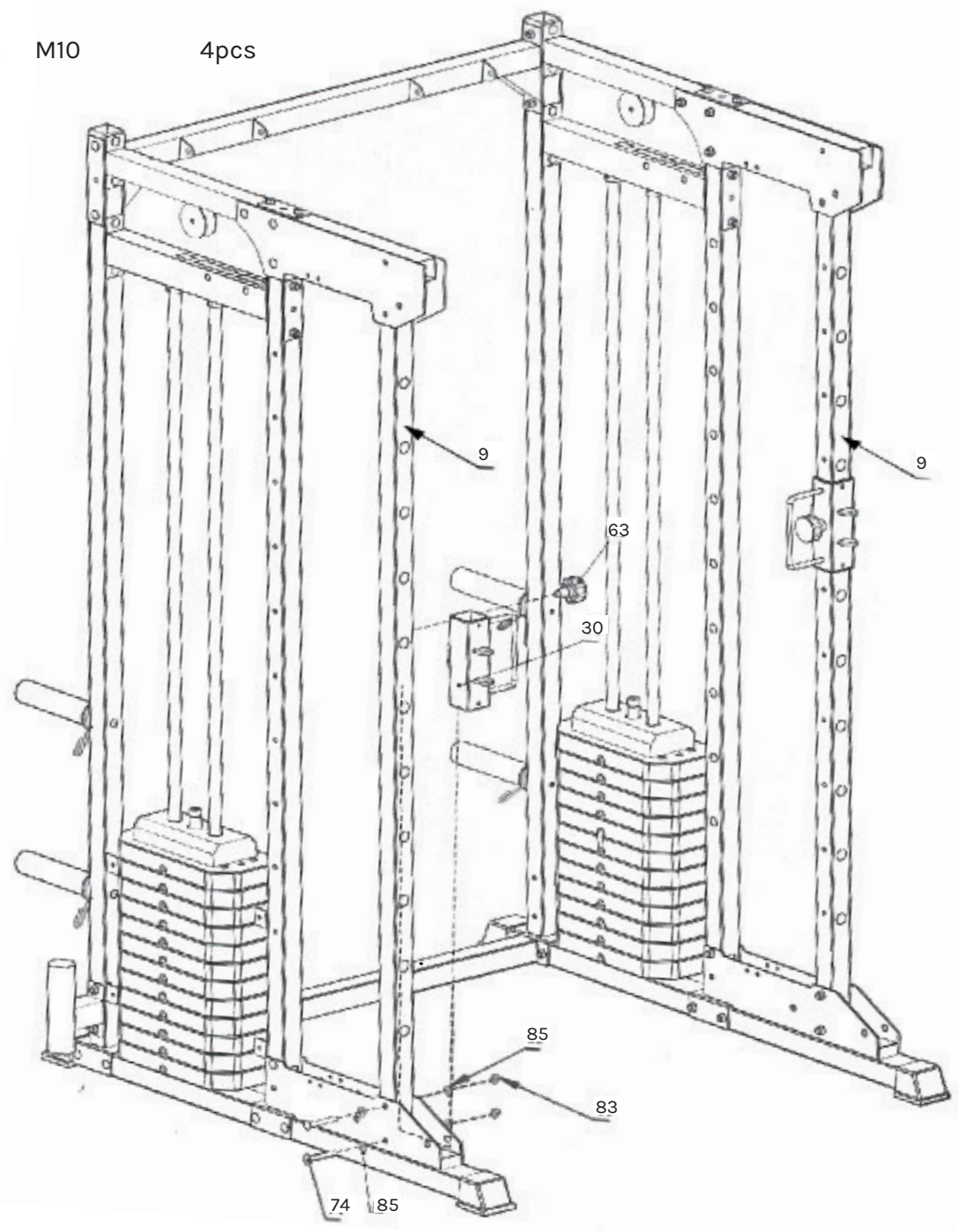



STEP 10

1. Slide part 30 into part 9 post as pictured and secure with part 63.
2. Repeat for the other side.
3. Place part 9 into part 18 and 17 as pictured.

4. Secure part 17 to part 9 using:
 - 2x part 74 - 4x part 85
 - 2x part 83
5. Repeat step 4 on the other side.

73  M10 x 75mm 4pcs

85  $\Phi 10$ 12pcs

79  M10 x 15mm 4pcs

83  M10 4pcs

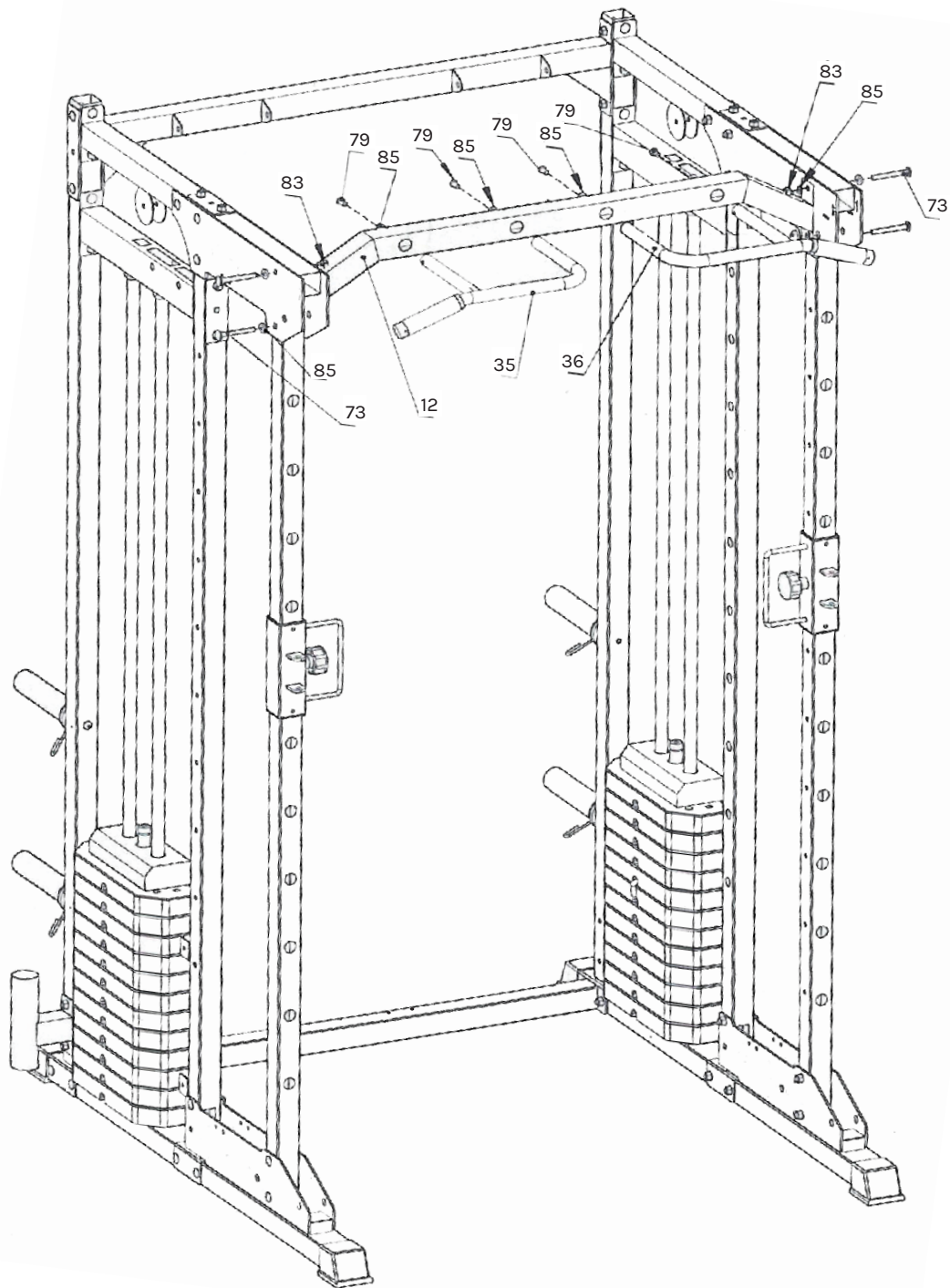





STEP 11

1. Secure part 12 to the top of part 18 using:

- 4x part 73
- 8x part 85
- 4x part 83

2. Secure part 35 and 36 onto part 12 using:

- 4x part 79
- 8x part 85

80		M10 x 110mm	2pcs	85		Φ10	24pcs
79		M10 x 15mm	20pcs	83		M10	2pcs

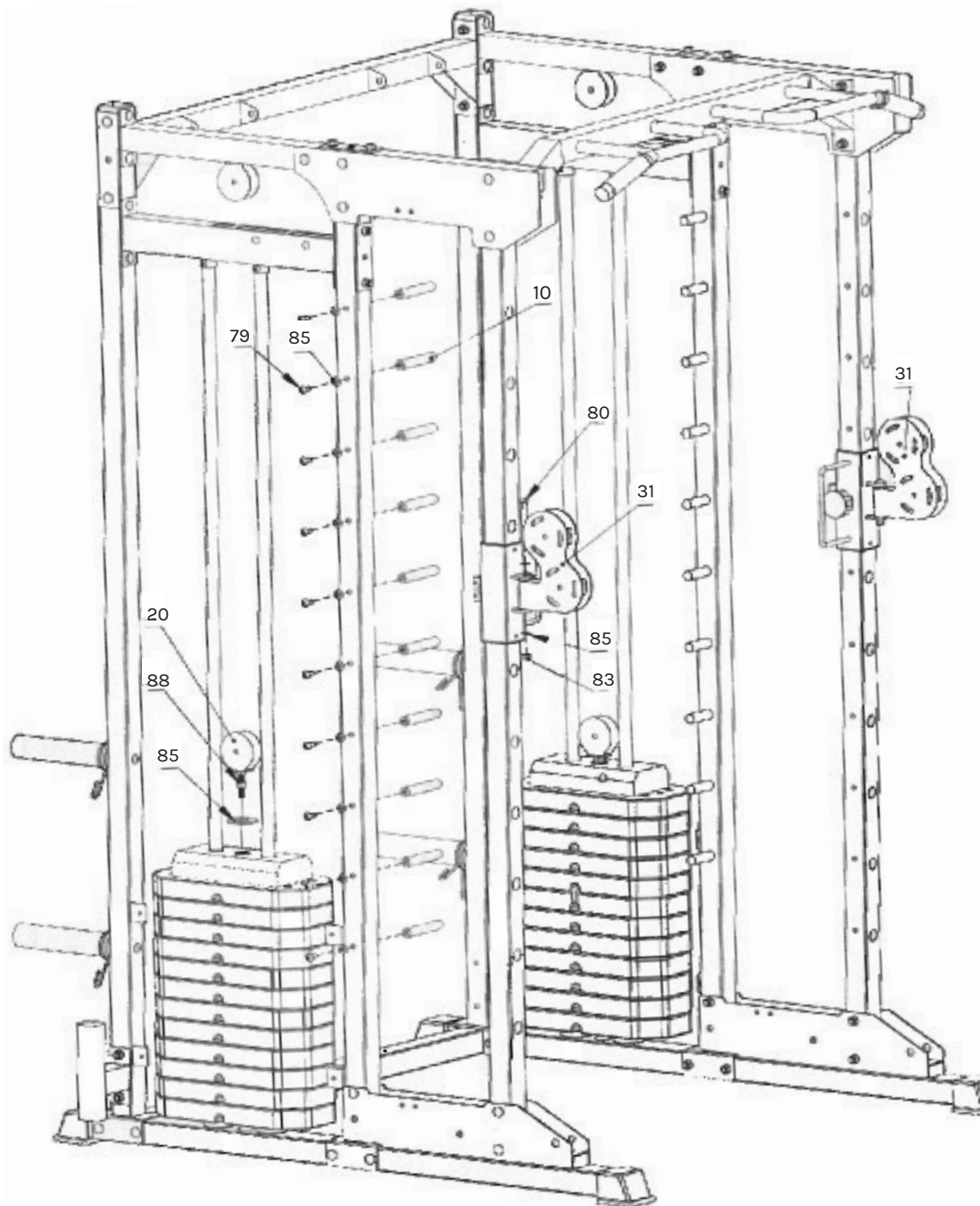

STEP 12

1. Secure part 10 onto part 7 and 8 using:

- 20x part 79 (pre-installed on part 10)
- 20x part 85

2. Attach part 20 to part 88, then connect part 88 with part 85 onto part 21, in order as shown.

3. Repeat step 2 for the other side.

4. Fit the sleeve into part 31. Then secure part 31 to part 30 using:

- 2x part 80
- 2x part 83
- 4x part 85

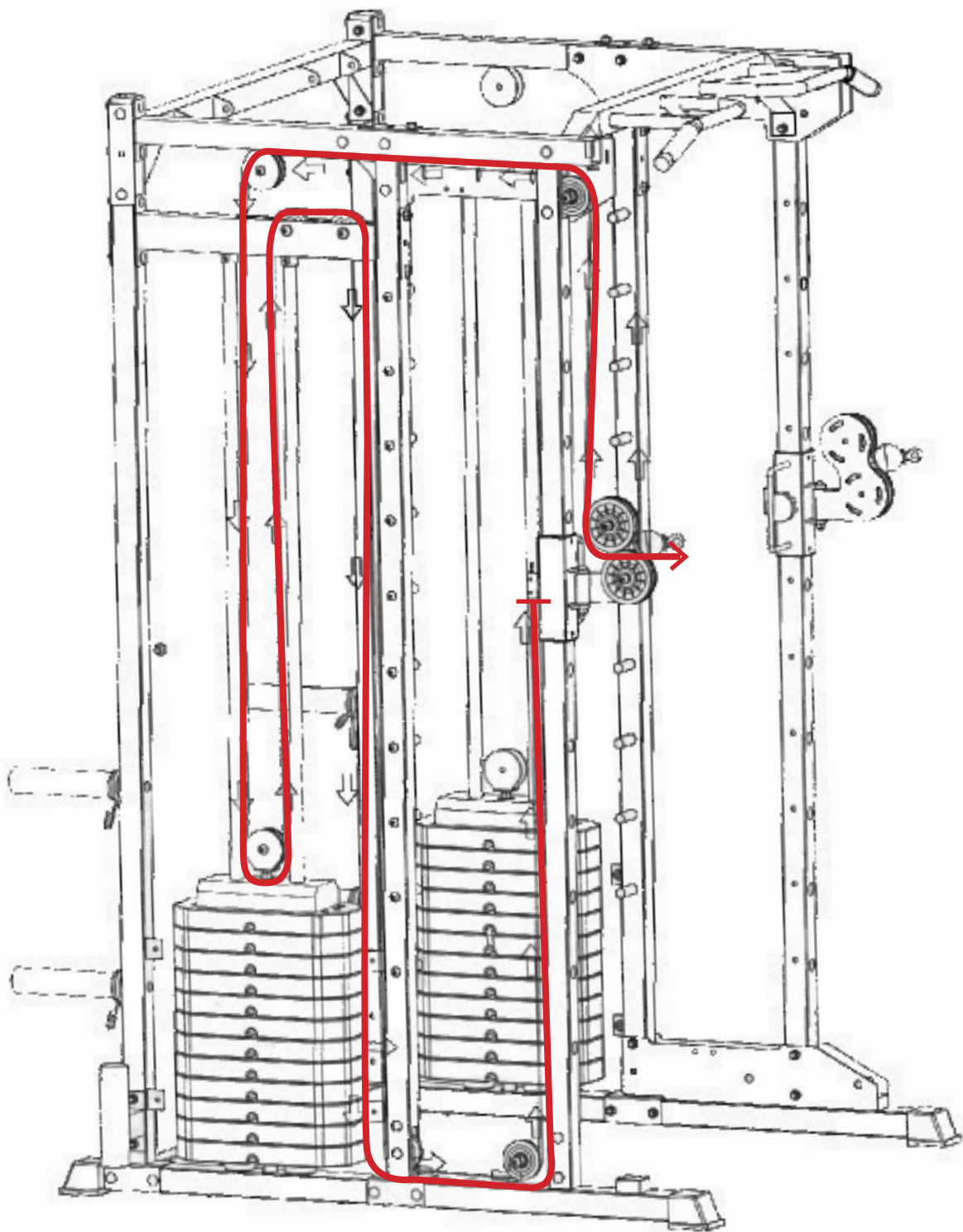

STEP 13

NOTE: Be sure to install the wire rope before installing the pulley. See next page for pulley assembly instructions.

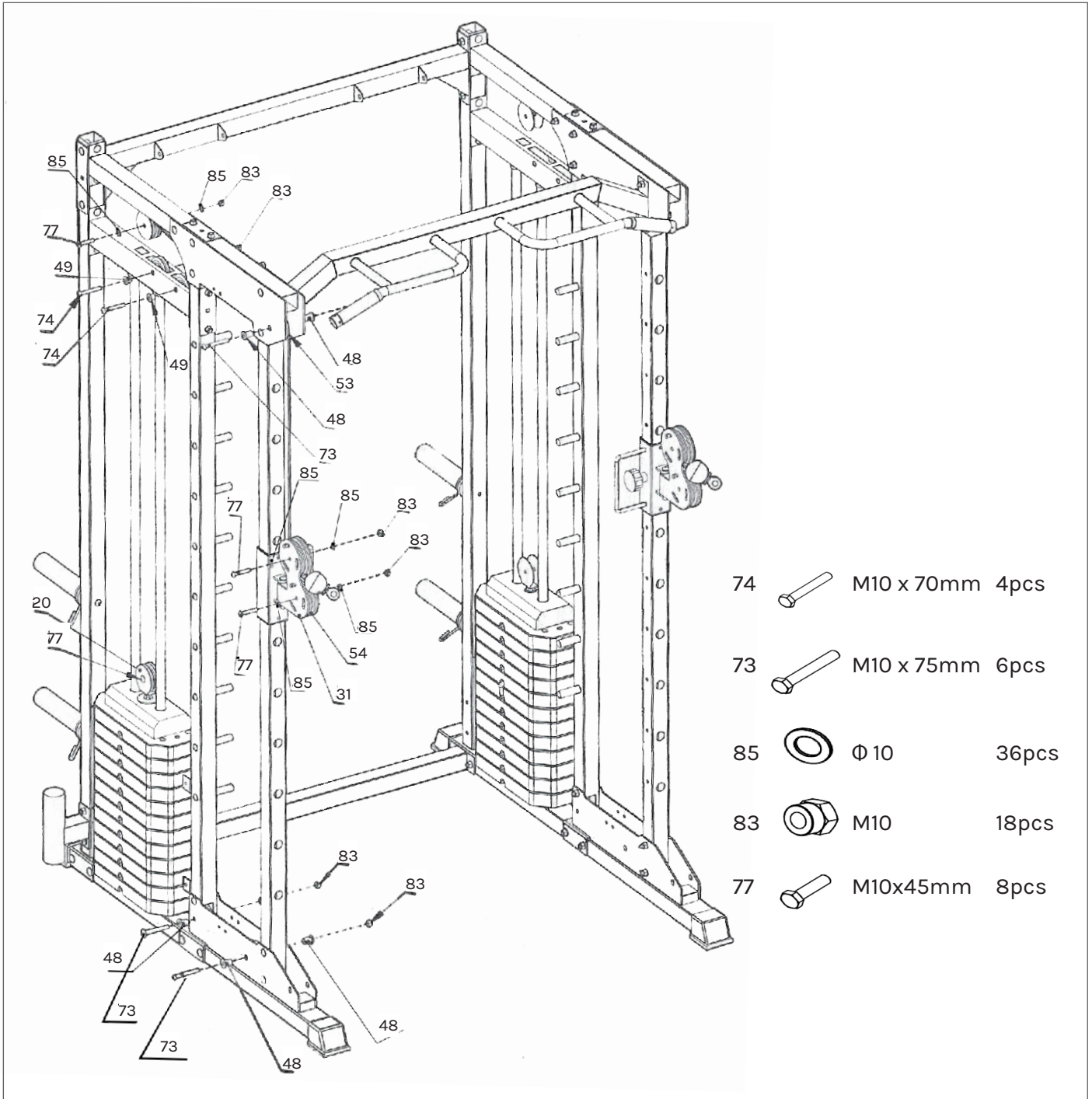

STEP 13

1. Secure the part 52 on part 11 using:

- 1x part 77 - 1x part 83 - 2x part 85

2. Repeat step 1 on other side.

3. Secure 2x part 52 to part 6 using:

- 2x part 74 - 2x part 49
- 2x part 83 - 4x part 85

4. Repeat step 3 for the other side.

5. Secure 4x part 52 into part 31 using:

- 4x part 77 - 8x part 85 - 4x part 83

6. Secure 4x part 52 into part 17 using:

- 4x part 73 - 4x part 48
- 4x part 83 - 8x part 85

7. Secure 2x part 52 into part 22 using:

- 2x part 77

79  M10 x 15mm 3pcs

86  $\Phi 8$ 16pcs

85  $\Phi 10$ 5pcs

71  M10 x 90mm 1pc

78  M8x16mm 8pcs

83  M10 1pc

84  M8 8pcs

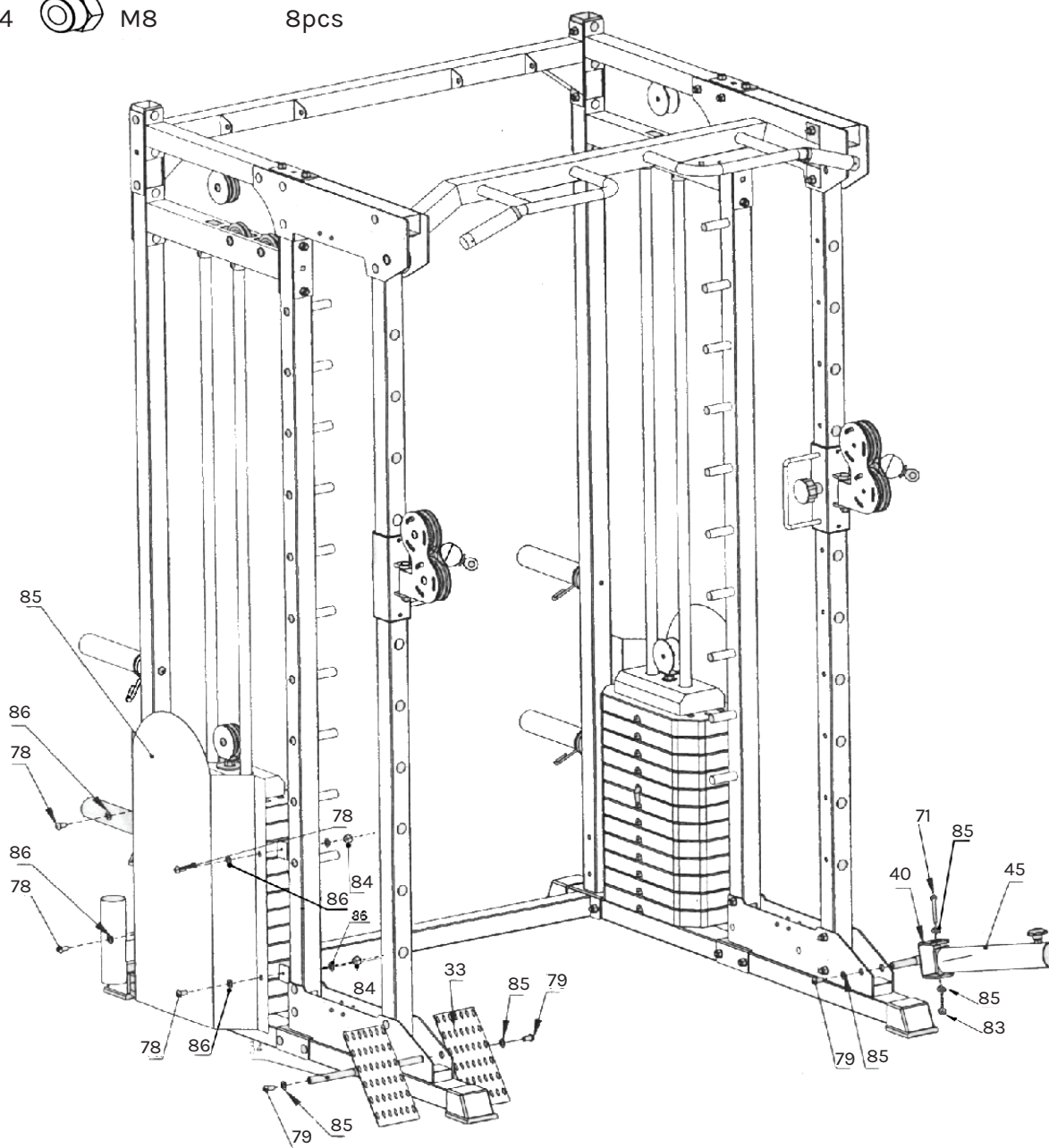

STEP 14

1. Secure weight covers 2x part 25 using:

- 8x part 78 - 8x part 86

2. Secure row foot plate part 33 using:

- 2x part 79 - 2x part 85

3. Secure landmine post part 45 to part 40 using:

- 1x part 71 - 2x part 85 - 1x part 83

4. Secure part 40 to part 17 using:

- 1x part 79 - 1x part 85

79  M10 x 15mm 2pcs

85  $\Phi 10$ 2pcs

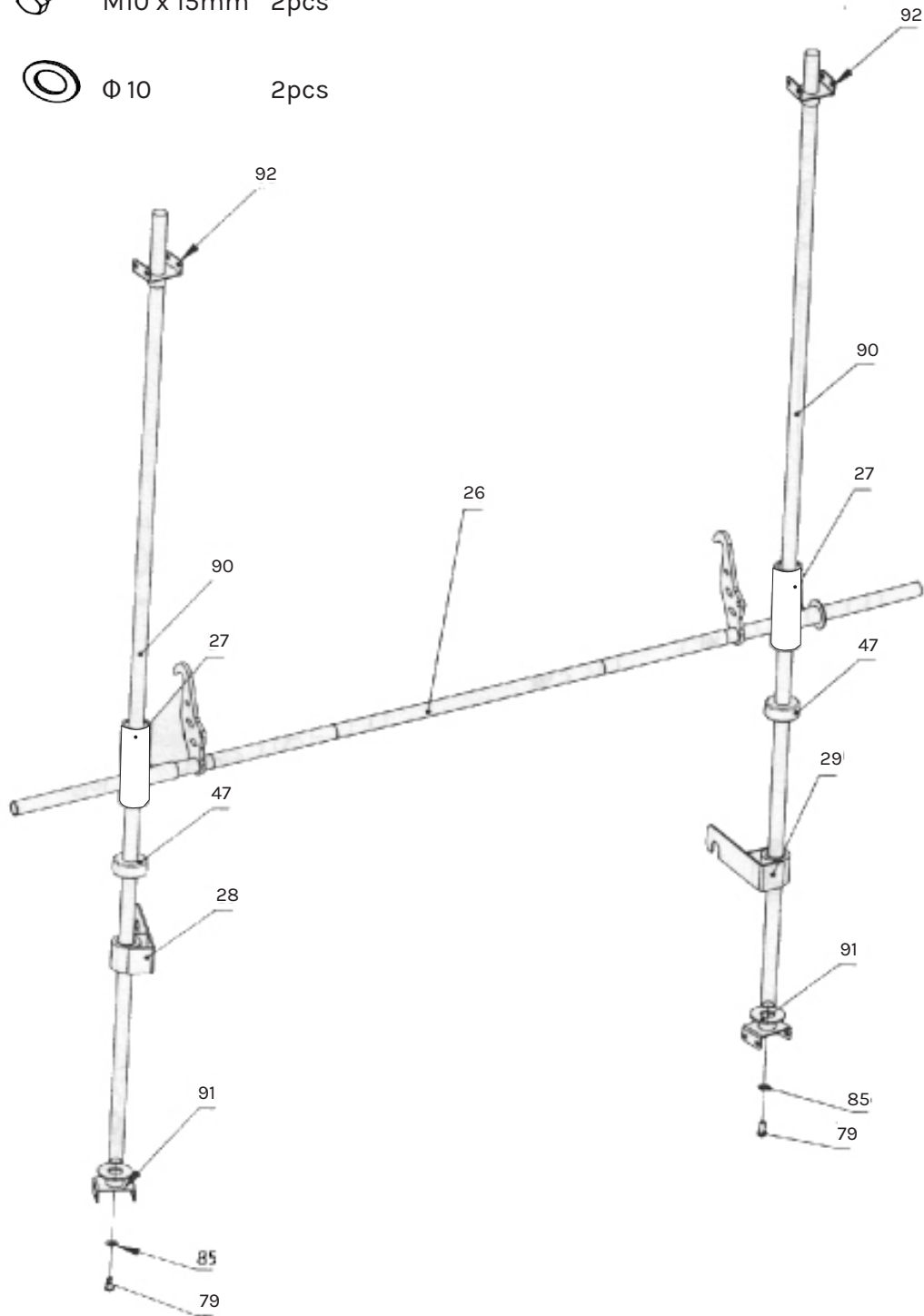

STEP 15

1. Place part 26 tube into 2x part 27.
2. Place the 2x part 27 onto the 2x part 90 as pictured.
3. Place 2x part 92 as pictured on part 90.
4. Place 2x part 47 onto part 90.
5. Place 2x part 28 onto part 90.
6. Place 2x part 91 onto 2x part 90 and secure using:
- 2x part 85 - 2x part 79

81  M8 x 80mm 8pcs

86  $\Phi 8$ 16pcs

84  M8 8pcs

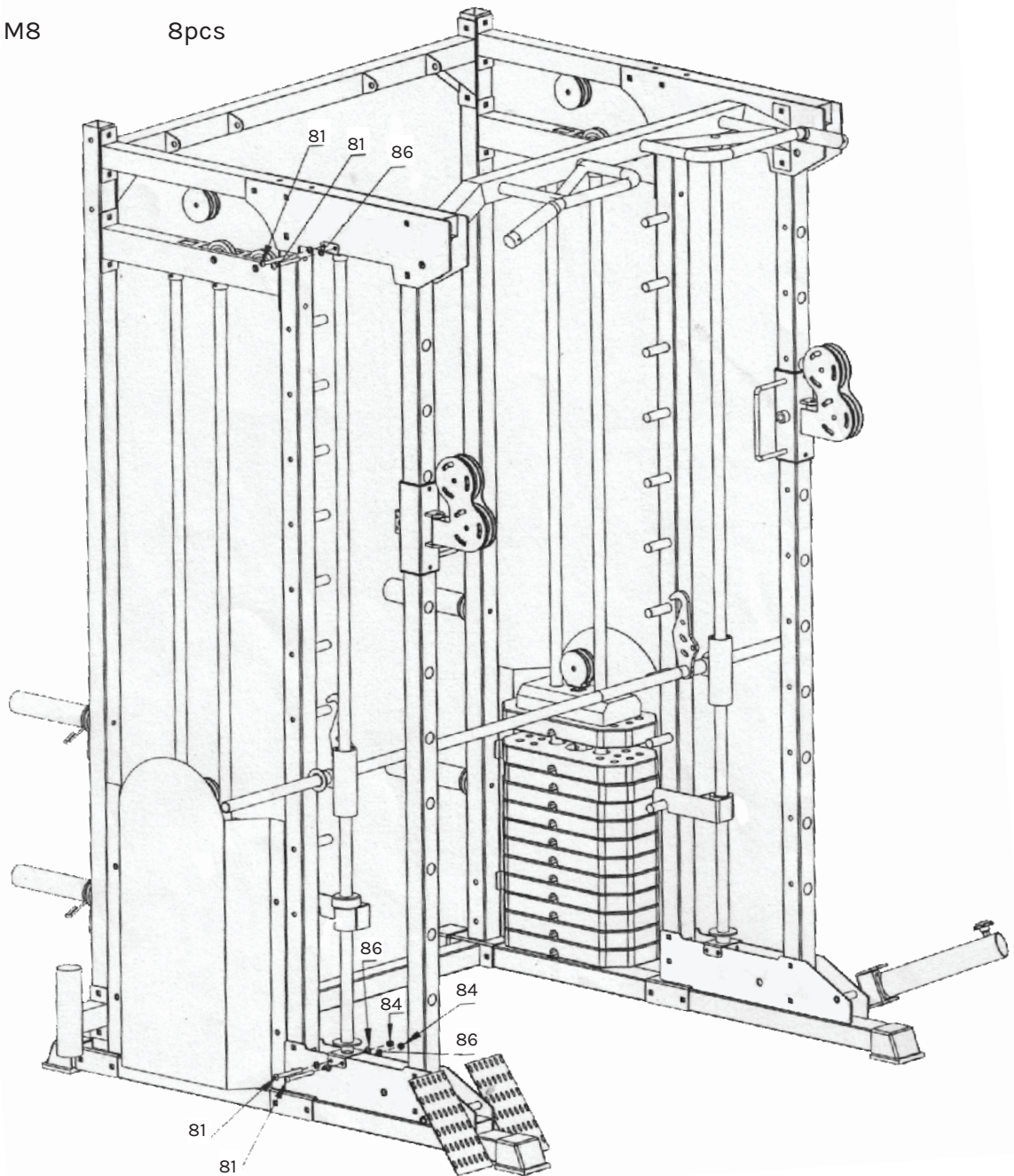

STEP 16

1. Secure the Smith bar you just assembled onto the rack part 17 and 18 using:

- 8x part 81
- 16x part 86
- 8x part 84

Ensure to fully tighten all screws.

OPTIONAL ATTACHMENT

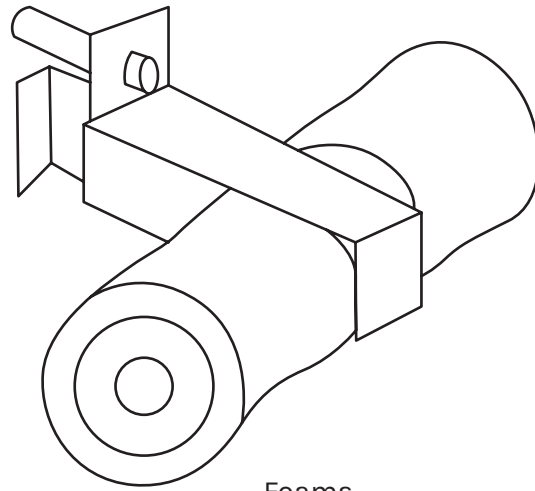

Foams

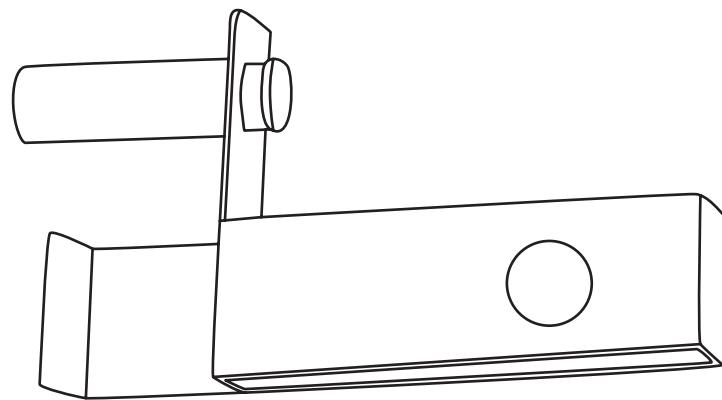

Foam Attachment Bracket

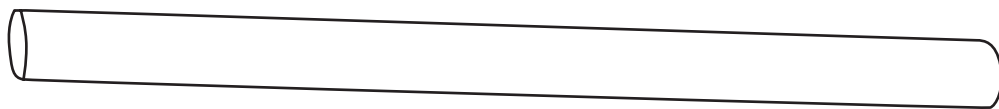

Foam Rod

Foam Roller Attachment Assembly

1. Attach the Foam rods onto slot for the Foam roller attachment bracket.
2. Place the foams onto each end of the Rod.
3. Slot the attachment into the holes for the rack when using for lat pull down bar.



Landmine Barbell
Bracket



Nut

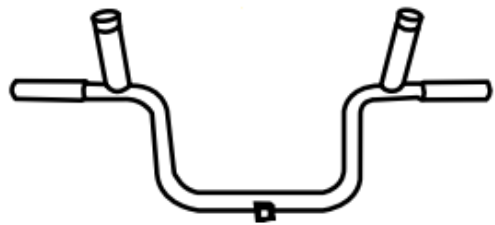

Landmine Handle

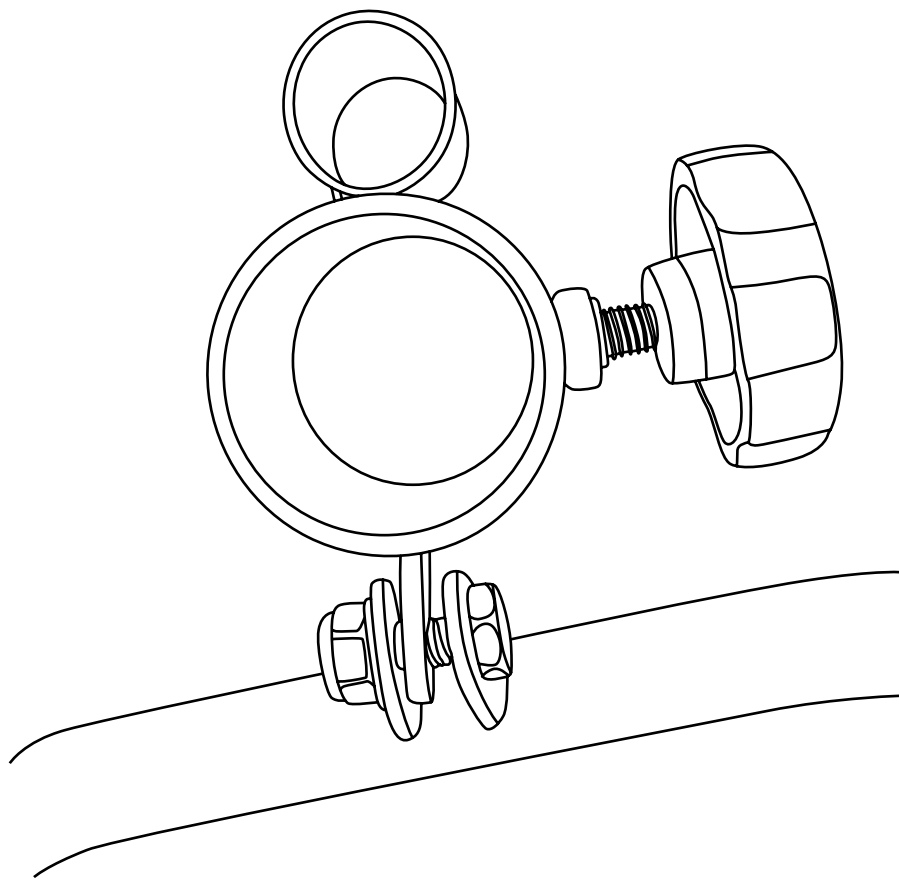

Landmine Handlebar Assembly

1. Bolt the landmine barbell bracket to the landmine handles (with screws from the landmine handle).
2. When using with separate barbell. Insert barbell into the barbell bracket and tighten with the nut.

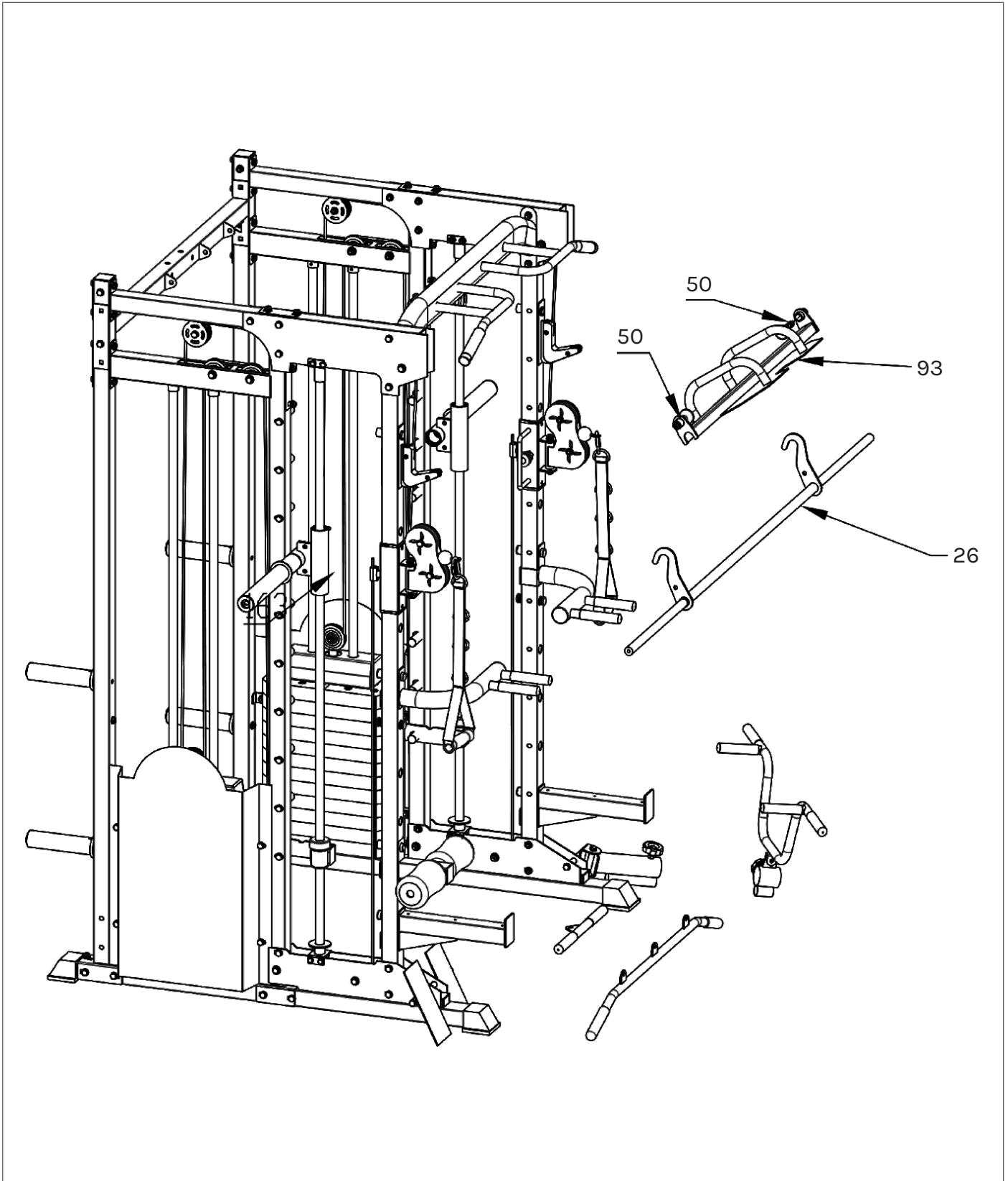

Leg Press Attachment Assembly

1. Install (# 93) at the position shown in (# 26) smith bar and secure it with (# 50) Spring pull pin.

V. EXERCISE GUIDE

! PLEASE NOTE:

Before beginning any exercise program, consult your physician. This is important especially if you are over the age of 45 or individuals with pre-existing health problems.

The pulse sensors are not medical devices. Various factors, including the user's movement, may affect the accuracy of heart rate readings. The pulse sensors are intended only as an exercise aid in determining heart rate trends in general.

Exercising is a great way to control your weight, improve your fitness and reduce the effect of aging and stress. The key to success is to make exercise a regular and enjoyable part of your everyday life.

The condition of your heart and lungs and how efficient they are in delivering oxygen via your blood to your muscles is an important factor to your fitness. Your muscles use this oxygen to provide enough energy for daily activity. This is called aerobic activity. When you are fit, your heart will not have to work so hard. It will pump a lot fewer times per minute, reducing the wear and tear of your heart.

So as you can see, the fitter you are, the healthier and greater you will feel.

WARM UP

Start each workout with 5 to 10 minutes of stretching and some light exercises. A proper warm-up increases your body temperature, heart rate and circulation in preparation for exercise. Ease into your exercise.

After warming up, increase the intensity to your desired exercise program. Be sure to maintain your intensity for maximum performance. Breathe regularly and deeply as you exercise.

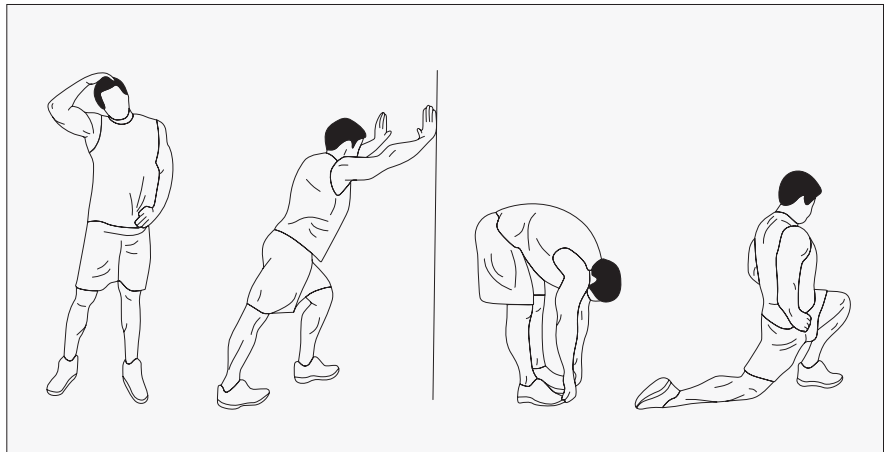

COOL DOWN

Finish each workout with a light jog or walk for at least 1 minute. Then complete 5 to 10 minutes of stretching to cool down. This will increase the flexibility of your muscles and will help prevent post-exercise problems.

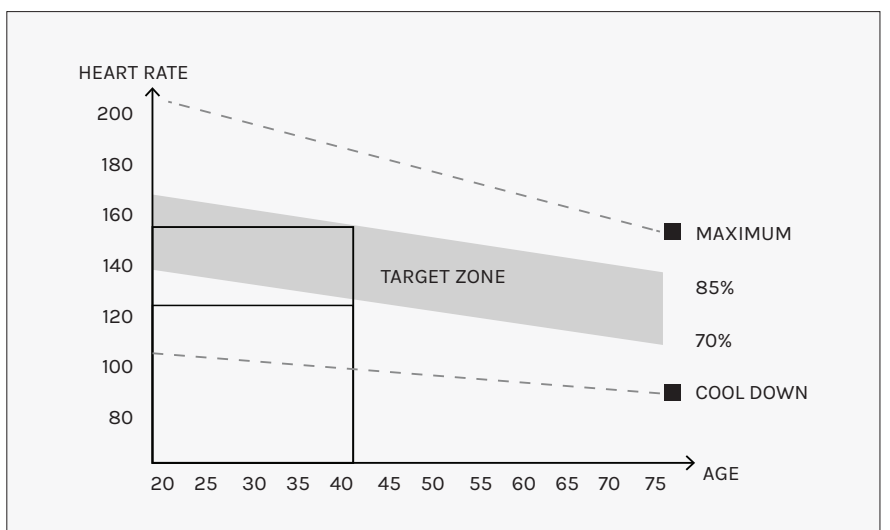

WORKOUT GUIDELINES

! This is how your pulse should behave during general fitness exercise. Remember to warm up and cool down for a few minutes.

VI. MAINTENANCE

MAINTENANCE METHOD:

To extend the service life of the device, the parts must be lubricated on time. The product has been initially lubricated before leaving the factory, but lubrication is required between the guide rod and the weight plate over time.

 **NOTE:** Silicon oil/spray is recommended for lubrication.

1. Pulley and wire ropes should be regularly checked for signs of wear.
2. Check and adjust the tension of the wire rope regularly.
3. Check all moving parts regularly. If there is a damaged part, stop using the device immediately and contact the store.
4. Ensure all bolts and nuts are fully fixed and re-tighten them when it is loose.
5. Check the welding for cracks.
6. Failure to perform routine maintenance may cause personal injury or equipment damage.
7. Ensure any handle attachments are fully secured before use to prevent from injury.

VII. WARRANTY

AUSTRALIAN CONSUMER LAW

Many of our products come with a guarantee or warranty from the manufacturer. In addition, they come with guarantees that cannot be excluded under the Australian Consumer Law. You are entitled to a replacement or refund for a major failure and compensation for any other reasonably foreseeable loss or damage.

You are entitled to have the goods repaired or replaced if the goods fail to be of acceptable quality and the failure does not amount to a major failure. Full details of your consumer rights may be found at www.consumerlaw.gov.au.

Please visit our website to view our full warranty terms and conditions:
<http://www.lifespanfitness.com.au/warranty-repairs>

WARRANTY AND SUPPORT

Any claim against this warranty must be made through your original place of purchase. Proof of purchase is required before a warranty claim may be processed.

If you have purchased this product from the Official Lifespan Fitness website, please visit <https://lifespanfitness.com.au/warranty-form>

For support outside of warranty, if you wish to purchase replacement parts or request a repair or service, please visit <https://lifespanfitness.com.au/warranty-form> and fill in our Repair/Service Request Form or Parts Purchase Form.

Scan this QR code with your device to go to lifespanfitness.com.au/warranty-form



CORTEX[®]

WWW.LIFESPANFITNESS.COM.AU