

LSG

GLP100 Seated Leg Press & Hack Squat Machine

USER MANUAL



Find the
Digital Manual
Online

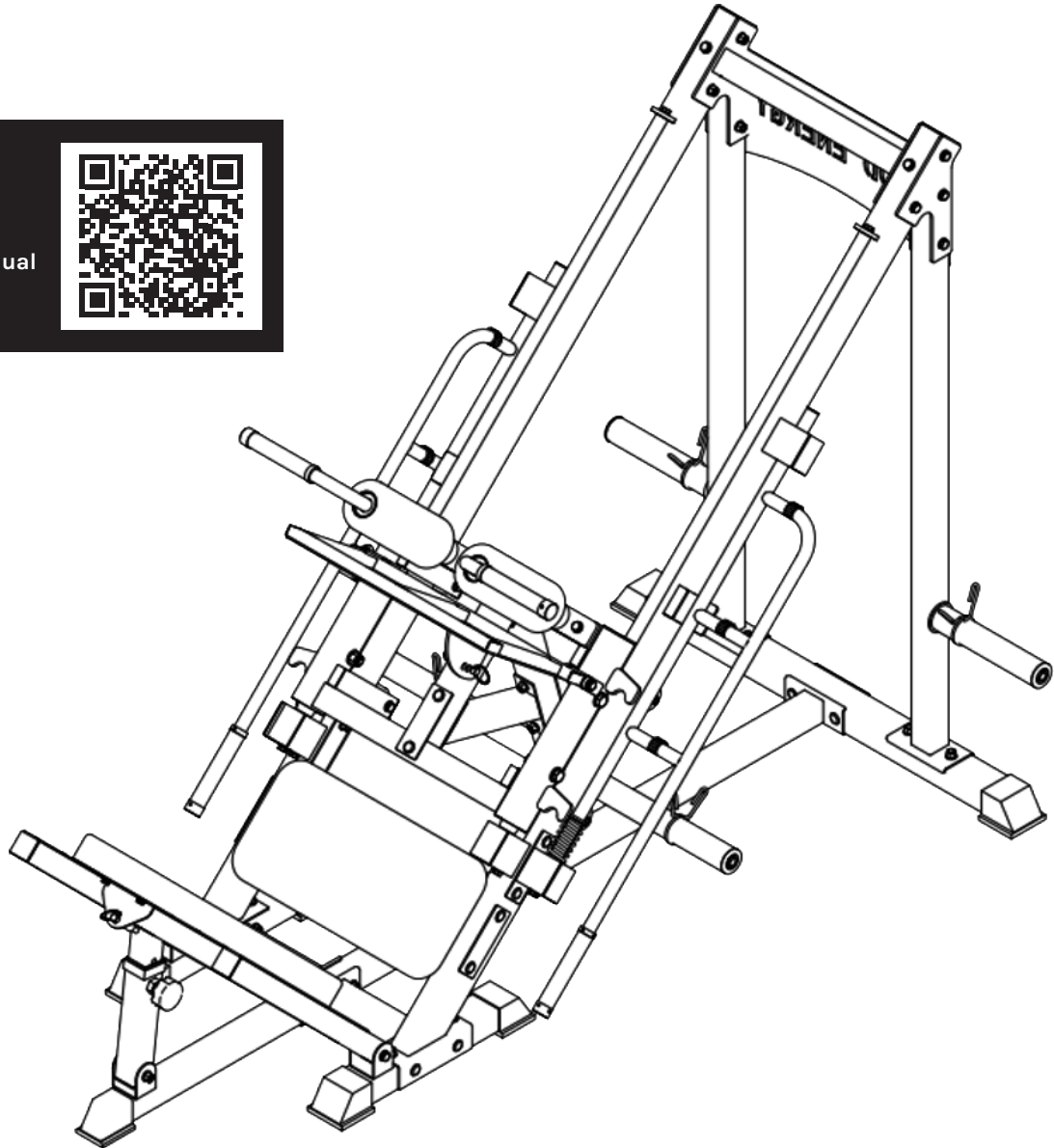

Product may vary slightly from the item pictured due to model upgrades.



**Read all instructions carefully before using this product.
Retain this owner's manual for future reference.**

NOTE:

This manual may be subject to updates or changes. Up to date manuals are available through our website at www.lsgfitness.com.au



TABLE OF CONTENTS

I. Important Safety Instructions	03
II. Parts List	04
III. Assembly Instructions	07
IV. Warranty	13

I. IMPORTANT SAFETY INSTRUCTIONS

To ensure your safety, please read the following precautions before using this product.

SAFETY PRECAUTIONS:

1. Carefully read and understand all instructions and warning labels before use. Familiarize yourself with the proper operation of the device by reviewing this manual or consulting with your local retailer.
2. Keep this manual accessible and ensure all warning labels remain clear and legible.
3. This product is recommended to be assembled by two or more people.
4. Consult a doctor before beginning any exercise routine.
5. Ensure the safety of children when they are present around the device.
6. Exercise caution when using the device in the presence of children.
7. Regularly check for signs of wear and tear, as these can pose safety risks.
8. Keep hands, limbs, and clothing free to ensure safe and effective use of the device.
9. Inspect for any signs of mechanical wear, loose hardware, or cracks in the welding. If any are detected, stop using the device immediately and contact our after-sales service team.
10. Use a wrench or Allen wrench to complete assembly as required.

MAINTENANCE AND UPKEEP:

To extend the lifespan of this equipment, timely lubrication of its components is essential. While the equipment is pre-lubricated before leaving the factory, after a certain period, it will require additional lubrication of the guide rods. Contact our after-sales service department for further assistance.

! IMPORTANT:

Do not use engine oil or grease, as these attract dust and dirt. Silicon oil/spray is recommended for lubrication.

1. Regularly inspect all parts for signs of wear.
2. Check all moving parts and handles for wear or damage.
3. Ensure that all bolts and nuts are securely tightened. If any are loose, tighten them immediately.
4. Inspect welds for cracks; discontinue use if any are found.
5. Failure to perform routine maintenance may lead to personal injury or equipment damage.

II. PARTS LIST

1

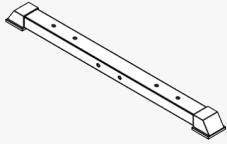

1pc.

2

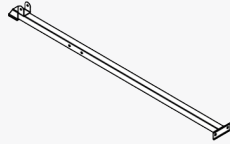

1pc.

3

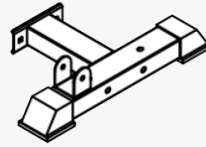

1pc.

4

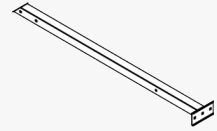

1pc.

5

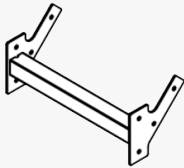

1pc.

6

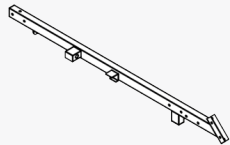

1pc.

7

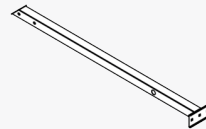

1pc.

8

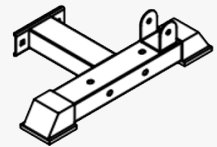

1pc.

9

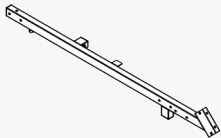

1pc.

10

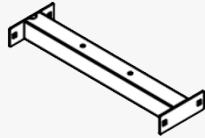

1pc.

11

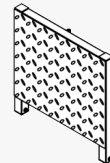

1pc.

12



1pc.

13

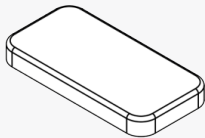

1pc.

14

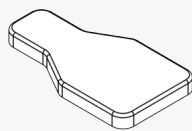

1pc.

15

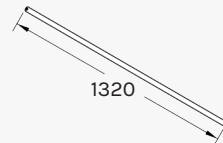

1320

2pcs.

16

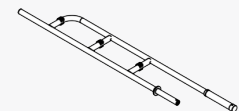

2pcs.

17

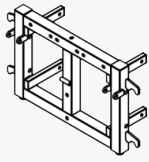

1pc.

18

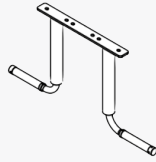

1pc.

19



1pc.

20

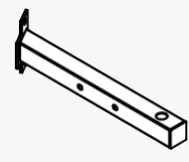

1pc.

21

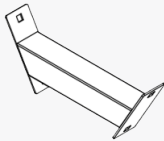

1pc.

22

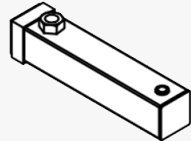

1pc.

23

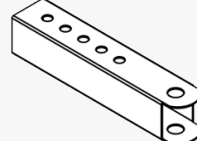

1pc.

24

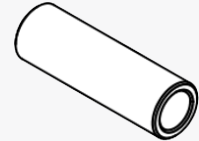

(φ11 x φ16 x 50)
1pc.

25



2pcs.

26

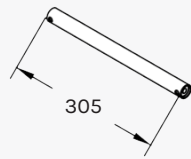

2pcs.

27

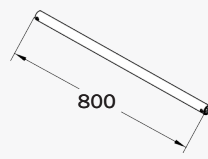

1pc.

28

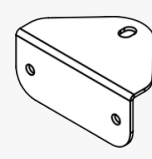

1pc.

29

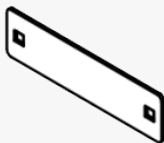

50 x 170 x 3mm
2pcs.

30

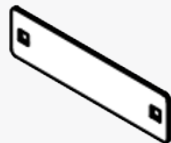

50 x 140 x 3mm
11pcs.

31

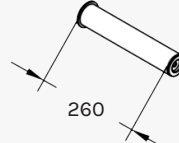

2pcs.

32

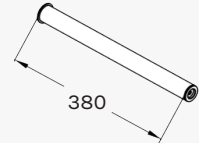

2pcs.

33

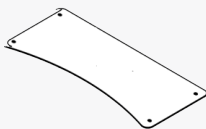

1pc.

34



2pcs.

35

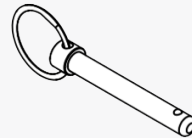

10 x 70mm
2pcs.

36

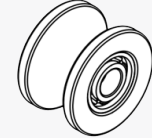

4pcs.

37

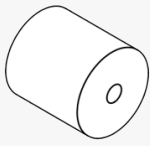

4pcs.

38

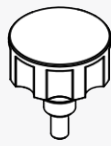

M10
1pc.

39



4pcs.

40A

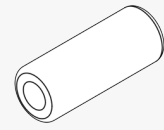

$\phi 50 \times \phi 100 \times 250$
1pc.

40

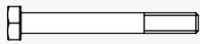

M10 x 80
5pcs.

41



M10 x 75
13pcs.

42



M10 x 85
2pcs.

43



M10 x 90
4pcs.

44

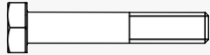

M14 x 75
4pcs.

45



M8 x 65
2pcs.

46



M8 x 20
2pcs.

47

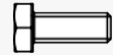

M10 x 20
8pcs.

48



M10 x 45
4pcs.

49



M10 x 70
22pcs.

50



M10 x 75
2pcs.

51



M10 x 90
6pcs.

52

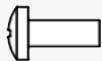

M6 x 16
6pcs.

53



$\phi 6$
4pcs.

54



$\phi 10$
98pcs.

55



$\phi 14$
8pcs.

56



$\phi 8$
4pcs.

57

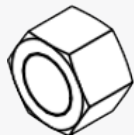

M10
52pcs.

58

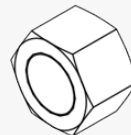





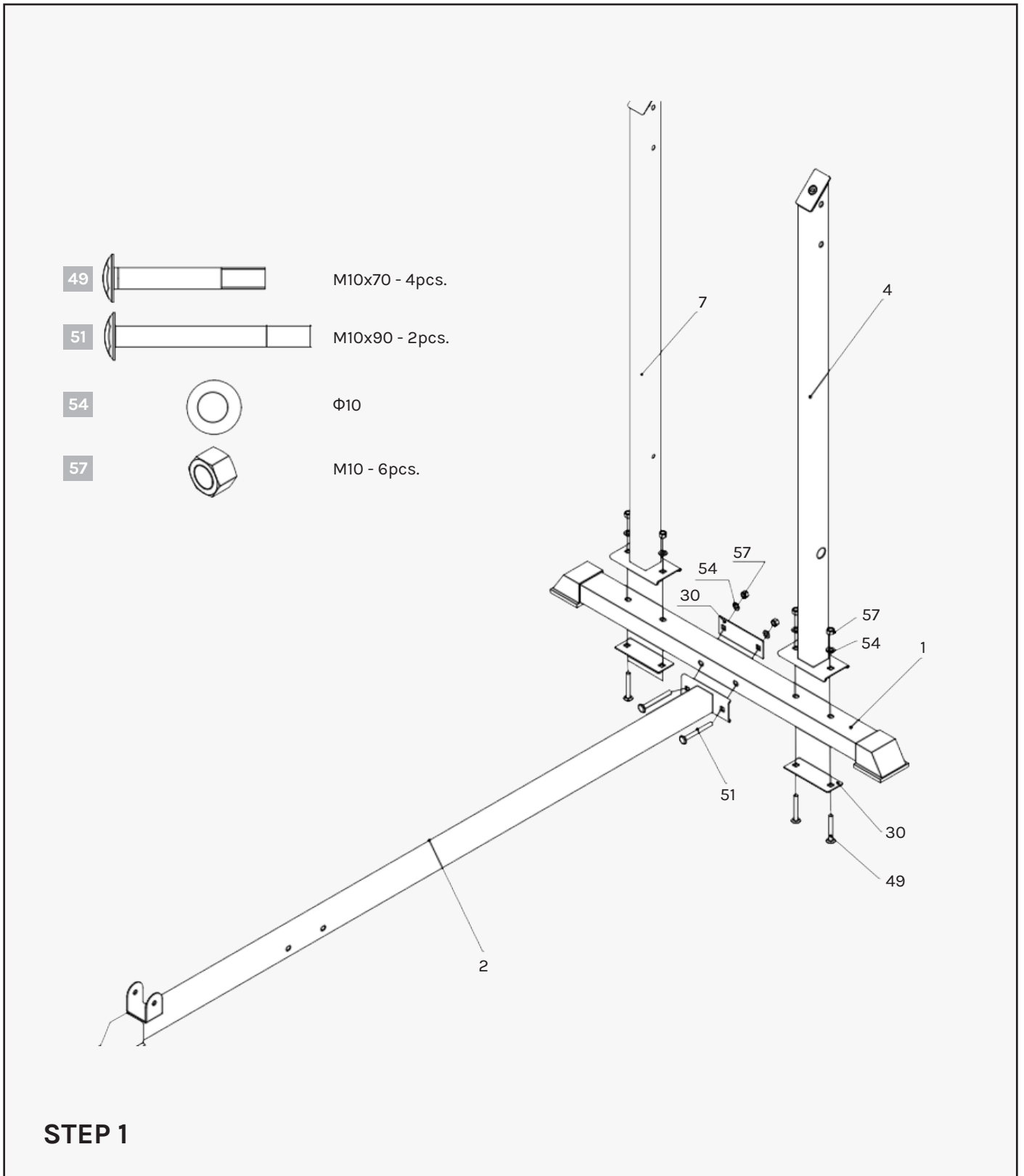

M14
4pcs.

III. ASSEMBLY INSTRUCTIONS







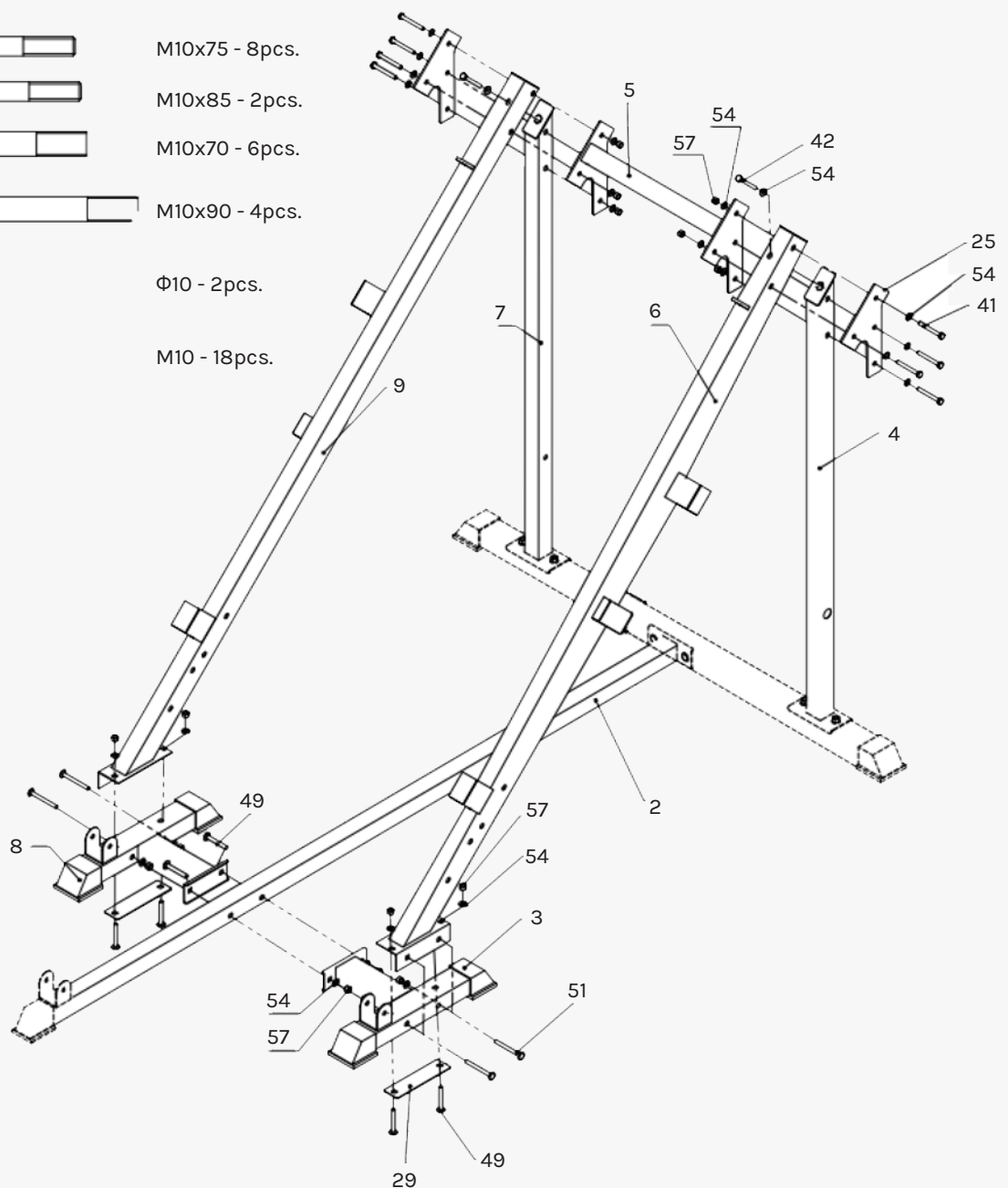

1. Connect and fix parts 4#, 30# plate, and 1# with two pieces each of 49# bolts, 54# washers, and 57# nuts. Do not fully tighten the connections yet. Repeat for the other side for part #7.
2. Connect and fix parts 2#, 30# plate, and 1# with two pieces each of 51# bolts, 54# washers, and 57# nuts. These connections should also remain temporarily loose.

41		M10x75 - 8pcs.
42		M10x85 - 2pcs.
49		M10x70 - 6pcs.
51		M10x90 - 4pcs.
54		Φ10 - 2pcs.
57		M10 - 18pcs.

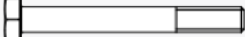

STEP 2

1. Connect and fix parts 3# and part 6#, as well as parts 8# and part 9#, with two pieces each of 51# bolts, 54# washers, and 57# nuts. Do not fully tighten these connections yet.
2. Connect and fix part 4# to part 6# and part 7# to part 9# with one piece each of 42# bolt and 54# washer. Additionally, connect parts 3#, 6#, and 29# plate with two pieces each of 49# bolts, 54# washers, and 57# nut. Connect parts 9# and 8# in the same manner. Keep all connections temporarily loose.
3. Connect part 5# and two pieces of 25# plate between parts 4# and 7# using four pieces of 41# bolts, eight pieces of 54# washers, and eight pieces of 57# nuts.

- 40  M10x80 - 3pcs.
- 41  M10x75 - 1pc.
- 47  M10x20 - 2pcs.
- 48  M10x45 - 2pcs.
- 49  M10x70 - 4pcs.
- 54  $\Phi 10$ - 16pcs.
- 57  M10 - 8pcs.

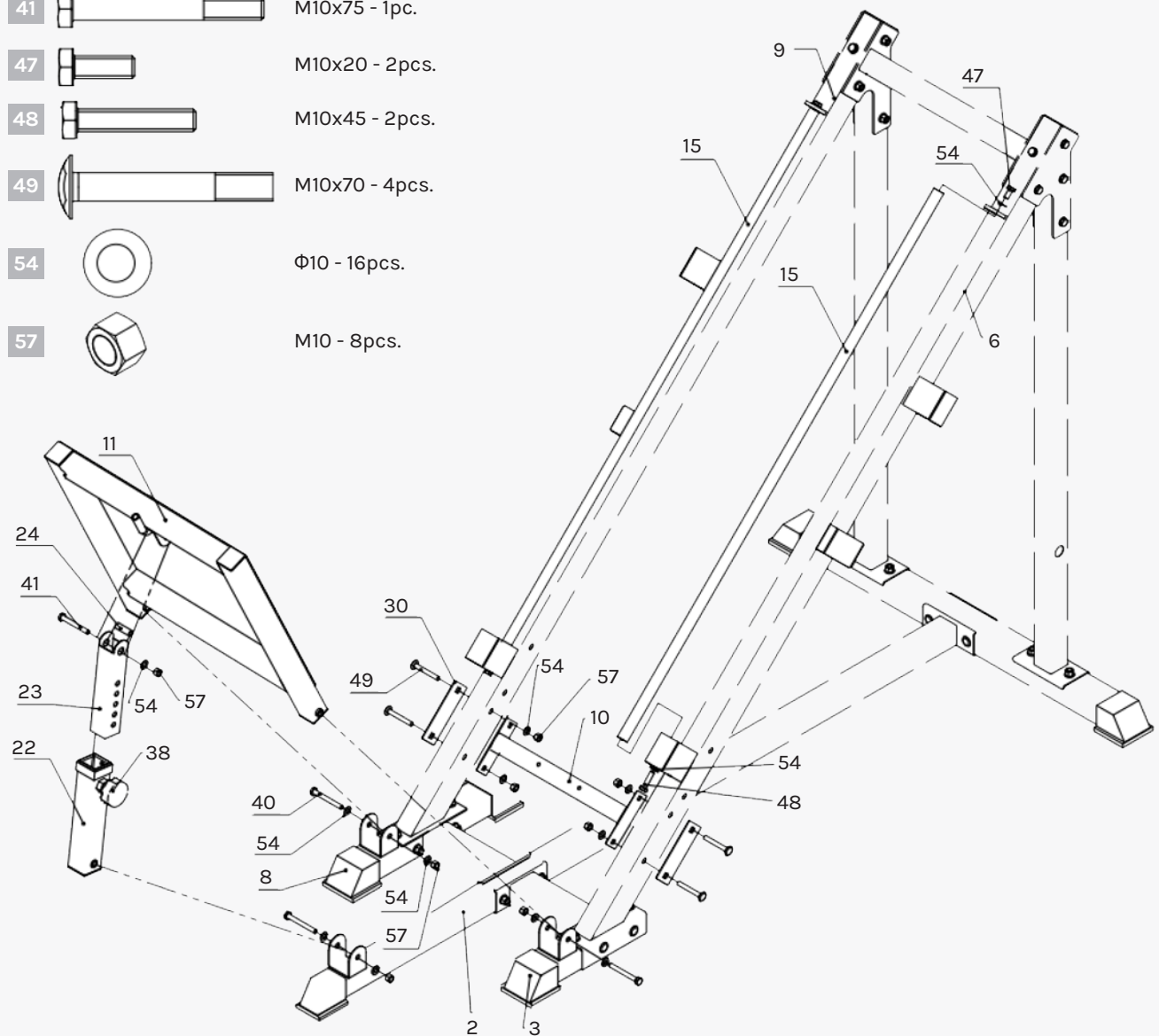

STEP 3

1. Connect and fix part 10# and two pieces of 30# plate to parts 6# and 9# using four pieces each of 49# bolt, 54# washer, and 57# nut. Do not fully tighten these connections yet.
2. Connect and fix part 11# to parts 3# and 8# using two pieces of 40# bolts, four pieces of 54# washers, and two pieces of 57# nuts. Keep these connections temporarily loose.
3. Connect and fix part 22# to part 2# using one piece of 40# bolt, two pieces of 54# washers, and one piece of 57# nut. Do not lock this connection yet.
4. Connect and fix parts 23# and 24# to part 11# using one piece of 41# bolt, two pieces of 54# washers, and one piece of 57# nut. Insert these into part 22# and adjust the height using part 38#. Ensure #38 is tightened before use.

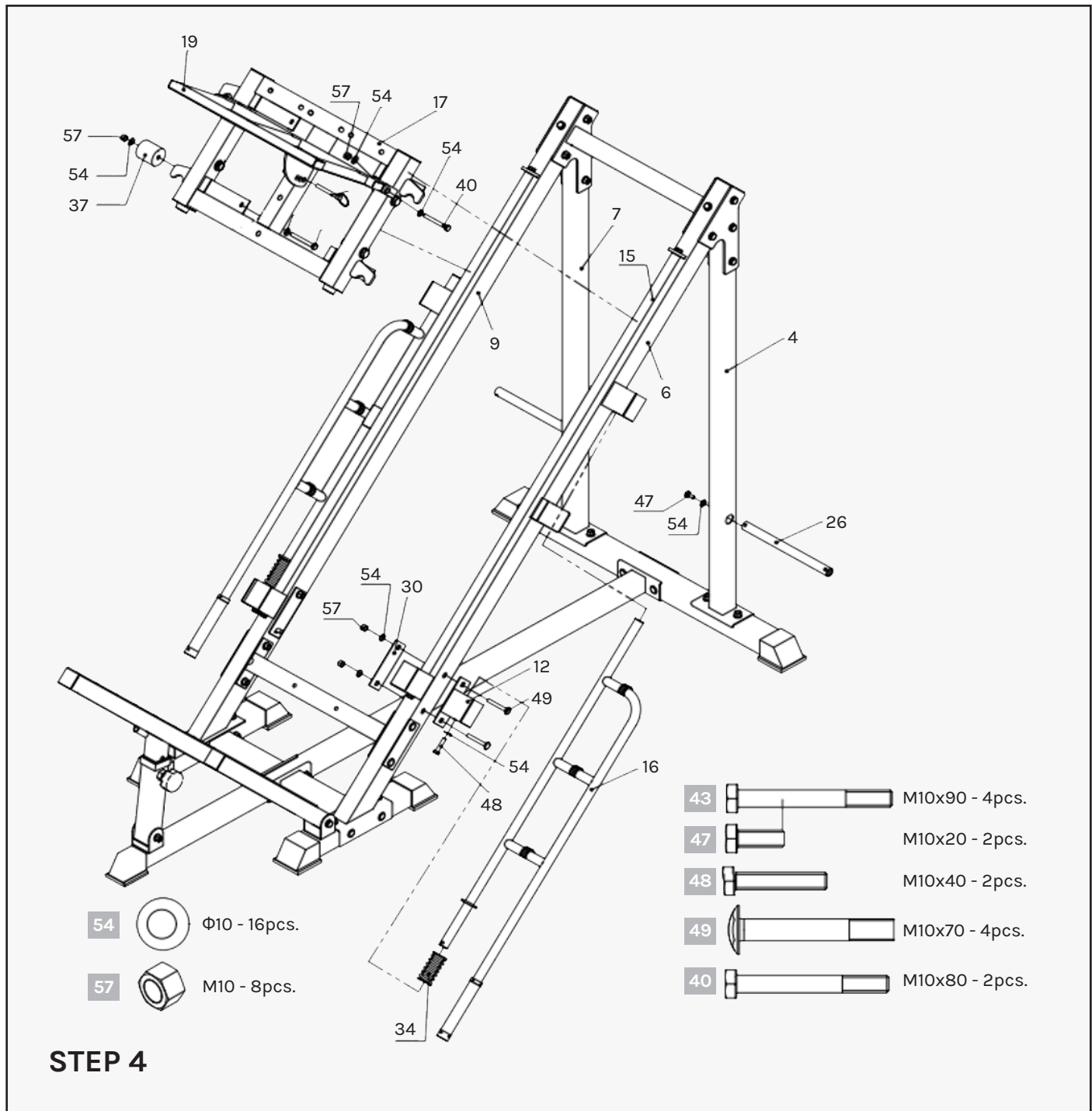

1. Install part 19# into the two small ear plates of part 17# using two pieces of 40# bolts, four pieces of 54# washers, and four pieces of 57# nut. Then, insert part 35# lock pin into the bottom sleeve holes of parts 19# and 17#.
2. Position the roller of part 17# on two parts of 15# slider, and fix part 37# rollers under parts 6# and 9# using four pieces of 43# bolts, eight pieces of 54#, and four pieces of 57#. Tighten the bolts until part 17# can slide freely up and down.
3. Insert two pieces of 16# into parts 6# and 9# (pull part 16# to the top), then install part 34#. Use two pieces of 30# plates, four pieces of 49# bolts, four pieces of 54# washers, and four pieces of 57# nuts to connect and secure two pieces of 12# on both sides of parts 6# and 9#. Finally, lower part 16# and connect and lock it with pieces 48# bolt and 54# washer.
4. Install two pieces of 26# rod on both sides of parts 4# and 7# and secure them with pieces 47# bolt and 54# washer.

54  $\Phi 10$ - 14pcs.

57  M10 - 10pcs.

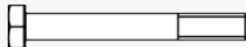
41  M10x75 - 4pcs.





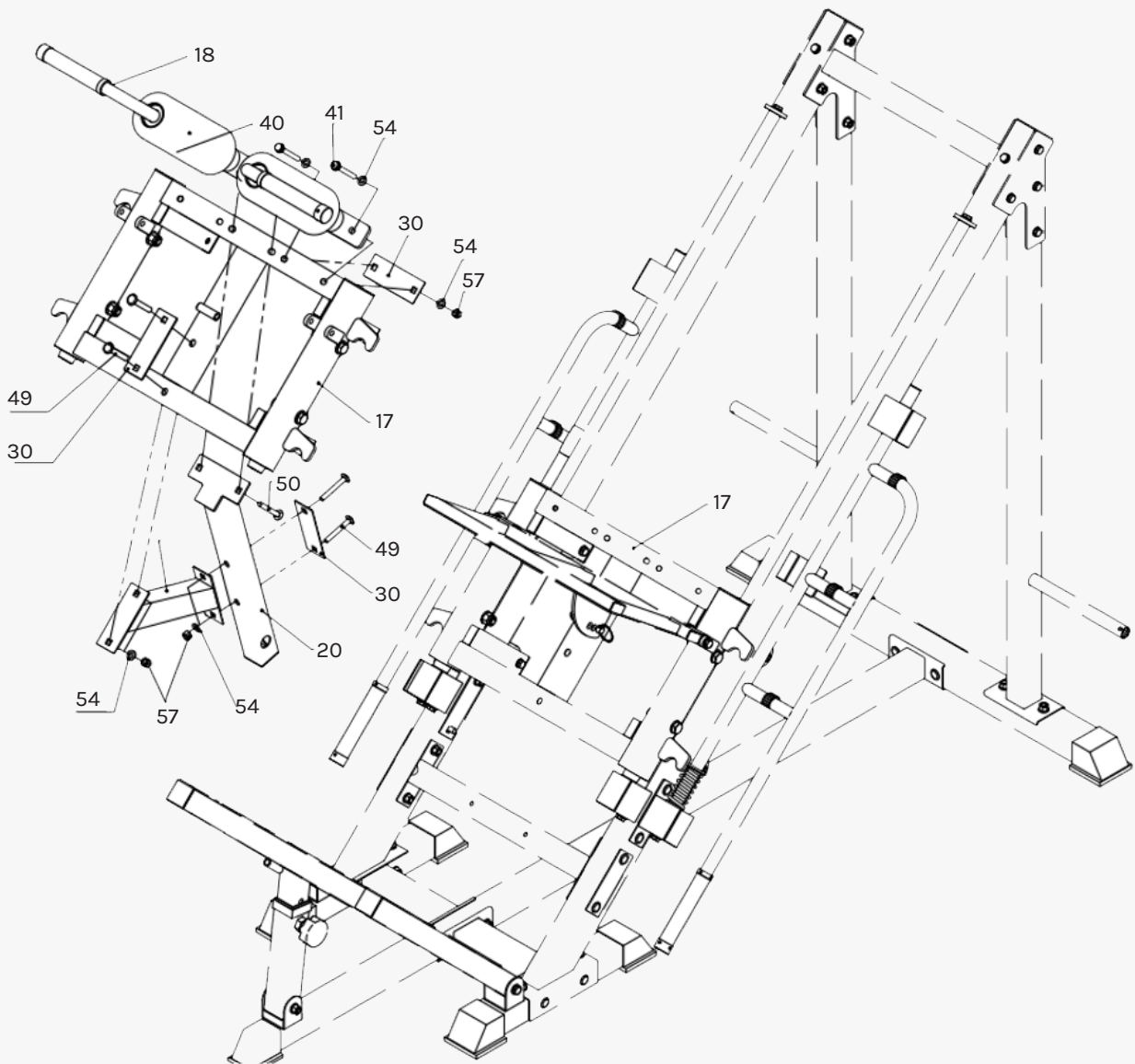

49  M10x70 - 4pcs.

50  M10x75 - 2pcs.



STEP 5

1. Install two pieces of 40# padding into part 18# arms, then connect and lock parts 18# and 17# using four pieces of 41# bolts, eight pieces of 54# washers, and four pieces of 57# nuts.
2. Connect and lock parts 20#, 18#, and 17# with two pieces of 50# bolts, two pieces of 54# washers, and two pieces of 57# nuts.
3. Connect and lock parts 21#, 17#, and 20# using two pieces of 30# plates, four pieces of 49# bolts, four pieces of 54# washers, and four pieces of 57# nuts.

54		Φ10 - 4pcs.
56		Φ8 - 4pcs.
45		M8x65 - 2pcs.
46		M8x20 - 2pcs.
47		M10x20 - 4pcs.
52		M6x16 - 4pcs.

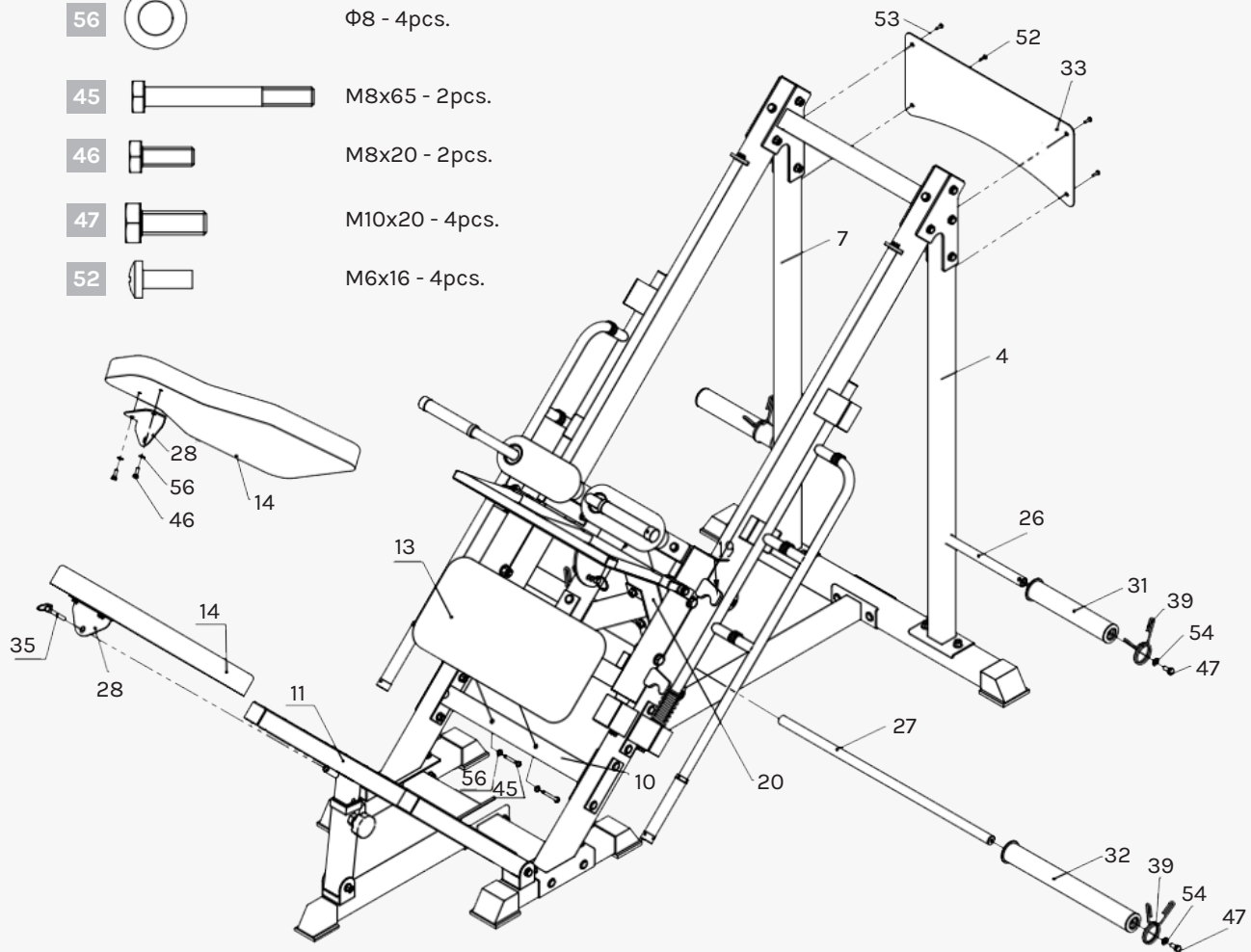

STEP 6

1. Connect parts 14# back cushion and 28# using two pieces of 46# bolts and two pieces of 56# washers. Then, use part 35# lock pin to pin part 14# into the sleeve of part 11#.
2. Fix part 13# onto part 10# using two pieces of 45# bolts and two pieces of 56# washers.
3. Secure part 33# back cover onto parts 4# and 7# using four pieces of 52# bolts.
4. Insert part 27# rod into part 20#, install two pieces of 32# Olympic sleeves and two pieces of 39# spring collars on the left and right ends, and connect and lock them using pieces 47# bolt and 54# washer.
5. Install two pieces of 31# Olympic sleeves and two pieces of 39# spring collars on both ends of the two pieces of 26# rod and secure them with pieces 47# bolt and 54# washer.
6. Tighten all the hardware.

IV. WARRANTY

AUSTRALIAN CONSUMER LAW

Many of our products come with a guarantee or warranty from the manufacturer. In addition, they come with guarantees that cannot be excluded under the Australian Consumer Law. You are entitled to a replacement or refund for a major failure and compensation for any other reasonably foreseeable loss or damage.

You are entitled to have the goods repaired or replaced if the goods fail to be of acceptable quality and the failure does not amount to a major failure. Full details of your consumer rights may be found at www.consumerlaw.gov.au.

Please visit our website to view our full warranty terms and conditions:
<http://www.lifespanfitness.com.au/warranty-repairs>

WARRANTY AND SUPPORT

Please email us at support@lifespanfitness.com.au for all warranty or support issues.

For all warranty or support related enquiries, please lodge a support ticket first by sending us an email.

LSG

WWW.LSGFITNESS.COM.AU