

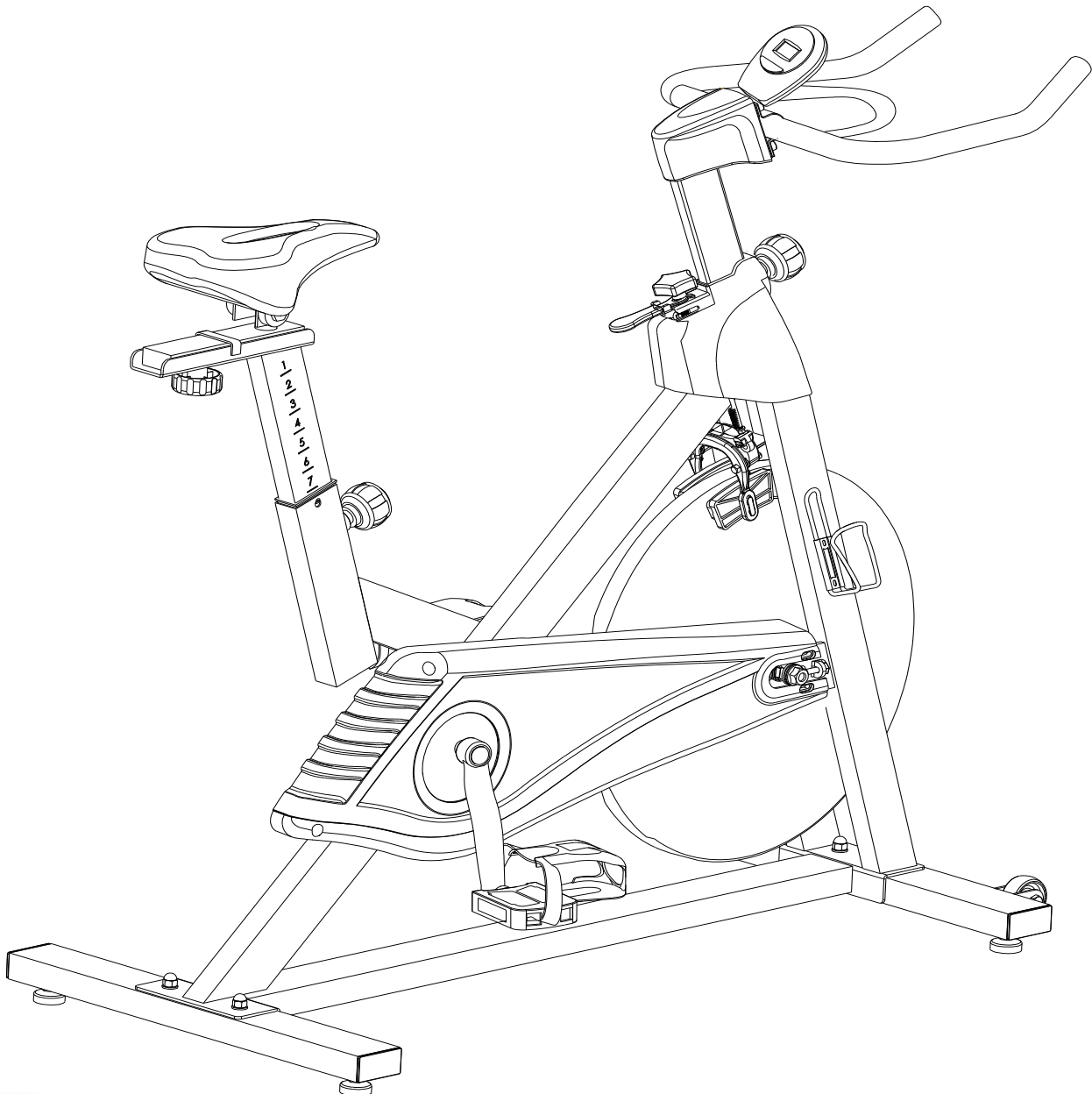

VISIT OUR BLOG FOR FITNESS TIPS,  
HEALTH TIPS, AND MUCH MORE!

[BLOG.LIFESPANFITNESS.COM.AU](http://BLOG.LIFESPANFITNESS.COM.AU)

## SP-320 OWNER'S MANUAL



Product may vary slightly from the item pictured due to model upgrades

Read all instructions carefully before using this product. Retain this owner's manual for future reference.

# TABLE OF CONTENTS

1.	IMPORTANT SAFETY INSTRUCTIONS_____	3
2.	EXPLODED DIAGRAM_____	5
3.	PARTS LIST_____	7
4.	ASSEMBLY INSTRUCTIONS_____	8
5.	ADJUSTMENT_____	13
6.	COMPUTER OPERATION_____	14
7.	EXERCISE GUIDE_____	15
8.	WARRANTY REGISTRATION _____	17

# 1. IMPORTANT SAFETY INSTRUCTIONS

**WARNING** - Read all instructions before using this machine.

It is important your spinning bike receives regular maintenance to prolong its useful life. Failing to regularly maintain your spinning bike may void your warranty.

1. Keep children and pets away from the machine at all times. Do not leave unattended children in the same room of the machine.
2. Handicapped or disabled persons should not use the machine without the presence of a qualified health professional or physician.
3. If the user experiences dizziness, nausea, chest pain, or any other abnormal symptoms, STOP the workout at once. CONSULT A PHYSICIAN IMMEDIATELY.
4. Before beginning training, remove all within a radius of 2 meters from the machine. DO NOT place any sharp objects around the spin bike.
5. Position the machine on a clear, level surface away from water and moisture. Place mat under the unit to help keep the machine stable and to protect the floor.
6. Use the machine only for its intended use as described in this manual. DO NOT use any other accessories not recommended by the manufacturer.
7. Assemble the machine exactly as the descriptions in the instruction manual.
8. Check all bolts and other connections before using the machine for the first time and ensure that the trainer is in the safe condition.
9. Hold a routine inspection of the equipment. Pay special attention to components which are the most susceptible to wear off, i.e. connecting points and wheels. The defective components should be replaced immediately. The safety level of this equipment can only be maintained by doing so. Please don't use the machine until it is repaired well.
10. NEVER operate the machine if it is not functioning properly.
11. This machine can be used for only one person's training at a time.

12. Do not use abrasive cleaning articles to clean the machine. Remove drops of sweat from the machine immediately after finishing training.
13. Always wear appropriate workout clothing when exercising. Running or aerobic shoes are also required.
14. Before exercising, always do stretching first.
15. The power of the machine increases with increasing the speed, and the reverse. The machine is equipped with adjustable knob, which can adjust the resistance.

## 2. EXPLODED DIAGRAM

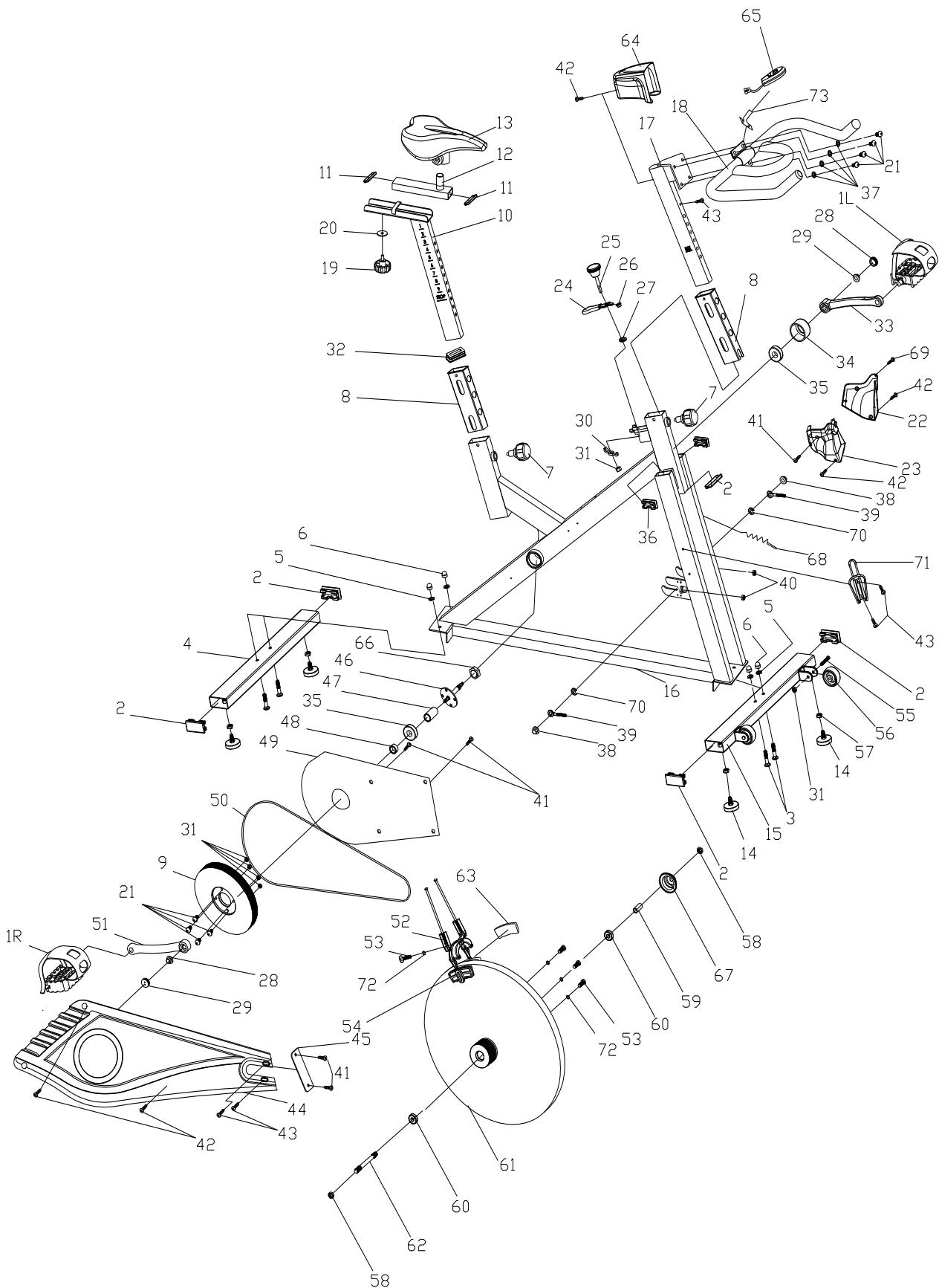

### 3. PARTS LIST

NO	NAME	QUANTITY	SPEC
1L	PEDAL L	1	JD-301 (9/16")
1R	PEDAL R	1	JD-301 (9/16")
2	END CAP1	5	60*30*1.5
3	CARRIAGE BOLT	4	GB/T 12-1988 M8*42
4	REAR STABILIZER	1	WELDING
5	FLAT WASHER	4	GB/T 95-2002 8
6	DOMED NUT	4	GB/T 802-1988 M8 (H=16mm)
7	SPRING ADJUSTMENT KNOB	2	φ50*82 (M16*1.5)
8	PLASTIC SLEEVE	2	53.5*23.5*1.5
9	BELT WHEEL	1	φ200*24
10	VERTICAL SEAT POST	1	WELDING
11	END CAP1	2	40*20*1.5
12	SEAT POST	1	WELDING
13	SEAT	1	DD-2681
14	STOPPER	4	φ32*37/(M8X25)
15	FRONT STABILIZER	1	WELDING
16	MAIN FRAME	1	WELDING
17	HANDLEBAR POST	1	WELDING
18	HANDLE BAR	1	WELDING
19	LOCKING KNOB	1	PE+Q235/φ52*47 (M8x15)
20	FLAT WASHER 1	1	φ32*φ8.2*2
21	BOLT	8	GB/T 70.2-2000 M8*15
22	LEFT PROTECT COVER	1	157*73*157 (85g)
23	RIGHT PROTECT COVER	1	156*80*174 (85g)
24	BRAKE KNOB	1	112*32*7
25	ADJUSTMENT KNOB	1	φ40*78
26	LITTLE PLASTIC RING	1	14*8*9
27	PLASTIC RING	2	φ20*φ9*3
28	FIXING NUT 1	2	GB/T 6177.2-2000 M10*1.25
29	CRANK END CAP	2	φ23*7.5
30	SHEET IRON	1	δ5
31	LOCK NUT	7	GB/T 889.1-2000 M8
32	END CAP2	1	53.5*23.5*1.5
33	LEFT CRANK	1	170*27
34	CRANK COVER	1	φ56*28
35	BEARING	2	6004ZZ
36	END CAP3	2	50*25*1.5

NO	NAME	QUANTITY	SPEC
37	SPRING WASHER	4	GB/T 859-1987 8
38	FIXING NUT 2	2	GB/T 802-1988 M12X1.25 (H=16mm)
39	FIXING BOLT	2	M6*54
40	NUT	2	GB/T 889.1-2000 M6
41	SCREW 1	13	GB/T 845-1985 ST4.2*19
42	SCREW 2	6	GB/T 15856.1-2002 ST4.2X19
43	SCREW 3	5	GB/845-85 ST4.8X13
44	OUTER CHAIN COVER	1	757*267*60.5 (550g)
45	LITTLE CHAIN COVER	1	108*37*3 (7g)
46	AXIS	1	φ20*162
47	LONG FIXING TUBE	1	φ25*φ20.5*41
48	SHORT FIXING TUBE	1	φ25*φ20.5*9
49	INNER CHAIN COVER	1	505*263*12 (220g)
50	BELT	1	5PK53
51	RIGHT CRANK	1	170*27
52	BRAKE	1	2PCS 130mm
53	BOLT	5	GB/T 70.1-2000 M6*20
54	BRAKE PLASTIC	2	82*41*19
55	BOLT	2	GB/T 5780-2000 M8*40
56	WHEEL	2	φ50*23
57	NUT	4	GB/T 41-2000 M8
58	FIXING NUT 2	2	M12X1.25 H=6
59	FIXING TUBE	1	φ16*φ12.1*35
60	BEARING	2	6001ZZ
61	FLYWHEEL	1	φ453*11(15KG)
62	FLYWHEEL SHAFT	1	φ12*160
63	WOOLLY BLOCK	2	78*38*14
64	HANDLEBAR COVER	1	115*89*75 (60g)
65	COMPUTER	1	HS-6065
66	FIXING NUT	2	27*M20*1 (5mm)
67	FLYWHEEL COVER	1	φ59*35
68	SENSOR	1	SR-202
69	SCREW 4	1	ST2.9*9.5
70	FLAT WASHER	2	GB/T 95-2002 12
71	BOTTLE HOLDER	1	φ6
72	SPRING WASHER	5	GB/T 859-1987 6
73	COMPUTER HOLDER	1	∅2.5

## 4. ASSEMBLY INSTRUCTIONS

### STEP 1: PREPARATION

- A. Before assembling make sure that you will have enough space around the item.
- B. Use the present tooling for assembly.
- C. Before assembly please check whether all needed parts are available (at the above of this instruction sheet you will find an exploded diagram with all single parts (marked with numbers) which this item consists of.

### STEP 2:

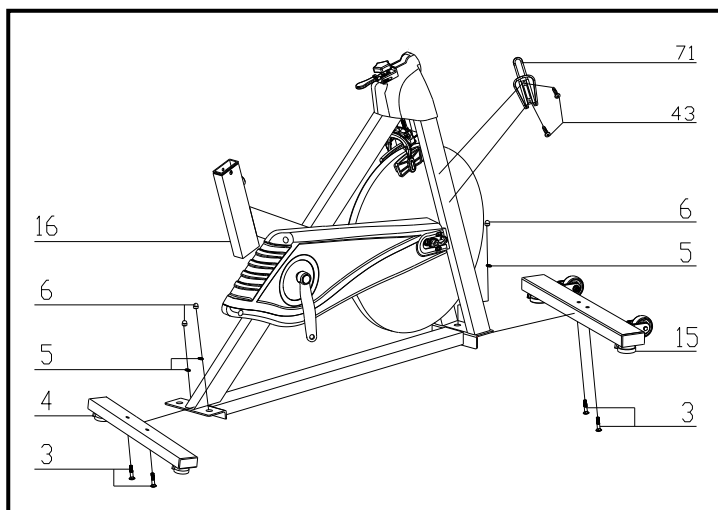

1. Attach the Front Stabilizer (pt.15) to the Main Frame (pt.16) using two sets of Ø8 Flat Washers (pt.5), M8 Domed Nut (pt.6) and M8\*42 Carriage bolt (3).
  2. Attach the Rear Stabilizer (pt.4) to the Main Frame (pt.16) using two sets of Ø8 Flat Washers (pt.5), M8 Domed Nut (pt.6) and M8\*42 Carriage bolt (3).
  3. Use the screw (Pt.43) to attach the bottle holder (Pt.71) to the main frame (Pt.16).
-



### STEP 3:

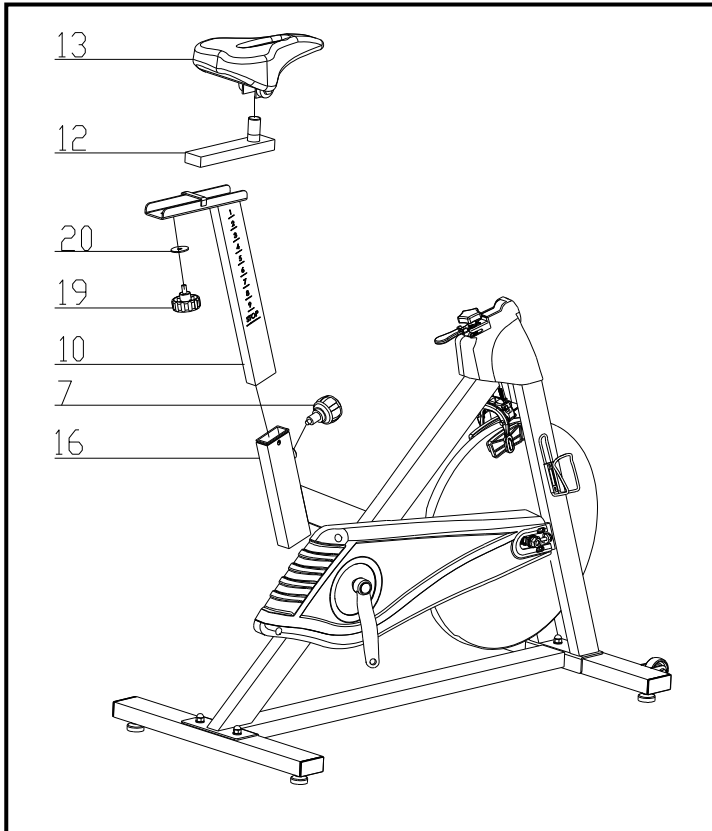

1. Slide the Vertical Seat Post (pt.10) into the seat post housing on the main frame (pt.16).
2. Slide the Seat Post (pt.12) into the Vertical Seat Post (pt.10).
3. Secure the Seat Post (pt.12) with the Locking Knob (19) and flat washer (20). You will have to loosen the knurled section of the Spring Adjustment Knob (pt.7), pull the knob back and then select and align holes for the desired height. Release the knob and retighten the knurled portion.
4. Attach the Seat (pt.13) to the Vertical Seat Post (pt.12) as shown, and tighten the bolts around the screws under the seat.

#### STEP 4:

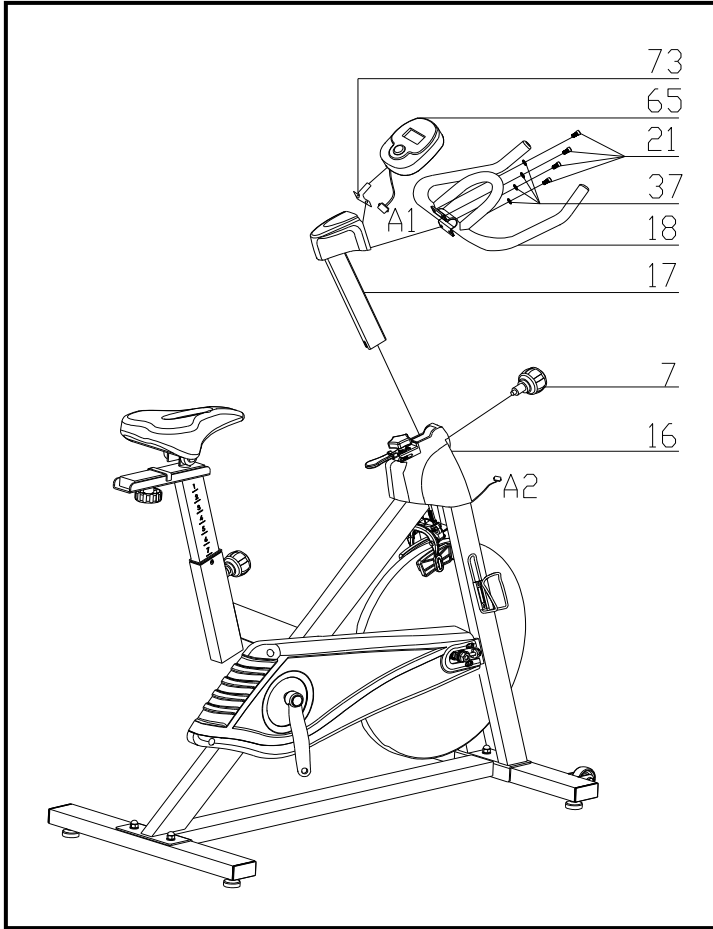

1. Slide the Handlebar Post (pt.17) into the handlebar post housing on the main frame.

You will have to loosen the knurled section of the Spring Adjustment Knob (pt.7), pull the knob back and then select and align holes for the desired height. Release the knob and retighten the knurled portion.

2. Remove the bolts and spring washer from the Handlebar Post (pt.17), then fix the Handlebar (pt.18) with 4pcs Ø8 the Spring Washer (pt.37) and M8\*15 the Bolt (pt.21).

*ATTENTION: The handlebar must be attached tightly*

3. Slide the Computer (pt.65) onto the Computer Holder (pt.73) connect the plug (A1&A2),

**STEP 5:**

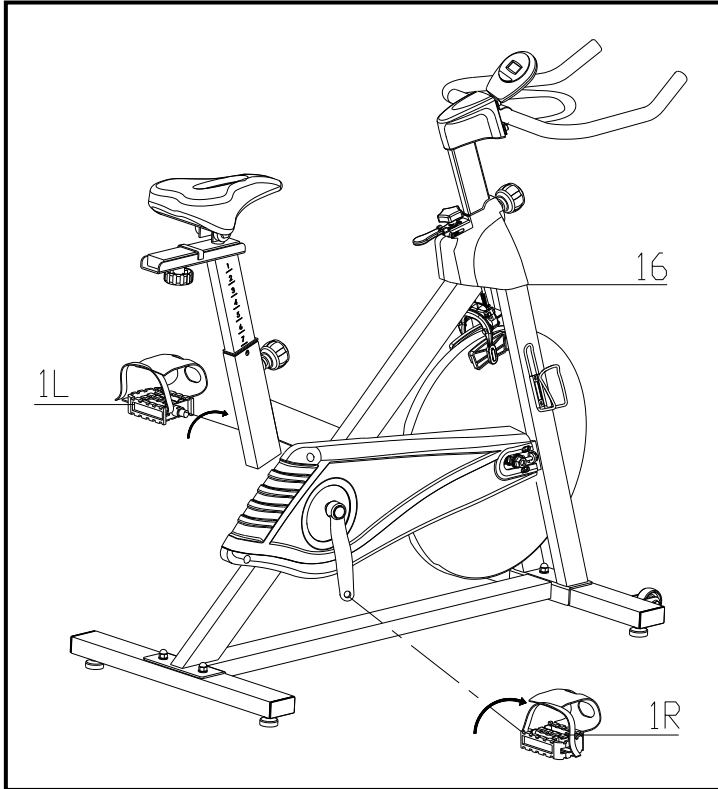

1. The Pedals (pt.1 L & pt.1 R) are marked "L" and "R" - Left and Right.  
Connect them to their appropriate crank arms. The right crank arm is on the right-hand side of the cycle as you sit on it.

*Note that the Right pedal should be threaded on clockwise and the Left pedal anticlockwise.*

*Inspect the tightness of the pedals on a regular basis. Using loose pedals will damage the thread.*

## TENSION ADJUSTMENT

Increasing or decreasing the tension allows you to add variety to your workout sessions by adjusting the resistance level of the bike.

To increase tension and increase resistance, turn the *Adjustment knob (#25)* to the *right*. (clockwise)

To decrease tension and decrease resistance, turn the *Adjustment knob (#25)* to the *left*. (counterclockwise)

## EMERGENCY BRAKE

Using the Emergency Brake Function:

The same knob that allows you to adjust the tension of the bike also doubles as the Emergency Brake. Use this safety feature in any situation where you would need to get off the bike and/or stop the bike's flywheel.

To use the Emergency Brake function in any situatio, firmly press down on the *Emergency Brake & Tension Control Knob (#30)*.

## 5. ADJUSTMENT

### **Vertical Seat Adjustment**

To adjust the seat height, slacken the spring knob on the vertical post stem on the main frame and pull back the knob. Position the vertical seat post for the desired height so that holes are aligned, then release the knob and retighten it.

### **Horizontal Seat Adjustment**

To move the seat forward in the direction of the handlebar or backwards away from it, loosen the adjusting knob and washer and pull the knob back. Slide horizontal seat post into desired position. Align holes and then retighten the adjusting knob.

### **Handlebar Height**

To adjust the handlebar height, slacken the spring knob and secondary knob and pull both knobs back. Slide the handlebar post along the housing on the main frame to the desired height and, with the holes aligned correctly, tighten the spring adjusting knob and then the secondary knob.

## 6. COMPUTER OPERATION

### PARAMETERS

Odometer (if applicable), Time, Speed, Distance and Calories. All workout parameters may be selected by the select key.

### FUNCTION

**POWER ON:** Pushing the button on the display will turn the display on and display the parameters of the previous workout.

**SCAN:** when the symbol "▶" points to SCAN, The monitor will display the functions listed below. Each function will remain on the screen for 4 seconds. The following modes will automatically cycle through respectively: TIME –SPEED-DISTANCE-CALORIES-PULSE

**TIME:** when the symbol "▶" points to TMR. The monitor will display total workout time.

**SPEED:** when the symbol "▶" points to SPD, The monitor will display the current speed in km/h.

**DISTANCE:** when the symbol "▶" points to DIST. The monitor will display the total workout distance in km.

**CALORIES:** when the symbol "◀" points to CAL. The monitor will display the total workout caloric consumption in K CAL.

**Reset:** Hold the button down for more than 3 seconds and all functions will reset to 0.

**SLEEP:** The display will automatically enter sleep mode if it does not receive a signal after 4 minutes of inactivity.

### SPECIFICATIONS

<b>FUNCTION</b>	Auto Scan	Every 4 seconds
	Elapsed Time	00:00~99:59
	Speed	0.0~99.9km/h
	Distance	0.00~99.99km
	Calorie	0.00~999.9kcal
Controller	4 bit single chip microprocessor	
Sensor	No-contact magnetic type	
Battery type	2 pcs of Size-AA or UM-3	
Operating temperature		0°~+40°C
Storage temperature		-10°~+60°C

## 7. EXERCISE GUIDE

**PLEASE NOTE:** Before beginning any exercise program, consult your physician. This is important especially if you are over the age of 45 or individuals with pre-existing health problems.

The pulse sensors are not medical devices. Various factors, including the user's movement, may affect the accuracy of heart rate readings. The pulse sensors are intended only as an exercise aid in determining heart rate trends in general.

Exercising is great way to control your weight, improving your fitness and reduce the effect of aging and stress. The key to success is to make exercise a regular and enjoyable part of your everyday life.

The condition of your heart and lungs and how efficient they are in delivering oxygen via your blood to your muscles is an important factor to your fitness. Your muscles use this oxygen to provide enough energy for daily activity. This is called aerobic activity. When you are fit, your heart will not have to work so hard. It will pump a lot fewer times per minute, reducing the wear and tear of your heart.

So as you can see, the fitter you are, the healthier and greater you will feel.

### Warm-up

Start each workout with 5 to 10 minutes of stretching and some light exercises. A proper warm-up increases your body temperature, heart rate and circulation in preparation for exercise. Ease into your exercise.

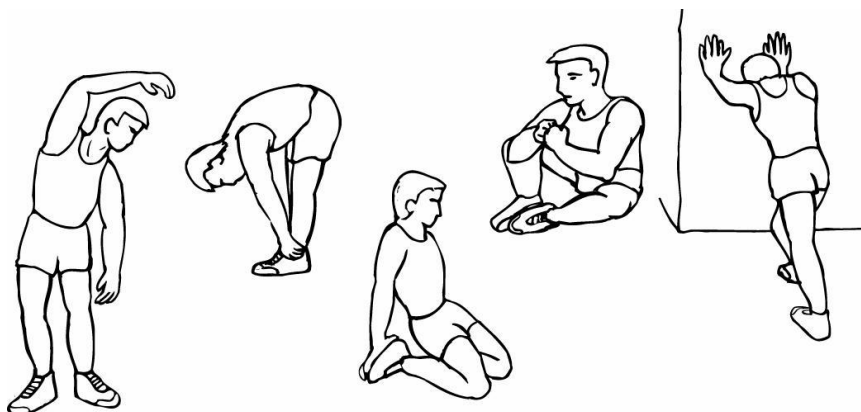

## Training Zone Exercise

After warming up, increase the intensity to your desired exercise program. Be sure to maintain your intensity for maximum performance. Breathe regularly and deeply as you exercise-never hold your breath.

## Cool Down

Finish each workout with a light jog or walk for at least 1 minute. Then complete 5 to 10 minutes of stretching to cool down. This will increase the flexibility of your muscles and will help prevent post-exercise problems.

## Workout Guidelines

### TARGET ZONE

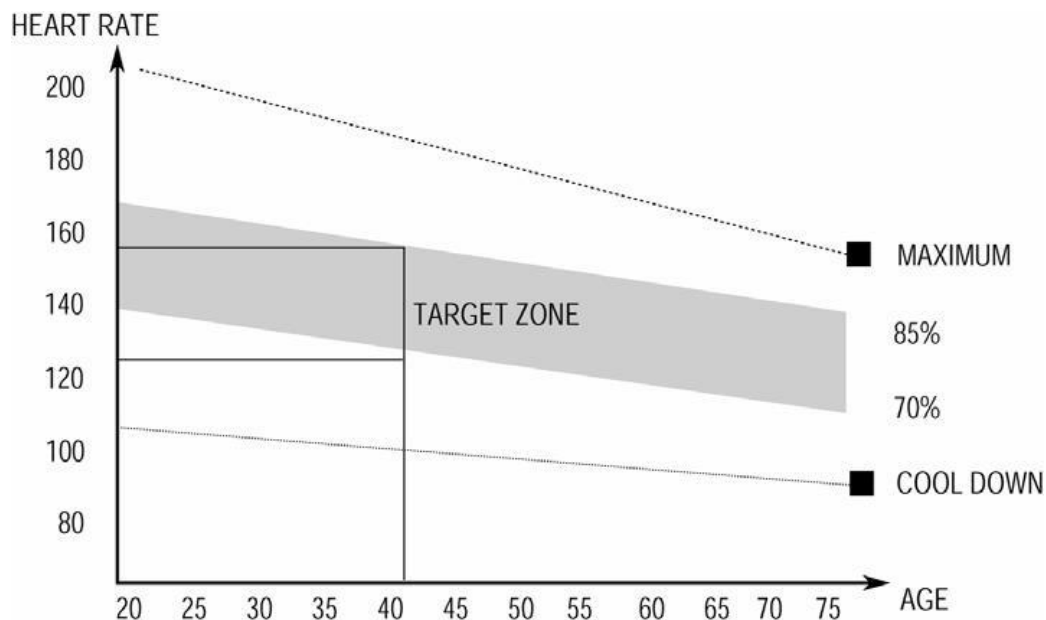

**THIS IS HOW YOUR PULSE SHOULD BEHAVE DURING GENERAL FITNESS EXERCISE.**

**REMEMBER TO WARM UP AND COOL DOWN FOR A FEW MINUTES.**

The most important factor here is the amount of effort you put in. The harder and longer you work, the more calories you will burn. Effectively this is the same as if you were training to improve your fitness, the difference is the goal.



## 8. WARRANTY

### AUSTRALIAN CONSUMER LAW

*Many of our products come with a guarantee or warranty from the manufacturer. In addition, they come with guarantees that cannot be excluded under the Australian Consumer Law. You are entitled to a replacement or refund for a major failure and compensation for any other reasonably foreseeable loss or damage.*

*You are entitled to have the goods repaired or replaced if the goods fail to be of acceptable quality and the failure does not amount to a major failure. Full details of your consumer rights may be found at [www.consumerlaw.gov.au](http://www.consumerlaw.gov.au)*

Please visit our website to view our full warranty terms and conditions:

<http://www.lifespanfitness.com.au/warranty-repairs>

Please email us through [support@lifespanfitness.com.au](mailto:support@lifespanfitness.com.au) for all warranty or support issues.

### **Warranty and Support:**

Please email us at [support@lifespanfitness.com.au](mailto:support@lifespanfitness.com.au) for all warranty or support issues.

For all warranty or support related enquiries an email must be sent first before contacting us via other means.