

LSG

ACE M2 TREADMILL OWNER'S MANUAL

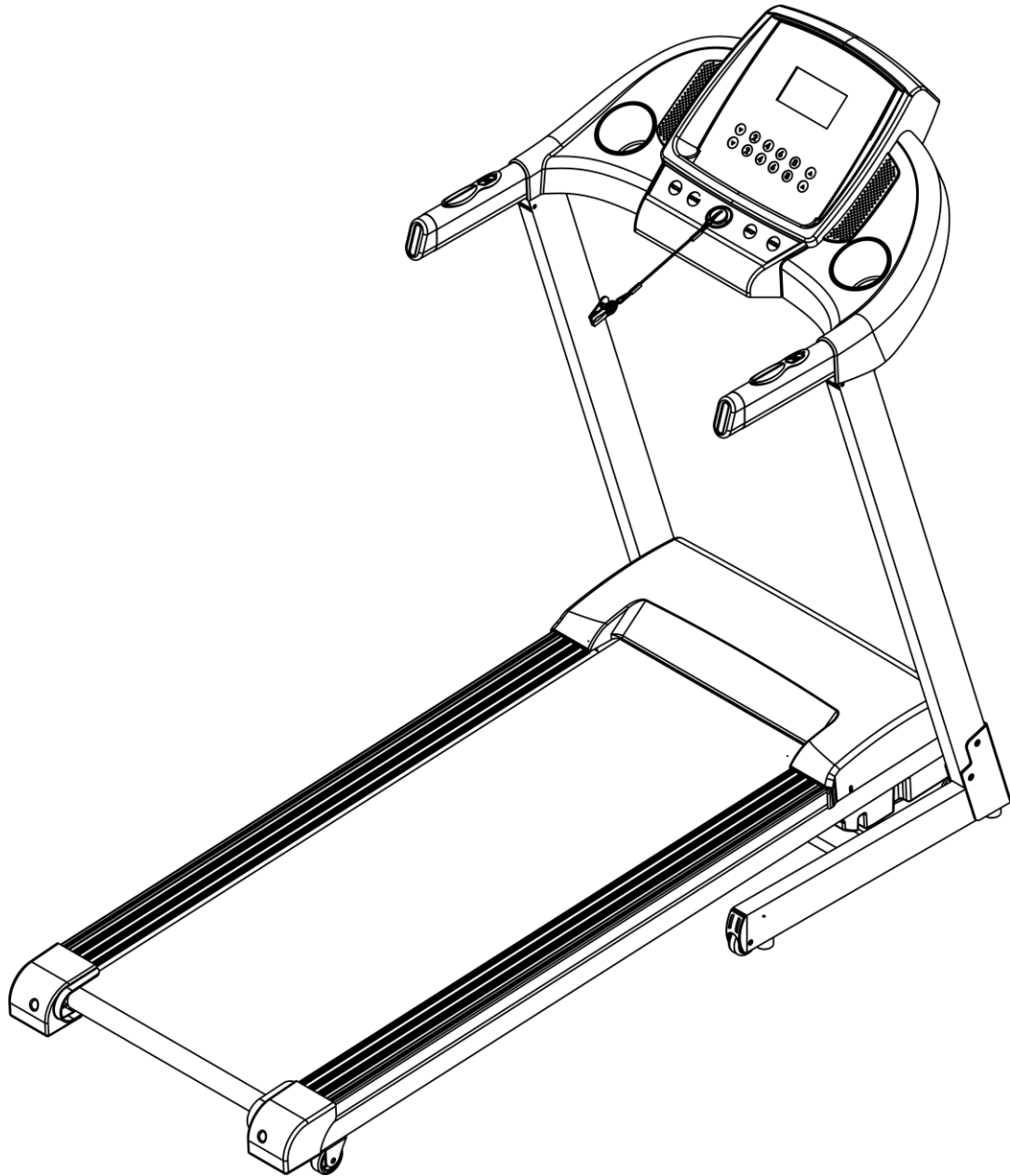

Product may vary slightly from the item pictured due to model upgrades

Read all instructions carefully before using this product. Retain this owner's manual for future reference.

NOTE: This manual may be subject to updates or changes. Up to date manuals are available through our website at www.lifespanfitness.com.au

TABLE OF CONTENTS

1.	IMPORTANT SAFETY INSTRUCTIONS_____	3
2.	IMPORTANT ELECTRICAL INFORMATION_____	5
3.	IMPORTANT OPERATING INSTRUCTIONS_____	6
4.	ASSEMBLY INSTRUCTIONS_____	7
5.	FOLDING INSTRUCTIONS_____	11
6.	OPERATION GUIDE WITH PROGRAM CHART_____	12
7.	EXERCISE GUIDE_____	16
8.	MAINTENANCE INSTRUCTIONS_____	18
9.	EXPLODED DIAGRAM_____	26
10.	PARTS LIST_____	27
11.	TROUBLE SHOOTING GUIDE_____	28
12.	WARRANTY_____	31

1. IMPORTANT SAFETY INSTRUCTIONS

WARNING - Read all instructions before using this treadmill.

It is important your treadmill receives regular maintenance to prolong its useful life. Failing to regularly maintain your treadmill may void your warranty.

Danger – To reduce the risk of electric shock disconnect your treadmill from the electrical outlet prior to cleaning and/or service work.

DO NOT USE AN EXTENSION CORD: DO NOT ATTEMPT TO DISABLE THE GROUNDED PLUG BY USING IMPROPER ADAPTERS OR IN ANY WAY MODIFY THE CORD SET.

- Install the treadmill on a flat level surface with access to a 220-240 volt (50/60Hz), grounded outlet.
- Do not operate treadmill on deeply padded, plush or shag carpet. Damage to both carpet and treadmill may result.
- Do not block the rear of the treadmill. Provide a minimum of 1 metre clearance between the rear of the treadmill and any fixed object.
- Place your unit on a solid, level surface when in use
- When running, make sure the plastic clip is fastened on your clothing. It is for your safety, should you fall or move too far back on the treadmill.
- Keep hands away from all moving parts.
- Never operate the treadmill if it has a damaged power cord or plug. When damaged, these must be replaced by the manufacturer, its service agent or similarly qualified persons in order to avoid a hazard.
- Keep the cord away from heated surfaces.
- Do not operate where aerosol spray products are being used or where oxygen is being administered. Sparks from the motor may ignite a highly gaseous environment.
- Never drop or insert any object into any openings.
- The treadmill is intended for in-home use only and is not suitable for commercial environments.

- To disconnect, turn all controls to the off position, remove the safety key, and then remove the plug from the outlet.
- The pulse sensors are not medical devices. Various factors, including the user's movement, may affect the accuracy of heart rate readings. The pulse sensors are intended only as exercise aids in determining heart rate trends in general.
- Use the handrails provided; they are for your safety.
- Wear proper shoes. High heels, dress shoes, sandals or bare feet are not suitable for use on your treadmill. Quality athletic shoes are recommended to avoid leg fatigue.
- Before undertaking any type of exercise program, it is recommended that you consult a doctor.
- Injuries to health may result from incorrect or excessive training.
- This appliance is not intended for use by persons (including children) with reduced physical, sensory or mental capabilities, or lack of experience and knowledge, unless they have been given supervision or instruction concerning use of the appliance by a person responsible for their safety.
- **WARNING** heart rate monitoring systems may be inaccurate. If you feel faint stop exercising immediately.
- Children should not be allowed on or around the equipment, even when not in use.
- Children should be supervised to ensure that they do not play with this machine
- Loose-fitting clothing or jewellery that could become an entanglement hazard should not be worn.
- Training shoes should be worn when using the equipment.
- Equipment must be used on a level and stable surface.
- All fixings should be checked before the equipment is used.
- All literature relating to the use of the equipment should be retained for future reference.
- Recommended operating temperature: 5-40°C

Remove the safety key after use to prevent unauthorized treadmill operation.

2. IMPORTANT ELECTRICAL INFORMATION

WARNING!

- Route the power cord away from any moving part of the treadmill including the elevation mechanism and transport wheels.
- NEVER remove any cover without first disconnecting AC power.
- NEVER expose this treadmill to rain or moisture. This treadmill is not designed for use outdoors, near a pool, or in any other high humidity environment.
- This is a high-power item; please do not share the same outlet with other high power machines such as, fridges, air conditioning etc. Please choose an outlet exclusively for the machine and make sure the fuse is 10A.

3. IMPORTANT OPERATING INSTRUCTIONS

- Understand that changes in speed and incline do not occur immediately. Set your desired speed on the display console and release the adjustment key. The display will obey the command gradually.
- Use caution while participating in other activities while walking on your treadmill, such as watching television, reading, etc. These distractions may cause you to lose balance or stray from walking in the centre of the belt; which may result in serious injury.
- In order to prevent losing balance and suffering unexpected injury, never mount or dismount the treadmill while the belt is moving. This unit starts with at a very low speed. Simply standing on the belt during slow acceleration is proper after you have learned to operate this machine.
- Always hold on to handrail while making control changes.
- A safety key is provided with this machine. Remove the safety key will stop the walking belt immediately; the treadmill will shut off automatically. Inserting the safety key will reset the display.
- Do not use excessive pressure on console control keys. They are precision set to function properly with little finger pressure.
- Replace any defective components immediately. The machine must be kept out of use until repaired.
- Belt wear-in period: all treadmills make a certain type of thumping noise due to the belt riding over the rollers, especially new treadmills. This noise will diminish over time, although may not completely go away. The belt will stretch over time, causing it to ride smoother over the rollers.

4. ASSEMBLY INSTRUCTIONS

PARTS LIST

NO.	DES.	Specification	Nos.	NO.	DES.	Specification	Nos.
1	Main Frame		1	71	Safety Key		1
12	5# Allen Wrench		1	64	Lock Washer	8	6
51	Bolt	M8*16	4	72	Oil Bottle		1
70	Bolt	M8*42	2	79	MP3 Wire	Optional	1

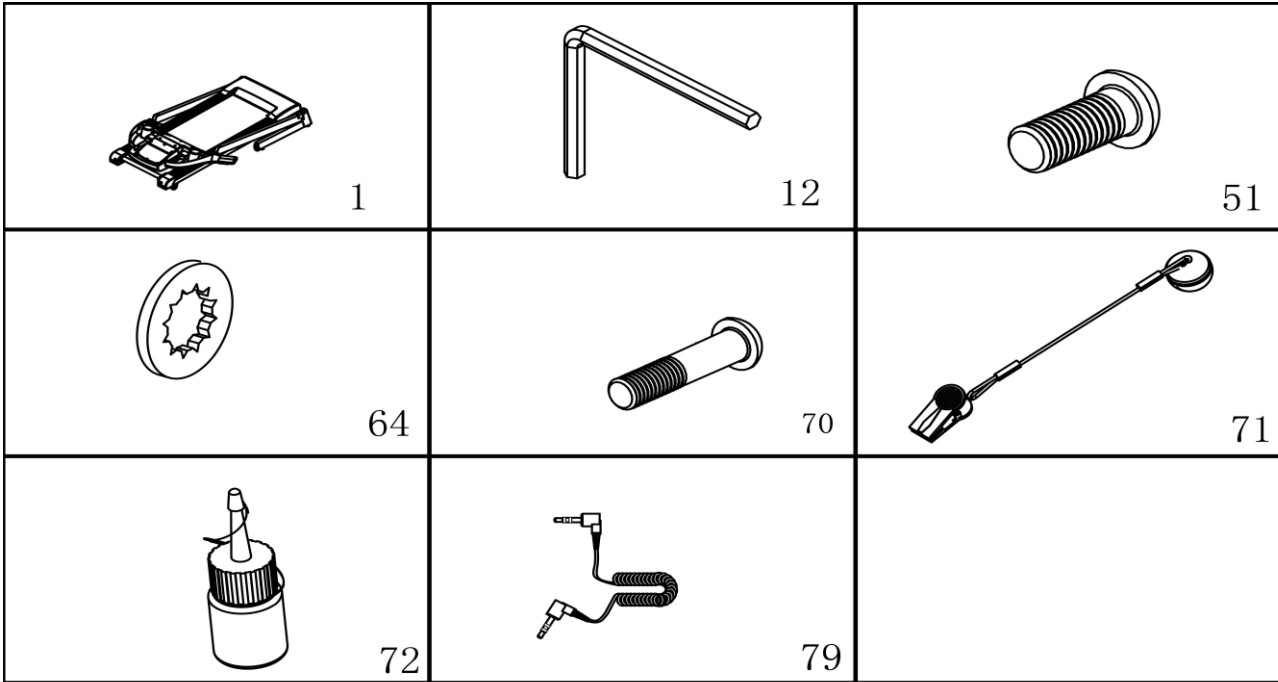

ASSEMBLY TOOLS:

5# Allen Wrench 5mm: 1pc

WARNING: Do not connect power until assembly is complete

STEP 1:

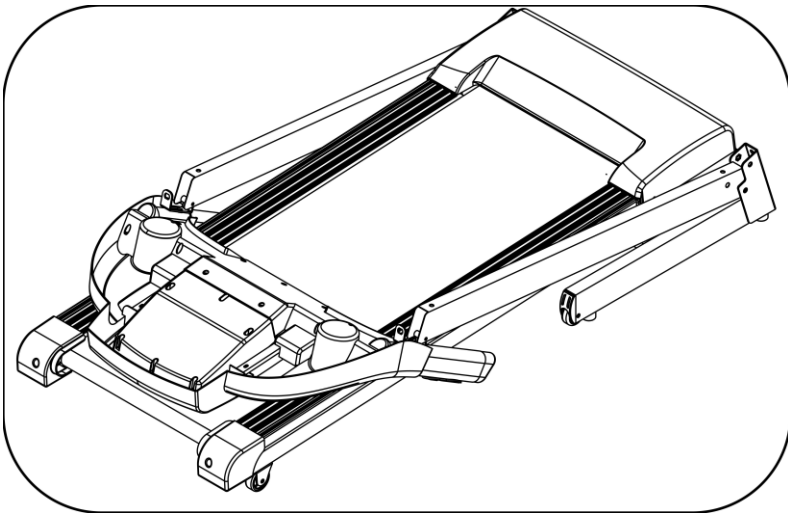

1. Open the carton
2. Extract the parts listed above
3. Place the Main Frame flat onto level ground

STEP 2:

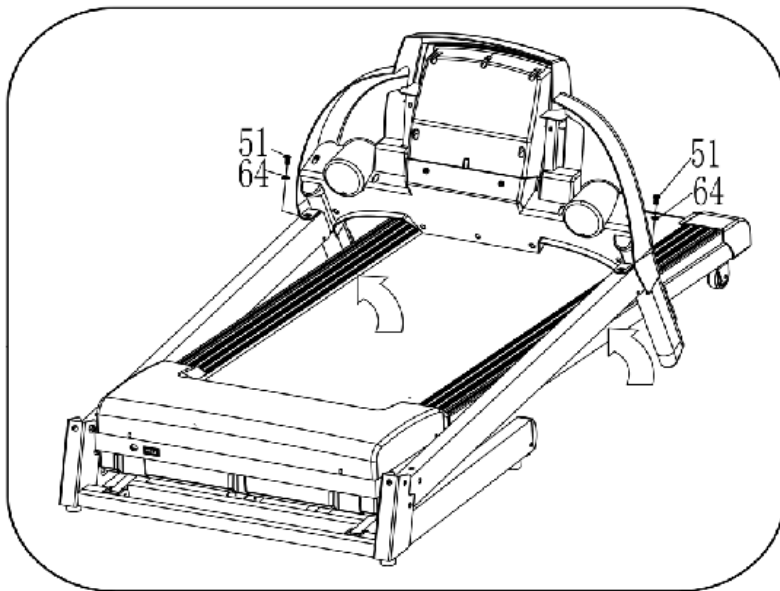

1. Hold on the Computer frame and use the 5# Allen wrench (12), bolt (51) and lock washer (64), fix the computer frame onto the right and left upright.

Note: Take care not to damage the wires inside the uprights during assembly. Support the Computer with your hands to prevent it from falling down unexpectedly and causing injury.

STEP 3:

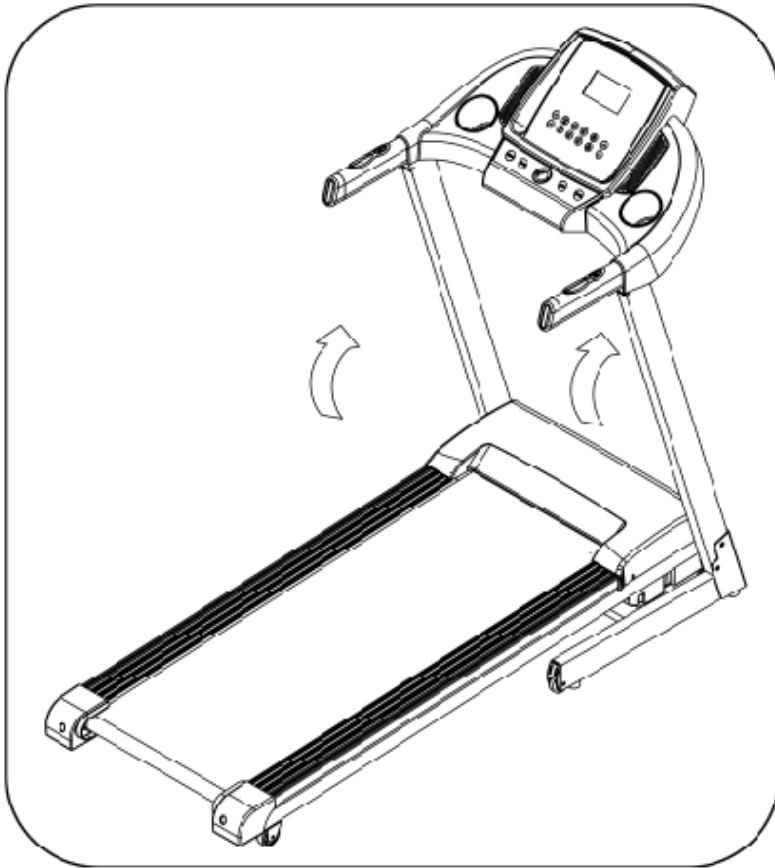

1. Pull up the Computer and L&R uprights.

Note: Ensure that you continually support the uprights with hands to avoid them falling down and cause injury.

STEP 4:

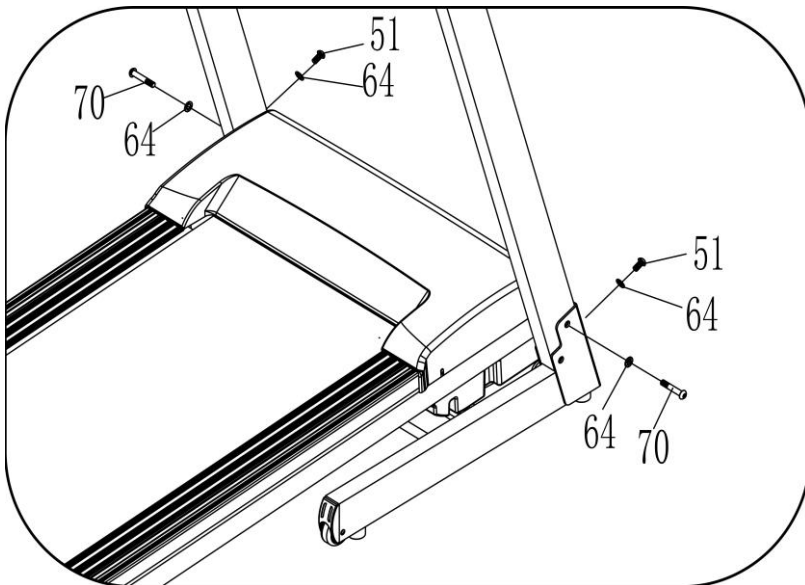

1. Using 5# Allen wrench (12), screw the Bolt M8*45 (70) through the Lock Washer (64). Using these, secure the right upright to the Main Frame.
2. Using the 5# Allen wrench, screw the M8*16 Bolt (51) through the Lock Washer (64). Using these, further secure the right upright tubes to the main frame.
3. Repeat the above two steps for the opposing side

Note: Continue to support the upright tubes during this step.

STEP 5:

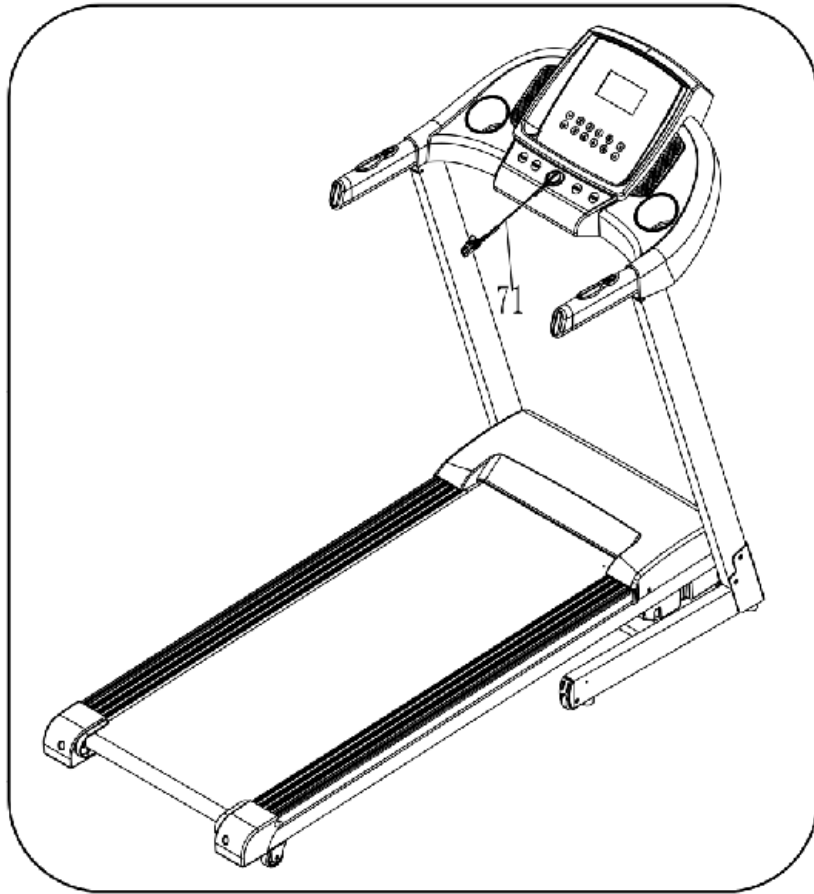

1. Place the safety key (71) on the computer.

5. FOLDING INSTRUCTIONS

Folding:

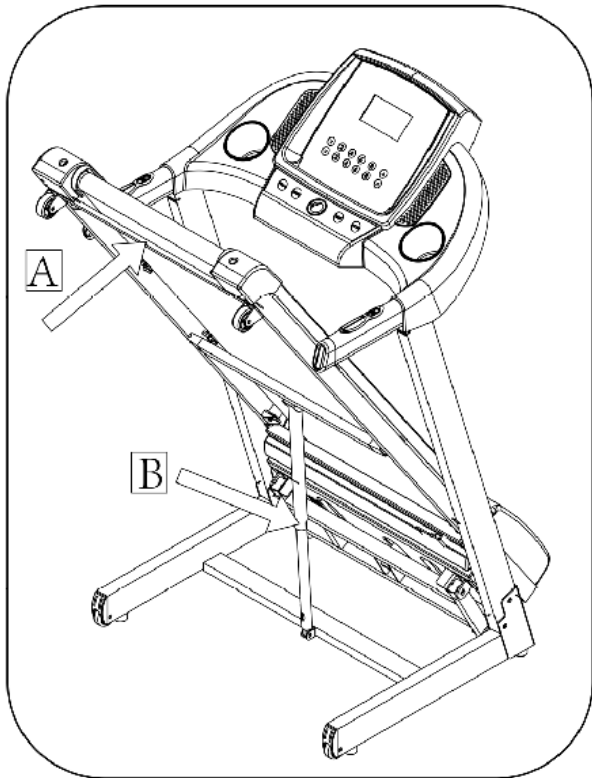

Place your hand on position (A), then pull up the base frame until you hear the click sound emitted when the air pressure bar (B) is locked into the round tube.

Unfolding:

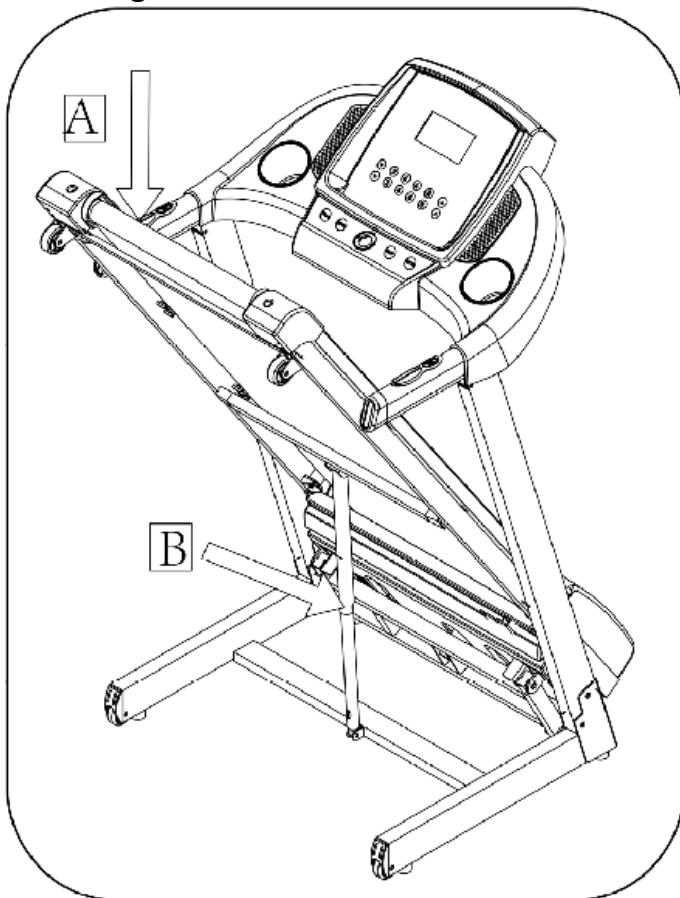

Whilst supporting position A with our hand, gently push the marked area on the air pressure bar with your foot. The base frame will descend gradually. (Please keep people and any pets away the machine during descent)

Video Tutorial Available at:

<http://youtu.be/TcuPbJ7KuxQ>

Lifespan Fitness YouTube Channel:

<http://www.youtube.com/user/treadmillsvideos>

6. OPERATION GUIDE WITH PROGRAM CHART

1. OVERVIEW

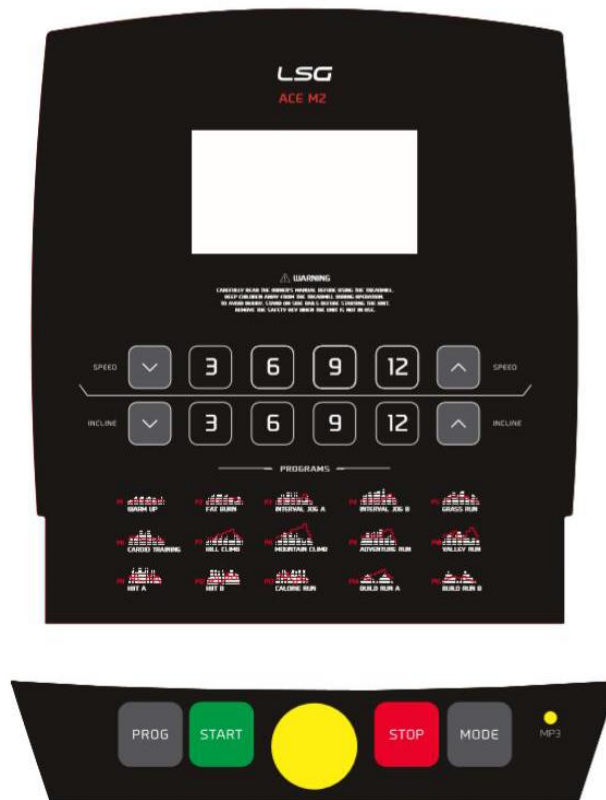

1. BUTTON FUNCTION

“START” button: Press this button to start the machine, the machine will run at the lowest speed or at the speed of default program after 3 seconds time count down;

“STOP button: Press this button to stop the machine, the machine will slow the speed still stop.

“PROG” button: Press this button to choose program from manual mode—P1----P15---FAT;

“MODE” button: When machine in standby state, press this button to choose the mode: manual mode-time count down mode-distance count down mode-calories count down;

SPEED ▲, ▼: Adjust the speed. Press the button to adjust the speed when running, and adjust the data when stop;

INCLINE ▲, ▼: Adjust the incline. Press the button to adjust the incline when running, and adjust the data when stop;

SPEED (3/6/9/12): Adjust the speed quickly.

INCLINE (3/6/9/12): Adjust the incline quickly.

2. SAFETY KEY FUNCTION

Pull out the safety key, the treadmill will stop quickly. All normal operation must be in the state of safety key locked.

3. HEART BEAT TEST

When holding the hand pulse by two hands, the pulse window will show your heart beat after 5 seconds.

In order to get the heart beat more correct, please test when the machine stop, and holding the hand pulse more than 30 seconds. The heart beat data is just for reference, cannot be as the medical data.

4. RUNNING DATA DISPLAY AND SETTING RANGE

	INITIAL DATE	INITIAL SETTING DATE	SET RANGE	SHOW RANGE
PROGRAM TIME	0:00	30:00	5:00-99:00	0:00~99:59
SPEED(KM/H)	0.0	1.0	1.0—18.0	0—18.0
INCLINE	0.0	0	0-15%	0-15%
DISTANCE	0.0	1.0	0.5—99.9	0.0—99.9
CALORIES	0	50	10—999	0—999
MODE TIME	0:00	15:00	5:00-99:00	0:00~99:59

5. PROGRAMS TABLE:

TIME PROGRAM		Setting time/20= interval running time																			
		1	2	3	4	5	6	7	8	9	10	11	12	13	14	15	16	17	18	19	20
P01	SPEED	2	3	3	4	5	3	4	5	5	3	4	5	4	4	4	2	3	3	5	3
	INCLINE	1	1	2	2	2	3	3	3	2	2	1	2	2	1	1	3	3	2	2	2
P02	SPEED	2	4	4	5	6	4	6	6	6	4	5	6	4	4	4	2	2	5	4	2
	INCLINE	1	2	2	2	2	3	3	2	2	2	2	2	3	3	3	4	4	3	2	2
P03	SPEED	2	4	4	6	6	4	7	7	7	4	7	7	4	4	4	2	4	5	3	2
	INCLINE	2	3	3	2	2	3	3	3	2	2	2	2	4	4	4	6	6	3	2	2
P04	SPEED	3	5	5	6	7	7	5	7	7	8	8	5	9	5	5	6	6	4	4	3
	INCLINE	2	3	3	2	2	3	3	3	2	2	2	2	4	4	4	6	6	3	2	2
P05	SPEED	2	4	4	5	6	7	7	5	6	7	8	8	5	4	3	3	6	5	4	2
	INCLINE	3	3	3	4	4	5	5	5	4	4	4	4	5	5	3	3	3	2	2	2
P06	SPEED	2	4	4	4	5	6	8	8	6	7	8	8	6	4	4	2	5	4	3	2
	INCLINE	3	5	5	5	4	4	4	3	3	3	3	4	4	4	3	3	3	4	3	2
P07	SPEED	2	3	3	3	4	5	3	4	5	3	4	5	3	3	3	6	6	5	3	3
	INCLINE	4	4	4	4	3	3	6	6	6	7	7	8	8	9	9	6	6	5	4	4
P08	SPEED	2	3	3	6	7	7	4	6	7	4	6	7	4	4	4	2	3	4	4	2
	INCLINE	4	5	5	5	6	6	6	7	8	9	9	9	10	10	10	12	12	8	6	3
P09	SPEED	2	4	4	7	7	4	7	8	4	8	9	9	4	4	4	5	6	3	3	2
	INCLINE	5	5	5	6	6	6	4	4	6	6	5	5	8	8	9	9	9	7	4	2
P10	SPEED	2	4	5	6	7	5	4	6	8	8	6	6	5	4	4	2	4	4	3	3
	INCLINE	5	6	6	6	7	5	8	8	4	4	4	5	5	8	8	10	10	8	6	3
P11	SPEED	2	5	8	10	7	7	10	10	7	7	10	10	5	5	9	9	5	5	4	3
	INCLINE	4	5	3	2	6	6	2	2	2	2	2	4	5	6	3	2	5	5	2	0
P12	SPEED	3	4	9	9	5	9	5	8	5	9	7	5	5	7	9	9	5	7	6	3
	INCLINE	1	2	3	2	3	5	5	0	0	2	3	5	7	3	3	5	6	5	3	3
P13	SPEED	3	6	7	5	9	9	7	5	5	7	9	5	8	5	9	5	9	9	4	3
	INCLINE	3	3	5	6	5	3	3	7	5	3	2	0	0	5	5	3	2	3	2	1
P14	SPEED	2	2	4	5	6	5	4	3	2	1	2	3	4	5	6	5	4	3	2	1
	INCLINE	4	4	4	4	3	3	6	6	6	7	7	8	8	9	9	6	6	5	4	4
P15	SPEED	2	4	6	8	6	6	4	4	2	2	2	4	6	8	6	6	4	4	2	2
	INCLINE	3	3	3	4	4	5	5	5	4	4	4	4	5	5	3	3	3	2	2	2

6. USER DEFINED PROGRAM

There are three program U1, U2, U3 for user defined.

6.1. Setting

Press program key to select any U1-U3 for self-setting program. Then press MODE key enter to self-condition, the speed & incline window show the value of the segment. By plus or minus to adjust the speed and incline paragraph. Press the MODE button to confirm and at the same time setting the next period. After finishing the 20th time setting. You can storage all data till next time you get a new setting,

This data won't lost by outage.

6.2. Start

A: Under standby mode, press “PROG” continuous to set user defined program (U01-U03) directly. When time setting is ready, press “START” to start.

B: After setting user program and time, press START to start running.

6.3. Setting manual

Each program divide into 20 time segments equally. Only finish the setting each time segment for speed and incline, you can start the treadmill.

7. BODY FAT TEST

Press ‘PROGRAM’ button under ready condition, till ‘FAT’ show in the speed window. ‘FAT’ is body fat test mode. Press ‘MODE’ to choose parameter ‘SEX / AGE / HEIGHT / WEIGHT’, and TIME/DIST window will show “F1”, “F2”, “F3”, and “F4”. When set each parameter, press SPEED ▲/▼ to adjust the data, and CAL/PULSE window will show the data and press ‘MODE’ button to finish, and the window will show “F5” and “---” enter into ready condition. Hold the handle pulse with two hands, it will show your BMI data after 5 seconds.

7.1 Data Display and Set Range

Parameter Type	default	Setting range	mark
SEX (F1)	1 (MALE)	1—2	1=MALE 2=FEMALE
AGE (F2)	25	10—99	
HEIGHT (F3)	170 CM	100—200 CM	
WEIGHT (F4)	70KG	20—150KG	
RESULT (F5)	AS BELOW SHOWING		

7.2 BMI Reference

(BMI)	
FAT ≤19	Under weight
19<FAT ≤25	Normal weight
25<FAT ≤29	Over weigh
FAT≥30	Obesity

7. EXERCISE GUIDE

PLEASE NOTE: Before beginning any exercise program, consult your physician. This is important especially if you are over the age of 45 or individuals with pre-existing health problems.

The pulse sensors are not medical devices. Various factors, including the user's movement, may affect the accuracy of heart rate readings. The pulse sensors are intended only as an exercise aid in determining heart rate trends in general.

Exercising is great way to control your weight, improving your fitness and reduce the effect of aging and stress. The key to success is to make exercise a regular and enjoyable part of your everyday life. The condition of your heart and lungs and how efficient they are in delivering oxygen via your blood to your muscles is an important factor to your fitness. Your muscles use this oxygen to provide enough energy for daily activity. This is called aerobic activity. When you are fit, your heart will not have to work so hard. It will pump a lot fewer times per minute, reducing the wear and tear of your heart. So as you can see, the fitter you are, the healthier and greater you will feel.

Warm-up

Start each workout with 5 to 10 minutes of stretching and some light exercises. A proper warm-up increases your body temperature, heart rate and circulation in preparation for exercise. Ease into your exercise.

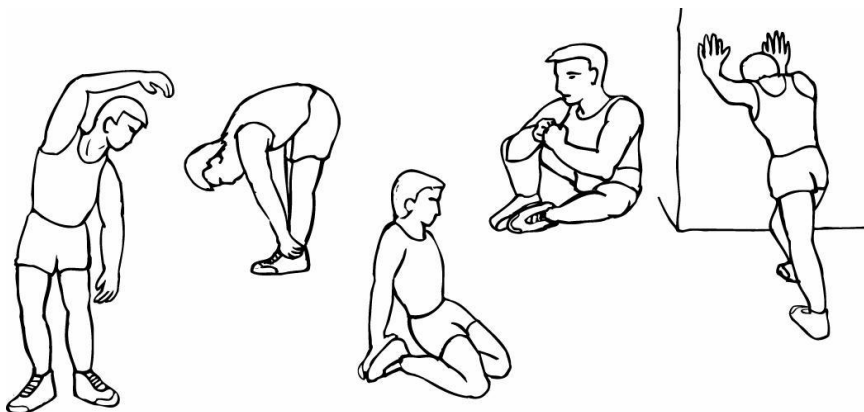

Training Zone Exercise

After warming up, increase the intensity to your desired exercise program. Be sure to maintain your intensity for maximum performance. Breathe regularly and deeply as you exercise.

Cool Down

Finish each workout with a light jog or walk for at least 1 minute. Then complete 5 to 10 minutes of stretching to cool down. This will increase the flexibility of your muscles and will help prevent post-exercise problems.

Workout Guidelines

TARGET ZONE

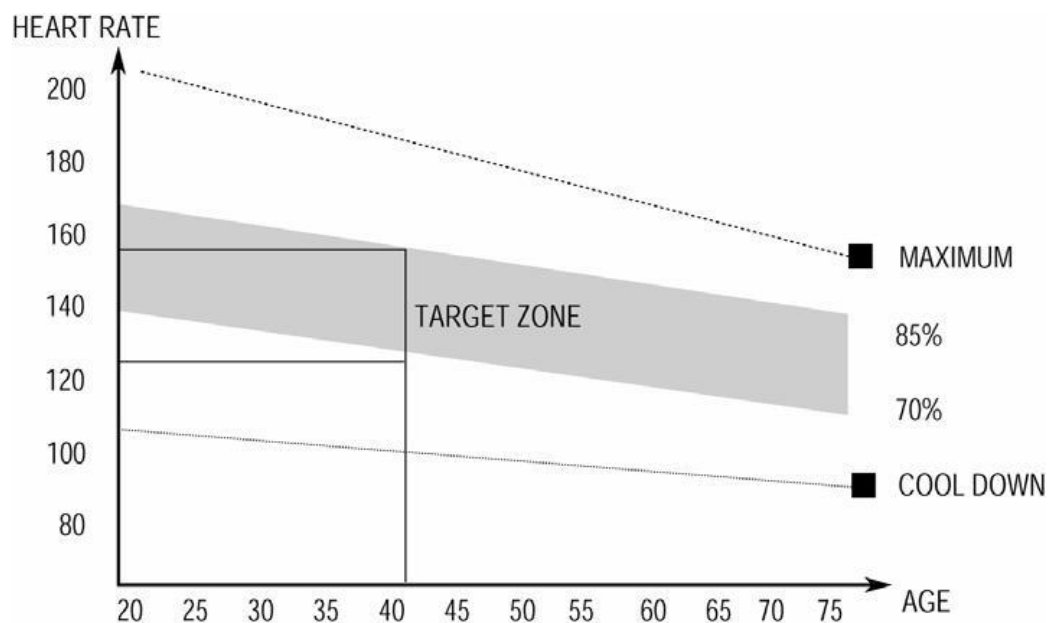

This is how your pulse should behave during general fitness exercise. Remember to warm up and cool down for a few minutes.

The most important factor here is the amount of effort you put in. The harder and longer you work, the more calories you will burn.

8. MAINTENANCE INSTRUCTIONS

Reasonable cleaning/lubricating should be made to extend the life time of this unit. Performance is maximized when the belt and mat are kept as clean as possible.

WARNING: THE MAT/DECK FRICTION MAY PLAY A MAJOR ROLE IN THE FUNCTION AND LIFE OF YOUR TREADMILL AND THAT IS WHY WE RECOMMEND YOU CONSTANTLY LUBRICATE THIS FRICTION POINT TO PROLONG THE USEFUL LIFE OF YOUR TREADMILL. FAILING TO DO THIS MAY VOID YOUR WARRANTY.

WARNING: UNPLUG POWER CORD BEFORE MAINTENANCE

WARNING: STOP TREADMILL BEFORE FOLDING

1. General Cleaning

- Use a soft, damp cloth to wipe the edge of the belt and the area between the belt edge and frame. A mild soap and water solution along with a nylon scrub brush will clean the top of the textured belt. This task should be done once a month. Allow to dry before using.
- On a monthly basis, vacuum underneath your treadmill to prevent dust build up. Once a year, you should remove the black motor shield and vacuum out dirt that may accumulate.

2. General Care

- Check parts for wear before use.
- Pay particular attention to the fixing knobs and make sure they are tight.
- Always replace the mat if worn and any other defective parts.
- If in doubt do not use the treadmill and contact us.

TAKE CARE TO PROTECT CARPETS AND FLOOR in case of leakages. This product is a machine that contains moving parts which have been greased / lubricated and could leak.

3. Belt/Deck/Roller Lubrication

The mat/deck friction may play a major role in the function and life of your treadmill and that is why we recommend you constantly lubricate this friction point to prolong the useful life of your treadmill. You should apply lubrication after approximately the first 30 hours of operation. We recommend lubrication of the deck according to the following timetable:

- Light use (less than 3 hours per week) every 6 months
- Medium use (3-5 hours a week) every 3 months
- Heavy use (more than 5 hours per week) every 6-8 weeks

See below procedures for lubricating:

1. Use a soft, dry cloth to wipe the area between the belt and deck.
2. Spread lubricant onto the inside surface of belt and deck evenly (make sure the machine is turned off and power is disconnected).

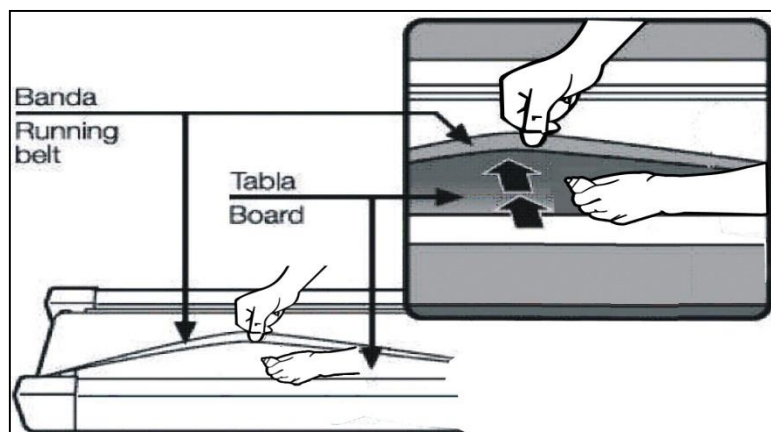

3. Periodically lubricate the front and rear rollers to keep them at their peak performance. If the treadmill belt/deck/roller is kept reasonably clean it is possible to expect over 1200 hours before relubricating is necessary.

Video Tutorial Available at:
<http://youtu.be/cP9NtFHfWlc>

Lifespan Fitness Channel:
<http://www.youtube.com/user/treadmillsvideos>

4. How to check the running mat for proper lubrication:

1. Disconnect the main power supply.
2. Fold the treadmill up into the storage position.
3. Feel the underside surface of the running mat.

If the surface is slick when touched, then no further lubrication is needed.

If the surface is dry to the touch, apply a suitable silicone lubricant.

We recommend that you use a silicone based spray to lubricate your treadmill. This can be purchased directly from us or any hardware store.

Video Tutorial Available at:
<http://youtu.be/cP9NtFHfWlc>

Lifespan Fitness Channel:
<http://www.youtube.com/user/treadmillsvideos>

5. Adjusting the Running Belt

Place treadmill on a level surface. Run treadmill at approximately 4km/h, checking the running condition.

If the belt has drifted to the **right**:

Whilst the treadmill is running at 4km/h, carefully turn the **right** adjusting bolt 1/4 turn **clockwise**. Then monitor treadmill until the belt centers. Repeat until the belt correctly centers. See *Picture A*

If you have over adjusted the belt and it drifts to the right, carefully turn the **right** adjusting bolt **anticlockwise** until the belt centers.

If the belt has drifted to the **left**:

Whilst the treadmill is running at 4km/h, carefully turn the **left** adjusting bolt 1/4 turn **clockwise**. Then monitor treadmill until the belt centers. Repeat until the belt correctly centers. See *Picture B*

If you have over adjusted it, carefully turn the **left** adjusting bolt **anticlockwise** and until the belt centers.

To adjust the **tightness** of the belt:

Turn the treadmill off. Turn both the left and right adjusting bolts 1/4 turn clockwise. Repeat until the belt correctly tightens.

See *Picture C*

If the belt is over tightened, simply do the opposite to loosen.

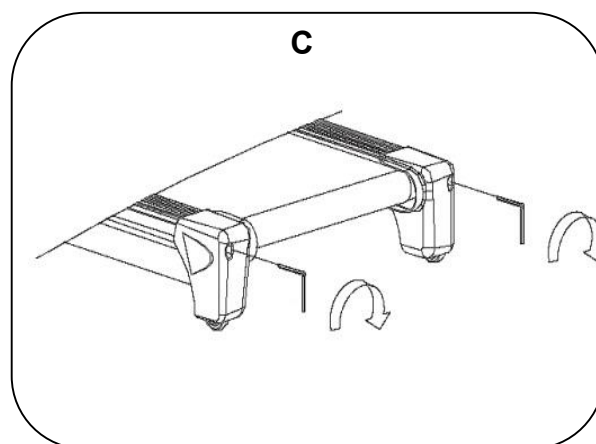
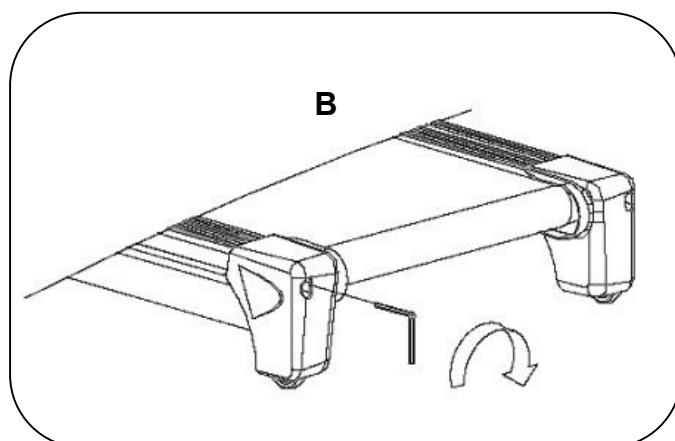
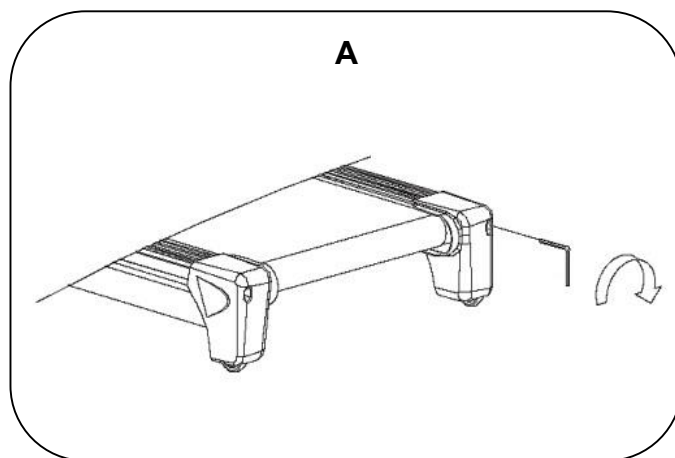

NOTE: When properly tightened, you should be able to peel the very edge of the side of the belt up approximately 2 inches. However this is a rough reference and not all treadmills are the same. Some treadmills that have longer belts may give different measurements for correct belt tightness.

Simply, if the belt begins to slip during use, this is an indication that the belt still needs tightening.

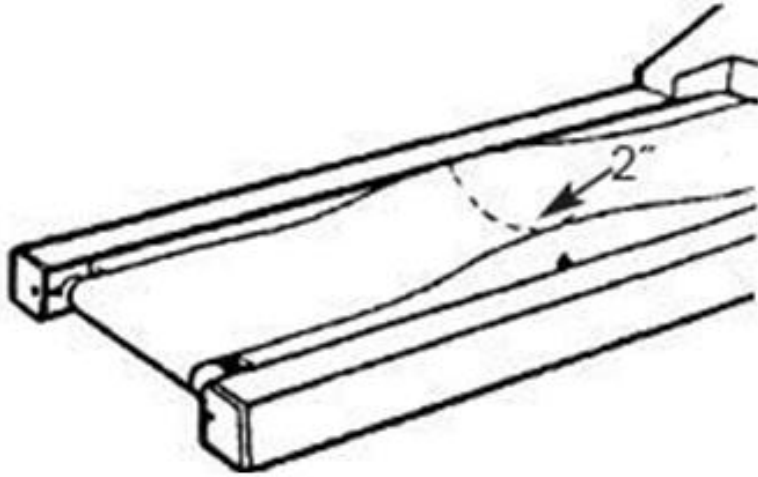

Video Tutorial Available at:
<http://youtu.be/vllsamTSvA>

Lifespan Fitness Channel:
<http://www.youtube.com/user/treadmillsvideos>

6. Replacing Motor Brushes

After extended use, the motor brushes in your treadmill motor will wear down, and this can lead to motor failure. It is important that you maintain your motor by replacing the brushes on either side of the motor when they are worn down. We recommend that you check your motor every 1000 hours of usage.

IMPORTANT: Before beginning the replacement of your motor brush, ensure that the treadmill is off and unplugged from the electrical socket.

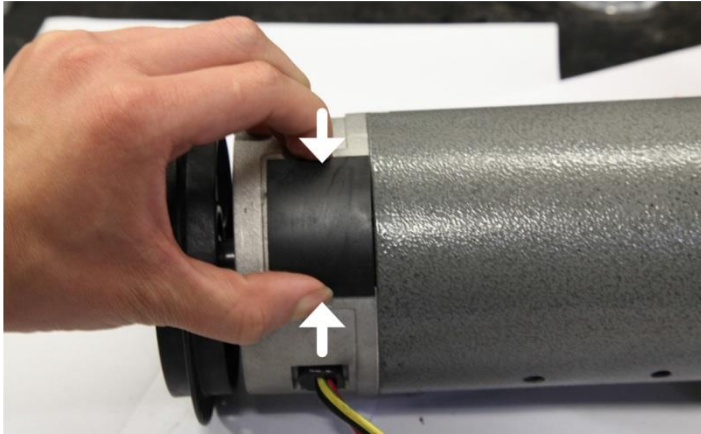

1. Remove the cover from the motor by squeezing it from the sides.

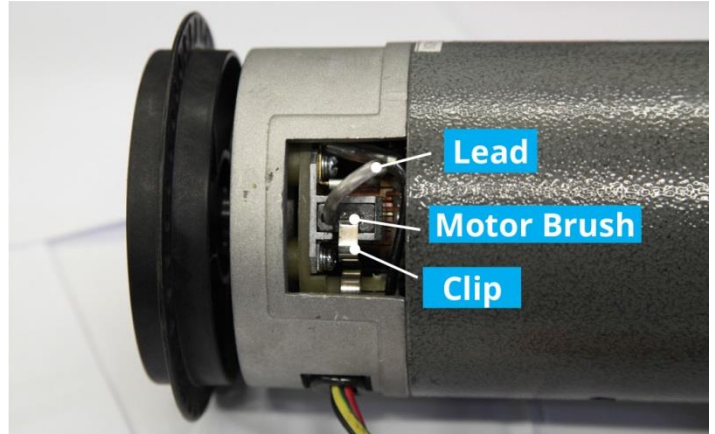

2. You'll find the motor brush held in with a clip, with the lead plugged in.

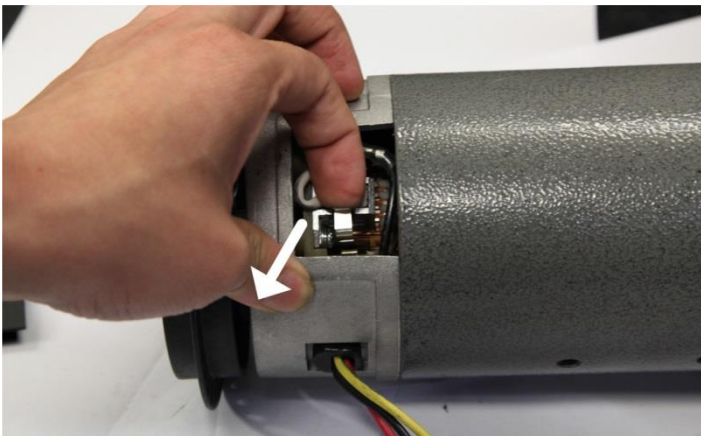

3. Pull the clip out from its position.

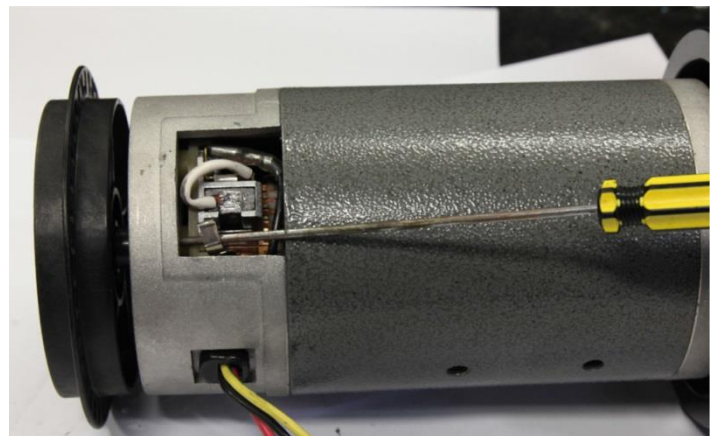

4a. Hold the clip out of the way with a screwdriver or similar object. Keep the screwdriver in this position until step 9.

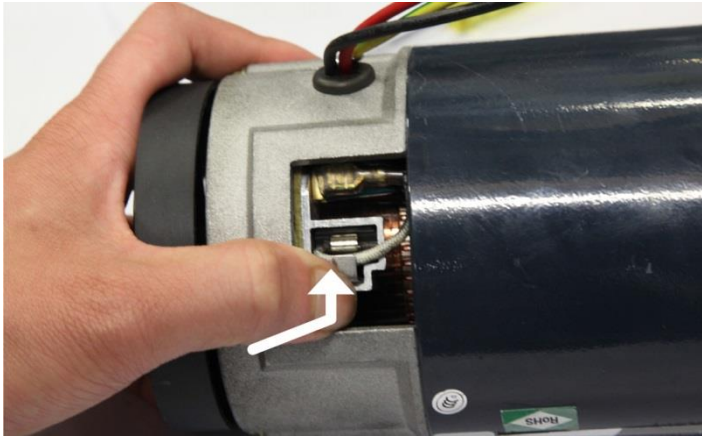

4b. Some treadmill motors may use a push clip instead. In this case, gently push the clip inwards and then up to release it from its latch.

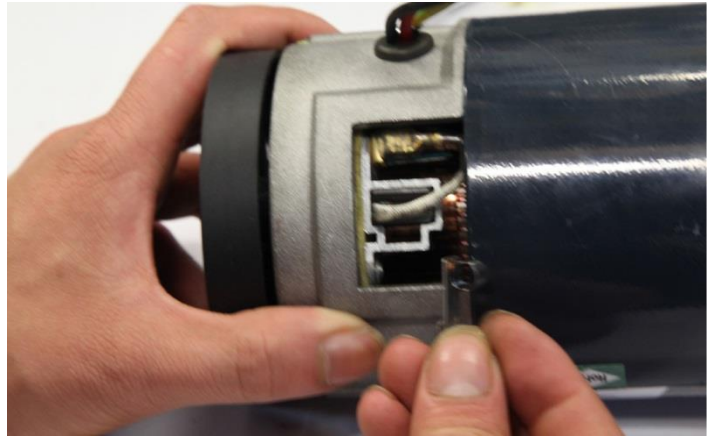

4c. Remove the clip, noting the direction in which it was originally placed, and put it safely aside.

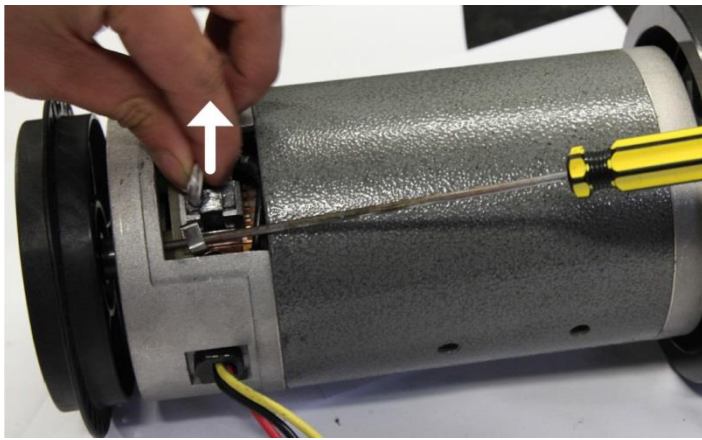

5. Slide the motor brush out from its slot. If the brush is shorter than 2cm on the longest side, you will need to replace both brushes.

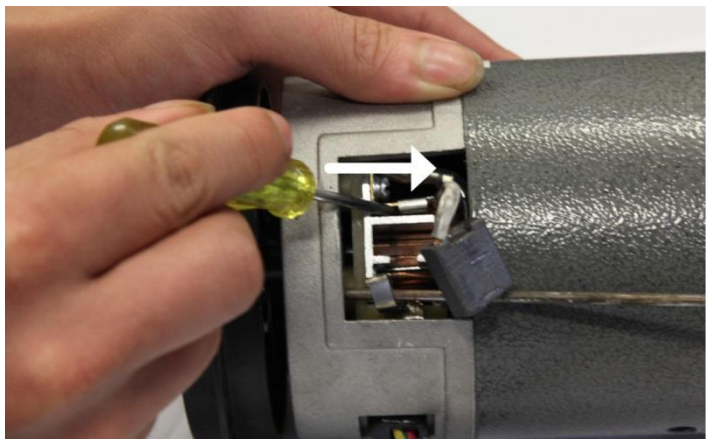

6. Slide the motor brush lead off the terminal using a another small screwdriver or needle-nosed pliers.

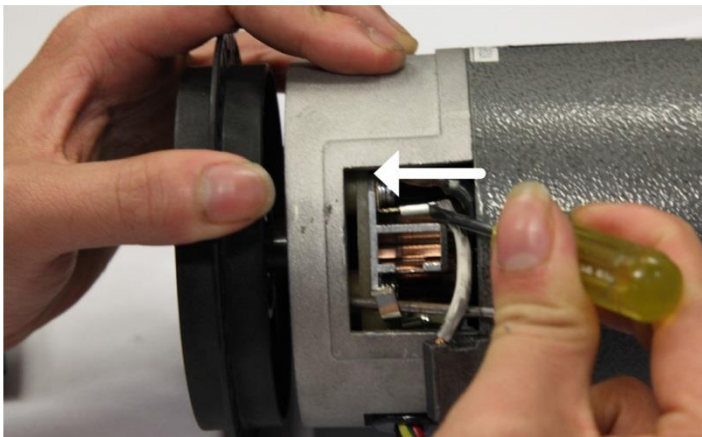

7. Plug the new motor brush lead into the terminal.

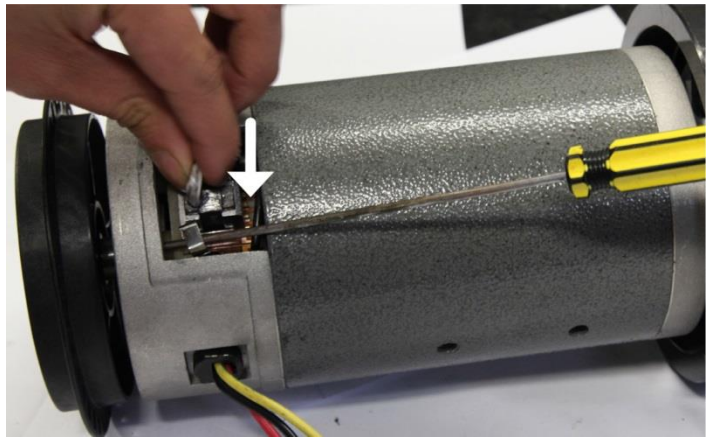

8. Slide the new motor brush into the slot.

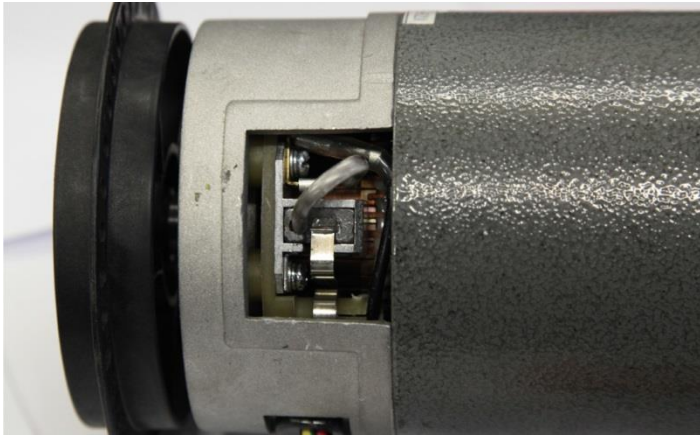

9a. Release the clip back into its position.

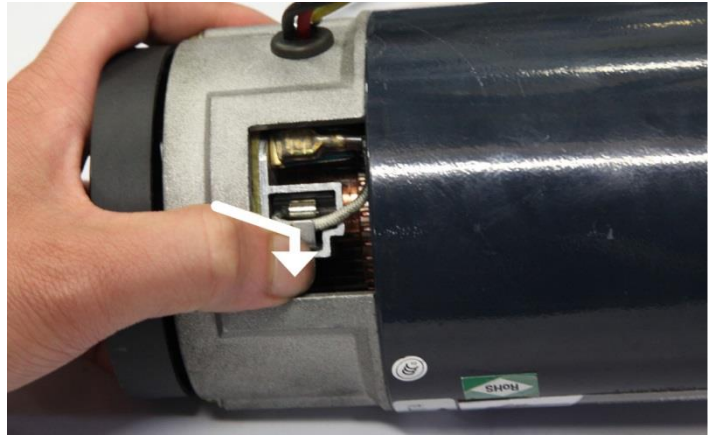

9b. If your motor uses a push clip, replace the push clip by pushing it inwards and then down so that it engages the catch.

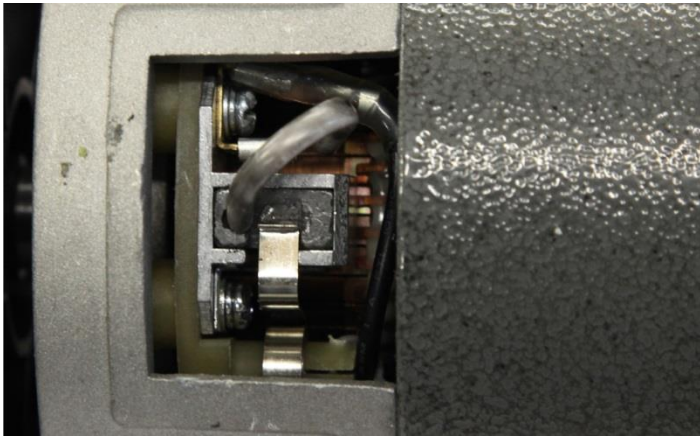

10. Check that the motor brush is held firmly in place by the clip, and that the lead is plugged securely onto the terminal.

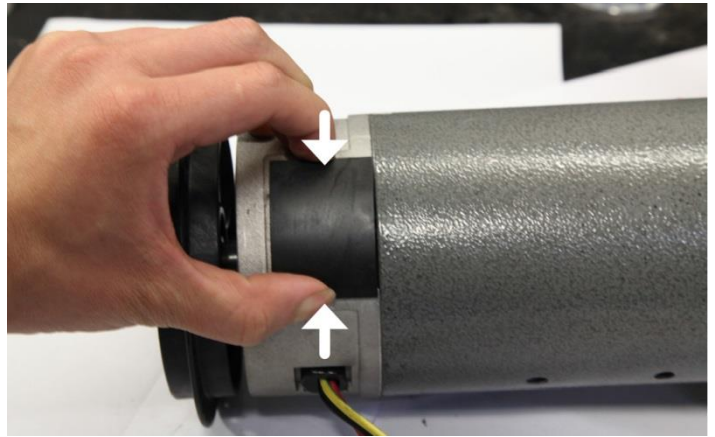

11. Replace the motor cover. Repeat steps 1-15 for the second brush located on the opposing side of the motor.

12. You have now successfully replaced the motor brushes. We also recommend that you remove any dirt and dust from your treadmill motor fan using a vacuum cleaner before replacing the cover.

9. EXPLODED DIAGRAM

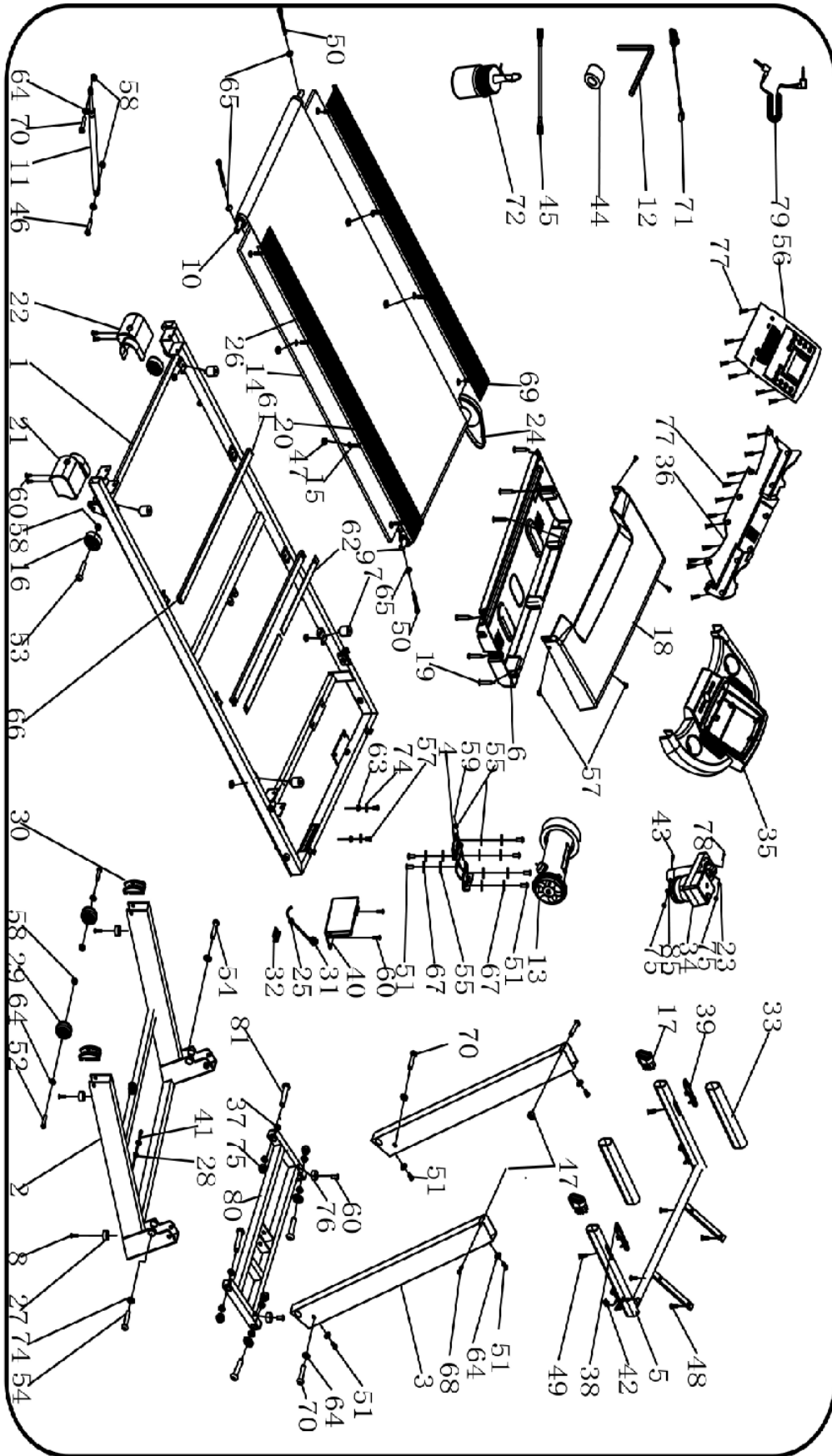

10. PARTS LIST

NO	DESCRIPTION	SPECS.	QTY	NO.	DESCRIPTION	SPECS.	QTY
1	Main Frame		1	45	Brown Single Line		1
2	Base Frame		1	46	Bolt	M8*25	1
3	Upright Frame		2	47	Lock Nut	M6	6
4	Motor Bracket		1	48	Screw	ST4.2*20	8
5	Computer Bracket		1	49	Screw	ST4.2*45	2
6	Motor bottom cover		1	50	Bolt	M6*65	3
7	Cushion		4	51	Bolt	M8*16	10
8	Screw	ST4.2*25	4	52	Bolt	M8*45	2
9	Front Roller		1	53	Bolt	M8*40	2
10	Rear Roller		1	54	Bolt	M10*55	2
11	Cylinder		1	55	Flat Washer C	8	7
12	5#Allen wrench	5mm	1	56	Panel		1
13	DC Motor		1	57	Bolt	M5*8	5
14	Running Board		1	58	Lock Nut	M8	10
15	Bolt	M6*35	4	59	Bolt	M8*25	1
16	wheel		2	60	Screw	ST4.2*19	6
17	Inclined tube plug		2	61	Running Board Strengthen tube		2
18	Motor up cover		1	62	Strengthen tube cushion	275*20*3	4
19	Screw		7	63	Lock washer	5	1
20	Side rails		2	64	Lock washer	8	10
21	Right back end cover		1	65	Lock washer	6	3
22	Left back end cover		1	66	Nylon isolation mat	φ23*φ10.5*2	4
23	Lock washer	10	4	67	Spring washer	8	6
24	Motor belt		1	68	Bolt	M6*37	2
25	Power Socket		1	69	Bolt	M8*25	4
26	Running belt		1	70	Bolt	M8*42	3
27	Foot pad		4	71	Safety key		1
28	Ring wire protector B		2	72	Oil Bottle		1
29	Moving Wheel		2	73	Spring washer	5	1
30	Moving wheel cover		2	74	Lock washer	10	2
31	Standard power wire		1	75	Lock Nut	M10	6
32	Power switch		1	76	Cushion		2
33	Foam		2	77	Screw	ST4.2*13	17
34	Incline Motor		1	78	Bolt	M10*42	1
35	Computer cover		1	79	MP3 Wire	Optional	1
36	Computer seal cover		1	80	Incline frame		1
37	Ring wire protector A		8	81	Bolt	M10*45	4
38	Hand pulse with Speed+/-		1				
39	Hand pulse with incline+/-		1				
40	Control Board		1				
41	Computer bottom wire		1				
42	Computer up wire		1				
43	Bolt	M10*55	1				
44	Magnetic ring		1				

11. TROUBLE SHOOTING GUIDE

CODE	SOLUTION
E01	Reason: signal failure within the connection between computer and controller
	Solution: A. Check that the wires connecting the computer and controller are not damaged and are connected well. B. Replace the IC of controller or computer.
E02	Reason: Burst Clash
	Solution: A. Check the power is right, if not, use correct power to test. B. Check if the bottom control was burnt out, change a good one and reconnect the motor wire.
E03	Reason: Speed feedback is not detected by controller when motor is running
	Solution: A. Check if the motor rotates when the machine starts before displaying E03. If so, conduct the following checks. 1. Check that the speed sensor is attached well. 2. Check that the speed sensor wires are not damaged 3. Check that the interface between light sensor and 4 white pin on the controller is connected well 4. Check if the peripheral area of the four white pin is damaged 5. Consider replacing controller and IC B. If the motor does not running when you start the machine and E03 shows, check if the motor is stuck. If the problem persists, consider replacing the motor.
E05	Reason: The voltage is over the protection value when the motor is running.
	Solution: A. Check if the motor is in good condition, and if there anything stuck in running belt or roller so as to unnaturally increase the resistance of for the motor. B. Replace the controller
E06	Reason: Treadmill not starting after pressing the Start button.
	Solution: A. Check the magnetic parts of the safety key are in contact with the treadmill

	<p>B. Open the computer, check safety switch line plug and check for safety switch board damage and that the plug is in position.</p> <p>C. Check the control board to see if it is burnt out.</p>
Unable to control speed	Solution: Refer to E03
No Power	Solution: <p>A. Check the fuse</p> <p>B. Check that the power plug terminal is in good contact with the controller.</p>
Abnormal motor torque	Solution: <p>A. Check whether the motor condition and motor belt tension. Replace motor if necessary</p> <p>B. If motor is in good condition, replace control board or IC.</p>
Motor burnt out	Solution: <p>A. Check if the control is also burnt.</p> <p>B. Replace the motor</p> <p>C. Replace the controller</p>
Incline cannot be controlled	Solution: <p>A. Check incline motor power wire and 3pin line connection with controller</p> <ol style="list-style-type: none"> 1. Remove the computer wire installed on the controller (safety lock), turn on the power, press down on the small key on the right corner of controller 2 seconds 2. The incline motor will initiate an automatic signal detection procedure. The motor will ascend to the highest level then descend to the lowest level 3. When the motor reaches the lowest level, after 3 seconds, the procedure will be over. 4. After the procedure, connect the computer wire (or the safety key). Operate the computer function and test the incline function <p>B. Change the controller</p>
Power interruption	Solution: <p>A. Check if the power wire is connected well</p> <p>B. Check wire – controller connection</p>
No display appearing on LCD	Solution: <p>A. Check if the voltage is correct</p> <p>B. Check that the electronic power supply is 8V</p> <p>C. Change the controller</p> <p>D. Change the computer</p>
LCD screen flashing	Solution: <p>A. Check if the voltage is correct</p> <p>B. Check that the electronic power supply is 8V</p> <p>C. Change the controller</p> <p>D. Change the computer</p>

LCD display faulty	Solution: <ol style="list-style-type: none"> 1. Turn off power supply 2. Repower the motor, observe if normal or not 3. If not, remove computer and fixed PCB. Check for damage 4. If no damage clean the PCB gold finger position and retest
LCD displaying but with dysfunction	Solution: <ol style="list-style-type: none"> A. Turn off power supply and repower the motor B. Change the computer.
backlight is not bright	Solution: <ol style="list-style-type: none"> A. Turn off the power supply and repower the motor. B. Start the computer, check if all wires are connected well. Check for backlight damage C. Change the computer
A button is not functioning	Solution: <ol style="list-style-type: none"> A. If only one key is not working, open the computer and check the button for damage B. Replace the computer
	<ol style="list-style-type: none"> A. If most keys do not work, restart the treadmill B. Replace the computer
Pulse function is unresponsive	Solution: <ol style="list-style-type: none"> A. Wash your hands, test again B. Check for damage to the pulse sensor cables as well as the connection terminal C. Change PCB or computer

12. WARRANTY

AUSTRALIAN CONSUMER LAW

Many of our products come with a guarantee or warranty from the manufacturer. In addition, they come with guarantees that cannot be excluded under the Australian Consumer Law. You are entitled to a replacement or refund for a major failure and compensation for any other reasonably foreseeable loss or damage.

You are entitled to have the goods repaired or replaced if the goods fail to be of acceptable quality and the failure does not amount to a major failure. Full details of your consumer rights may be found at www.consumerlaw.gov.au

Please visit our website to view our full warranty terms and conditions:

<http://www.lifespanfitness.com.au/warranty-repairs>

Warranty and Support:

Please email us at support@lifespanfitness.com.au for all warranty or support issues.

For all warranty or support related enquiries an email must be sent before contacting us via any other means.

Hand Pulse Technology

Our products come equipped with hand pulse sensors which are used to pick up tiny EKG/ECG signals that run through the body when your heart beats. These electrical EKG/ECG signals are very small and that they must be amplified 1000 times to make the signal useful for the display to display your pulse.

To ensure proper operation:

- The user must maintain good, consistent contact on all four sensors
- The users skin cannot be too dry or too wet

Other factors that could affect the reading:

- Change of grip on the sensors (during slow pace walking and up to running)
- Tightening of hand muscles will produce small electrical signals
- Static electricity charges from the air or from walking on the treadmill

EKG/ECG Sensors may filter through actual EKG/ECG signals and “Noise” factors that may affect the reading. This will cause the pulse reading to be delayed and will take longer to update the display as the heart rate changes. Too much noise will create an incorrect reading. Medical conditions or having no electrical signal in the hands are other factors that may affect pulse readings as well.

These are limitations of hand pulse technology and even the most expensive systems (which can cost upwards of \$3,000) used in hospitals have the same problems. The difference is that a patient in a hospital is not running on a treadmill. Hand pulse technology works well on stationary exercise machines like bikes and even elliptical cross trainers but are not perfect on a treadmill. We offer treadmills with a wireless heart rate receiver which may be a more accurate option.

To test if your hand pulse sensors are working up to specification, hold them while standing on the side step rails, not walking, and see if the reading is more in line with what you would expect. This will eliminate the movement and static electricity factors. If your hands are dry, then wet them slightly (saliva works as a great conductor if this doesn't bother you).

For more information, please contact our Lifespan Technical Support Department

www.lifespanfitness.com.au

support@lifespanfitness.com.au