



CONTROL OWNER'S MANUAL



Product may vary slightly from the item pictured due to model upgrades

Read all instructions carefully before using this product. Retain this owner's manual for future reference.

TABLE OF CONTENTS

1.	IMPORTANT SAFETY INSTRUCTIONS_____	3
2.	IMPORTANT ELECTRICAL INFORMATION_____	4
3.	IMPORTANT OPERATING INSTRUCTIONS_____	5
4.	BREIF DESCRIPTION_____	6
5.	ASSEMBLY INSTRUCTIONS_____	7
6.	GROUNDING METHODS_____	10
7.	OPERATION GUIDE_____	11
8.	EXERCISE GUIDE_____	15
9.	MAINTENANCE INSTRUCTIONS_____	17
10.	TROUBLE SHOOTING GUIDE_____	21
11.	WARRANTY REGISTRATION _____	22
12.	PROGRAM LIST_____	23

1. IMPORTANT SAFETY INSTRUCTIONS

WARNING - Read all instructions before using this treadmill.

It is important your treadmill receives regular maintenance to prolong its useful life. Failing to regularly maintain your treadmill may void your warranty.

Danger – To reduce the risk of electric shock disconnect your treadmill from the electrical outlet prior to cleaning and/or service work.

DO NOT USE AN EXTENSION CORD: DO NOT ATTEMPT TO DISABLE THE GROUNDED PLUG BY USING IMPROPER ADAPTERS OR IN ANY WAY MODIFY THE CORD SET.

- Install the treadmill on a flat level surface with access to a 220-240 volt (50/60Hz), grounded outlet.
- Do not operate treadmill on deeply padded, plush or shag carpet. Damage to both carpet and treadmill may result.
- Do not block the rear of the treadmill. Provide a minimum of 1 metre clearance between the rear of the treadmill and any fixed object.
- Place your unit on a solid, level surface when in use
- Never allow children on or near the treadmill.
- When running, make sure the plastic clip is fastened on your clothing. It is for your safety, should you fall or move too far back on the treadmill.
- Keep hands away from all moving parts.
- Never operate the treadmill if it has a damaged cord or plug.
- Keep the cord away from heated surfaces.
- Do not operate where aerosol spray products are being used or where oxygen is being administered. Sparks from the motor may ignite a highly gaseous environment.
- Never drop or insert any object into any openings.
- The treadmill is intended for in-home use only and not suitable for long time running.

- To disconnect, turn all controls to the off position, remove the safety key, and then remove the plug from the outlet.
- The pulse sensors are not medical devices. Various factors, including the user's movement, may affect the accuracy of heart rate readings. The pulse sensors are intended only as exercise aids in determining heart rate trends in general.
- Use the handrails provided; they are for your safety.
- Wear proper shoes. High heels, dress shoes, sandals or bare feet are not suitable for use on your treadmill. Quality athletic shoes are recommended to avoid leg fatigue.
- Allowed temperature: 5 to 40 degrees.

Remove the safety key after use to prevent unauthorized treadmill operation.

2. IMPORTANT ELECTRICAL INFORMATION

WARNING!

- NEVER use a ground fault circuit interrupt (GFCI) wall outlet with this treadmill. Route the power cord away from any moving part of the treadmill including the elevation mechanism and transport wheels.
- NEVER remove any cover without first disconnecting AC power.
- NEVER expose this treadmill to rain or moisture. This treadmill is not designed for use outdoors, near a pool, or in any other high humidity environment.

3. IMPORTANT OPERATING INSTRUCTIONS

- Be sure to read the entire manual before operating your machine.
- Understand that changes in speed and incline do not occur immediately. Set your desired speed on the computer console and release the adjustment key. The computer will obey the command gradually.
- Use caution while participating in other activities while walking on your treadmill, such as watching television, reading, etc. These distractions may cause you to lose balance or stray from walking in the centre of the belt; which may result in serious injury.
- In order to prevent losing balance and suffering unexpected injury, **NEVER** mount or dismount the treadmill while the belt is moving. This unit starts with at a very low speed. Simply standing on the belt during slow acceleration is proper after you have learned to operate this machine.
- Always hold on to handrail while making control changes.
- A safety key is provided with this machine. Remove the safety key will stop the walking belt immediately; the treadmill will shut off automatically. Inserting the safety key will reset the display.
- Do not use excessive pressure on console control keys. They are precision set to function properly with little finger pressure.

4. BREIF DESCRIPTION

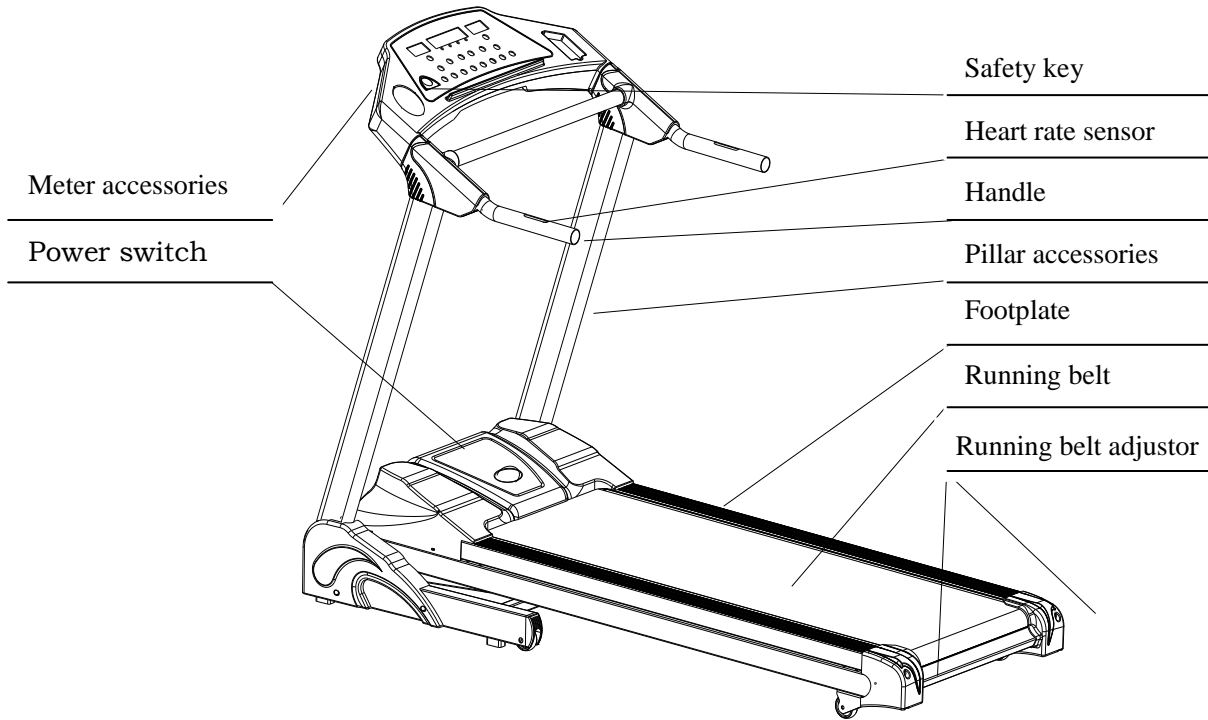

5. ASSEMBLY INSTRUCTIONS

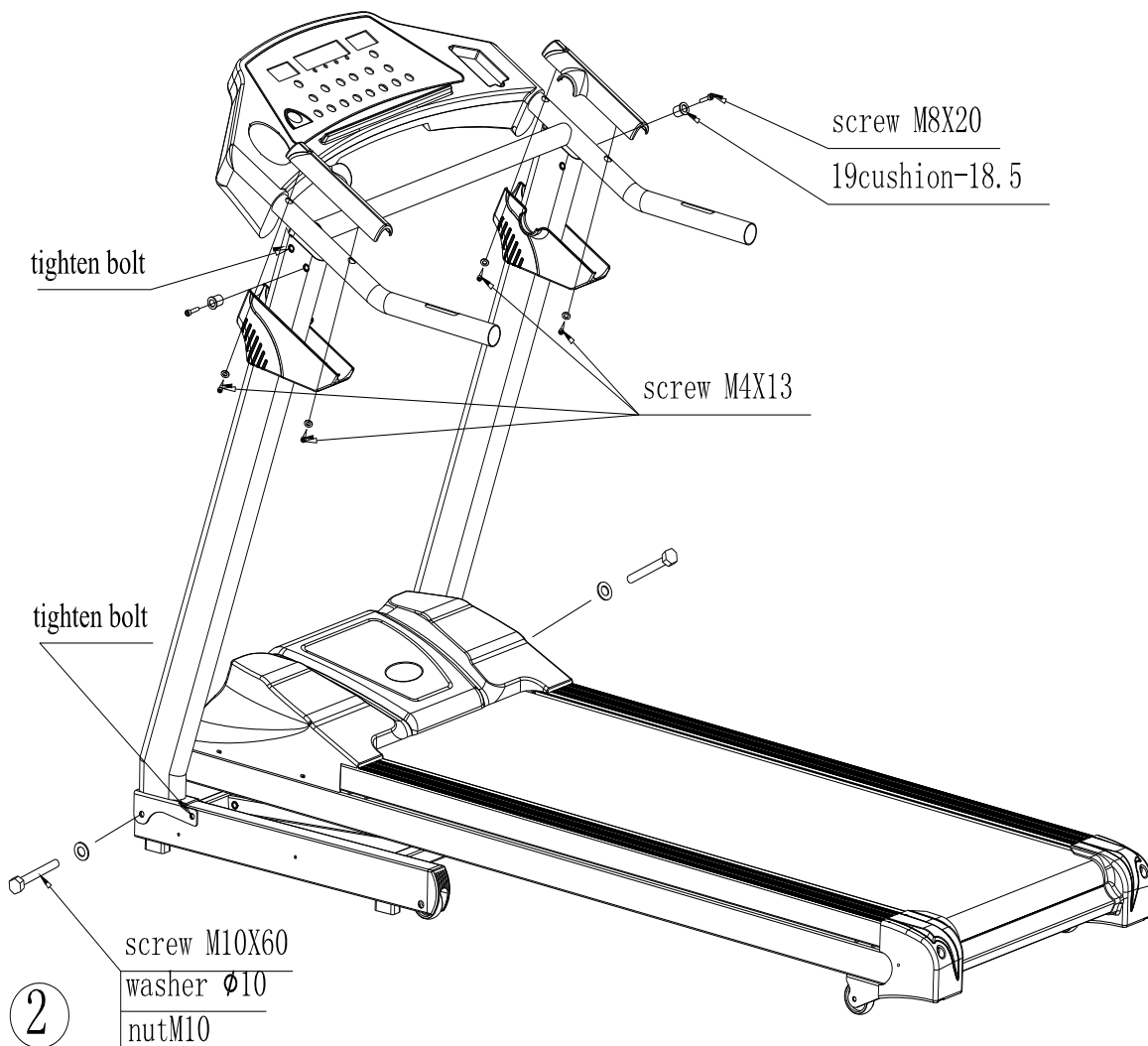
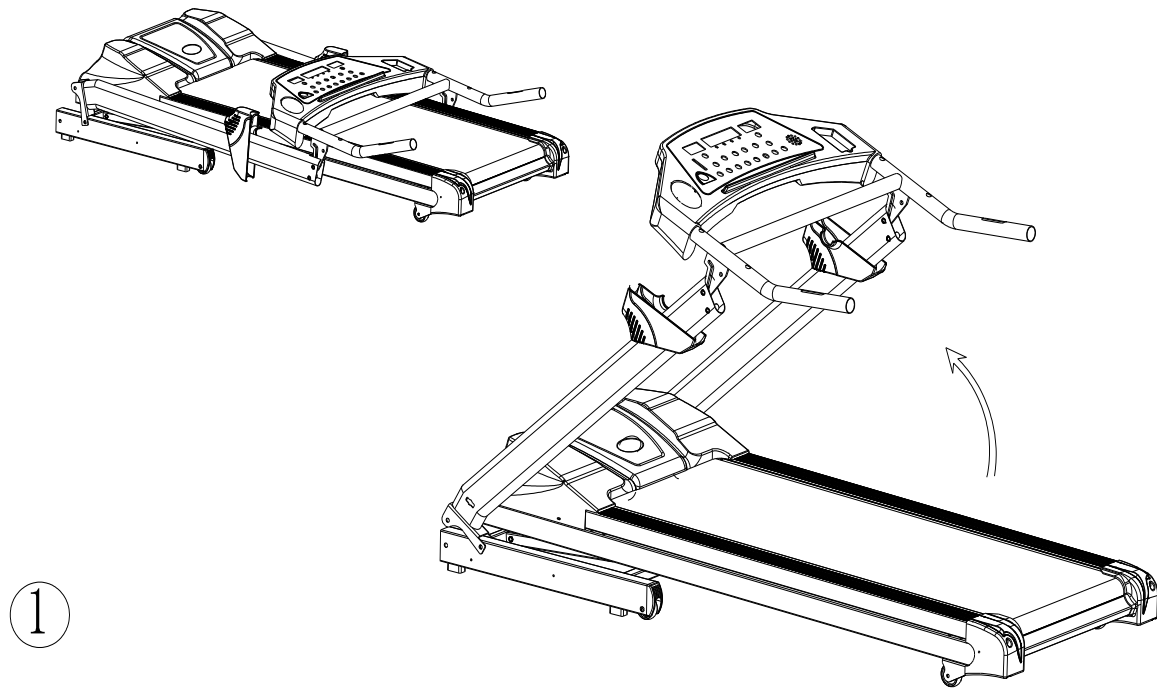

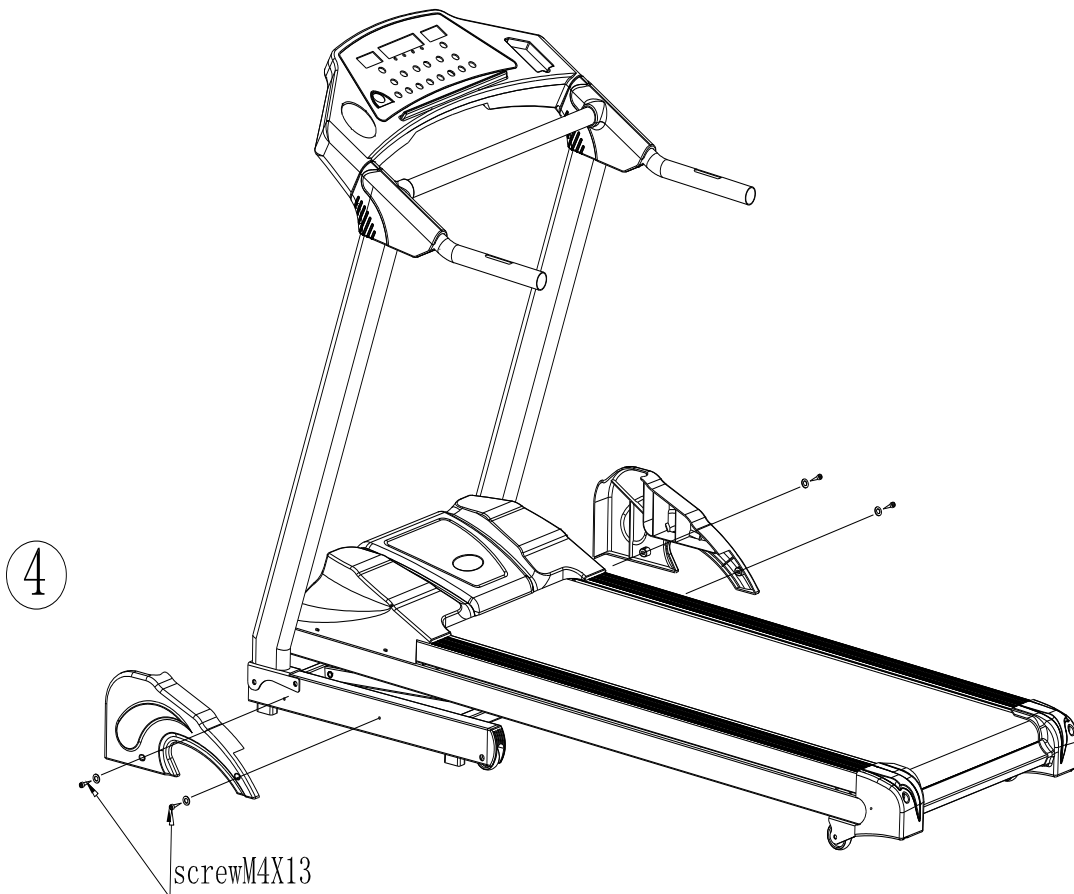
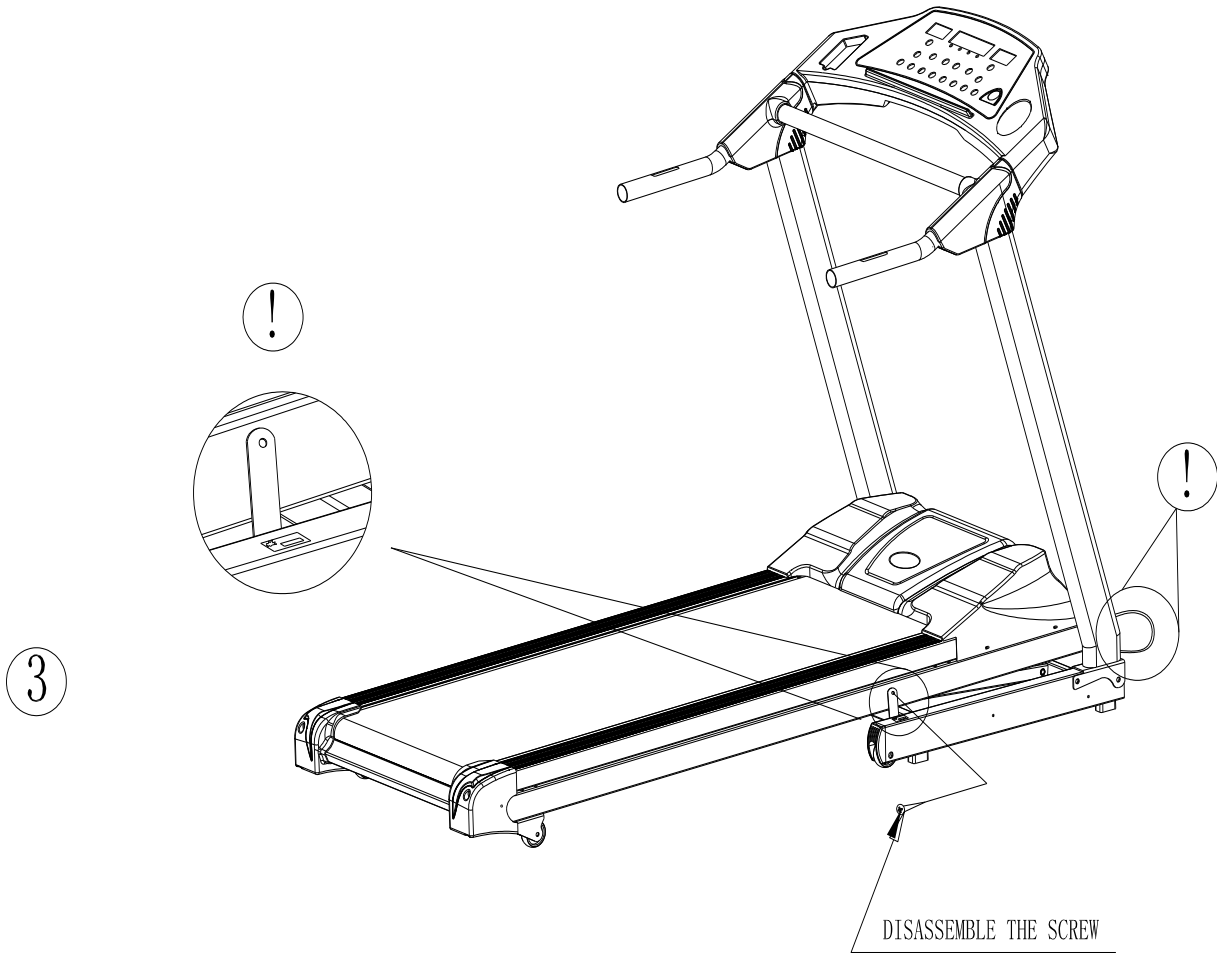

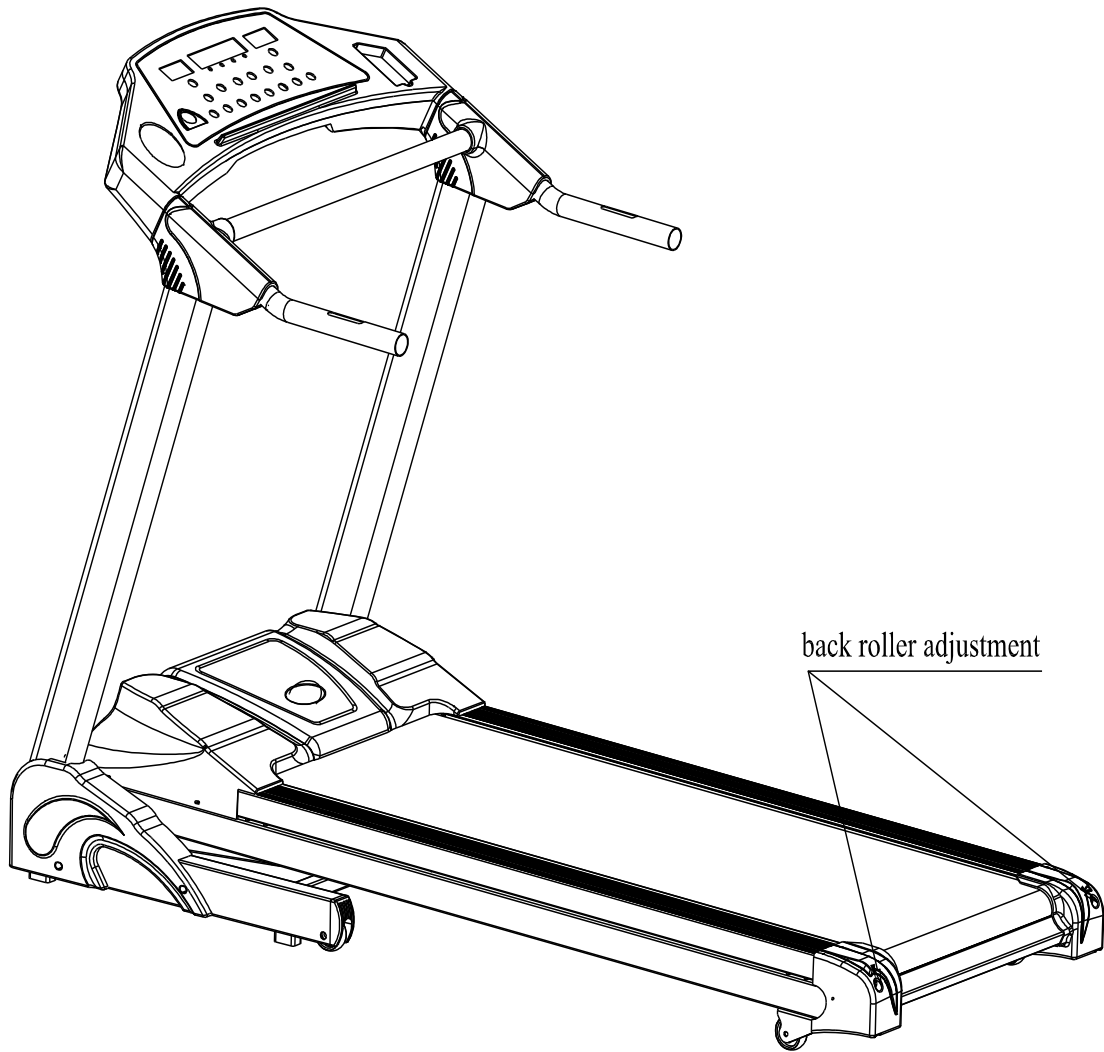

See Page 20 for more detail

5

6. GROUNDING METHODS

This product must be grounded. In the event of malfunction or breakdown, grounding reduces the risk of electric shock. This product is equipped with a cord with an equipment-grounding conductor and a grounding plug. The plug must be plugged into an appropriate outlet that is properly installed and grounded in accordance with all local codes and ordinances.

DANGER

Improper connection of the equipment-grounding conductor can result in risk of electric shock.

Check with a qualified electrician or serviceman if you are in doubt as to whether the product is properly grounded.

Do not modify the plug provided with the product – if it will not fit the outlet; have a proper outlet installed by a qualified electrician.

This product is for use on a nominal 240-volt circuit and has a grounding plug that looks like the plug illustrated in sketch A in following figure. Ensure the product is connected to an outlet having the same configuration as the plug. No adapter should be used with this product.

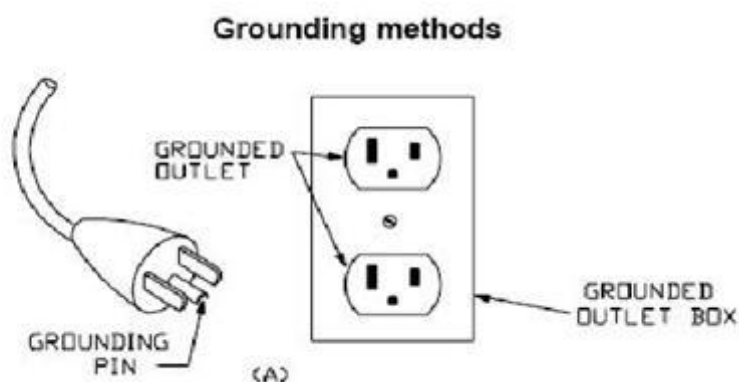

7. OPERATION GUIDE

1. Overview

- (16) Time, distance, calorie, heart rate windows
- (1) On
- (15) Incline window
- (2) Clear/set
- (3) Mode
- (4) Stop
- (12) Speed window

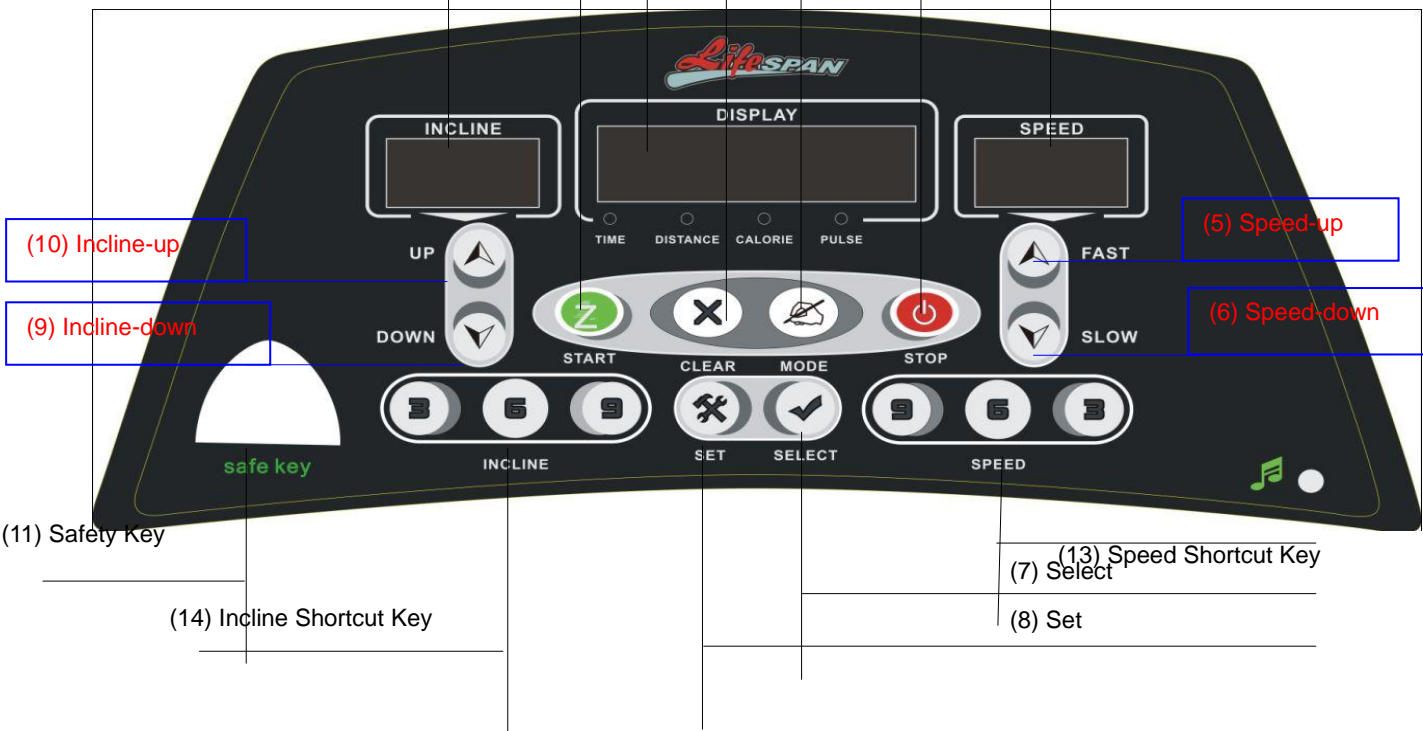

(10) Incline-up

(9) Incline-down

(5) Speed-up

(6) Speed-down

(11) Safety Key

(14) Incline Shortcut Key

(13) Speed Shortcut Key

(7) Select

(8) Set

2. Panel Keys and Functions

1. *“on”*

Begins workout, when the power is on and safety key correctly placed on the computer, press this button to start the treadmill.

2. *“clear/set”*

Press button to reset machine to default values.

3. *“profile”*

Press this key to enter own programs mode, you have 3 own programs, C1~C3, P1-P99 are fixed programs.

4. *“off”*

Press this key to stop the machine from running

5. *“speed up”*

Increase speed.

6. *“speed down”*

Decrease speed.

7. *“select”*

Press this key to cycle through displaying time, distance and calories.

8. *“set”*

Sets a countdown time, a countdown distance or countdown calories

9. *“incline up”*

Increase incline.

10. *“incline down”*

Decrease incline.

11. *“safety key”*

Removing this key stop the machine immediately

12. *Speed Window*

Displays current speed

13. *“speed short cut key”*

Directly sets speed value.

14. *“incline short cut key”*

Directly sets incline value.

15. *Incline window*

Displays current window

16. *Time, distance, calorie and heart rate window*

Shows time, distance, calories and heart rate

3. Unload Operating

- 1) Insert power plug into the socket with earth wire, turn the switch to “1” position which is on the frame.
- 2) Put the safe key in the right position, when circuit is on, press “on/off”, keep it running in unload condition. Do not run on the belt at this time .Test the condition of running belt (testing from low speed to high ones), after testing, press “on/off”.
- 3) If everything is ok, press start and begin your workout.

4. Meter Operating Instructions

- 1) Insert power plug into the socket with earth wire, turn the switch to “1” position which is on the frame. Place the safe key to the appointed position. After a few seconds, panel will show that the machine is ready.
- 2) Nip another end of safe key to your clothes, and stand on the footplate on both sides.
- 3) Press “on/off” key, running belt moves at the lowest speed (1.0km/h). Speed windows will display your running speed.
- 4) Start to run.
- 5) Press speed key or incline key to adjust speed and incline, speed window and incline window will display your speed and incline.
- 6) To end your exercise in a safe way, please first press “on/off” key to close the treadmill. Please leave the running belt until it stops slowly. Turn off the power.

5. Heart Rate:

When holding the hand pulse with two hands, the pulse window will show your heart rate after 5 seconds. To increase accuracy please check heart rate with the machine stopped and after keeping your hands on the sensors for more than 30 seconds.

The heart rate data is for reference purposes ONLY.

6. Folding and Unfolding:

Folding:

Firstly lift and fold the back part of the frame board by hand till you hear a light “click” sound, which means the folding system has been locked.

Unfolding:

Put the folded treadmill in a capacious position when you want to run. Then pull the adjustment parts by hand to keep it is unlocked. Press the back part by your hands down to about 10%, release it, then treadmill will descend automatically.

8. EXERCISE GUIDE

PLEASE NOTE: Before beginning any exercise program, consult your physician. This is important especially if you are over the age of 45 or individuals with pre-existing health problems.

The pulse sensors are not medical devices. Various factors, including the user's movement, may affect the accuracy of heart rate readings. The pulse sensors are intended only as an exercise aid in determining heart rate trends in general.

Exercising is great way to control your weight, improving your fitness and reduce the effect of aging and stress. The key to success is to make exercise a regular and enjoyable part of your everyday life.

The condition of your heart and lungs and how efficient they are in delivering oxygen via your blood to your muscles is an important factor to your fitness. Your muscles use this oxygen to provide enough energy for daily activity. This is called aerobic activity. When you are fit, your heart will not have to work so hard. It will pump a lot fewer times per minute, reducing the wear and tear of your heart.

So as you can see, the fitter you are, the healthier and greater you will feel.

Warm-up

Start each workout with 5 to 10 minutes of stretching and some light exercises. A proper warm-up increases your body temperature, heart rate and circulation in preparation for exercise. Ease into your exercise.

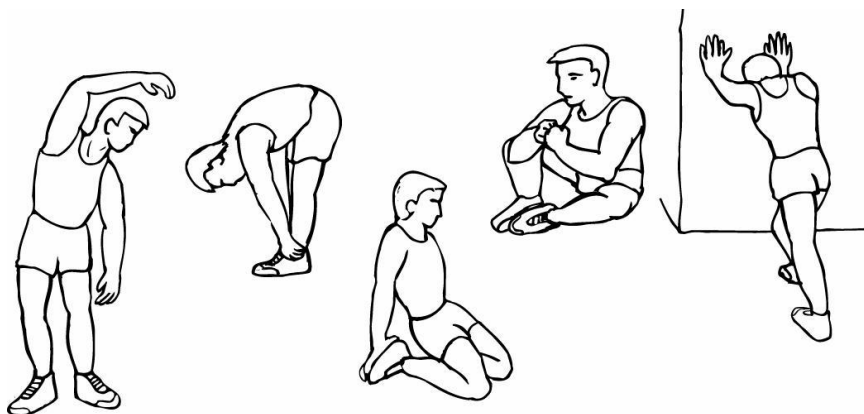

Training Zone Exercise

After warming up, increase the intensity to your desired exercise program. Be sure to maintain your intensity for maximum performance. Breathe regularly and deeply as you exercise-never hold your breath.

Cool Down

Finish each workout with a light jog or walk for at least 1 minute. Then complete 5 to 10 minutes of stretching to cool down. This will increase the flexibility of your muscles and will help prevent post-exercise problems.

Workout Guidelines

TARGET ZONE

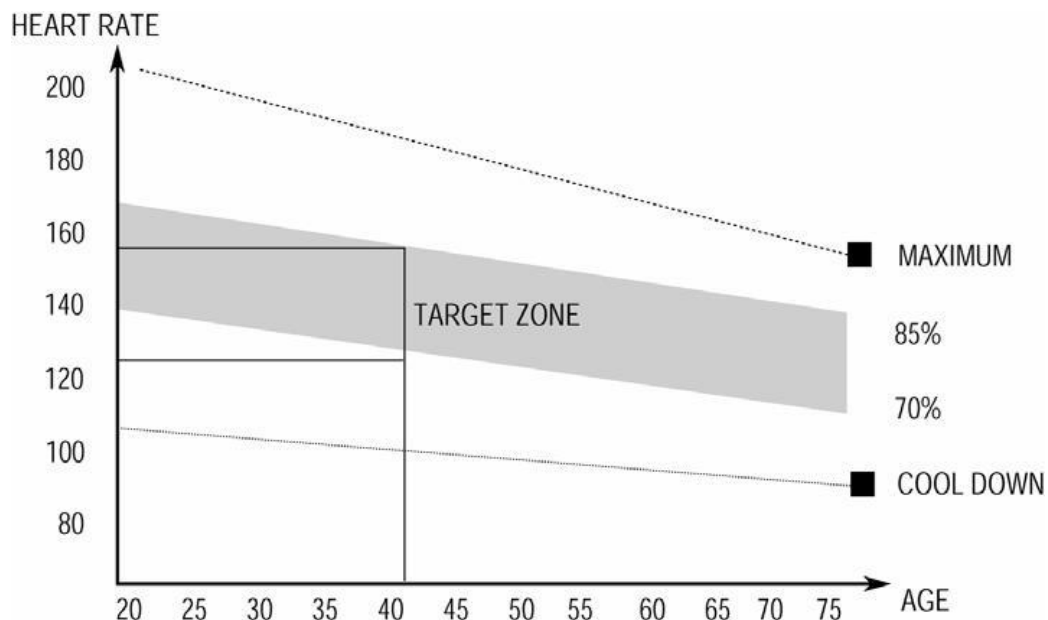

THIS IS HOW YOUR PULSE SHOULD BEHAVE DURING GENERAL FITNESS EXERCISE.

REMEMBER TO WARM UP AND COOL DOWN FOR A FEW MINUTES.

The most important factor here is the amount of effort you put in. The harder and longer you work, the more calories you will burn. Effectively this is the same as if you were training to improve your fitness, the difference is the goal.

9. MAINTENANCE INSTRUCTIONS

Reasonable cleaning/lubricating should be made to extend the life time of this unit. Performance is maximized when the belt and mat are kept as clean as possible.

WARNING: THE MAT/DECK FRICTION MAY PLAY A MAJOR ROLE IN THE FUNCTION AND LIFE OF YOUR TREADMILL AND THAT IS WHY WE RECOMMEND YOU CONSTANTLY LUBRICATE THIS FRICTION POINT TO PROLONG THE USEFUL LIFE OF YOUR TREADMILL. FAILING TO DO THIS MAY VOID YOUR WARRANTY.

WARNING: UNPLUG POWER CORD BEFORE MAINTENANCE

WARNING: STOP TREADMILL BEFORE FOLDING

1. General Cleaning

- Use a soft, damp cloth to wipe the edge of the belt and the area between the belt edge and frame. A mild soap and water solution along with a nylon scrub brush will clean the top of the textured belt. This task should be done once a month. Allow to dry before using.
- On a monthly basis, vacuum underneath your treadmill to prevent dust build up. Once a year, you should remove the black motor shield and vacuum out dirt that may accumulate.

2. General Care

- Check parts for wear before use.
- Pay particular attention to the fixing knobs and make sure they are tight.
- Always replace the mat if worn and any other defective parts.

- If in doubt do not use the treadmill and contact our helpline.

TAKE CARE TO PROTECT CARPETS AND FLOOR in case of leakages. This product is a machine that contains moving parts which have been greased / lubricated and could leak.

3. Belt/Deck/Roller Lubrication

The mat/deck friction may play a major role in the function and life of your treadmill and that is why we recommend you constantly lubricate this friction point to prolong the useful life of your treadmill. Lubrication is provided with this unit. You should apply the enclosed lubrication after approximately the first 50 hours of operation. We recommend lubrication of the deck according to the following timetable:

- Light use (less than 3 hours per week) every 6 months
- Medium use (3-5 hours a week) every 3 months
- Heavy use (more than 5 hours per week) every 6-8 weeks

See below procedures for lubricating:

1. Use a soft, dry cloth to wipe the area between the belt and deck.
2. Spread lubricant onto the inside surface of belt and deck evenly (make sure the machine is turned off and power is disconnected).
3. Periodically lubricate the front and rear rollers to keep them at their peak performance. If the treadmill belt/deck/roller is kept reasonably clean it is possible to expect over 1200 hours before relubricating is necessary.

4. How to check the running mat for proper lubrication:

1. Disconnect the main power supply.
2. Fold the treadmill up into the storage position.
3. Feel the underside surface of the running mat.

If the surface is slick when touched, then no further lubrication is needed.

If the surface is dry to the touch, apply a suitable silicone lubricant.

We recommend that you use a silicone based spray to lubricate your Lifespan treadmill. This can be purchased from your local sports retailer or hardware store.

5. Belt Tension Adjustment

It is very important for joggers and runners in order to provide a smooth, steady running surface. Adjustment must be made from the right and left rear roller in order to adjust tension with the Allen Key provided in the parts package. The adjustment bolt is located at the end of the rails as noted in the diagram below:

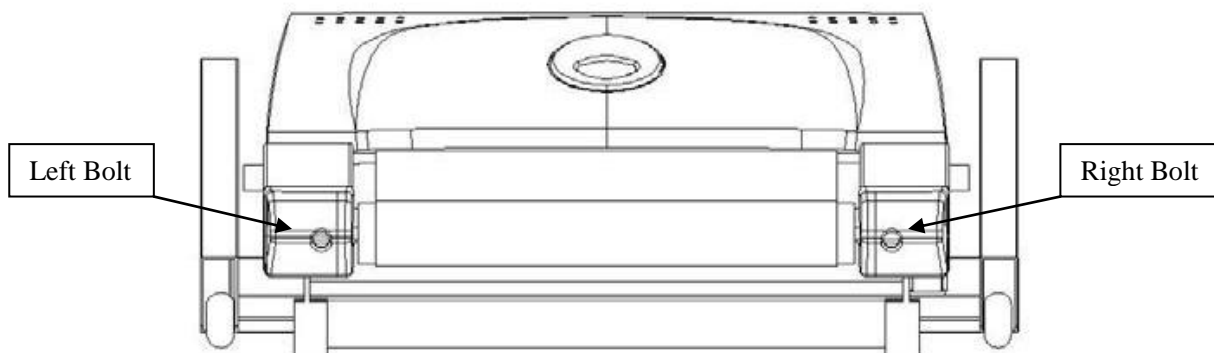

Note: Adjustment is through small hold of end cap.

Tighten the rear roller only enough to prevent slippage at the front roller. Turn both the right and left bolt clockwise one full turn and inspect for proper tension. When an adjustment is made to the belt tension, you must also make a tracking adjustment to compensate for the change in belt tension.

DO NOT OVER TIGHTEN - Over tightening will cause belt damage and premature bearing failure.

This may also cause reduced motor performance and excessive roller wear.

NOTE: When properly tightened, the sides of the belt can be raised approximately 2-3 inches off the board.

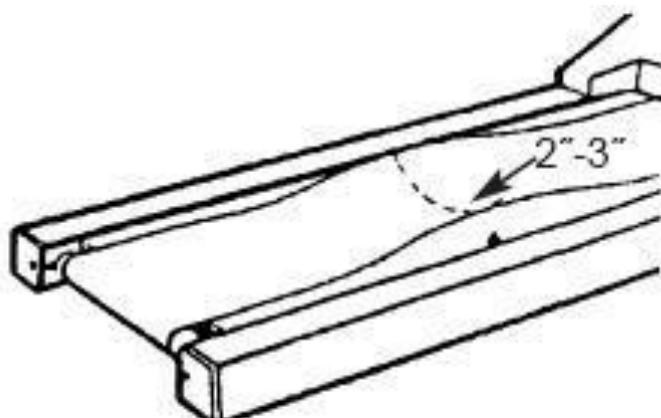

6. Belt Tracking Adjustment:

This treadmill is designed to keep the belt reasonably centred while in use. It is normal for some belts to drift near one side while the belt is running with no one on it. After a few minutes of use, the belt should have a tendency to centre itself. If during use, the belt continues to move toward one side, adjustments are necessary. The procedures are below:

1. Set speed at approximately 3.5km/h.
2. Check the side the belt shifts to.

If the belt shifts to right, tighten the right bolt and loosen the left bolt by using 6mm Allen Key, until the belt is centred itself; If belt shifts to left, tighten the left bolt and loosen the right bolt by using a 6mm Allen Key, until the belt is centred. When adjusting the belt using the 6 mm Allen Key, it is important to adjust the belt in half turn increments. Over adjusting the belt can cause damage to the mat.

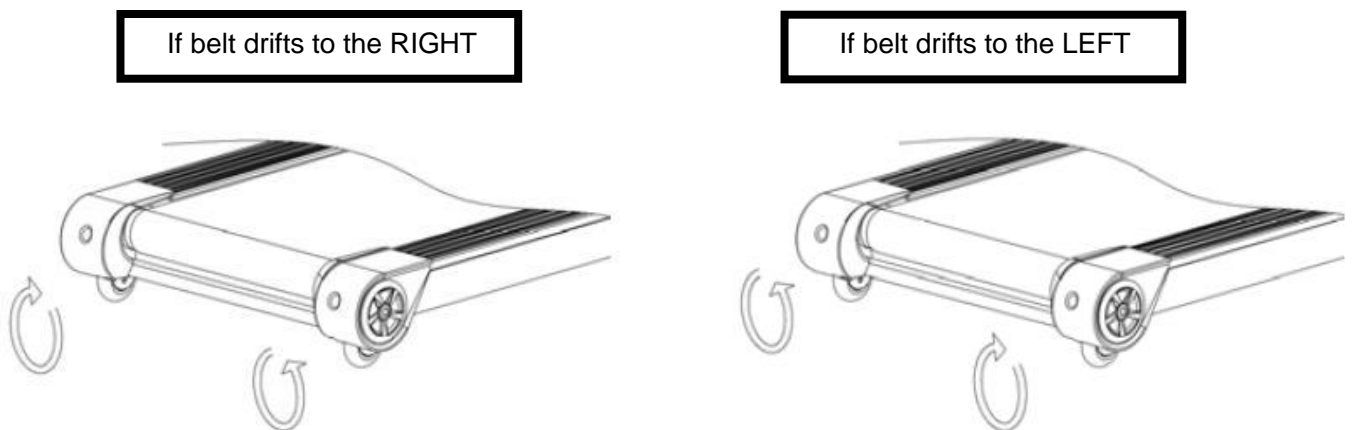

10. TROUBLE SHOOTING GUIDE

Item	Malfunction	Reasons	Solution
1	Treadmill cannot be started	The safe key isn't in the right position	Put the safe key in the right position
		The electrical switch is placed to "0"	Turn the electrical switch to "1"
		creepage switch is not right	Replace creepage switch
2	Meter will not display	The meter control line and control panel are unconnected	Pull the bolt out and open the motor cover and reconnect it
			Turn on the meter and reconnect
3	Heart rate can't be displayed	The pole of heart rate sensor is not wet enough	Wet the pole with water or liquor for hard contact lenses
		Disturbed by electromagnetism	Stay away from electromagnetism
4	Incline doesn't work	The motor wire is not well connected	Open the motor cover and reconnect it
5	Running belt runs faster or slower than what has been displayed	Unadjusted	Readjust it
6	Running belt slips	Running belt is not tight enough	Please read page 19. Adjustment steps for tightening running belt for reference
7	Running belt is deflected	The running belt is unadjusted.	Please page 20. The steps for adjusting the deflected running belt for reference

11. WARRANTY REGISTRATION

Please visit the following link to complete the product warranty form online. Please visit:

<http://www.warrantyform.lifespanfitness.com.au>

PLEASE NOTE: YOUR WARRANTY IS ONLY VALID IF YOU CAN PROVE YOU ARE THE ORIGINAL PURCHASER OF THIS ITEM (i.e. a copy of the receipt, invoice, delivery date or internet confirmation)

12. PROGRAM LIST

SECTION	1	2	3	4	5	6	7	8	9	10	11	12	13	14	15	16
P0:																
INCLINE SPEED	000,000,000,000,000,000,000,000,000,000,000,000,000,000,000,000,000,000,000,000	000,000,000,000,000,000,000,000,000,000,000,000,000,000,000,000,000,000,000,000														
P1:																
INCLINE SPEED	000,000,000,000,000,000,000,000,000,000,000,000,000,000,000,000,000,000,000,000	020,040,060,080,060,100,100,080,040,040,080,100,080,060,040,020														
P2:																
INCLINE SPEED	000,000,000,000,000,000,000,000,000,000,000,000,000,000,000,000,000,000,000,000	020,050,060,060,050,060,080,050,080,060,060,050,060,040,050,020														
P3:																
INCLINE SPEED	000,000,000,000,000,000,000,000,000,000,000,000,000,000,000,000,000,000,000,000	020,040,060,040,050,080,120,080,060,050,120,080,060,050,060,040														
P4:																
INCLINE SPEED	000,000,000,000,000,000,000,000,000,000,000,000,000,000,000,000,000,000,000,000	020,020,020,060,080,060,100,100,080,040,040,040,040,080,040,040														
P5:																
INCLINE SPEED	000,000,000,000,000,000,000,000,000,000,000,000,000,000,000,000,000,000,000,000	020,030,020,120,040,040,040,120,120,120,120,120,120,040,020,020														
P6:																
INCLINE SPEED	000,000,000,000,000,000,000,000,000,000,000,000,000,000,000,000,000,000,000,000	020,060,040,080,060,100,020,080,050,080,050,040,060,040,020,020														
P7:																
INCLINE SPEED	000,000,000,000,000,000,000,000,000,000,000,000,000,000,000,000,000,000,000,000	020,040,050,060,080,120,080,050,080,050,080,060,040,060,100,040														
P8:																
INCLINE SPEED	000,000,000,000,000,000,000,000,000,000,000,000,000,000,000,000,000,000,000,000	020,040,020,050,060,050,060,080,060,080,100,120,100,080,040,020														
P9:																
INCLINE SPEED	000,000,000,000,000,000,000,000,000,000,000,000,000,000,000,000,000,000,000,000	020,040,060,020,050,060,050,060,080,120,080,040,060,080,060,040														
P10:																
INCLINE SPEED	000,000,000,000,000,000,000,000,000,000,000,000,000,000,000,000,000,000,000,000	020,040,060,100,080,020,050,060,050,060,080,120,080,040,060,080,050,080,050														
P11:																
INCLINE SPEED	000,000,000,000,000,000,000,000,000,000,000,000,000,000,000,000,000,000,000,000	020,080,060,080,100,080,060,040,050,040,060,120,100,080,060,040														
P12:																
INCLINE SPEED	000,000,000,000,000,000,000,000,000,000,000,000,000,000,000,000,000,000,000,000	020,030,050,060,060,110,080,080,100,080,060,050,060,040,040,020														
P13:																
INCLINE SPEED	000,000,000,000,000,000,000,000,000,000,000,000,000,000,000,000,000,000,000,000	020,040,060,100,080,040,100,060,040,060,100,040,060,080,060,040														
P14:																
INCLINE SPEED	000,000,000,000,000,000,000,000,000,000,000,000,000,000,000,000,000,000,000,000	020,020,040,060,060,080,100,100,100,040,060,040,060,060,060,040,060														
P15:																
INCLINE SPEED	000,000,000,000,000,000,000,000,000,000,000,000,000,000,000,000,000,000,000,000	020,020,040,040,120,120,040,040,120,120,040,040,120,120,020,020														
P16:																
INCLINE SPEED	000,000,000,000,000,000,000,000,000,000,000,000,000,000,000,000,000,000,000,000	020,030,040,070,070,080,050,050,060,100,120,100,080,050,060,040														

P17:	INCLINE SPEED	000,000,000,000,000,000,000,000,000,000,000,000,000,000,000,000,000 020,020,040,080,100,020,040,080,080,100,050,040,070,080,060,040
P18:	INCLINE SPEED	000,000,000,000,000,000,000,000,000,000,000,000,000,000,000,000 020,030,050,080,110,120,100,080,070,060,100,100,100,080,040,020
P19:	INCLINE SPEED	000,000,000,000,000,000,000,000,000,000,000,000,000,000,000,000 020,030,060,100,090,110,100,060,120,060,110,080,060,040,060,020
P20:	INCLINE SPEED	000,000,000,000,000,000,000,000,000,000,000,000,000,000,000,000 020,050,060,080,080,080,070,060,040,060,050,040,060,080,060,040
P21:	INCLINE SPEED	000,000,000,000,000,000,000,000,000,000,000,000,000,000,000,000 020,080,060,080,100,080,060,080,080,040,060,080,080,080,060,040
P22:	INCLINE SPEED	000,000,000,000,000,000,000,000,000,000,000,000,000,000,000,000 020,070,060,070,060,070,080,070,080,070,060,070,060,070,040,020
P23:	INCLINE SPEED	000,000,000,000,000,000,000,000,000,000,000,000,000,000,000,000 020,060,060,060,060,080,120,080,060,060,060,060,080,060,040,060,060
P24:	INCLINE SPEED	000,000,000,000,000,000,000,000,000,000,000,000,000,000,000,000 020,020,020,060,060,060,100,100,100,040,040,040,040,040,040,040
P25:	INCLINE SPEED	000,000,000,000,000,000,000,000,000,000,000,000,000,000,000,000 020,040,080,090,110,110,110,100,070,070,060,060,040,020,020,030
P26:	INCLINE SPEED	000,000,000,000,000,000,000,000,000,000,000,000,000,000,000,000 020,060,040,080,040,080,060,100,060,100,080,100,080,100,060,040
P27:	INCLINE SPEED	000,000,000,000,000,000,000,000,000,000,000,000,000,000,000,000 020,040,060,080,100,020,040,060,080,060,080,040,060,080,060,080
P28:	INCLINE SPEED	000,000,000,000,000,000,000,000,000,000,000,000,000,000,000,000 020,040,060,080,070,120,070,080,060,070,100,120,070,080,070,020
P29:	INCLINE SPEED	000,000,000,000,000,000,000,000,000,000,000,000,000,000,000,000 020,030,060,100,080,040,030,060,040,060,100,040,030,030,030,030
P30:	INCLINE SPEED	000,000,000,000,000,000,000,000,000,000,000,000,000,000,000,000 020,040,060,100,040,040,100,060,040,060,100,040,060,040,060,040
P31:	INCLINE SPEED	000,000,000,000,000,000,000,000,000,000,000,000,000,000,000,000 020,040,050,050,050,050,050,050,050,020,040,060,080,100,080,060
P32:	INCLINE SPEED	000,000,000,000,000,000,000,000,000,000,000,000,000,000,000,000 020,040,050,060,060,060,080,080,080,060,060,060,060,050,040,020
P33:	INCLINE SPEED	000,000,000,000,000,000,000,000,000,000,000,000,000,000,000,000 020,050,060,050,060,080,120,080,050,080,050,080,060,040,060,040
P34:	INCLINE SPEED	000,000,000,000,000,000,000,000,000,000,000,000,000,000,000,000 020,040,030,060,080,060,100,120,100,110,080,050,040,030,040,040
P35:	INCLINE SPEED	000,000,000,000,000,000,000,000,000,000,000,000,000,000,000,000 020,050,080,080,120,120,040,040,100,100,080,040,110,110,050,020

P36:	INCLINE SPEED	000,000,000,000,000,000,000,000,000,000,000,000,000,000,000,000,000,000 020,060,040,080,040,080,060,100,060,100,080,100,080,100,080,100,060,040
P37:	INCLINE SPEED	000,000,000,000,000,000,000,000,000,000,000,000,000,000,000,000,000,000 020,030,040,060,080,100,020,100,060,080,100,020,070,060,080,100
P38:	INCLINE SPEED	000,000,000,000,000,000,000,000,000,000,000,000,000,000,000,000,000,000 020,060,080,120,120,100,080,060,080,100,120,100,080,070,040,020
P39:	INCLINE SPEED	000,000,000,000,000,000,000,000,000,000,000,000,000,000,000,000,000,000 020,030,040,050,060,070,080,090,100,090,080,070,060,050,020,020
P40:	INCLINE SPEED	000,000,000,000,000,000,000,000,000,000,000,000,000,000,000,000,000,000 020,050,050,050,080,080,090,090,110,110,070,070,060,060,050,050
P41:	INCLINE SPEED	000,000,000,000,000,000,000,000,000,000,000,000,000,000,000,000,000,000 020,040,060,080,100,080,060,040,020,040,060,080,100,080,060,040
P42:	INCLINE SPEED	000,000,000,000,000,000,000,000,000,000,000,000,000,000,000,000,000,000 030,040,050,080,090,090,110,110,110,080,080,050,050,040,040,040
P43:	INCLINE SPEED	000,000,000,000,000,000,000,000,000,000,000,000,000,000,000,000,000,000 020,020,040,040,050,050,080,080,100,100,120,080,050,040,020,020
P44:	INCLINE SPEED	000,000,000,000,000,000,000,000,000,000,000,000,000,000,000,000,000,000 020,050,070,090,100,100,110,110,120,120,100,100,090,090,040,040
P45:	INCLINE SPEED	000,000,000,000,000,000,000,000,000,000,000,000,000,000,000,000,000,000 020,030,030,030,050,050,050,080,080,080,070,070,070,050,050,020
P46:	INCLINE SPEED	000,000,000,000,000,000,000,000,000,000,000,000,000,000,000,000,000,000 020,040,080,090,120,110,110,110,100,100,080,080,050,050,040,040
P47:	INCLINE SPEED	000,000,000,000,000,000,000,000,000,000,000,000,000,000,000,000,000,000 020,050,090,100,120,110,100,090,080,060,020,040,060,080,100,040
P48:	INCLINE SPEED	000,000,000,000,000,000,000,000,000,000,000,000,000,000,000,000,000,000 020,040,060,080,120,120,120,080,060,080,100,120,100,080,040,020
P49:	INCLINE SPEED	000,000,000,000,000,000,000,000,000,000,000,000,000,000,000,000,000,000 040,050,060,070,080,090,100,090,080,070,060,050,040,030,020,020
P50:	INCLINE SPEED	002,004,008,000,008,008,005,005,005,005,005,004,004,004,004,004,004,004 020,040,060,100,110,110,120,120,120,100,100,080,060,050,060,040
P51:	INCLINE SPEED	002,002,004,004,010,010,004,004,010,010,004,004,010,010,002,002,002,002 020,040,060,080,100,080,060,040,020,040,060,080,100,080,060,040
P52:	INCLINE SPEED	003,005,006,007,008,009,010,009,008,007,006,005,004,003,002,002,002,002 020,040,060,060,060,060,080,080,080,060,060,060,060,060,040,040,020
P53:	INCLINE SPEED	002,004,006,008,008,010,010,010,010,010,010,009,007,005,003,002,002,002 020,040,060,040,060,080,120,080,060,080,120,080,060,040,060,040
P54:	INCLINE SPEED	002,004,009,004,005,006,007,008,009,004,009,005,006,008,007,005,005,005 020,020,020,060,060,060,100,100,100,040,040,040,040,040,040,040,040

P55:	INCLINE SPEED	002,004,009,004,005,006,007,008,009,010,009,005,006,008,007,005 020,020,040,040,120,120,040,040,120,120,040,040,120,120,020,020
P56:	INCLINE SPEED	002,004,006,008,008,002,004,006,008,008,002,004,006,008,008,002 020,060,040,080,040,080,060,100,060,100,080,100,080,100,060,040
P57:	INCLINE SPEED	002,006,006,006,006,008,010,008,006,006,006,008,006,004,006,004 020,040,060,080,100,020,040,060,080,100,020,040,060,080,100,040
P58:	INCLINE SPEED	003,008,008,002,004,006,008,008,002,004,006,008,008,002,004,006 020,040,060,080,120,120,120,080,060,080,100,120,100,080,040,020
P59:	INCLINE SPEED	002,004,006,008,010,004,004,006,008,010,002,006,008,010,002,004 020,040,060,100,080,040,100,060,040,060,100,040,060,080,060,040
P60:	INCLINE SPEED	002,005,010,008,006,004,006,008,010,008,006,004,006,008,010,008 020,050,050,080,080,080,060,040,030,040,080,080,100,080,060,040
P61:	INCLINE SPEED	002,002,004,004,010,010,004,004,010,010,004,004,010,010,002,002 020,080,060,080,100,080,060,080,080,040,060,080,080,080,060,040
P62:	INCLINE SPEED	004,004,010,010,002,002,004,004,010,004,004,010,004,010,010,002 020,040,060,080,060,100,100,080,040,040,080,100,080,060,040,020
P63:	INCLINE SPEED	002,006,006,006,006,006,006,006,006,006,006,006,006,006,006,006 020,030,030,030,050,050,050,080,080,080,070,070,070,050,050,020
P64:	INCLINE SPEED	002,008,006,008,006,008,006,008,006,008,006,008,006,008,006,008 020,020,020,060,100,040,040,040,040,100,040,040,040,040,060,060
P65:	INCLINE SPEED	002,005,006,007,008,004,005,006,007,008,004,005,006,007,008,004 020,040,080,090,110,110,110,100,070,070,060,060,040,020,020,030
P66:	INCLINE SPEED	002,002,006,010,004,004,010,006,004,006,010,004,006,004,006,004 040,050,060,070,080,090,100,090,080,070,060,050,040,030,020,020
P67:	INCLINE SPEED	002,006,006,006,006,008,010,008,006,006,006,008,006,004,006,006 020,040,040,120,120,040,020,040,040,120,120,040,020,040,040,040
P68:	INCLINE SPEED	002,003,004,004,004,004,004,004,004,004,004,004,004,004,004,004 050,060,100,120,100,080,120,120,060,060,060,080,060,040,060,060
P69:	INCLINE SPEED	002,003,005,008,011,008,007,006,010,010,010,008,004,002,008,010 060,070,060,070,040,040,100,060,040,060,070,060,070,040,080,060
P70:	INCLINE SPEED	002,005,006,005,006,008,010,008,005,008,005,008,006,004,006,004 020,040,060,040,080,060,100,060,100,080,100,040,060,080,060,040
P71:	INCLINE SPEED	002,004,002,004,002,004,002,004,002,004,002,004,002,004,002,004 020,040,060,080,100,080,060,040,020,040,060,080,100,080,060,040
P72:	INCLINE SPEED	002,002,004,004,010,010,004,004,010,010,004,004,010,010,002,002 020,040,060,120,120,080,060,080,120,120,080,060,080,080,080,020
P73:	INCLINE SPEED	002,002,004,008,010,002,004,008,008,010,005,004,007,008,006,004 020,040,060,120,120,080,080,120,080,060,120,060,080,080,040,020

P74:	INCLINE SPEED	002,003,004,005,006,007,008,009,010,009,008,007,006,005,002,002 020,020,020,040,080,090,110,110,110,100,040,040,040,040,040,040
P75:	INCLINE SPEED	002,003,004,005,006,007,008,009,010,002,003,004,005,006,007,008 020,040,040,040,060,080,120,120,040,040,120,120,040,040,020,020
P76:	INCLINE SPEED	002,004,006,010,008,004,010,006,004,006,010,004,006,008,006,004 020,060,080,120,120,040,040,120,120,100,080,100,080,100,060,040
P77:	INCLINE SPEED	002,004,004,004,004,010,004,004,010,006,006,010,004,006,004,006 020,040,060,080,100,020,040,060,080,100,020,040,060,080,100,040
P78:	INCLINE SPEED	002,004,002,003,004,005,006,007,008,010,009,008,007,008,007,006 020,040,060,080,120,120,120,110,110,080,100,100,090,080,040,020
P79:	INCLINE SPEED	004,005,008,006,004,005,004,005,008,006,004,005,004,005,008,006 020,040,060,100,080,040,100,060,040,060,100,080,060,060,060,040
P80:	INCLINE SPEED	002,004,006,004,005,008,006,004,005,008,006,004,005,008,006,004 020,040,060,100,060,100,080,060,100,080,100,040,060,080,060,040
P81:	INCLINE SPEED	002,004,006,008,010,002,004,006,008,010,002,004,006,008,010,002 020,040,060,080,100,080,060,040,020,040,060,080,100,080,060,040
P82:	INCLINE SPEED	002,003,004,007,007,008,005,005,006,010,010,010,008,005,006,004 020,040,060,060,060,100,100,080,080,100,060,060,100,040,040,020
P83:	INCLINE SPEED	002,003,004,008,004,008,006,010,006,010,008,010,008,010,006,004 020,040,100,100,120,080,120,120,110,100,120,080,060,050,050,040
P84:	INCLINE SPEED	002,005,006,005,006,008,010,008,005,008,005,008,006,004,006,004 020,020,020,060,060,060,100,100,100,040,040,040,040,040,040,040
P85:	INCLINE SPEED	002,003,003,003,005,005,005,008,008,008,007,007,007,005,005,002 020,020,040,040,120,120,040,040,120,120,100,100,080,060,050,020
P86:	INCLINE SPEED	002,004,006,010,008,002,005,006,005,006,008,010,008,005,008,005 020,040,060,100,040,040,100,060,040,060,100,040,060,040,060,040
P87:	INCLINE SPEED	002,004,006,002,005,006,005,006,008,012,008,004,006,008,006,004 020,040,060,080,100,100,100,100,090,090,090,080,080,070,040,040
P88:	INCLINE SPEED	002,004,006,002,004,006,002,004,006,002,004,006,002,004,006,002 020,040,060,080,120,120,120,080,120,080,120,080,060,080,100,020
P89:	INCLINE SPEED	002,006,006,006,006,008,010,008,006,006,006,008,006,004,006,006 020,050,090,100,120,110,100,090,080,060,020,040,060,080,100,040
P90:	INCLINE SPEED	002,008,006,008,010,008,006,008,008,004,006,008,008,008,006,004 020,040,060,100,080,040,100,060,040,060,100,040,060,080,060,040
P91:	INCLINE SPEED	002,003,003,003,005,005,005,008,008,008,007,007,007,005,005,002 020,040,040,040,060,060,060,080,080,040,060,080,100,080,060,040
P92:	INCLINE SPEED	002,004,006,010,002,004,006,010,002,004,006,010,002,004,006,010 020,040,060,060,060,060,080,080,080,060,060,060,060,060,040,040,020

P93:	INCLINE SPEED	002,005,006,005,006,008,010,008,005,008,005,008,006,004,006,004 020,040,060,040,060,080,120,080,060,080,120,080,060,040,060,040
P94:	INCLINE SPEED	002,004,005,006,008,010,008,005,008,005,008,006,004,006,010,004 020,020,020,060,060,060,100,100,100,040,040,040,040,040,040
P95:	INCLINE SPEED	002,004,006,008,002,004,006,008,002,004,006,008,002,004,006,008 020,020,040,040,120,120,080,060,100,040,040,120,120,020,020,020
P96:	INCLINE SPEED	002,004,006,008,008,002,004,006,002,004,006,008,008,002,004,006 020,060,040,080,040,080,060,100,060,100,080,100,080,100,060,040
P97:	INCLINE SPEED	002,004,006,008,008,002,004,006,008,008,002,004,006,008,008,002 020,040,060,080,100,020,040,060,080,100,020,040,060,080,100,040
P98:	INCLINE SPEED	002,004,006,010,002,004,006,010,002,004,006,010,002,004,006,010 020,040,060,100,120,120,120,110,060,080,100,120,100,080,040,020
P99:	INCLINE SPEED	002,004,060,008,008,010,010,010,010,010,010,010,010,010,010,005 020,040,060,080,080,090,090,120,120,120,110,040,060,080,060,040