

CORSAIR FREERUN 200 TREADMILL OWNER'S MANUAL



Product may vary slightly from the item pictured due to model upgrades

Read all instructions carefully before using this product. Retain this owner's manual for future reference.

TABLE OF CONTENTS

1.	IMPORTANT SAFETY INSTRUCTIONS	3
2.	IMPORTANT OPERATING INSTRUCTIONS	3
3.	EXPLODED DIAGRAM	5
4.	PARTS LIST	6
5.	ASSEMBLY INSTRUCTIONS	10
6.	FEATURE & FUNCTION	14
7.	EXERCISE GUIDE	22
8.	MAINTENANCE INSTRUCTIONS	24
9.	WARRANTY	25

1. IMPORTANT SAFETY INSTRUCTIONS

WARNING- Read all instructions before using this treadmill.

It is important your treadmill receives regular maintenance to prolong its useful life. Failing to regularly maintain your treadmill may void your warranty.

- Read the entire owner's manual before operating the unit.
- Save this manual for future reference.
- Assembly of Technical Items: Assembly of the treadmill should be performed by a qualified technician. A significant amount of technical knowledge is required for the safe and complete assembly of the unit.
- Do not use accessory attachments that are not recommended by Lifespan Fitness. Such attachments may cause injuries.
- Assemble and operate the treadmill on a solid, level surface.
- All warning labels attached directly to the treadmill must remain installed. If a warning label becomes illegible or damaged, please contact Lifespan Fitness for a replacement.
- Maintain the treadmill to keep it in good working condition, as described in this manual. Inspect the treadmill for incorrect, worn, or loose components, and then correct, replace, or tighten prior to use.
- If you plan to move the treadmill, obtain help and use proper lifting techniques.
- Do not attempt to service the treadmill yourself, except to follow the maintenance instructions in this manual.
- The equipment should
- Move the treadmill with 2 person and use proper lifting technique to avoid injury.

2. IMPORTANT OPERATING INSTRUCTIONS

- Do not use while under the influence of alcohol, drugs, or narcotics.
- Do not allow children, or people unfamiliar with the operation of this treadmill, on or near it. Do not leave children unsupervised around the treadmill.
- Do not allow children under the age of 16 to use the treadmill.
- Do not allow animals on the treadmill.
- Examine the treadmill for loose or worn parts before each use. Tighten/replace any worn or loose components prior to use.
- Do not use outdoors or in high humidity.

 **WARNING:** The treadmill is non-motorized and means the user initiates and controls the speed of the running belt. There is no emergency stop feature and the treadmill will slow to a stop on its own.

 **WARNING:** The belt moves freely in only one direction. Grasp the handrails whenever mounting and dismounting the treadmill.

- ❑ Do not operate the treadmill without the handrail installed.
- ❑ Do not use the treadmill with walking poles or other devices not specifically approved by Lifespan Fitness.
- ❑ Never jump onto the treadmill. Never jump from the treadmill. Never enter the treadmill from the front. Operate treadmill only when facing forward. Never attempt to mount or dismount the treadmill while the belt is moving.
- ❑ Hold on to the handrail with one hand whenever you operate the console keys with the other hand. Face the console and do not lean on or pull on the console at any time.
- ❑ Never drop or insert objects into any opening.
- ❑ Keep hands away from moving parts.
- ❑ Wear proper exercise clothing and shoes for your workouts and avoid loose or dangling clothing. Tie long hair back. Do not wear shoes with heels and check the soles of your shoes to remove any dirt and embedded stones. The running surface is not intended for cleats or running spikes.
- ❑ Save these instructions.

3. EXPLODED DIAGRAM

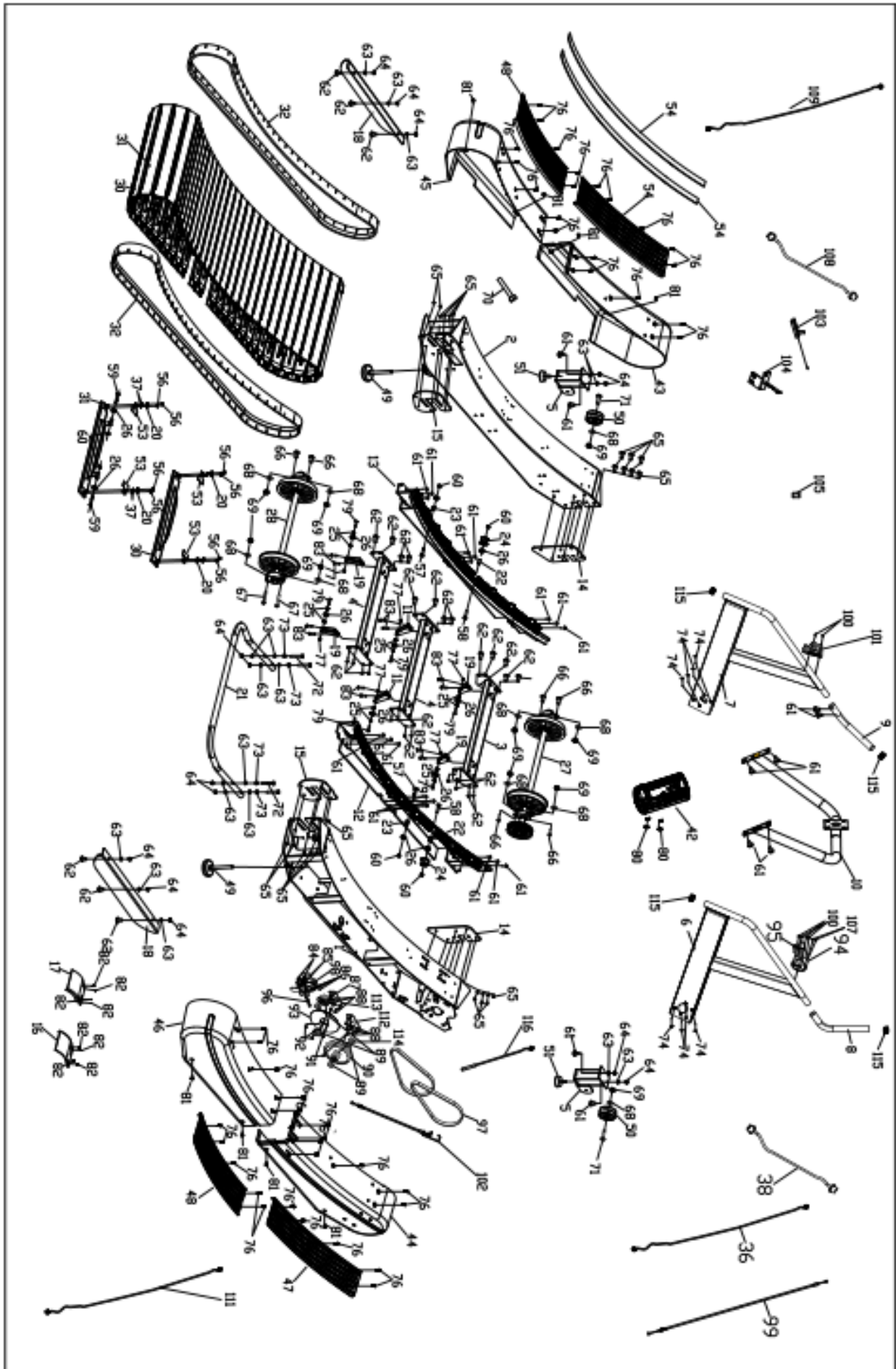

4. PARTS LIST

No.	Description	Qty	No.	Description	Qty
1	Main Frame (R)	1	62	Hexagon C.K.S full thread screw M8×20	26
2	Main Frame (L)	1	63	Flat washer Φ8	18
3	Front connecting tube	1	64	Hex locking nut M8	14
4	Connecting tube	2	65	Hexagon C.K.S full thread screw M8×10	26
5	Front wheel fixed tube	2	66	Hexagon C.K.S full thread screw M10×25×15	6
6	Upright post (R)	1	67	Hexagon C.K.S full thread screw M10×45×20	2
7	Upright post (L)	1	68	Flat washer Φ10	10
8	Handlebar (R)	1	69	Hex locking nut M10	10
9	Handlebar (L)	1	70	Hexagon full thread screw M12×95	2
10	Console frame	1	71	Hexagon C.K.S half thread screw M10×55×25	2
11	Clamping ring		72	Hexagon full thread screw M8×50	4
12	Bearing fixed plate (R)	1	73	Hex locking nut M8	4
13	Bearing fixed plate (L)	1	74	Hexagon C.K.S half thread screw M8×65×20	8
14	Front roller reinforcing plate	2	75	Allen socket full thread screw M8×75	1
15	Rear roller reinforcing plate	2	76	Philips C.K.S. full thread screw M4×15	40
16	Reinforcing plate (R)	1	77	Hex locking nut M6	16
17	Reinforcing plate (L)	1	78	Allen full thread screw M6×15	4
18	Fixing plate	2	79	Allen socket full thread screw M6×25	6
19	Clamping ring	1	80	Philips C.K.S. full thread screw M5×10	4
20	Spacer	120	81	Philips C.K.S. full thread screw M5×15	12
21	Main frame lifting handle tube	1	82	Philips C.K.S. full thread screw	10
22	Sleeving	18	83	Allen socket full thread screw M4×10	12
23	Sleeving	88	84	Philips C.K.S. full thread screw M5×10	4
24	Guiding wheel	18	85	Cover for magnet	2
25	Sleeving	12	86	Round magnet	4
26	Bearing	172	87	Drive shaft	1
27	Front roller	1	88	Allen socket full thread screw M8×20	6
28	Rear roller	1	89	Deep groove ball bearing	4
30	Aluminum chain 1	30	90	Driving wheel	1
31	Aluminum chain 2	30	91	Circlip for shaft	2
32	Running belt fixing strap	2	92	Allen full thread screw M6×10	3
36	Wire L-1250mm	1	93	Aluminum plate for driving wheel	1
37	Washer Φ6	240	94	Handlebar	1
38	Wire L-900mm	1	95	Allen C.K.S. half thread screw M8×55×13	1
42	Console	1	96	Cylindrical spiral springs	1
43	Front cover (L)	1	97	Elastic belt	2
44	Front cover (R)	1	98	Welding part for magnet set	1
45	Rear cover (L)	1	99	Communication cable for resistance L-1150mm	1
46	Rear cover (R)	1	100	Philip C.K.S. self-tapping screw ST4×16	2
47	Antiskid plate 1	2	101	Bottle holder	1
48	Antiskid plate 2	2	102	Communication cable for resistance L-450mm	1
49	Horizontal adjustment feet pad	2	103	Slide rheostat	1
50	Wheel	2	104	Slide rheostat fix plate	1
51	Horizontal adjustment feet pad	2	105	Brake line fix plate	1
53	PVC Spacer	120	107	Self-tapping screw ST3×10	2
53	PVC Spacer	120	108	VR Communication cable L-950mm	1
54	PVC plastic strip	2	109	VR Communication cable L-1250mm	1

56	Hex locking nut M5	240	111	VR Communication cable L-500mm	1
57	Hexagon half thread screw M8*36*11	88	112	Fixed axle ONE	1
58	Hexagon half thread screw M8*40*13	18	113	Fixed axle TWO	1
59	Hexagon socket head full thread screw M8*48*15	60	114	Single way bearing CSK12P	1
60	Hex locking nut Φ8	106	115	Tube plugΦ38	4
61	Hexagon C.K.S full thread screw M8×20	30	116	Communication cable L-550mm	1

Packing List

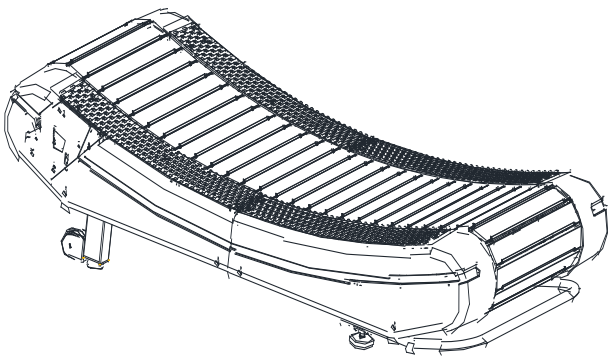

Main body

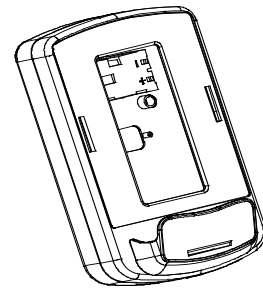

Console

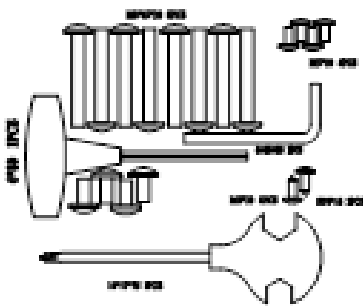

Hardware pack

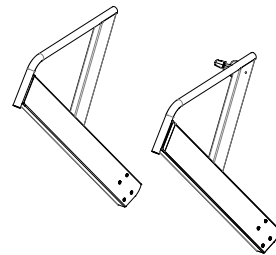

Upright post

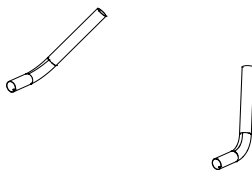

Handlebar L/R

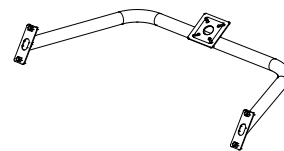

Console

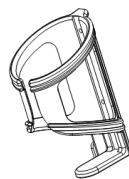

Bottle holder

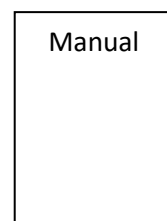

User manual

Hardware Pack List

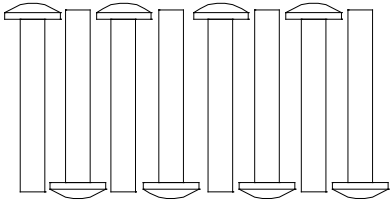

Hexagon C.K.S half thread screw
M8×65×20 8pcs

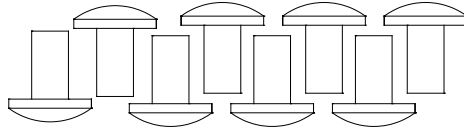

Hexagon C.K.S half thread screw
M8*20 8pcs

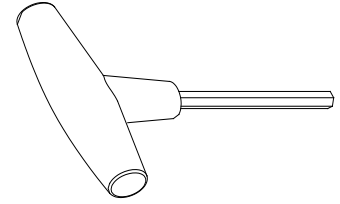

T-shape spanner 6*80 1pc

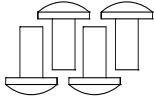

Hexagon C.K.S half thread screw
M5*10 4pcs

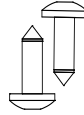

Self-tapping screw ST4×16 2pcs

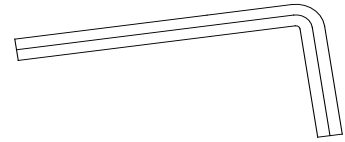

L-shape spanner 6*35*80 1pc

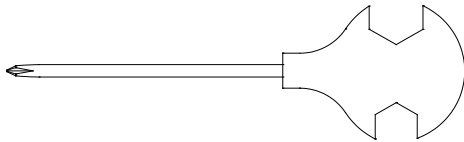

Cross spanner 14*17*75 1pc

Main Parts

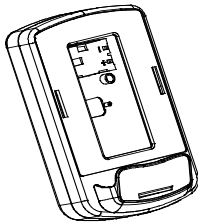

Console

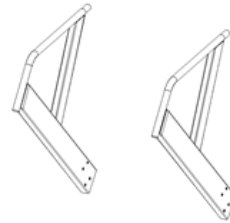

Upright post

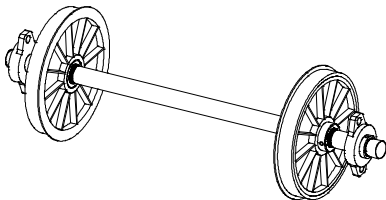

Front roller

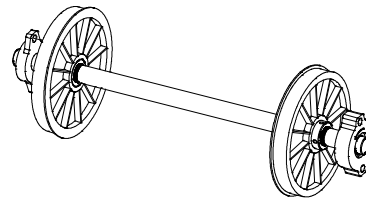

Rear roller

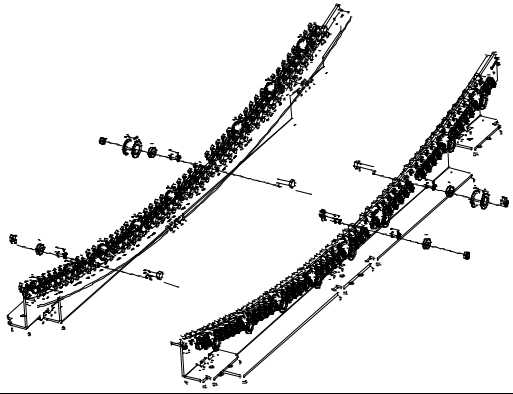

Bearing fixed set

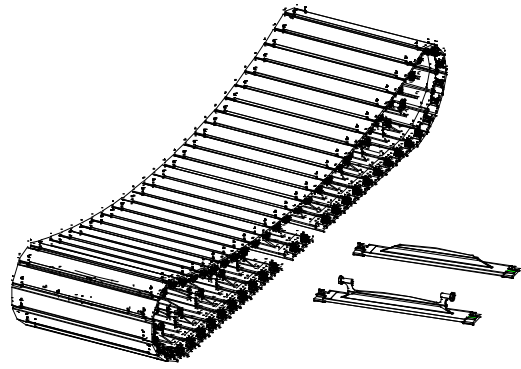

Aluminum chain



Handle for resistance adjusting

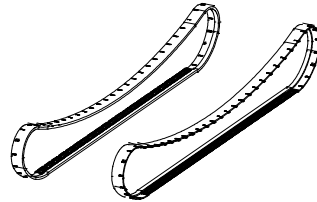

Running belt fixing strap

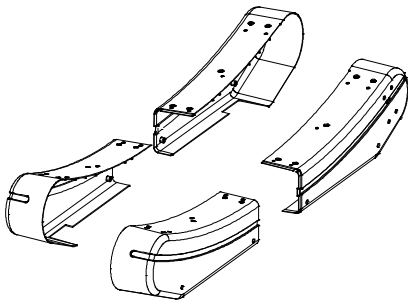

Main frame cover

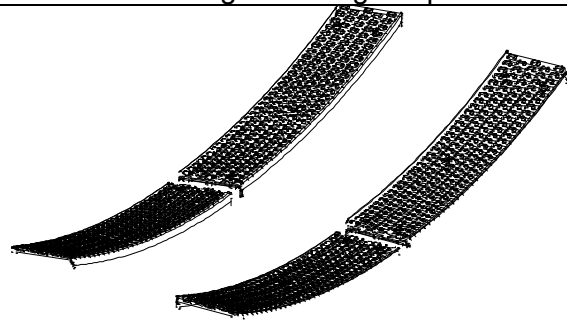

Anti-skate

5. ASSEMBLY INSTRUCTIONS

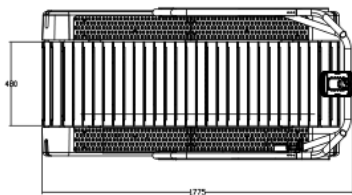
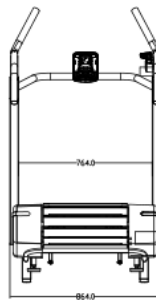
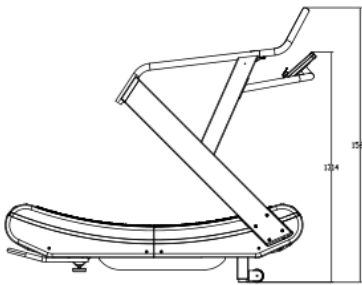
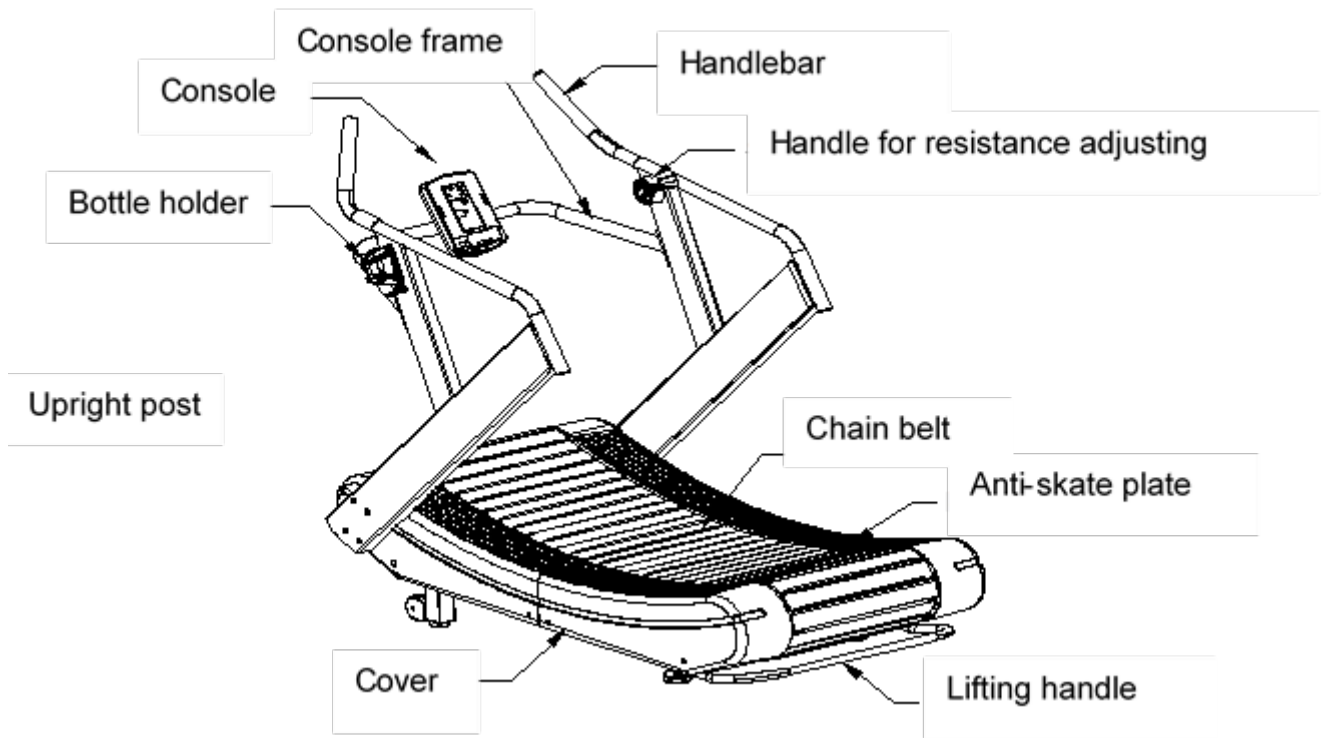

Step 1

1. Take out the console frame and console from the box, connect the console communication wire then fix on the console frame with 4PCS M5X10 screws.

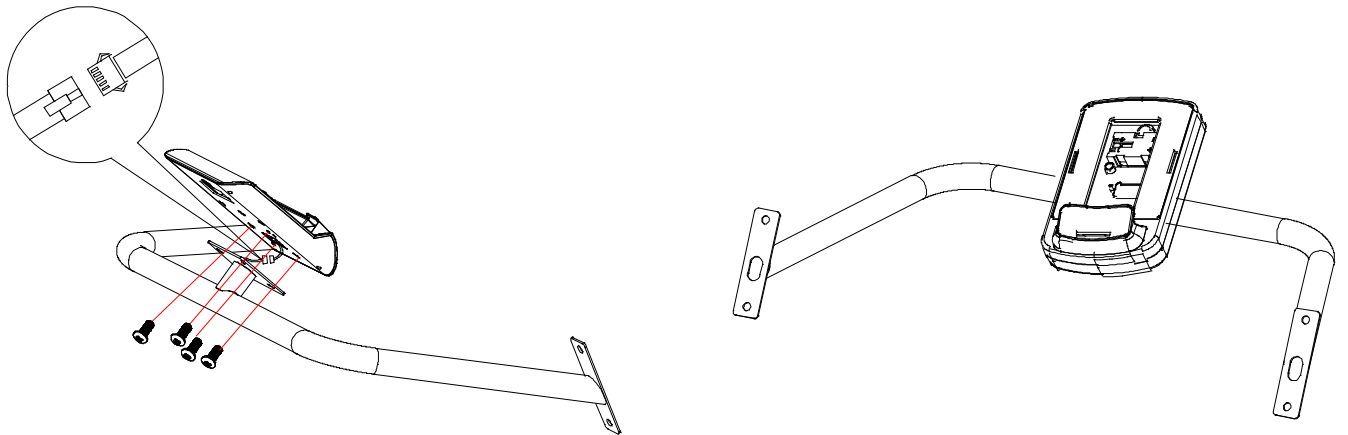

Step 2:

1. Take out the machine from the box and put it on the even floor.
2. Connect the communication wire in the right upright post, then fix the upright post with 4pcs M8x65x20 screws. Then assemble the left upright post.

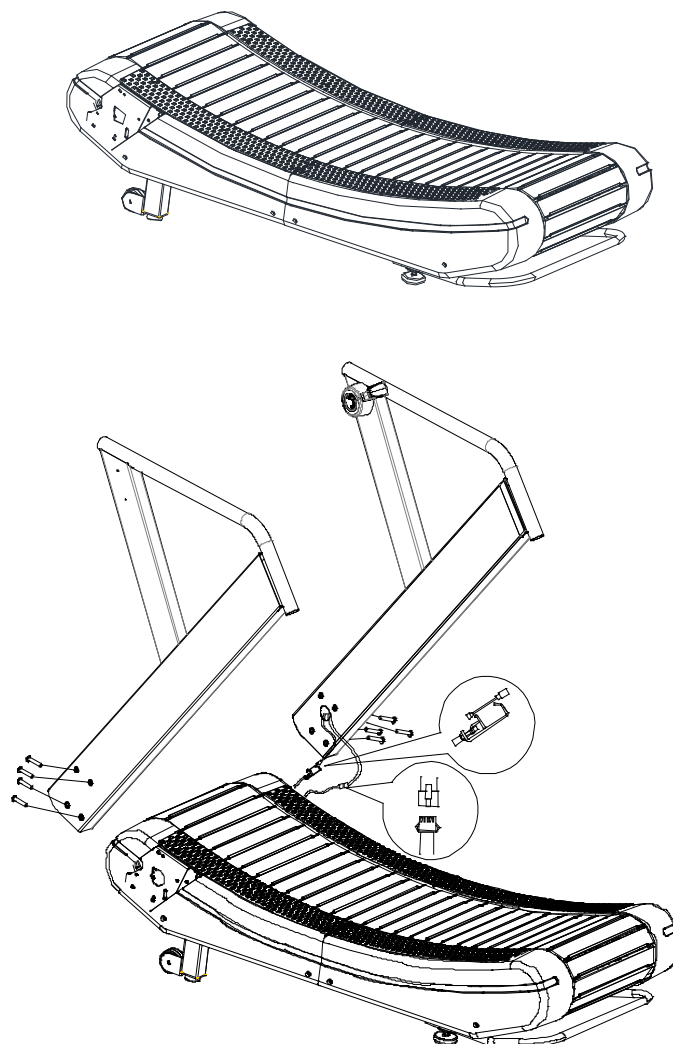

Step 3:

1. Connect the right handlebar and right upright post with 2pcs M8*20 screw. Fix the left handlebar in the same way.

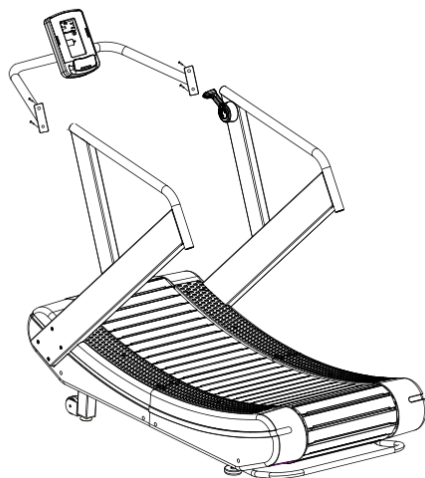

Step 4:

1. Connect the communication wire between handlebar and the console frame, then fix the console frame with 4pcs M8*20 screws, tighten all the screws.

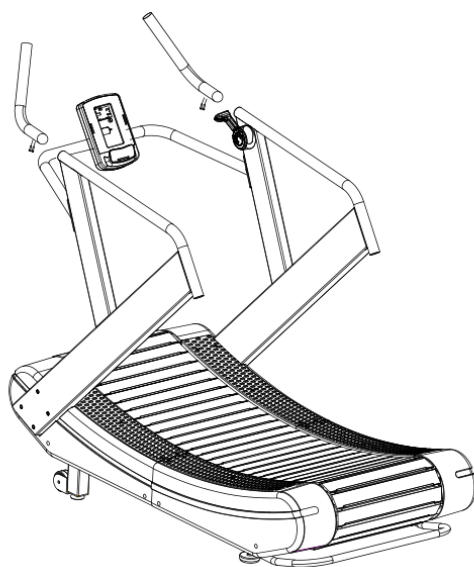

Step 5:

1. Install the drink bottle holder.
2. Treadmill installation is finished.

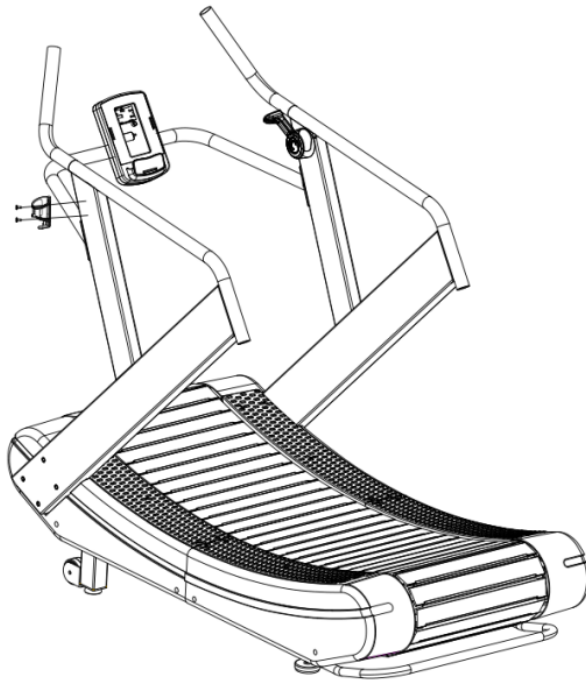

6. FEATURE AND FUNCTION

DISPLAY FUNCTIONS:

Item	Description
TIME	Display user workout time. Display range 0:00~1:59:00
DISTANCE	Display user workout distance. Display range 0.5~100
CALORIES	Display calories consumption during workout. Display range 0 ~ 2000
PULSE	Display user heartrate during workout. Display range 30~230
WATT	Display the power consumption during training
SPEED	Display current training speed
PACE	Set the time to reach the target distance
Load	Display LOAD resistance value for each level in WATT window when adjust LOAD resistance Display range L1~L4

BUTTON FUNCTION:

Item	Description
Up ▲	Adjust function value up.
Down ▼	Adjust function value down.
Enter	Confirm setting or selection.
Start	Start work out quickly or resume workout in Stop mode.
Stop	To stop/pause workout. Hold on this key for 2 seconds to reboot the console.
Interval	There are 3 programs: INTERVAL 10/20, INTERVAL 20/10, Custom Interval.
Target Distance	Fast access to Target Distance training mode.
Target Calories	Fast access to Target Calories training mode.

Target Heartrate	Fast access to Target Heart Rate training mode.
Target Time	Fast access to Target Time training mode.

OPERATION PROCEDURE:

Power on

1. When POWER ON, LCD will full display 1s (Figure 1) with long beep sound, then enter display standby mode (FIG 2), the pictures will be displayed from top ICON to bottom in sequence. Press STOP button for 2 second, then enter standby mode.

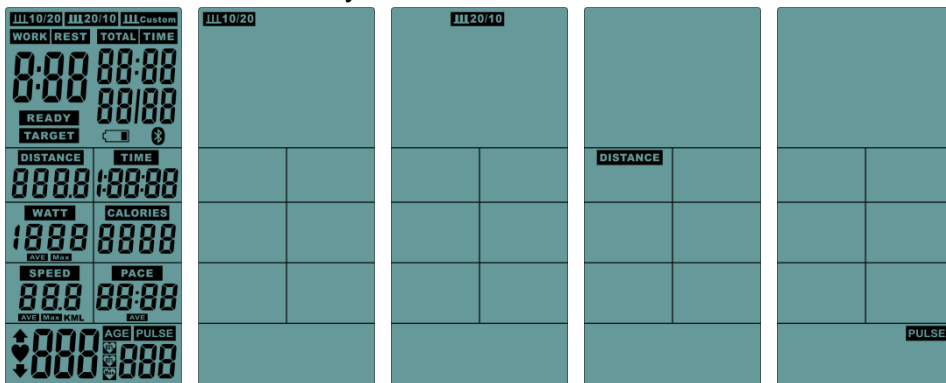

(FIG 1) (FIG 2)

2. If no input of key operation or RPM signal input in 4Min, LCD will go to Sleeping mode (FIG 3).

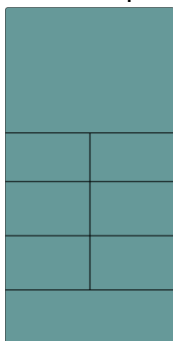

(FIG 3)

3. Break mode:

When START, press “START” button one time, enter into Break mode with buzzer sound 0.5s by every 30s. Computer still display all functions ,but LCD windows display “P” .Buzzer will sound for 1s and enter into standby mode after broke with 5 Min, then press ” START “to continue. (FIG 4)



(FIG 4)

4. Stop mode:

Press “STOP” button with buzzer sound 0.5s, enter Stop mode.

All the LCD windows no display, but after 0.5s LCD will display TIME, DIST, CAL (display KM or ML according to the setting).

After 7s with buzzer sound 0.25s, LCD display MAX ICON, WATTS, SPEED, PULSE, also after keep shows 7s with buzzer sound 0.25s, LCD display AVE ICON WATTS, SPEED, PACE, after keep shows 7s without display any data at the moment, then re-show the data two times and enter into standby mode. (FIG 5)



(FIG 5)

5. Quick start:

In standby mode, with single RPM>20 input, quick press “START”, buzzer sound 0.5s, then TIME, CALORIES, DISTANCE, WATTS, SPEED, & PACE shining in in sequence, the value will count up according to the operation.

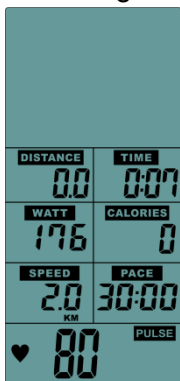

(FIG 6)

- A.** “PULSE” ICON: if any heart single input the “PULSE” ICON is flashing with current value, if no heart single input LCD display “P”.
- B.** If without any single input within 5Min, the buzzer rings for 0.5s and computer will go back to standby mode.
- C.** If setting is not completed in 30 seconds, the buzzer will ring for 0.5 seconds and go back to standby mode.
- D.** Press the “START” button once to enter the break mode, and press “START” to continue running.
- E.** Press the “STOP” button to sound the buzzer for 0.5 seconds and enter the stop mode.
- F.** If the result of movement is displayed, press “STOP” button to leave and return to standby mode.
- G.** When adjusting the adjustment button, it will display the LOAD resistance for each segment in WATT window.

6. INTERVAL10/20:

- A. Press "INTERVAL10/20" button, enter to this mode, LCD display **III10/20** ICON, with buzzer beeps 0.5s.
- B. If there is no input in 30s when setting, the computer will back to standby mode.
- C. The "READY" ICON counts down from 3s to 0s, meanwhile with a short buzzer beep (FIG 7), LCD display "01/XX" ("01" is flashing). The "WORK" ICON is flashing one time every 1s with buzzer sounds (shining 0.75s/ put out 0.25s), "TIME" ICON counts down from 10s to 0s, DISTANCE, CALORIES, WATTS, SPEED, RPM count-up according the operation. (FIG 8)

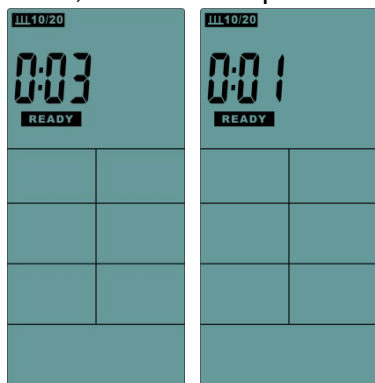

(FIG 7)

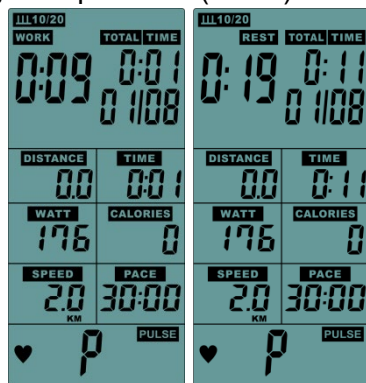

(FIG 8)

- D. After Work 10s, LCD window display "01/08" ("01" is flashing), "REST" ICON is kept flashing, the buzzer rings for 0.25s per 1s, TIME start to count down from 20s to 0s.
- E. Work & REST display in cycle, cycle count increase 1 every time till reach to 08/08 (total cycle counts 8 times). Buzzer rings 0.5s enter to stop mode. (The average value of the sports results is only calculated within the Work time)
- F. when the last REST is reached, this mode is stop directly.
- G. If no single input in 5Min, buzzer rings 0.5s enter standby mode.
- H. Press the "START" button once, enter the break mode, and press "START" to continue running.
- I. Press the "STOP" button to sound the buzzer for 0.5s and enter the stop mode.
- J. If the result of movement is displayed, press "STOP" button to leave and return to standby mode.

7. INTERVAL 20/10:

- A. Press "INTERVAL 20/10" button, enter to this mode, LCD display **III20/10** ICON (FIG 10), with buzzer beeps 0.5s.
- B. If did not input in 30s when setting, computer will back to standby mode.
- C. The "READY" ICON counts down from 3s to 0s, meanwhile with a short buzzer beep (FIG 7), LCD display "01/XX" ("01" is flashing). The "WORK" ICON is flashing one time every 1s with buzzer sounds (shining 0.75s/ put out 0.25s), "TIME" ICON counts down from 10s to 0s, DISTANCE, CALORIES, WATTS, SPEED, RPM count according the operation. (FIG 10).



(FIG 10)

- D. After Work 10s, LCD window display "01/08" ("01" is flashing), "REST" ICON is kept flashing, the buzzer rings for 0.25 seconds per second, TIME start to count down from 20s to 0s.
- E. Work & REST display in cycle, cycle count increase 1 every time till reach to 08/08 (total cycle counts 8 times). Buzzer rings 0.5s enter to stop mode. (The average value of the sports results is only calculated within the Work time)
- F. when the last REST is reached, this mode is stop directly.
- G. If no single input in 5Min, buzzer rings 0.5s enter standby mode.
- H. Press the "START" button once to enter the break mode, and press "START" to continue running.
- I. Press the "STOP" button to sound the buzzer for 0.5s and to enter the stop mode.
- J. If the result of movement is displayed, press "STOP" button to leave and return to standby mode.

8. INTERVAL CUSTOM:

- A. Press "INTERVAL CUSTOM" button, enter to this mode, LCD display **III Custom** ICON (FIG 13), with buzzer beeps 0.5s.
- B. LCD display the presetting value 01, press "UP, DOWN" button to setting (setting range 01~20), it is non-recyclable (FIG 14).
- C. Press "ENTER" confirmed, "WORK" ICON is flashing, LCD window "TOTAL TIME" display the presetting value 0:30. Press "UP, DOWN" button to setting (setting range: 0:05~30:00), it is non-recyclable (FIG 15).
- D. Press "ENTER" confirmed, "REST" ICON is flashing, LCD window "TOTAL TIME" display the presetting value 0:20. Press "UP, DOWN" button to setting (setting range: 0:05~30:00), it is non-recyclable (FIG 16).
- E. Press "ENTER" confirmed, meanwhile with a short buzzer rings 0.5s, LCD display "01/XX" ("01" is flashing). The "WORK" ICON is flashing one time every 1s with buzzer sounds (shining 0.75s/ put out 0.25s), "TIME" ICON counts down from the setting value, DISTANCE, CALORIES, WATTS, SPEED, PACE count according the operation.
- F. There is set REST time, matrix displays 01/XX (part 01 is flashing), "REST" ICON keep flashing, The buzzer rings for 0.25s every second.
- G. "Work" & "REST" display in cycle, cycle count increase 1 every time till reach to 08/08 (total cycle counts 8 times). Buzzer rings 0.5s enter to stop mode. (The average value of the sports results is only calculated within the Work time)
- H. When the last REST is reached, this mode is stop directly.
- I. If no single input in 5Min, buzzer rings 0.5s enter standby mode.
- J. Press the "START" button once, enter the break mode, and press "START" to continue running.
- K. Press the "STOP" button to sound the buzzer for 0.5 seconds and enter the stop mode.
- L. If the result of movement is displayed, press "STOP" button to leave and return to standby mode.



(FIG 14)

(FIG 15)

(FIG 16)

9. TARGET TIME:

- A. Press "TARGET TIME" button to enter to this mode, LCD flashing will display TARGET & TIME.
- B. LCD "TIME" window displays the presetting value 1:00 or the last setting value. Press "UP, DOWN" button to setting (setting range 1:00~1:59:00), it is non-recyclable.
- C. After setting, press "ENTER" confirmed, TARGET & TIME ICON continue to flash, meanwhile start to count down from setting value.
- D. Press the "START" button once, enter the break mode, and press "START" to continue running.
- E. Press the "STOP" button to sound the buzzer for 0.5s and enter the stop mode.
- F. If no single input in 5Min, buzzer rings 0.5s enter standby mode.
- G. If did not complete the setting in 30s, the buzzer rings for 0.5s and back to standby mode.
- H. If the result of movement is displayed, press "STOP" button to leave and return to standby mode.

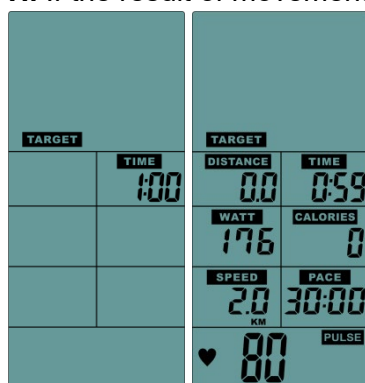

10. TARGET CALORIES:

- A. Press "TARGET CALORIE" button, enter to this mode, LCD flashing display TARGET & CALORIE.
- B. LCD "CALORIE" window display the presetting value 2:00 or the last setting value. Press "UP, DOWN" button to setting (setting range 1~2000), it is non-recyclable.
- C. After setting, press "ENTER" confirmed, TARGET & CALORIE ICON continue to be flashing, meanwhile start to count down from the setting value.
- D. Press the "START" button once, to enter the break mode, and press "START" to continue running.
- E. Press the "STOP" button to sound the buzzer for 0.5s and enter the stop mode.
- F. If no single input in 5Min, buzzer rings 0.5s enter standby mode.
- G. If did not complete the setting in 30s, the buzzer rings for 0.5s and back to standby mode.
- H. If the result of movement is displayed, press "STOP" button to leave and return to standby mode.

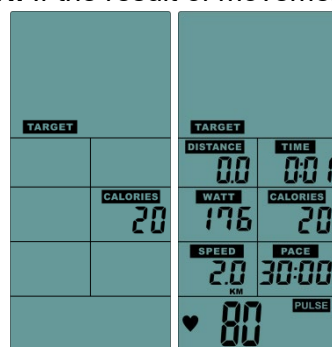

11. TARGET DISTANCE:

- A. Press "TARGET DISTANCE" button, enter to this mode, LCD flashing display TARGET & DISTANCE.
- B. LCD "DISTANCE" window display the presetting value 0.5KM/0.5Miles or the last setting value. Press "UP, DOWN" button to setting (setting range 0.5~100), it is non-recyclable.
- C. After setting, press "ENTER" confirmed, TARGET & DISTANCE continue to be flashing, meanwhile start to count down from the setting value.

- D. Press the “START” button once, enter the break mode, and press “START” to continue running.
- E. Press the “STOP” button to sound the buzzer for 0.5s and enter the stop mode.
- F. If no single input in 5Min, buzzer rings 0.5s enter standby mode.
- G. If did not complete the setting in 30s, the buzzer rings for 0.5s and back to standby mode.
- H. If the result of movement is displayed, press “STOP” button to leave and return to standby mode.

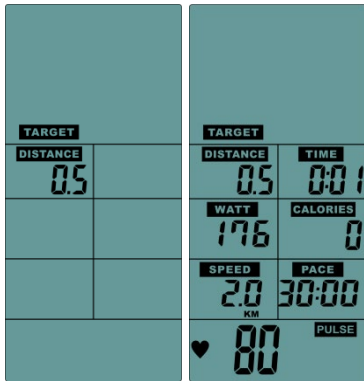

12. TARGET HEART RATE:

- A. Press” TARGETHEART RATE” button, enter to this mode, LCD flashing display Age ICON with presetting value 30 or the last setting value. Press “UP, DOWN” button to setting (setting range 11~99), it is non-recyclable.
- B. After setting, press “ENTER” confirmed, LCD display the presetting value 65%, press “UP, DOWN” button to adjust to 65% or 85% & the value of Pulse, LCD will show the corresponding value.
- C. If selected PULSE, LCD display the presetting value “100”, press “UP, DOWN” button to setting (setting range 30~230), it is non-recyclable.
- D. Press “ENTER” button to start to count, TARGET & PULSE ICON is flashing.
- E. When the heartbeat value is higher or lower than the setting value (+/-10%), the PULSE value is displayed continuously.
- F. The heartbeat value is lower than the setting value (<10%), and the PULSE window "UP IOCN" flashes to remind USER to accelerate.
- G. The heartbeat value is higher than the setting value (>10%), and the PULSE window "DOWN IOCN" flashes to remind USER to slow down
- H. The heartbeat value is higher than or equal to the setting value of 100%. The buzzer rings 3 short sounds every 1s. After 10 times, the heartbeat value is still not lower than 100%, the buzzer rings 1s and enter the standby mode.
- I. Without any heart single input in 30s, the “PULSE” LCD window display “P”, buzzer rings 1s and enter the standby mode.
- J. Press the “START” button once, enter the break mode, and press “START” to continue running.
- K. Press the “STOP” button to sound the buzzer for 0.5 seconds and enter the stop mode.
- L. If no single input in 5Min, buzzer rings 0.5s enter standby mode.
- M. If did not complete the setting in 30s, the buzzer rings for 0.5s and back to standby mode.
- N. If the result of movement is displayed, press “STOP” button to leave and return to standby mode.

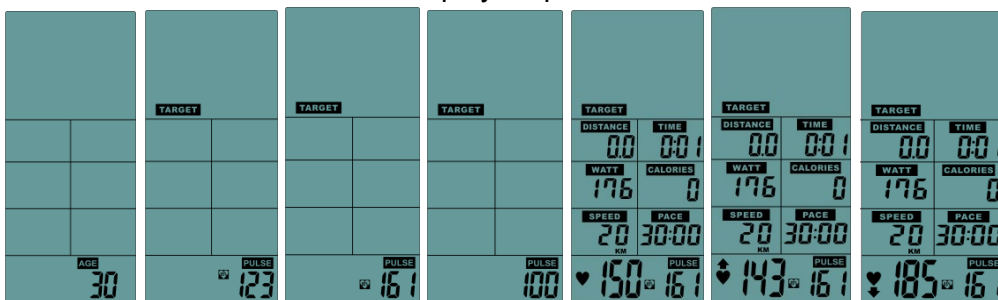

Set Age 65% 85% PULSE START < TARGET10% > TARGET10%

Moving the Treadmill

How to move treadmill:

1. Hold the treadmill from the back with both hands.
2. Tilt it to the transportation wheels and move the desired location.

CAUTION: The machine is heavy and may need assistance to move it.

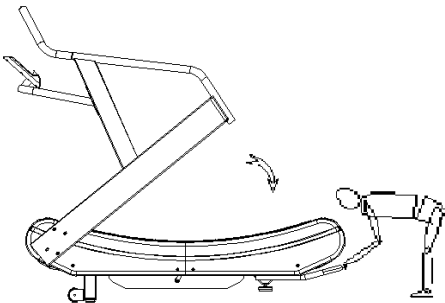
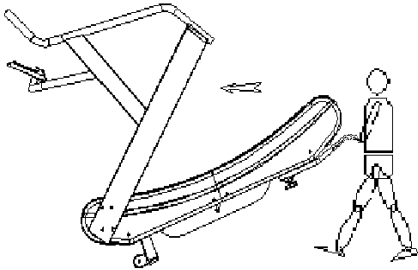
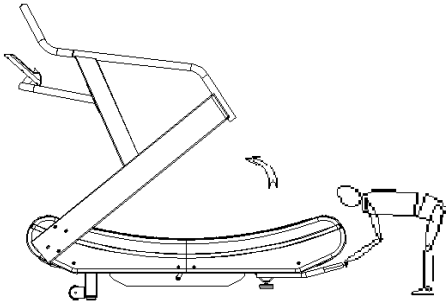

7. EXERCISE GUIDE

PLEASE NOTE: Before beginning any exercise program, consult your physician. This is important especially if you are over the age of 45 or individuals with pre-existing health problems.

The pulse sensors are not medical devices. Various factors, including the user's movement, may affect the accuracy of heart rate readings. The pulse sensors are intended only as an exercise aid in determining heart rate trends in general.

Exercising is great way to control your weight, improving your fitness and reduce the effect of aging and stress. The key to success is to make exercise a regular and enjoyable part of your everyday life.

The condition of your heart and lungs and how efficient they are in delivering oxygen via your blood to your muscles is an important factor to your fitness. Your muscles use this oxygen to provide enough energy for daily activity. This is called aerobic activity. When you are fit, your heart will not have to work so hard. It will pump a lot fewer times per minute, reducing the wear and tear of your heart.

So as you can see, the fitter you are, the healthier and greater you will feel.

Warm-up

Start each workout with 5 to 10 minutes of stretching and some light exercises. A proper warm-up increases your body temperature, heart rate and circulation in preparation for exercise. Ease into your exercise.

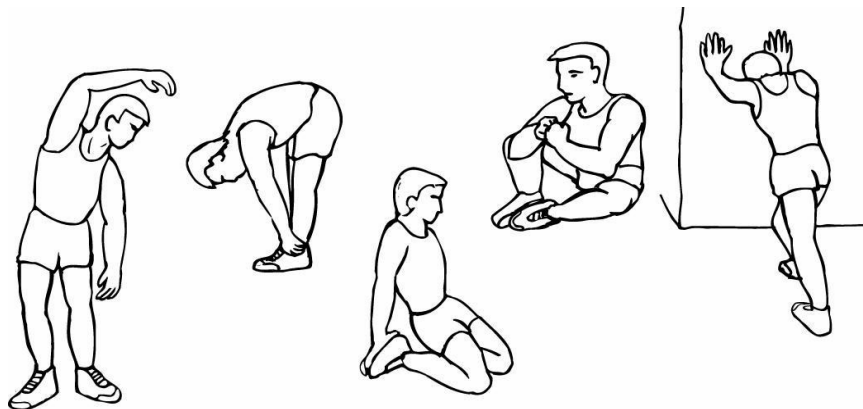

Training Zone Exercise

After warming up, increase the intensity to your desired exercise program. Be sure to maintain your intensity for maximum performance. Breathe regularly and deeply as you exercise.

Cool Down

Finish each workout with a light jog or walk for at least 1 minute. Then complete 5 to 10 minutes of stretching to cool down. This will increase the flexibility of your muscles and will help prevent post-exercise problems.

Workout Guidelines

TARGET ZONE

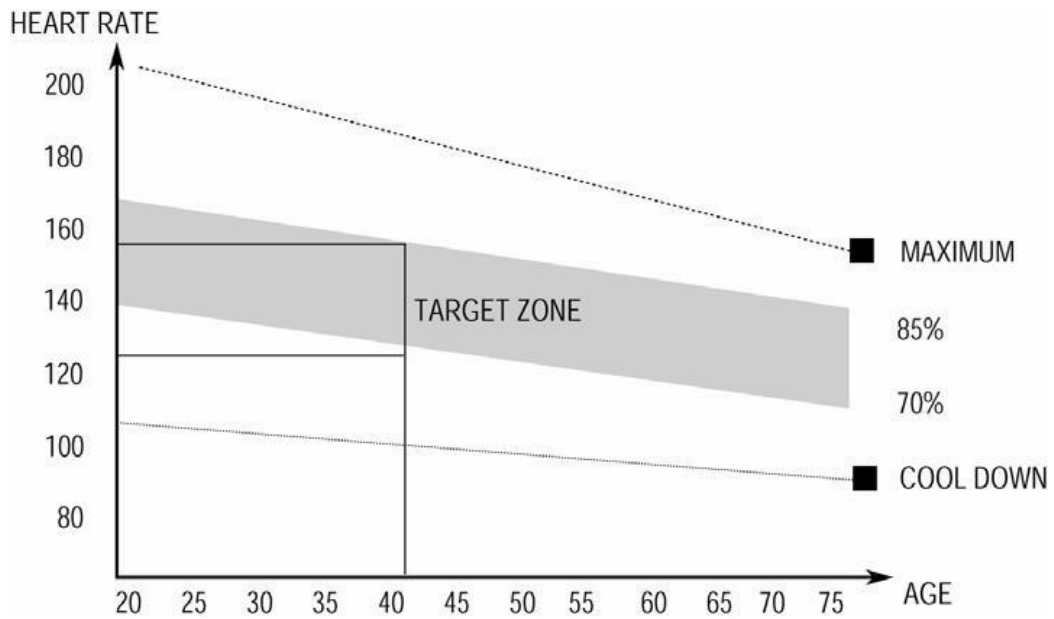

This is how your pulse should behave during general fitness exercise. Remember to warm up and cool down for a few minutes.

The most important factor here is the amount of effort you put in. The harder and longer you work, the more calories you will burn.

8. MAINTENANCE INSTRUCTIONS

Reasonable cleaning/lubricating should be made to extend the lifetime of this unit. Performance is maximized when the belt and mat are kept as clean as possible.

WARNING: THE MAT/DECK FRICTION MAY PLAY A MAJOR ROLE IN THE FUNCTION AND LIFE OF YOUR TREADMILL AND THAT IS WHY WE RECOMMEND YOU CONSTANTLY LUBRICATE THIS FRICTION POINT TO PROLONG THE USEFUL LIFE OF YOUR TREADMILL. FAILING TO DO THIS MAY VOID YOUR WARRANTY.

1. General Cleaning

- Use a soft, damp cloth to wipe the edge of the belt and the area between the belt edge and frame. A mild soap and water solution along with a nylon scrub brush will clean the top of the textured belt. This task should be done daily. Allow to dry before using.

2. General Care

- Check parts for wear before use.
- Pay particular attention to the fixing knobs and make sure they are tight.
- Always replace the mat if worn and any other defective parts.
- If in doubt do not use the treadmill and contact us.

TAKE CARE TO PROTECT CARPETS AND FLOOR in case of leakages. This product is a machine that contains moving parts which have been greased / lubricated and could leak

9. WARRANTY

AUSTRALIAN CONSUMER LAW

Many of our products come with a guarantee or warranty from the manufacturer. In addition, they come with guarantees that cannot be excluded under the Australian Consumer Law. You are entitled to a replacement or refund for a major failure and compensation for any other reasonably foreseeable loss or damage.

You are entitled to have the goods repaired or replaced if the goods fail to be of acceptable quality and the failure does not amount to a major failure. Full details of your consumer rights may be found at www.consumerlaw.gov.au

Please visit our website to view our full warranty terms and conditions:
<http://www.lifespanfitness.com.au/warranty-repairs>

Warranty and Support:

Please email us at support@lifespanfitness.com.au for all warranty or support issues.

For all warranty or support related enquiries an email must be sent before contacting us via any other means.