

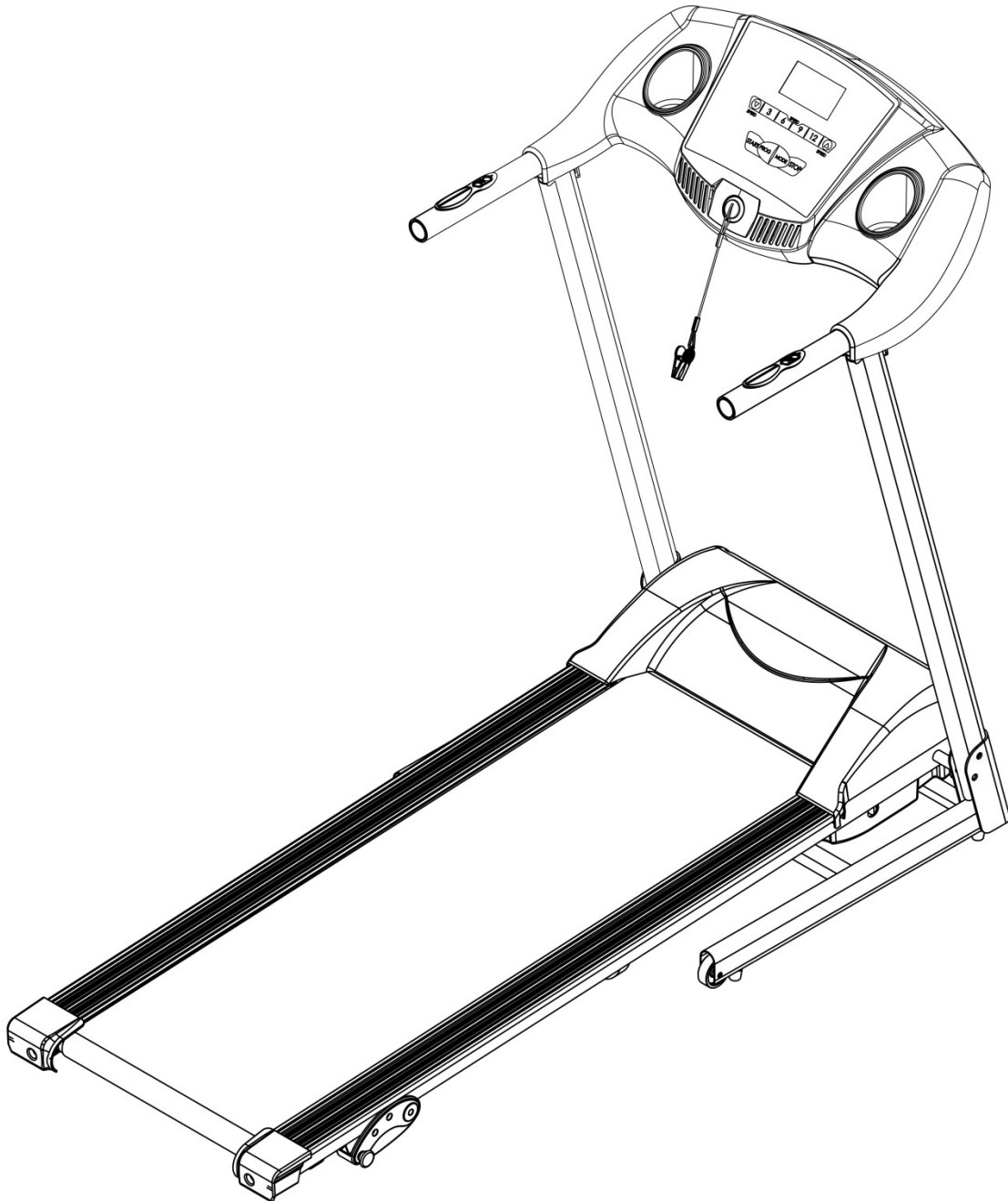

VISIT OUR BLOG FOR FITNESS TIPS,
HEALTH TIPS, AND MUCH MORE!

BLOG.LIFESPANFITNESS.COM.AU

FIT OWNER'S MANUAL



Product may vary slightly from the item pictured due to model upgrades

Read all instructions carefully before using this product. Retain this owner's manual for future reference.

TABLE OF CONTENTS

1.	IMPORTANT SAFETY INSTRUCTIONS	3
2.	IMPORTANT ELECTRICAL INFORMATION	4
3.	IMPORTANT OPERATING INSTRUCTIONS	5
4.	ASSEMBLY INSTRUCTIONS	6
5.	FOLDING INSTRUCTIONS	10
6.	OPERATION GUIDE WITH PROGRAM CHART	11
7.	EXERCISE GUIDE	16
8.	MAINTENANCE INSTRUCTIONS	18
9.	EXPLODED DIAGRAM	23
10.	PARTS LIST	24
11.	TROUBLE SHOOTING GUIDE	25
12.	WARRANTY	30

1. IMPORTANT SAFETY INSTRUCTIONS

WARNING - Read all instructions before using this treadmill.

It is important your treadmill receives regular maintenance to prolong its useful life. Failing to regularly maintain your treadmill may void your warranty.

Danger – To reduce the risk of electric shock disconnect your treadmill from the electrical outlet prior to cleaning and/or service work.

DO NOT USE AN EXTENSION CORD: DO NOT ATTEMPT TO DISABLE THE GROUNDED PLUG BY USING IMPROPER ADAPTERS OR IN ANY WAY MODIFY THE CORD SET.

- Install the treadmill on a flat level surface with access to a 220-240 volt (50/60Hz), grounded outlet.
- Do not operate treadmill on deeply padded, plush or shag carpet. Damage to both carpet and treadmill may result.
- Do not block the rear of the treadmill. Provide a minimum of 1 metre clearance between the rear of the treadmill and any fixed object.
- Place your unit on a solid, level surface when in use
- Never allow children on or near the treadmill.
- When running, make sure the plastic clip is fastened on your clothing. It is for your safety, should you fall or move too far back on the treadmill.
- Keep hands away from all moving parts.
- Never operate the treadmill if it has a damaged cord or plug.
- Keep the cord away from heated surfaces.
- Do not operate where aerosol spray products are being used or where oxygen is being administered. Sparks from the motor may ignite a highly gaseous environment.
- Never drop or insert any object into any openings.
- The treadmill is intended for in-home use only and not suitable for long time running.

- To disconnect, turn all controls to the off position, remove the safety key, and then remove the plug from the outlet.
- The pulse sensors are not medical devices. Various factors, including the user's movement, may affect the accuracy of heart rate readings. The pulse sensors are intended only as exercise aids in determining heart rate trends in general.
- Use the handrails provided; they are for your safety.
- Wear proper shoes. High heels, dress shoes, sandals or bare feet are not suitable for use on your treadmill. Quality athletic shoes are recommended to avoid leg fatigue.
- Allowed temperature: 5 to 40 degrees.

Remove the safety key after use to prevent unauthorized treadmill operation.

2. IMPORTANT ELECTRICAL INFORMATION

WARNING!

- NEVER use a ground fault circuit interrupt (GFCI) wall outlet with this treadmill. Route the power cord away from any moving part of the treadmill including the elevation mechanism and transport wheels.
- NEVER remove any cover without first disconnecting AC power.
- NEVER expose this treadmill to rain or moisture. This treadmill is not designed for use outdoors, near a pool, or in any other high humidity environment.
- This is high-power item; please do not share the same outlet with other high power machines such as, fridges, air conditioning etc. Please choose an outlet exclusively for the machine and make sure the fuse is 10A.

3. IMPORTANT OPERATING INSTRUCTIONS

- Be sure to read the entire manual before operating your machine.
- Understand that changes in speed and incline do not occur immediately. Set your desired speed on the computer console and release the adjustment key. The computer will obey the command gradually.
- Use caution while participating in other activities while walking on your treadmill, such as watching television, reading, etc. These distractions may cause you to lose balance or stray from walking in the centre of the belt; which may result in serious injury.
- In order to prevent losing balance and suffering unexpected injury, **NEVER** mount or dismount the treadmill while the belt is moving. This unit starts with at a very low speed. Simply standing on the belt during slow acceleration is proper after you have learned to operate this machine.
- Always hold on to handrail while making control changes.
- A safety key is provided with this machine. Remove the safety key will stop the walking belt immediately; the treadmill will shut off automatically. Inserting the safety key will reset the display.
- Do not use excessive pressure on console control keys. They are precision set to function properly with little finger pressure.

4. ASSEMBLY INSTRUCTIONS

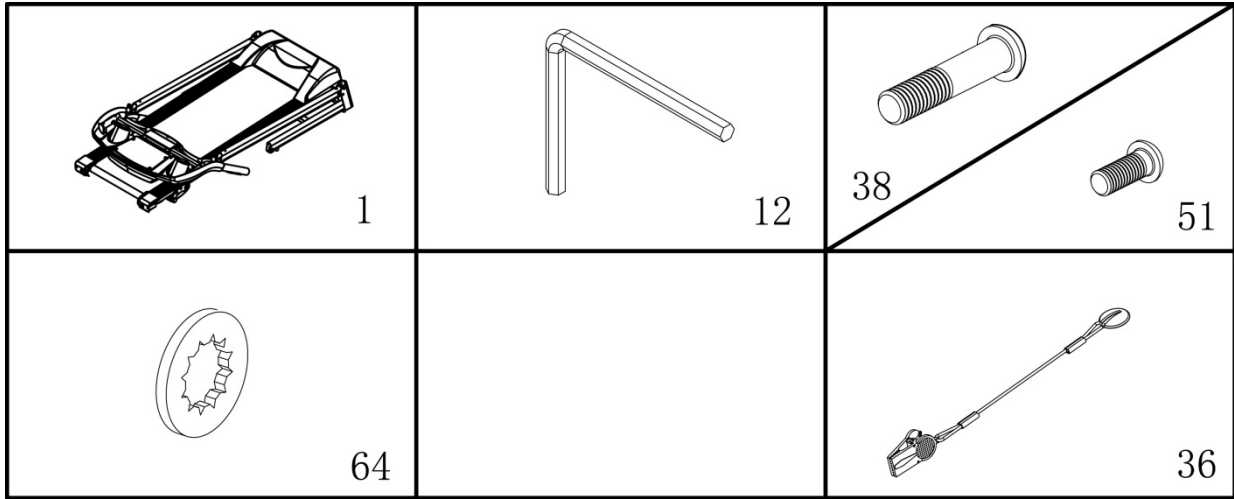

PART LIST

NO.	DISCRIPTION	SPECIFICATI ON	QT Y	NO.	DISCRIPTION	SPECIFICATION	QT Y
1	MAIN FRAME		1	64	LOCK WASHER	8	6
12	5#ALLEN WRENCH	5mm	1	36	SAFETY KEY		1
38	BOLT	M8*45	2				
51	BOLT	M8*16	4				

ASSEMBLY TOOLS:

5#Allen Wrench 5mm x 1pc

Note: Do not get through power before complete assembly

Note: Before installation. Please do not insert the power

STEP 1:

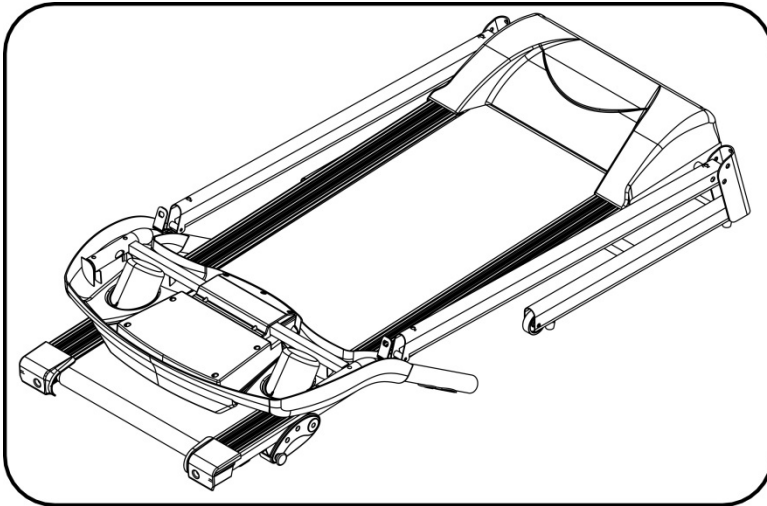

1. Open the carton
 2. Extract the parts listed above
 3. Place the Main Frame onto level ground
-

STEP 2:

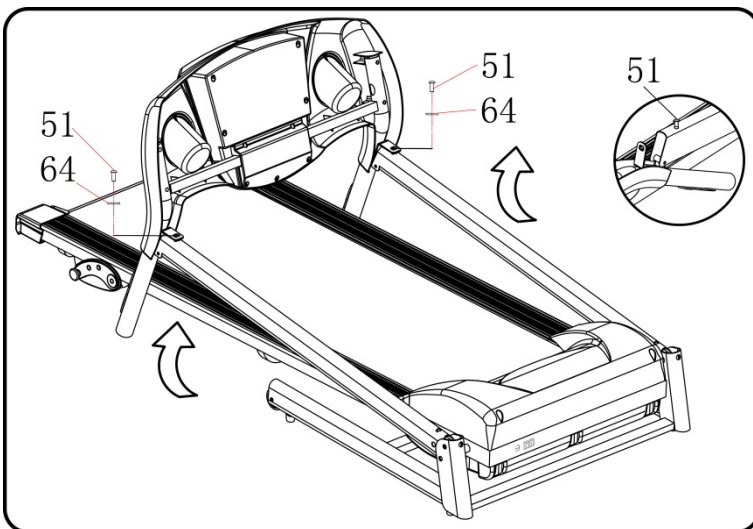

1. Position the computer according to the diagram.
2. While supporting the computer frame. Use the 5# Allen Wrench, screw through the Bolt (51) to Lock Washer (64), then secure the display onto left & right uprights

Note: Support the upright with your hands to avoid it falling down and causing injury.

STEP 3:

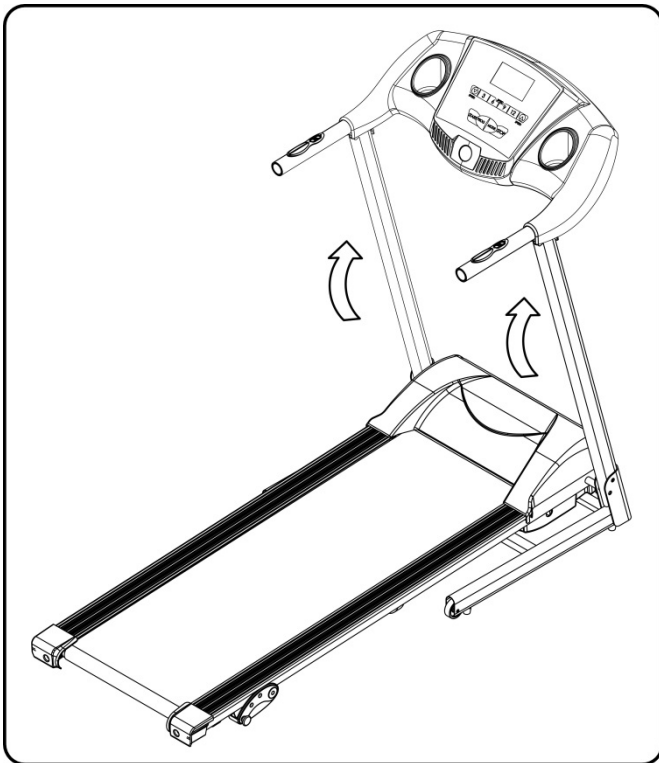

1. Erect the computer and the upright tubes

Support the upright with your to avoid the display falling and causing injury

STEP 4:

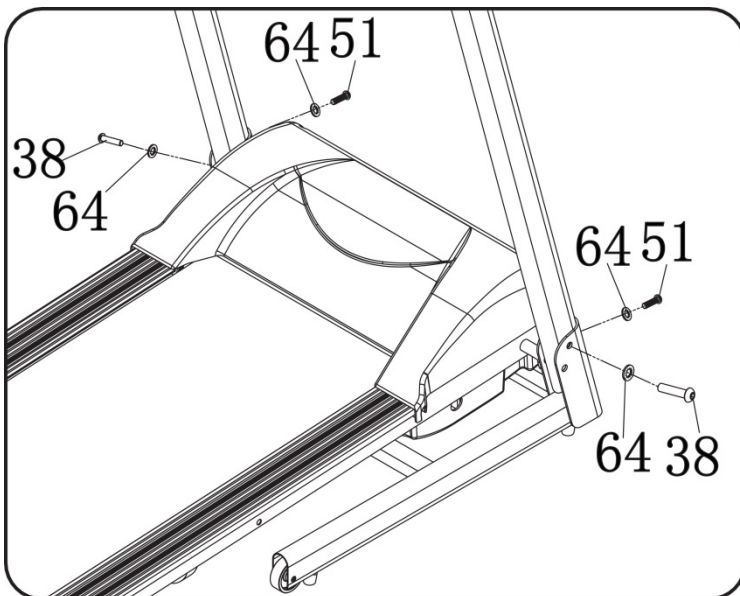

1. Using the 5# Allen wrench (12), insert the Bolt M8*45 (38) into the Lock washer (64). Then secure the Right Upright Tube to the Main Frame
2. Use the Bolt M8*16 (38) to secure Lock Washer (64). Then attach the Right Upright onto the base frame. Repeat this for the left side, see diagram.

STEP 5:

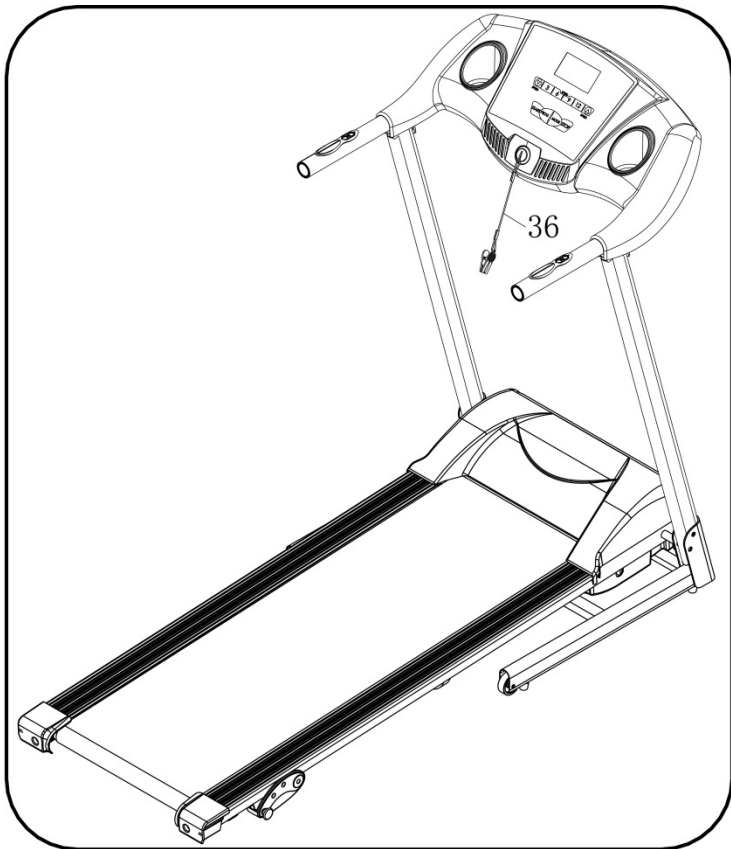

1. Place the safety key (36) into its dock on the display and switch the power switch on.

ATTENTION: Please double check assembly instructions and ensure that all nuts and bolts are secure and have been tightened correctly.

5. FOLDING INSTRUCTIONS

Unfolding:

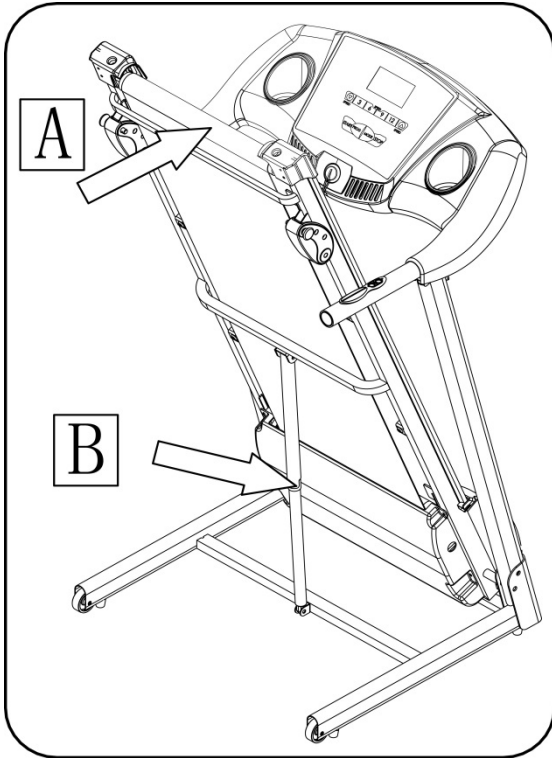

Whilst supporting position (A) with our hand, gently push position (B), the marked area on the air pressure bar, with your foot. The base frame will descend automatically. (Please keep people and any pets away the machine during descent)

Folding:

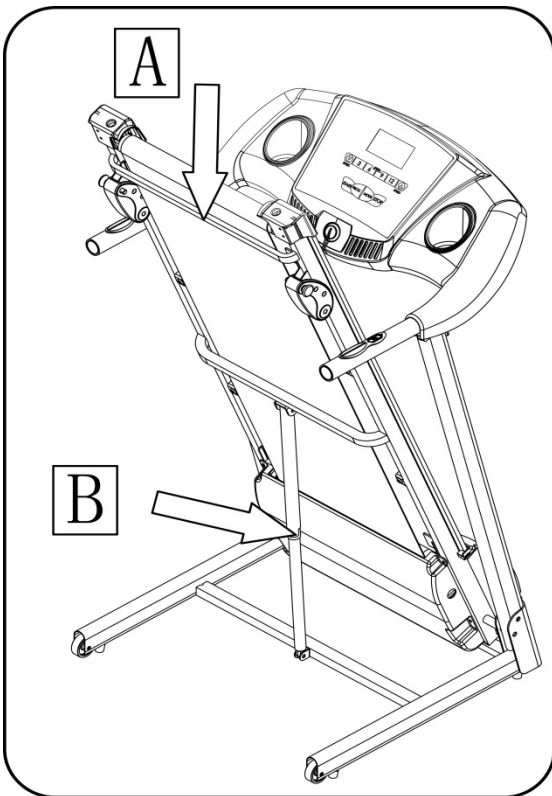

Place your hand on position (A), then pull up the base frame until you hear the click sound emitted when the air pressure bar (B) is locked into the round tube.

Video Tutorial Available at:
<http://youtu.be/TcuPbJ7KuxQ>

Lifespan Fitness YouTube Channel:
<http://www.youtube.com/user/treadmillsvideos>

6. OPERATION GUIDE WITH PROGRAM CHART

1. OVERVIEW

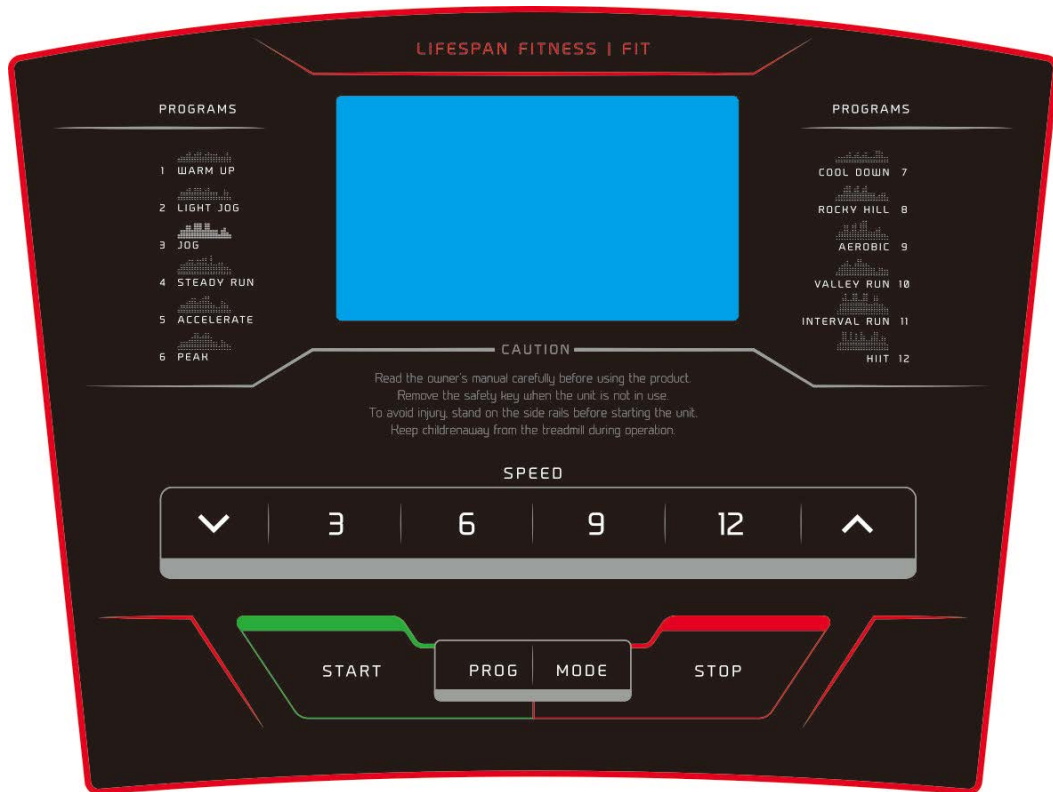

2. LCD WINDOW DISPLAY

1. **SPEED:** Shows speed.
2. **TIME window:** displays exercise time
3. **DIST/CAL window:** shows the running distance and calories burnt. Calories burnt are an estimate only.
This is not to be used as medical data.
4. **PROG:** displays program number
5. **PULSE:** shows heart rate. (Heart rate data is for reference ONLY.)

3. BUTTON FUNCTIONS

1. **“PROGRAM”**: choose the program, cycle between manual mode, P1 – P12 to FAT.
2. **“MODE”**: mode selection button. Press this button to cycle the mode.
 - a. During standby mode, MODE to choose between countdown mode, from TIME countdown, DISTANCE countdown and CALORIE countdown.
 - b. During BODY FAT mode, press this button to choose parameters SEX/AGE/HEIGHT/WEIGHT respectively
3. **“START”**: begins workout. When the power is on and safety key correctly placed on the computer, press this button to start the treadmill after a 3 second countdown.
4. **“STOP”**: press button to stop the motor running and to stop the machine
5. **SPEED+\SPEED-**: Increase or decrease speed when exercising. Sets parameters when stopped.
6. **“SPEED: 3,6,9,12”** Speed adjustment shortcut key

Left handle bar buttons: Start/Stop

Right handle bar buttons: adjusts speed

4. MAIN FUNCTIONS

4.1. Quick Start-up (Manual):

Attach the safety key. After a 3 second countdown, the treadmill will starting and running from the lowest speed, add and subtract to the speed using the SPEED +/- buttons.

4.2. Countdown mode:

Press the MODE button to cycle options: timer countdown, distance countdown, calories countdown. The default value corresponds to the window and flashing display. At this point the SPEED buttons serve as plus and minus functions to adjust to the desired value. Press the START, add and subtract speed by using SPEED buttons once again. When the countdown reaches 0, the machine will stop. You can also directly press the STOP button or disconnect the safety key to stop.

4.3. Preset programs:

Press the program button; programs from P1 to P12 are built-in programs. The time window displays the default value of TIME. When flashing, press the SPEED buttons to adjust to your desired time. Built-in program are divided into 20 equal segments. After pressing the START button, the treadmill will automatically cycle through the time segments. Speed will automatically adjust to the preset value for the segment. Upon completion of the segments, the program will end, slowing the treadmill down to a stop. During the operation speed can be adjusted but the next segment will be automatically adjusted to the program defaults. Built-in program data is listed on the Program Chart at end of this section.

4.4. Heart Rate:

When holding the hand pulse with two hands, the pulse window will show your heart rate after 5 seconds. To increase accuracy please check heart rate with the machine stopped and after keeping your hands on the sensors for more than 30 seconds.

The heart rate data is for reference purposes only and should not be used for medical purposes. See the end of this document for further detail.

4.5. Sleep function:

The treadmill automatically enters sleep mode after 10 minutes of inactivity. Press any key on the display to wake the treadmill.

4.6. Data display and set range:

	Show Range	Mode Default	Program Default	Setting Range
Speed	0.8KMH—14KMH	-----	-----	-----
Time	0:00—99:59	30:00	30:00	5:00---99:00
Distance	0.00KM—99.9KM	1.00KM	-----	0.5KM—99.5KM
Calorie	0Kcl—999Kcl	50Kcl	-----	10Kcl—995Kcl

4.7. Body Fat Test Function

1. Press the “PROGRAM” button under ready condition until the letters “FAT” show in the speed window. “FAT” is body fat test mode.
2. Press the “MODE” button to input data into parameters “SEX / AGE / HEIGHT / WEIGHT”. The “TIME/DIST” window will show “-1-”, “-2-”, “-3-”, “-4-“, which corresponds to “SEX / AGE / HEIGHT / WEIGHT” respectively. 01 is MALE, whilst 02 is FEMALE.
3. When setting each parameter, press SPEED ▲/▼ to adjust the data, and CAL/PULSE window will show the data. Press the “MODE” button to finish, and the window will show“-5-” and “-” then it will enter into ready condition. Hold the hand pulse sensors with both hands and it will show your BMI data after 5 seconds.

Body fat index table:

Parameter class	Default	Setting range	Remark
Sex	0 (Male)	0—1	0=Male 1= Female
Age	25 years	10—99 years	
Height	170 CM	100—240 CM	
Weight	70KG	20—160KG	

Body fat index compare table:

Bodyfat index (BMI)	Body status
<19	Underweight
19--26	Average
26--30	Overweight
>30	Obese

Program Chart

TIME		Total program time / 20 = running time of each segment																			
PROG		1	2	3	4	5	6	7	8	9	10	11	12	13	14	15	16	17	18	19	20
P1	SPEED	2	3	3	4	5	3	4	5	5	3	4	5	4	4	4	2	3	3	5	3
P2	SPEED	2	4	4	5	6	4	6	6	6	4	5	6	4	4	4	2	2	5	4	2
P3	SPEED	2	4	4	6	6	4	7	7	7	4	7	7	4	4	4	2	4	5	3	2
P4	SPEED	3	5	5	6	7	7	5	7	7	8	8	5	9	5	5	6	6	4	4	3
P5	SPEED	2	4	4	5	6	7	7	5	6	7	8	8	5	4	3	3	6	5	4	2
P6	SPEED	2	4	4	4	5	6	8	8	6	7	8	8	6	4	4	2	5	4	3	2
P7	SPEED	2	3	3	3	4	5	3	4	5	3	4	5	3	3	3	6	6	5	3	3
P8	SPEED	2	3	3	6	7	7	4	6	7	4	6	7	4	4	4	2	3	4	4	2
P9	SPEED	2	4	4	7	7	4	7	8	4	8	9	9	4	4	4	5	6	3	3	2
P10	SPEED	2	4	5	6	7	5	4	6	8	8	6	6	5	4	4	2	4	4	3	3
P11	SPEED	2	5	8	10	7	7	10	10	7	7	10	10	6	6	9	9	5	5	4	3
P12	SPEED	3	4	9	9	5	9	5	8	5	9	7	5	5	7	9	9	5	7	6	3

7. EXERCISE GUIDE

PLEASE NOTE: Before beginning any exercise program, consult your physician. This is important especially if you are over the age of 45 or individuals with pre-existing health problems.

The pulse sensors are not medical devices. Various factors, including the user's movement, may affect the accuracy of heart rate readings. The pulse sensors are intended only as an exercise aid in determining heart rate trends in general.

Exercising is great way to control your weight, improving your fitness and reduce the effect of aging and stress. The key to success is to make exercise a regular and enjoyable part of your everyday life.

The condition of your heart and lungs and how efficient they are in delivering oxygen via your blood to your muscles is an important factor to your fitness. Your muscles use this oxygen to provide enough energy for daily activity. This is called aerobic activity. When you are fit, your heart will not have to work so hard. It will pump a lot fewer times per minute, reducing the wear and tear of your heart.

So as you can see, the fitter you are, the healthier and greater you will feel.

Warm-up

Start each workout with 5 to 10 minutes of stretching and some light exercises. A proper warm-up increases your body temperature, heart rate and circulation in preparation for exercise. Ease into your exercise.

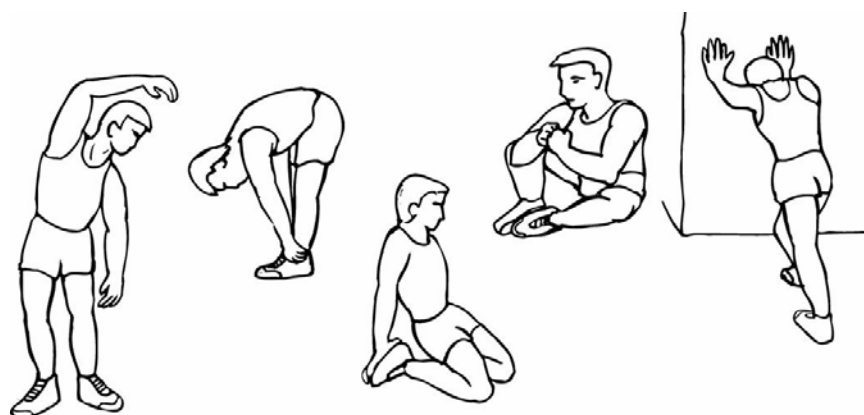

Training Zone Exercise

After warming up, increase the intensity to your desired exercise program. Be sure to maintain your intensity for maximum performance. Breathe regularly and deeply as you exercise-never hold your breath.

Cool Down

Finish each workout with a light jog or walk for at least 1 minute. Then complete 5 to 10 minutes of stretching to cool down. This will increase the flexibility of your muscles and will help prevent post-exercise problems.

Workout Guidelines

TARGET ZONE

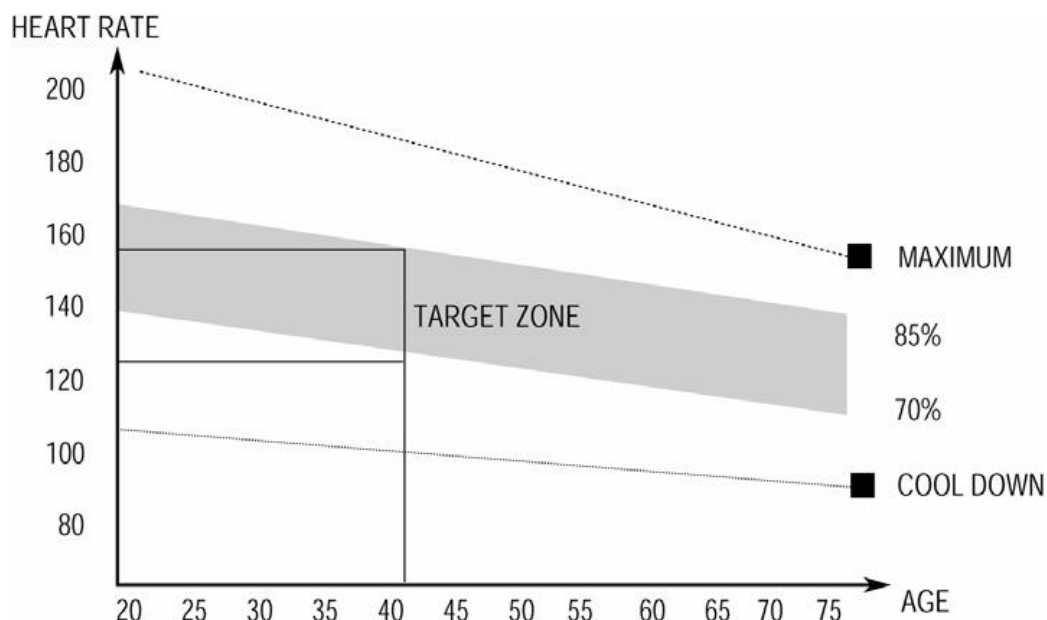

THIS IS HOW YOUR PULSE SHOULD BEHAVE DURING GENERAL FITNESS EXERCISE.

REMEMBER TO WARM UP AND COOL DOWN FOR A FEW MINUTES.

The most important factor here is the amount of effort you put in. The harder and longer you work, the more calories you will burn. Effectively this is the same as if you were training to improve your fitness, the difference is the goal.

8. MAINTENANCE INSTRUCTIONS

Reasonable cleaning/lubricating should be made to extend the life time of this unit. Performance is maximized when the belt and mat are kept as clean as possible.

WARNING: THE MAT/DECK FRICTION MAY PLAY A MAJOR ROLE IN THE FUNCTION AND LIFE OF YOUR TREADMILL AND THAT IS WHY WE RECOMMEND YOU CONSTANTLY LUBRICATE THIS FRICTION POINT TO PROLONG THE USEFUL LIFE OF YOUR TREADMILL. FAILING TO DO THIS MAY VOID YOUR WARRANTY.

WARNING: UNPLUG POWER CORD BEFORE MAINTENANCE

WARNING: STOP TREADMILL BEFORE FOLDING

1. General Cleaning

- Use a soft, damp cloth to wipe the edge of the belt and the area between the belt edge and frame. A mild soap and water solution along with a nylon scrub brush will clean the top of the textured belt. This task should be done once a month. Allow to dry before using.
- On a monthly basis, vacuum underneath your treadmill to prevent dust build up. Once a year, you should remove the black motor shield and vacuum out dirt that may accumulate.

2. General Care

- Check parts for wear before use.
- Pay particular attention to the fixing knobs and make sure they are tight.
- Always replace the mat if worn and any other defective parts.

- If in doubt do not use the treadmill and contact us.

TAKE CARE TO PROTECT CARPETS AND FLOOR in case of leakages. This product is a machine that contains moving parts which have been greased / lubricated and could leak.

3. Belt/Deck/Roller Lubrication

The mat/deck friction may play a major role in the function and life of your treadmill and that is why we recommend you constantly lubricate this friction point to prolong the useful life of your treadmill. You should apply lubrication after approximately the first 30 hours of operation. We recommend lubrication of the deck according to the following timetable:

- Light use (less than 3 hours per week) every 6 months
- Medium use (3-5 hours a week) every 3 months
- Heavy use (more than 5 hours per week) every 6-8 weeks

See below procedures for lubricating:

1. Use a soft, dry cloth to wipe the area between the belt and deck.
2. Spread lubricant onto the inside surface of belt and deck evenly (make sure the machine is turned off and power is disconnected).

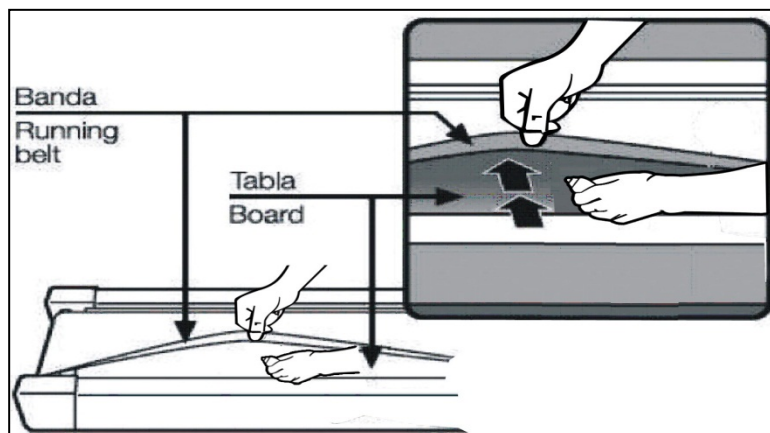

3. Periodically lubricate the front and rear rollers to keep them at their peak performance. If the treadmill belt/deck/roller is kept reasonably clean it is possible to expect over 1200 hours before relubricating is necessary.

Video Tutorial Available at:
<http://youtu.be/cP9NtFHfWlc>

Lifespan Fitness Channel:
<http://www.youtube.com/user/treadmillsvideos>

4. How to check the running mat for proper lubrication:

1. Disconnect the main power supply.
2. Fold the treadmill up into the storage position.
3. Feel the underside surface of the running mat.

If the surface is slick when touched, then no further lubrication is needed.

If the surface is dry to the touch, apply a suitable silicone lubricant.

We recommend that you use a silicone based spray to lubricate your Lifespan treadmill. This can be purchased directly from us or any hardware store.

5. Adjusting the Running Belt

Place treadmill on a level surface. Run treadmill at approximately 4km/h, checking the running condition.

If the belt has drifted to the **right**:

Whilst the treadmill is running at 4km/h, carefully turn the **right** adjusting bolt 1/4 turn **clockwise**. Then monitor treadmill until the belt centers. Repeat until the belt correctly centers.

See *Picture A*

If you have over adjusted the belt and it drifts to the right, carefully turn the **right** adjusting bolt **anticlockwise** until the belt centers.

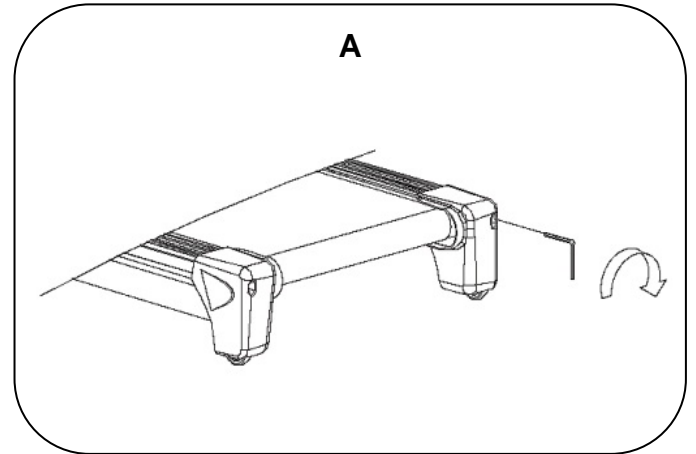

If the belt has drifted to the **left**:

Whilst the treadmill is running at 4km/h, carefully turn the **left** adjusting bolt 1/4 turn **clockwise**. Then monitor treadmill until the belt centers. Repeat until the belt correctly centers.

See *Picture B*

If you have over adjusted it, carefully turn the **left** adjusting bolt **anticlockwise** and until the belt centers.

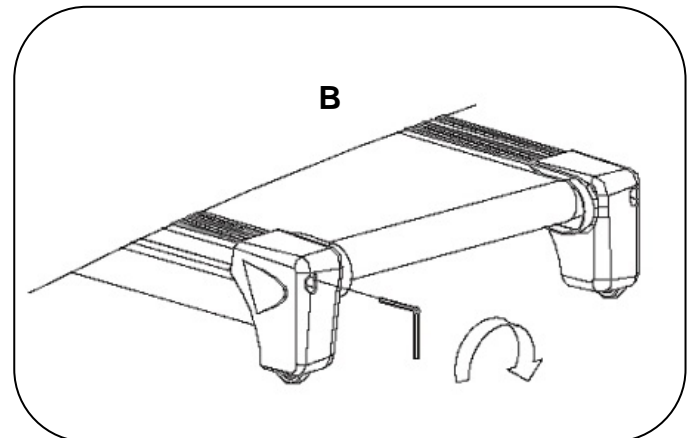

To adjust the **tightness** of the belt:

Turn the treadmill off. Turn both the left and right adjusting bolts 1/4 turn clockwise. Repeat until the belt correctly tightens.

See *Picture C*

If the belt is over tightened, simply do the opposite to loosen.

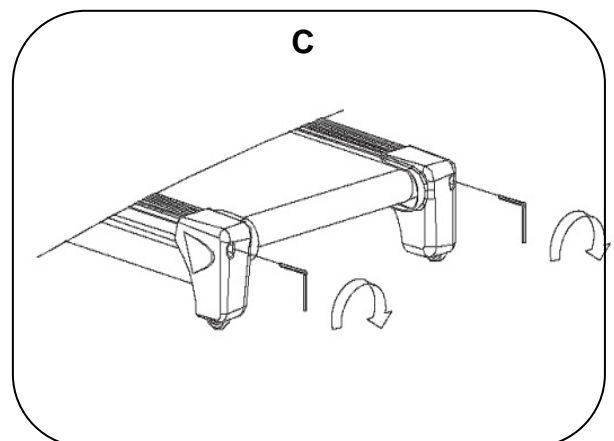

NOTE: When properly tightened, you should be able to peel the very edge of the side of the belt up approximately 2 inches. However this is a rough reference and not all treadmills are the same. Some treadmills that have longer belts may give different measurements for correct belt tightness.

Simply, if the belt begins to slip during use, this is an indication that the belt still needs tightening.

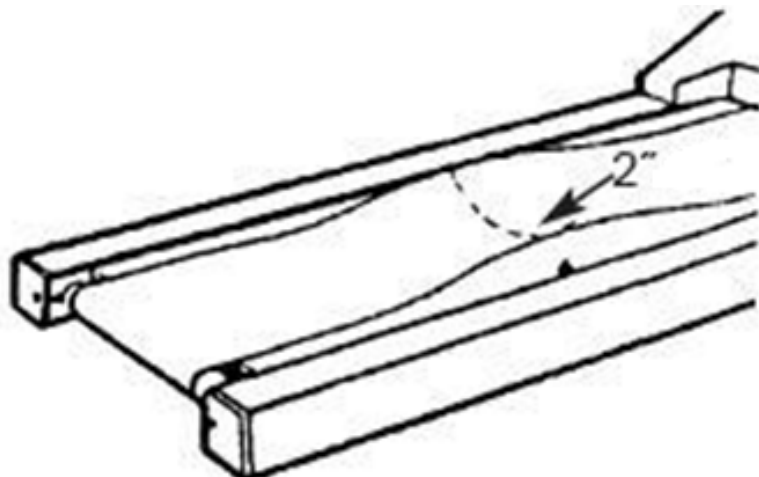

Video Tutorial Available at:
<http://youtu.be/vllsamTSvA>

Lifespan Fitness Channel:
<http://www.youtube.com/user/treadmillsvideos>

9. EXPLODED DIAGRAM

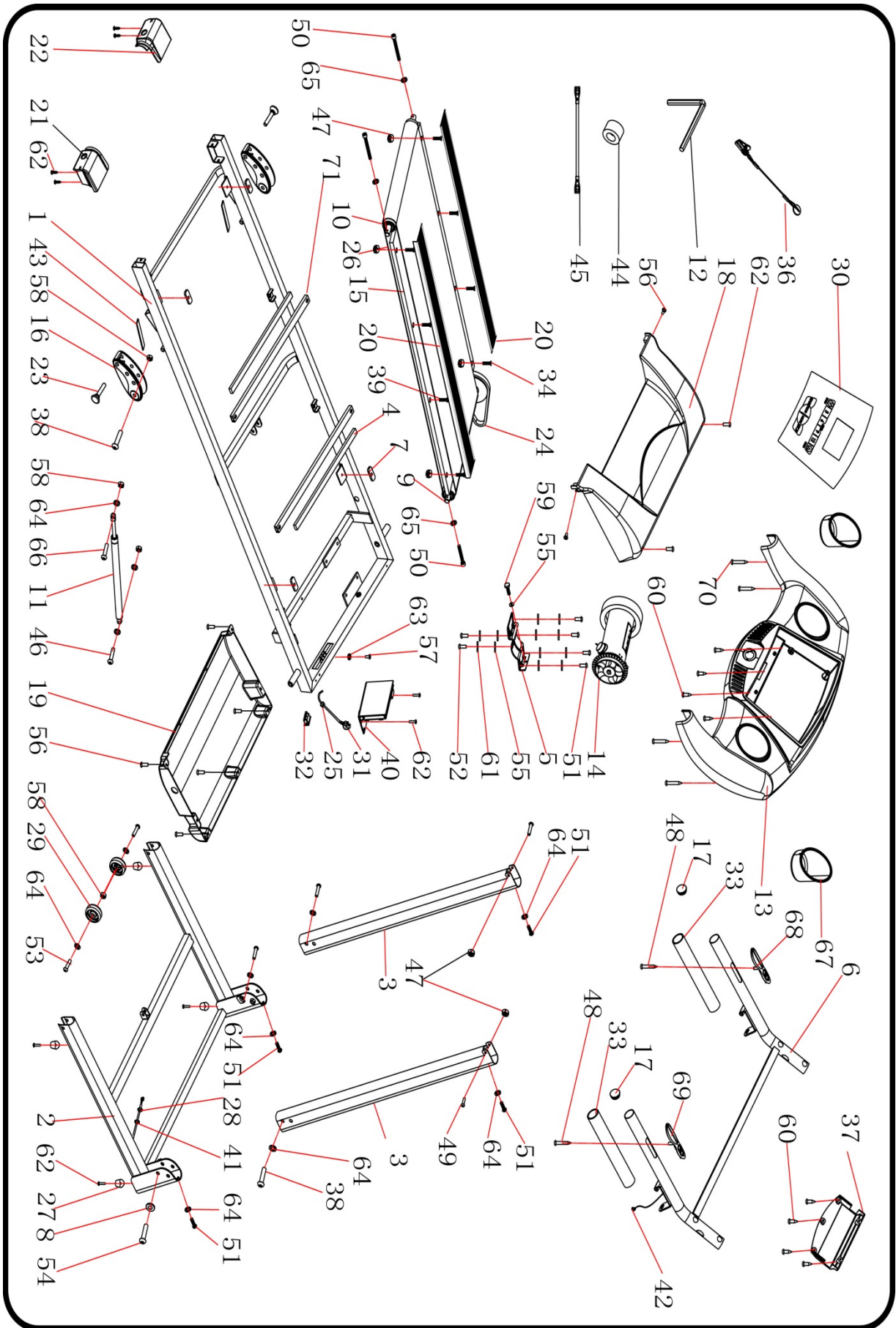

10. PARTS LIST

NO.	DISCRIPTION	SPECS	QTY.	NO.	DISCRIPTION	SPECS	QTY.
1	MAIN FRAME		1	37	Computer boards		1
2	BASE FRAME		1	38	Bolt	M8*45	4
3	Upright bracket		2	39	Bolt	M6*30	4
4	EVA cushion	400*20*5	2	40	Control Board		1
5	MOTOR BRACKET		1	41	Computer bottom wire		1
6	COMPUTER BRACKET		1	42	COMPUTER UP wire		1
7	rubber pad		4	43	Rubber pad		2
8	Lock washer	10	2	44	magnet ring		1
9	FRONT ROLLER		1	45	blue single lateral		1
10	REAR ROLLER		1	46	Bolt	M8*25	1
11	CYLINDER		1	47	screw	M6	6
12	5#ALLEN WRENCH	5mm	1	48	Bolt	ST4.2*28	2
13	Computer up cover		1	49	Bolt	M6*37	2
14	DC Motor		1	50	Bolt	M6*65	3
15	Running Board		1	51	Bolt	M8*16	8
16	Adjustable foot pad		2	52	Bolt	M8*12	2
17	Circle end cap		2	53	Bolt	M8*40	2
18	MOTOR TOP COVER		1	54	Bolt	M10*55	2
19	MOTOR BOTTOM COVER		1	55	Lock washer	8	7
20	Side rail		2	56	Bolt	ST4.2*12	7
21	RIGHT BACK COVER		1	57	Bolt	M5*8	5
22	LEFT BACK COVER		1	58	1 Screw	M8	6
23	fixed plug		2	59	Hexagon head bolts-- Product grade	M8*25	1
24	Motor belt		1	60	Bolt	ST4.2*13	9
25	POWER WIRE BUCKLE		1	61	Lock washer	8	6
26	Running belt		1	62	Bolt	ST4.2*19	12
27	Foot pad		4	63	Lock washer	5	1
28	ring wire plug B		2	64	Lock washer	8	12
29	transport wheel		2	65	Lock washer	6	3
30	Sticker		1	66	Bolt	M8*42	1
31	Stand Power wire		1	67	Water base		2
32	switch		1	68	Start/stop button		1
33	foam		2	69	Speed + -button		1
34	Bolt	M6*25	4	70	Bolt	ST4.2*20	4
				71	Running board strengthen tube		2
36	Safety key		1				

11. TROUBLE SHOOTING GUIDE

Fault Code	Main reason	Solution
E01	The wire from the display to bottom control board is not connected well	<ol style="list-style-type: none"> 1. Check the connection wire between computer and control board. 2. Make sure the IC on the control board is properly connected. If not re-connect. 3. Abnormal power supply in control board. Replace control board.
E02	Explosion protection	<ol style="list-style-type: none"> 1. Bad contact with motor open circuit. Replace motor or check the connector. 2. Power tube has been punctured. Replace Power tube or control board.
E05	Over current Protection	<ol style="list-style-type: none"> 1. Overloaded 2. Running board experiencing heavy resistance. Need to be oiled 3. Damage to Motor. Replace motor.
E06	Control board self-checking	
E08	EEPROM damage	Replace the control board

12. WARRANTY

AUSTRALIAN CONSUMER LAW

Many of our products come with a guarantee or warranty from the manufacturer. In addition, they come with guarantees that cannot be excluded under the Australian Consumer Law. You are entitled to a replacement or refund for a major failure and compensation for any other reasonably foreseeable loss or damage.

You are entitled to have the goods repaired or replaced if the goods fail to be of acceptable quality and the failure does not amount to a major failure. Full details of your consumer rights may be found at www.consumerlaw.gov.au

Please visit our website to view our full warranty terms and conditions:

<http://www.lifespanonline.com.au/Warranty-Policy>

Please email us through support@lifespanfitness.com.au for all warranty or support issues.

Hand Pulse Technology

Lifespan Fitness Treadmills come equipped with hand pulse sensors which are used to pick up tiny EKG/ECG signals that run through the body when your heart beats. These electrical EKG/ECG signals are very small and that they must be amplified 1000 times to make the signal useful for the computer to display your pulse.

To ensure proper operation:

- The user must maintain good, consistent contact on all four sensors
- The users skin cannot be too dry or too wet

Other factors that could affect the reading:

- Change of grip on the sensors (during slow pace walking and up to running)
- Tightening of hand muscles will produce small electrical signals
- Static electricity charges from the air or from walking on the treadmill

EKG/ECG Sensors may filter through actual EKG/ECG signals and “Noise” factors that may affect the reading. This will cause the pulse reading to be delayed and will take longer to update the display as the heart rate changes. Too much noise will create an incorrect reading. Medical conditions or having no electrical signal in the hands are other factors that may affect pulse readings as well.

These are limitations of hand pulse technology and even the most expensive systems (which can cost upwards of \$3,000) used in hospitals have the same problems. The difference is that a patient in a hospital is not running on a treadmill. Hand pulse technology works well on stationary exercise machines like bikes and even elliptical cross trainers but are not perfect on a treadmill. We offer treadmills with a wireless heart rate receiver which may be a more accurate option.

To test if your hand pulse sensors are working up to specification, hold them while standing on the side step rails, not walking, and see if the reading is more in line with what you would expect. This will eliminate the movement and static electricity factors. If your hands are dry, then wet them slightly (saliva works as a great conductor if this doesn't bother you).

For more information, please contact our Lifespan Technical Support Department

www.lifespanfitness.com.au

support@lifespanfitness.com.au