

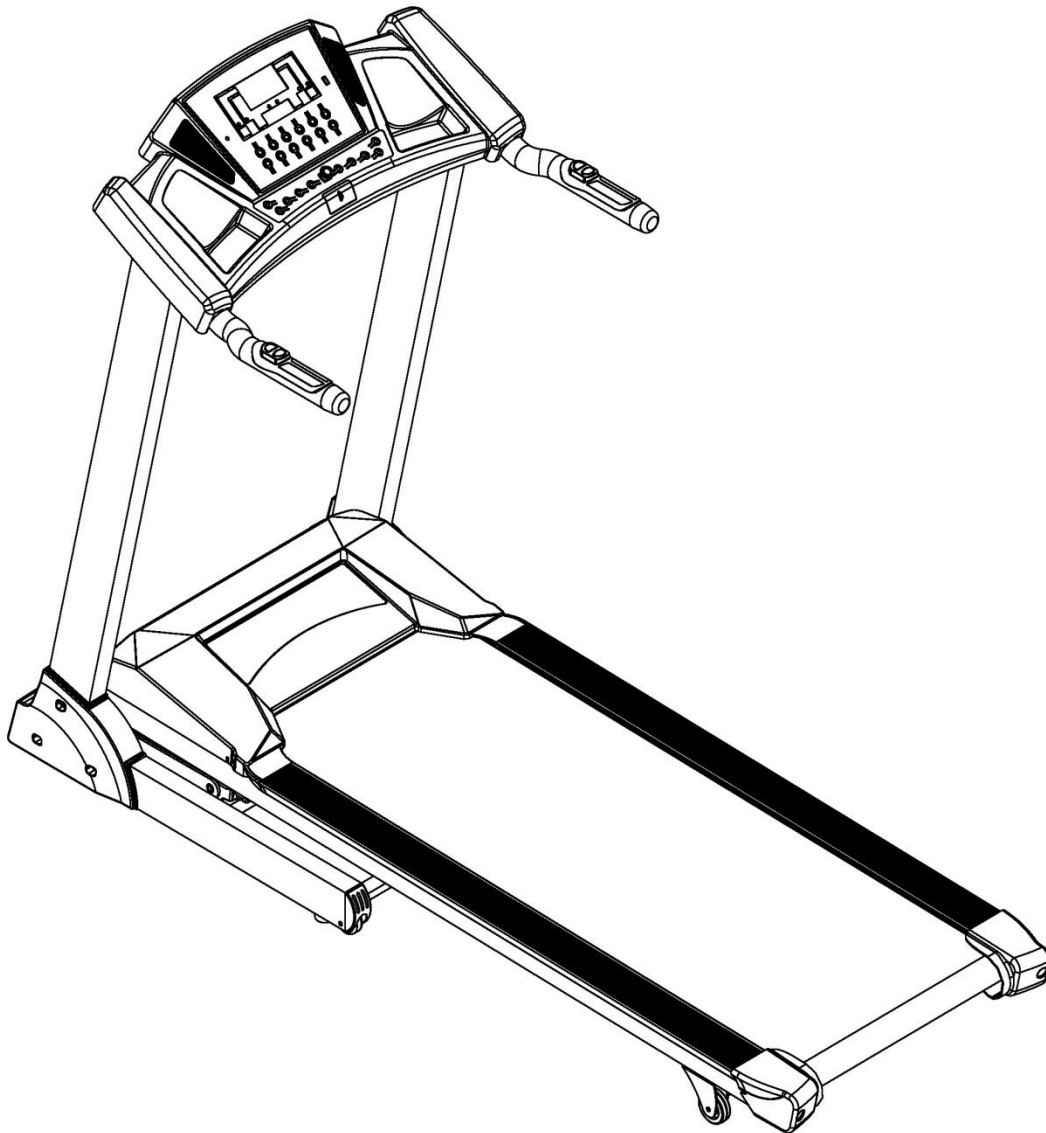

## FLITE OWNER'S MANUAL



Product may vary slightly from the item pictured due to model upgrades

Read all instructions carefully before using this product. Retain this owner's manual for future reference.

# TABLE OF CONTENTS

1.	IMPORTANT SAFETY INSTRUCTIONS_____	3
2.	IMPORTANT ELECTRICAL INFORMATION_____	4
3.	IMPORTANT OPERATING INSTRUCTIONS_____	5
4.	ASSEMBLY INSTRUCTIONS_____	6
5.	FOLDING INSTRUCTIONS_____	10
6.	GROUNDING METHODS_____	11
7.	OPERATION GUIDE_____	12
8.	EXERCISE GUIDE_____	17
9.	MAINTENANCE INSTRUCTIONS_____	19
10.	EXPLODED DIAGRAM_____	23
11.	PARTS LIST_____	24
12.	TROUBLE SHOOTING GUIDE_____	26
13.	WARRANTY_____	28
14.	PROGRAM GUIDE_____	29

# 1. IMPORTANT SAFETY INSTRUCTIONS

**WARNING** - Read all instructions before using this treadmill.

It is important your treadmill receives regular maintenance to prolong its useful life. Failing to regularly maintain your treadmill may void your warranty.

**Danger** – To reduce the risk of electric shock disconnect your treadmill from the electrical outlet prior to cleaning and/or service work.

DO NOT USE AN EXTENSION CORD: DO NOT ATTEMPT TO DISABLE THE GROUNDED PLUG BY USING IMPROPER ADAPTERS OR IN ANY WAY MODIFY THE CORD SET.

- Install the treadmill on a flat level surface with access to a 220-240 volt (50/60Hz), grounded outlet.
- Do not operate treadmill on deeply padded, plush or shag carpet. Damage to both carpet and treadmill may result.
- Do not block the rear of the treadmill. Provide a minimum of 1 metre clearance between the rear of the treadmill and any fixed object.
- Place your unit on a solid, level surface when in use
- Never allow children on or near the treadmill.
- When running, make sure the plastic clip is fastened on your clothing. It is for your safety, should you fall or move too far back on the treadmill.
- Keep hands away from all moving parts.
- Never operate the treadmill if it has a damaged cord or plug.
- Keep the cord away from heated surfaces.
- Do not operate where aerosol spray products are being used or where oxygen is being administered. Sparks from the motor may ignite a highly gaseous environment.
- Never drop or insert any object into any openings.
- The treadmill is intended for in-home use only and not suitable for long time running.

- To disconnect, turn all controls to the off position, remove the safety key, and then remove the plug from the outlet.
- The pulse sensors are not medical devices. Various factors, including the user's movement, may affect the accuracy of heart rate readings. The pulse sensors are intended only as exercise aids in determining heart rate trends in general.
- Use the handrails provided; they are for your safety.
- Wear proper shoes. High heels, dress shoes, sandals or bare feet are not suitable for use on your treadmill. Quality athletic shoes are recommended to avoid leg fatigue.
- Allowed temperature: 5 to 40 degrees.

Remove the safety key after use to prevent unauthorized treadmill operation.

## 2. IMPORTANT ELECTRICAL INFORMATION

### WARNING!

- NEVER use a ground fault circuit interrupt (GFCI) wall outlet with this treadmill. Route the power cord away from any moving part of the treadmill including the elevation mechanism and transport wheels.
- NEVER remove any cover without first disconnecting AC power.
- NEVER expose this treadmill to rain or moisture. This treadmill is not designed for use outdoors, near a pool, or in any other high humidity environment.

### 3. IMPORTANT OPERATING INSTRUCTIONS

- Be sure to read the entire manual before operating your machine.
- Understand that changes in speed and incline do not occur immediately. Set your desired speed on the computer console and release the adjustment key. The computer will obey the command gradually.
- Use caution while participating in other activities while walking on your treadmill, such as watching television, reading, etc. These distractions may cause you to lose balance or stray from walking in the centre of the belt; which may result in serious injury.
- In order to prevent losing balance and suffering unexpected injury, **NEVER** mount or dismount the treadmill while the belt is moving. This unit starts with at a very low speed. Simply standing on the belt during slow acceleration is proper after you have learned to operate this machine.
- Always hold on to handrail while making control changes.
- A safety key is provided with this machine. Remove the safety key will stop the walking belt immediately; the treadmill will shut off automatically. Inserting the safety key will reset the display.
- Do not use excessive pressure on console control keys. They are precision set to function properly with little finger pressure.

## 4. ASSEMBLY INSTRUCTIONS

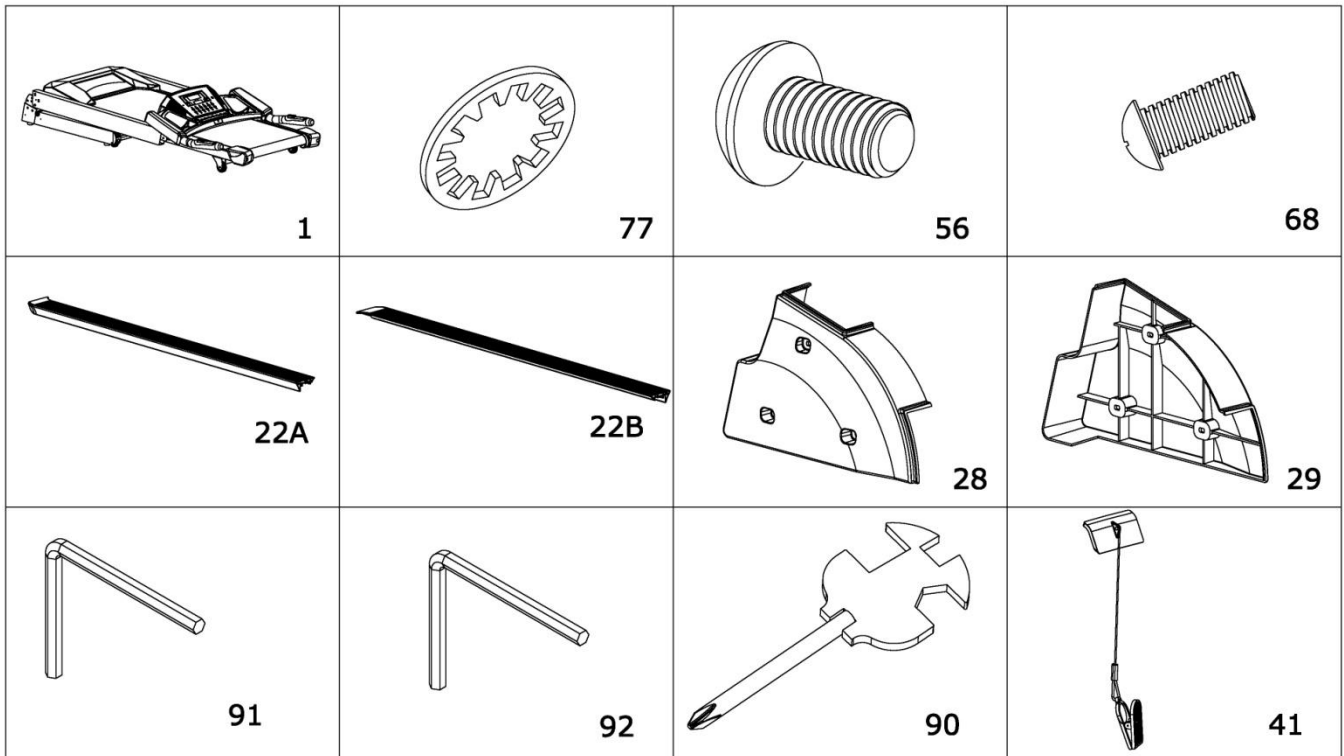

### PART LIST

NO.	DES.	Specification	Nos.	NO.	DES.	Specification	Nos.
1	Main Frame		1	28	Left Upright Tube Cover		1
77	Lock Washer	10	10	29	Right Upright Tube Cover		1
56	Bolt	M10*12	10	91	5# Allen Wrench	5mm	1
68	Bolt	M5*8	6	92	6# Allen Wrench	6mm	1
22A	Left Side Rail		1	90	Wrench w/screw Driver	S=13、 14、 15	1
22B	Right Side Rail		1	41	Safety key		1

### STEP 1:

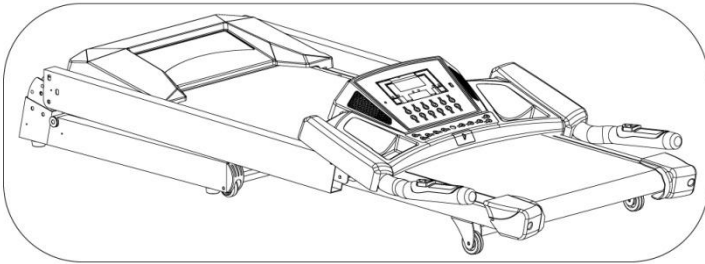

1. Open the carton
  2. Extract the parts listed above
  3. Place the Main Frame (1) onto level ground
- 

### STEP 2:



1. Raise the Computer and Upright tubes in the direction of the arrows.

*Note: Whilst erecting the uprights, make sure the upright does not press against and damage the wires inside the upright tubes. Keep holding the upright and computer by hand so they do not fall down and cause injury*

---

### STEP 3:

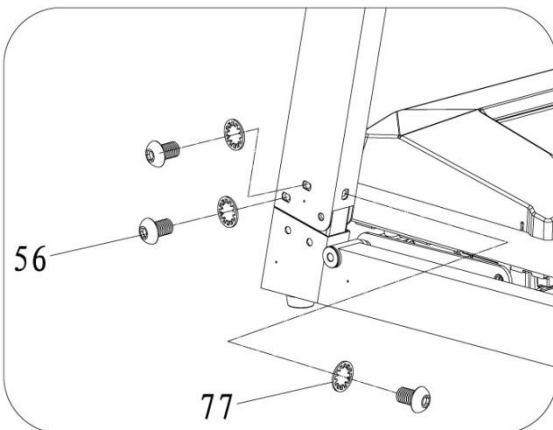

1. Using the 6# Allen wrench, screw through the bolt (56) M10\*15 to Lock washer (77), then lock the Left upright tube onto MAIN FRAME.

*Note: Support the Uprights with your hands to prevent them falling down and causing injury.*

---

**STEP 4:**

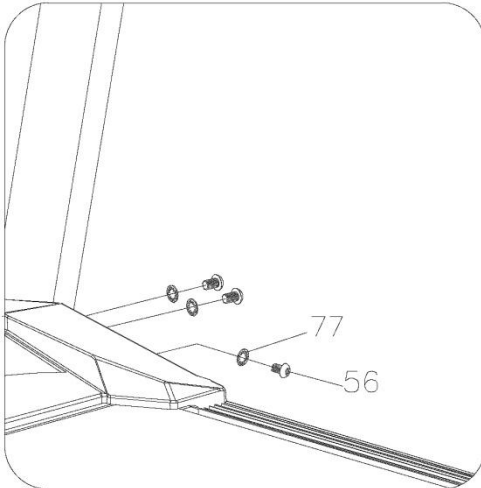

1. Using the 6# Allen wrench, screw through the bolt (56) M10\*15 to Lock washer (77), then lock the Right upright tube onto MAIN FRAME.

*Note: Support the Computer with your hands to prevent it falling down and causing injury.*

**STEP 5:**

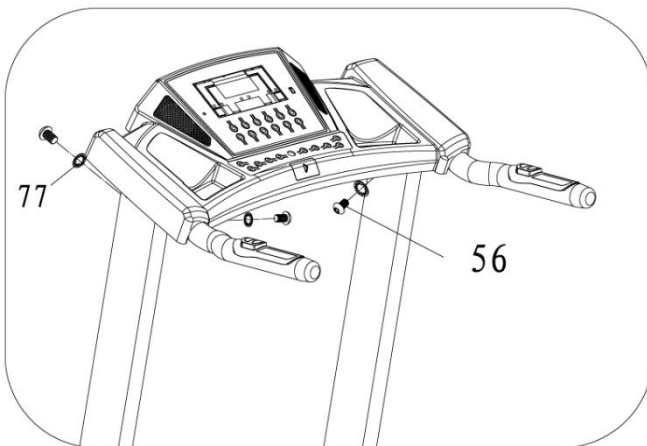

1. Use the 6# Allen wrench, screw through the bolt (56) M10\*15 to Lock washer (77), then lock the COMPUTER (64) onto R&L upright tubes.

**STEP 6:**

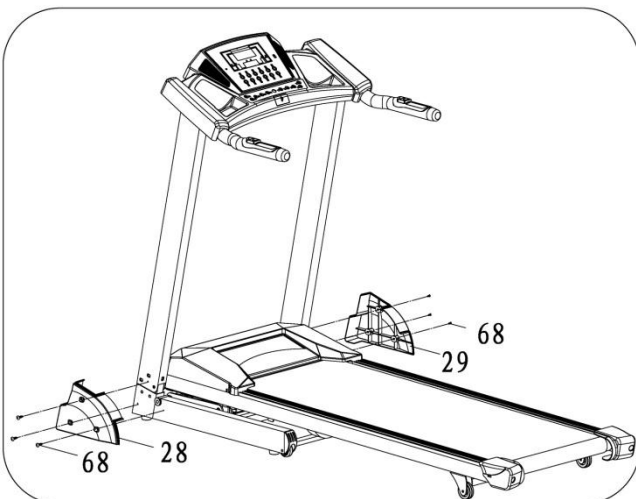

1. Lock the left upright tube cover (28) and right upright tube cover (29) onto the base frame with screw (68) M5\*8



**STEP 6:**

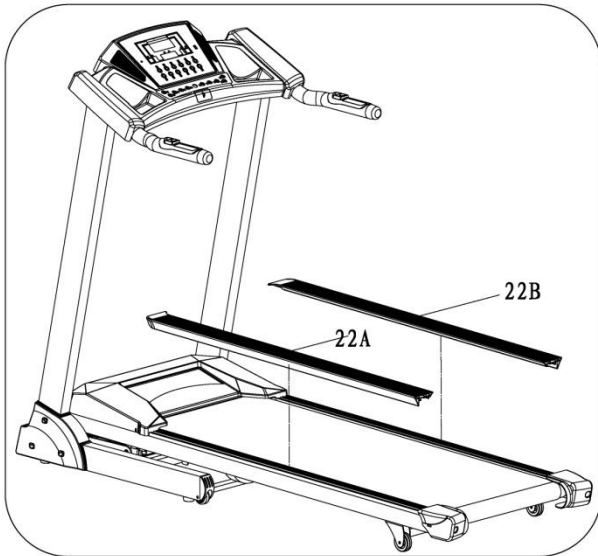

1. Press the Left Side Rail (22A) and Right Side Rail (22B) onto the Running Board along the inner side rail.

Note: Before assembling the side rail, please check the back end cover (15 and 16), loosen the bolt (68) on the back end cover, and then pull back the cover. After assembly, pull forward the cover, and tighten the bolt

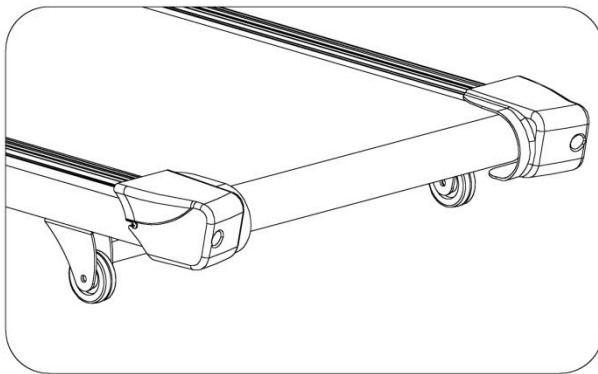

## 5. FOLDING INSTRUCTIONS

### Folding:

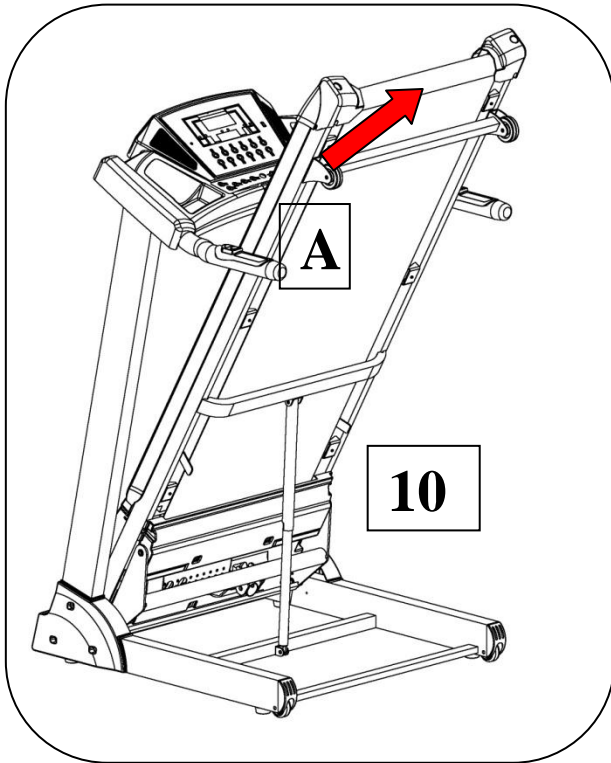

Support position A with your hand, then pull up the running board following the arrow direction until you hear a clicking sound of the cylinder (10) locking into the round tube.

### Unfolding:

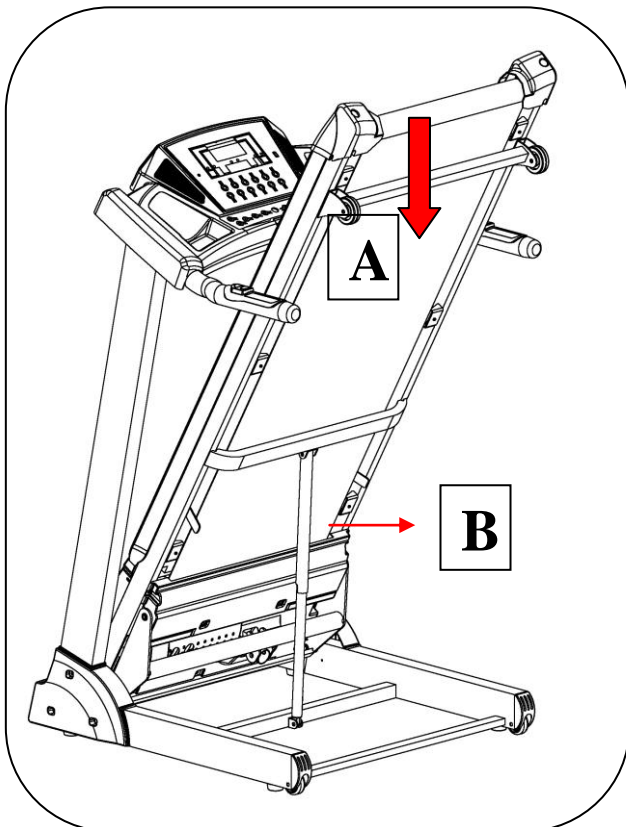

Support position A with your hand, depress position B of the air pressure control bar, then the base frame will descend automatically

## 6. GROUNDING METHODS

This product must be grounded. In the event of malfunction or breakdown, grounding reduces the risk of electric shock. This product is equipped with a cord with an equipment-grounding conductor and a grounding plug. The plug must be plugged into an appropriate outlet that is properly installed and grounded in accordance with all local codes and ordinances.

### DANGER

Improper connection of the equipment-grounding conductor can result in risk of electric shock.

Check with a qualified electrician or serviceman if you are in doubt as to whether the product is properly grounded.

Do not modify the plug provided with the product – if it will not fit the outlet; have a proper outlet installed by a qualified electrician.

This product is for use on a nominal 240-volt circuit and has a grounding plug that looks like the plug illustrated in sketch A in following figure. Ensure the product is connected to an outlet having the same configuration as the plug. No adapter should be used with this product.

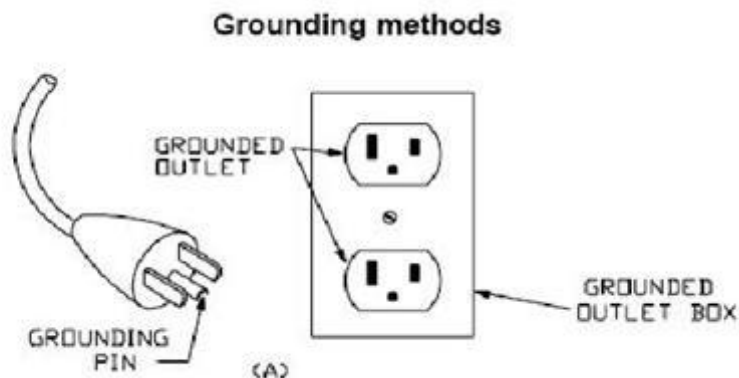

# 7. OPERATION GUIDE

## 1. OVERVIEW

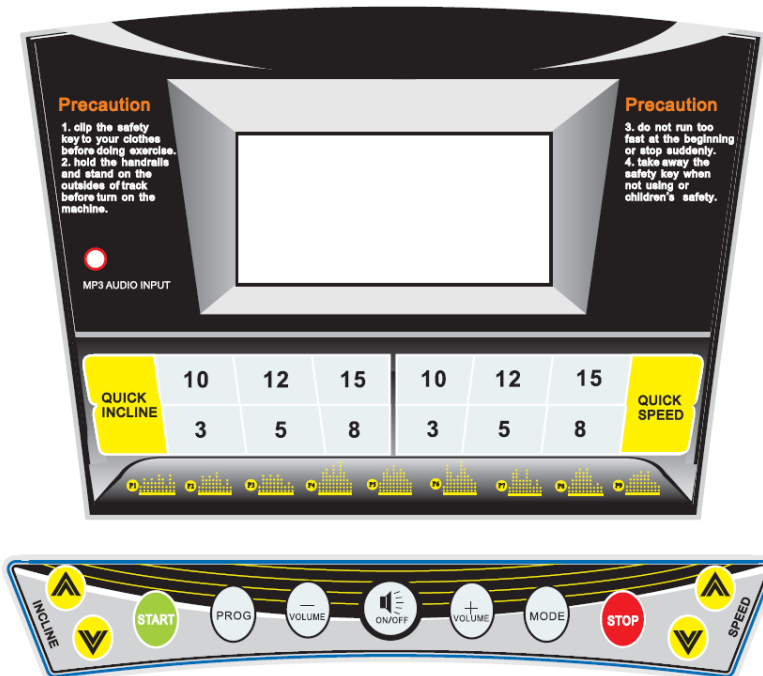

## 2. LCD WINDOW DISPLAY

1. **Speed window:** displays “P1-P15-U1-U3-FAT” when setting mode. The speed range is 1-22km/h during workout.
2. **Incline window:** displays incline gradient, the range is 0-20.
3. **Time window:** displays workout time, the range is 0:00-99:59. When time reaches 99:59, the treadmill will slow down until stop and show “End”. 0.5 seconds after “End” the treadmill will enter standby. The Countdown setting is from the setting time until the timer reaches zero. Upon reaching “0”, the computer will display “End” and will slow down to a stop. Then it will enter standby in 5 seconds
4. **DIS window:** shows the running distance. The range is from 0.00-99.9km. When distance reaches 99.9, the treadmill will slow down until stop and show “End”. Upon reaching “0”, the computer will display “End” and will slow down to a stop. Then it will enter standby in 5 seconds
5. **PUL/CAL window:** shows the heart rate and calories burnt. When displaying calorie value the range is from 0-999. When it reaches 999 the treadmill will slow down until a stop and show “End”. Countdown is from the setting value to zero. Upon reaching “0”, the computer will display “End” and will slow down

to a stop. Then it will enter standby in 5 seconds. When you hold the hand pulse sensor the window will show your heart rate. The range is from 50-200 beats per minute (Heart rate data is for reference ONLY.)

### 3. BUTTON FUNCTIONS

1. **"PROG"**: when the treadmill is in standby mode, this button cycles through: "0:00", "P1-P99", "U1-U3", "FAT".
  - a. "0:00" is the manual mode and default running mode.
  - b. "P1-P99" are built in programs
  - c. "U1-U3" are user defined programs
  - d. "FAT" is body fat test mode
2. **"MODE"**: mode selection button. Press this button to cycle through "0:00", "15:00", "1.0", "50"
  - a. ("0:00" = manual mode, "15:00" = timer countdown mode, "1.0" = distance countdown mode, "50" = calorie countdown mode)
  - b. You can adjust the value with the Speed+ & Speed- or INCL+ & INCL- buttons. Press "START" to start your exercise after finishing setting the values.
3. **"START"**: begins workout. When the power is on and safety key correctly placed on the computer, press this button to start the treadmill.
4. **"STOP"**: press button to stop the motor running
5. **SPEED+ \ SPEED-**: Increase or decrease speed when exercising. Sets parameter when stopped.
6. **"INCLINE+"**, **"INCLINE-"**: increase or decreases incline. Adjust the incline gradient during exercising. Sets parameter when stopped.
7. **"SPEED: 3, 5, 8, 10, 12, 15"** – Speed shortcut button
8. **"INCL: 3, 5, 8, 10, 12, 15"** – incline shortcut button
9.  Fan button: start or stop the fan (optional).

### 3. MAIN FUNCTIONS

#### 3.1. Quick Start-up (Manual):

Attach the safety key. After a 3 second countdown, the treadmill will starting and running from the lowest speed, add and subtract to the speed using the SPEED button.

#### 3.2. Countdown mode:

Press the MODE button to cycle options: time countdown, distance countdown, calories countdown. The default value corresponds to the window and flashing display. At this point the SPEED buttons serve as a plus and minus functions to adjust to the desired value. Press the START, add and subtract speed by using SPEED buttons once again. When the countdown reaches 0, the machine will stop. You can also directly press the STOP button or disconnect safety lock to stop.

Timer countdown: press the MODE button to enter the time countdown mode, the time display will show 0:00 adjust desired workout time with speed arrow buttons. Time setting range: 5:00-99:00.

Distance countdown: cycle modes using the MODE button to enter the distance mode, the range display will show 0:0; adjust desired workout distance with speed arrow buttons. Distance setting range is 0.5-99.0 km.

Calorie countdown: cycle modes using the MODE button to enter the calorie mode, the calorie display will show 0:0; adjust desired workout calories with speed arrow buttons. Calorie setting range is 10-999 calories kcal.

#### 3.3. Preset programs:

Press the program button; programs from P1 to P12 are built-in programs. The time window displays the default value of TIME. When flashing, press the SPEED buttons to adjust to your desired time. Built-in programs are divided into 10 equal segments. After press the START button, the treadmill will automatically cycle through the time segments. Speed will automatically adjust to the preset value for the segment. Upon completion of the segments, the program will end, slowing the treadmill down to a stop. During the operation speed can be adjusted but the next segment will be automatically adjusted to the program defaults. Built-in program data is listed on the table.

### 3.4. User-defined program

#### 1. Setting

Press “program” continually until you reach U1, U2 or U3. The “time” window will glitter and display “15:00” in the time window.

Press “incline+”, “incline-”, “speed+”, “speed-” to adjust the running time

Press “mode” to set program data, set the first interval time

Press “speed+”, “speed-” or press speed shortcut buttons to adjust speed and “incline+”, “incline-” or incline shortcut buttons to set the incline

Press “mode” button to finish the first interval time and enter into the second interval time.

Repeat until you finished entering all 20 interval times. The data will be retained until it is overwritten.

#### 2. Startup

Press “program” continually until you reach U1, U2 or U3.

Set the running time then press “start” to start the machine.

### 4. VALUE RANGE:

	PROGRAM	BEGIN	SET UP RANGE	DISPLAY RANGE
TIME(MIN:SECOND)	0:00	15:00	5:00-99:00	0:00 - 99:59
INCLINE(LEVEL)	0	0	0-20	0-20
SPEED(K/h)	1.0	1.0	1.0-18	1.0-18
DISTANCE(K)	0	1.0	0.5-99.9	0.00 - 99.9
PULSE(hypo/min)	P	N/A	N/A	50-200
CALORIE(THERM)	0	50	10-999	0 - 999

## 5. HEART RATE:

When holding the hand pulse with two hands, the pulse window will show your heart rate after 5 seconds.

To increase accuracy please check heart rate with the machine stopped and after keeping your hands on the sensors for more than 30 seconds.

**The heart rate data is for reference purposes ONLY.**

## 6. BODY FAT TESTER

Press "PROGRAM" until the window displays "FAT".

Press "MODE" to select parameters after entering data (F1 = "SEX", F2 = "AGE", F3 = "HEIGHT", F4 = "WEIGHT").

Use "SPEED+/-" to set data. After entering all data the window will display "F5".

Place both hands on the hand sensors for 5 seconds, and the window will display your body fat data.

### Input parameter display and setting limits

F-1	Sex	01 male	02 female
F-2	Age	10-----99	
F-3	Height	100----200	
F-4	Weight	20-----150	
F-5	FAT	≤19	Under weight
	FAT	=(20---25)	Normal weight
	FAT	=(25---29)	Over weight
	FAT	≥30	Obese

## 7. SLEEP FUNCTION:

The treadmill automatically enters sleep mode after 10 minutes of inactivity. Press any key on the display to wake the treadmill.



## 8. EXERCISE GUIDE

**PLEASE NOTE:** Before beginning any exercise program, consult your physician. This is important especially if you are over the age of 45 or individuals with pre-existing health problems.

The pulse sensors are not medical devices. Various factors, including the user's movement, may affect the accuracy of heart rate readings. The pulse sensors are intended only as an exercise aid in determining heart rate trends in general.

Exercising is great way to control your weight, improving your fitness and reduce the effect of aging and stress. The key to success is to make exercise a regular and enjoyable part of your everyday life.

The condition of your heart and lungs and how efficient they are in delivering oxygen via your blood to your muscles is an important factor to your fitness. Your muscles use this oxygen to provide enough energy for daily activity. This is called aerobic activity. When you are fit, your heart will not have to work so hard. It will pump a lot fewer times per minute, reducing the wear and tear of your heart.

So as you can see, the fitter you are, the healthier and greater you will feel.

### Warm-up

Start each workout with 5 to 10 minutes of stretching and some light exercises. A proper warm-up increases your body temperature, heart rate and circulation in preparation for exercise. Ease into your exercise.

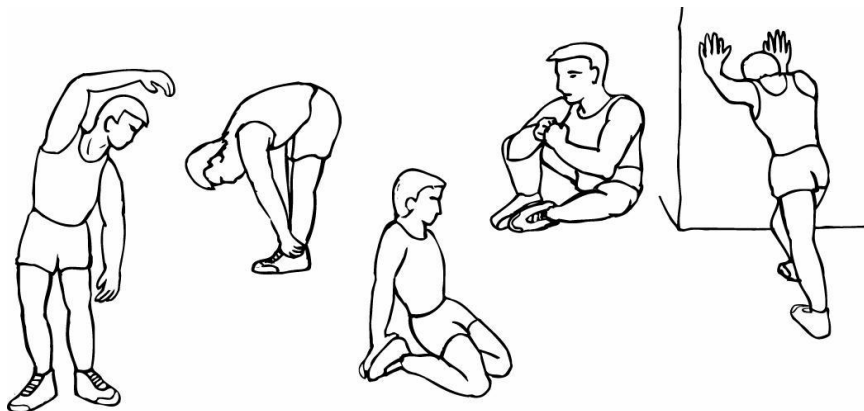

### Training Zone Exercise

After warming up, increase the intensity to your desired exercise program. Be sure to maintain your intensity for maximum performance. Breathe regularly and deeply as you exercise-never hold your breath.

### Cool Down

Finish each workout with a light jog or walk for at least 1 minute. Then complete 5 to 10 minutes of stretching to cool down. This will increase the flexibility of your muscles and will help prevent post-exercise problems.

## Workout Guidelines

### TARGET ZONE

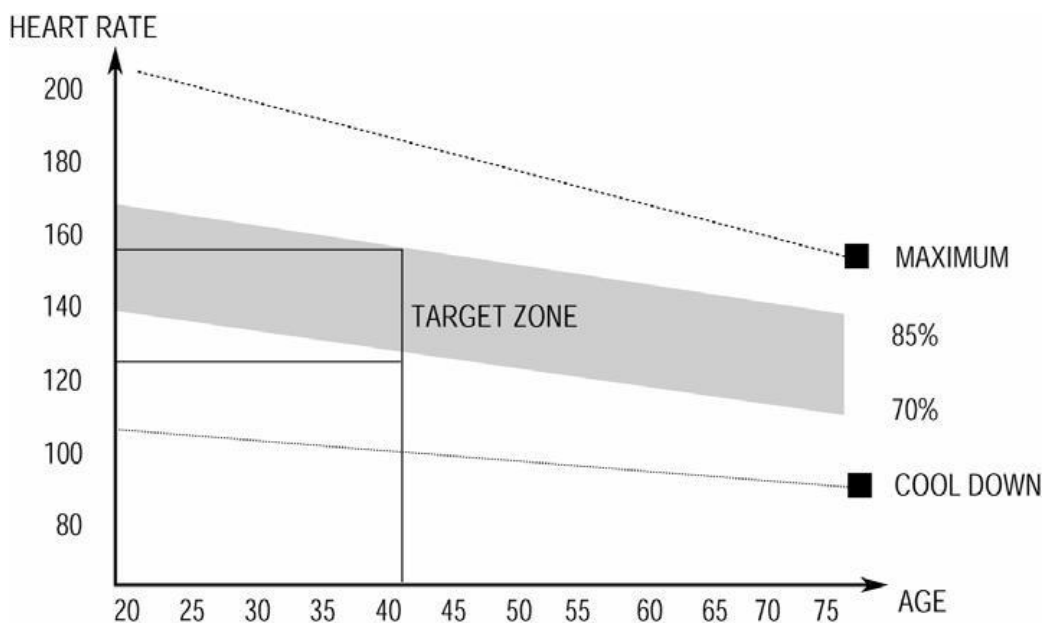

**THIS IS HOW YOUR PULSE SHOULD BEHAVE DURING GENERAL FITNESS EXERCISE.**

**REMEMBER TO WARM UP AND COOL DOWN FOR A FEW MINUTES.**

The most important factor here is the amount of effort you put in. The harder and longer you work, the more calories you will burn. Effectively this is the same as if you were training to improve your fitness, the difference is the goal.

## 9. MAINTENANCE INSTRUCTIONS

Reasonable cleaning/lubricating should be made to extend the life time of this unit. Performance is maximized when the belt and mat are kept as clean as possible.

**WARNING: THE MAT/DECK FRICTION MAY PLAY A MAJOR ROLE IN THE FUNCTION AND LIFE OF YOUR TREADMILL AND THAT IS WHY WE RECOMMEND YOU CONSTANTLY LUBRICATE THIS FRICTION POINT TO PROLONG THE USEFUL LIFE OF YOUR TREADMILL. FAILING TO DO THIS MAY VOID YOUR WARRANTY.**

**WARNING: UNPLUG POWER CORD BEFORE MAINTENANCE**

**WARNING: STOP TREADMILL BEFORE FOLDING**

### 1. General Cleaning

- Use a soft, damp cloth to wipe the edge of the belt and the area between the belt edge and frame. A mild soap and water solution along with a nylon scrub brush will clean the top of the textured belt. This task should be done once a month. Allow to dry before using.
- On a monthly basis, vacuum underneath your treadmill to prevent dust build up. Once a year, you should remove the black motor shield and vacuum out dirt that may accumulate.

### 2. General Care

- Check parts for wear before use.
- Pay particular attention to the fixing knobs and make sure they are tight.
- Always replace the mat if worn and any other defective parts.

- If in doubt do not use the treadmill and contact our helpline.

TAKE CARE TO PROTECT CARPETS AND FLOOR in case of leakages. This product is a machine that contains moving parts which have been greased / lubricated and could leak.

### **3. Belt/Deck/Roller Lubrication**

The mat/deck friction may play a major role in the function and life of your treadmill and that is why we recommend you constantly lubricate this friction point to prolong the useful life of your treadmill. Lubrication is provided with this unit. You should apply the enclosed lubrication after approximately the first 50 hours of operation. We recommend lubrication of the deck according to the following timetable:

- Light use (less than 3 hours per week) every 6 months
- Medium use (3-5 hours a week) every 3 months
- Heavy use (more than 5 hours per week) every 6-8 weeks

See below procedures for lubricating:

1. Use a soft, dry cloth to wipe the area between the belt and deck.
2. Spread lubricant onto the inside surface of belt and deck evenly (make sure the machine is turned off and power is disconnected).
3. Periodically lubricate the front and rear rollers to keep them at their peak performance. If the treadmill belt/deck/roller is kept reasonably clean it is possible to expect over 1200 hours before relubricating is necessary.

### **4. How to check the running mat for proper lubrication:**

1. Disconnect the main power supply.
2. Fold the treadmill up into the storage position.
3. Feel the underside surface of the running mat.

If the surface is slick when touched, then no further lubrication is needed.

If the surface is dry to the touch, apply a suitable silicone lubricant.

**We recommend that you use a silicone based spray to lubricate your Lifespan treadmill. This can be purchased from your local sports retailer or hardware store.**

## 5. Belt Tension Adjustment

It is very important for joggers and runners in order to provide a smooth, steady running surface. Adjustment must be made from the right and left rear roller in order to adjust tension with the Allen Key provided in the parts package. The adjustment bolt is located at the end of the rails as noted in the diagram below:

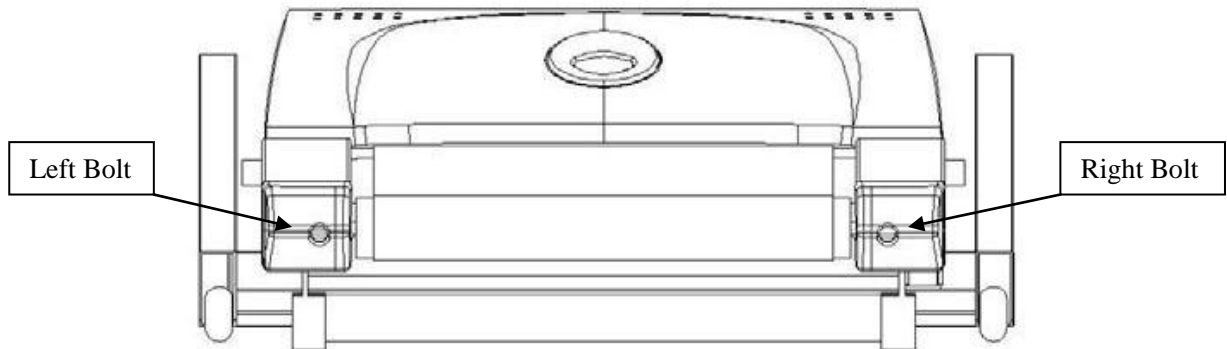

**Note: Adjustment is through small hold of end cap.**

Tighten the rear roller only enough to prevent slippage at the front roller. Turn both the right and left bolt clockwise one full turn and inspect for proper tension. When an adjustment is made to the belt tension, you must also make a tracking adjustment to compensate for the change in belt tension.

DO NOT OVER TIGHTEN - Over tightening will cause belt damage and premature bearing failure.

This may also cause reduced motor performance and excessive roller wear.

**NOTE:** When properly tightened, the sides of the belt can be raised approximately 2-3 inches off the board.

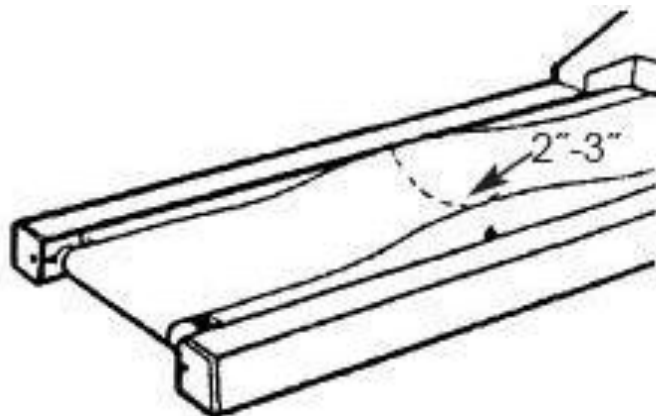

## 6. Belt Tracking Adjustment:

This treadmill is designed to keep the belt reasonably centred while in use. It is normal for some belts to drift near one side while the belt is running with no one on it. After a few minutes of use, the belt should have a tendency to centre itself. If during use, the belt continues to move toward one side, adjustments are necessary. The procedures are below:

1. Set speed at approximately 3.5km/h.
2. Check the side the belt shifts to.

If the belt shifts to right, tighten the right bolt and loosen the left bolt by using 6mm Allen Key, until the belt is centred itself; If belt shifts to left, tighten the left bolt and loosen the right bolt by using a 6mm Allen Key, until the belt is centred. When adjusting the belt using the 6 mm Allen Key, it is important to adjust the belt in half turn increments. Over adjusting the belt can cause damage to the mat.

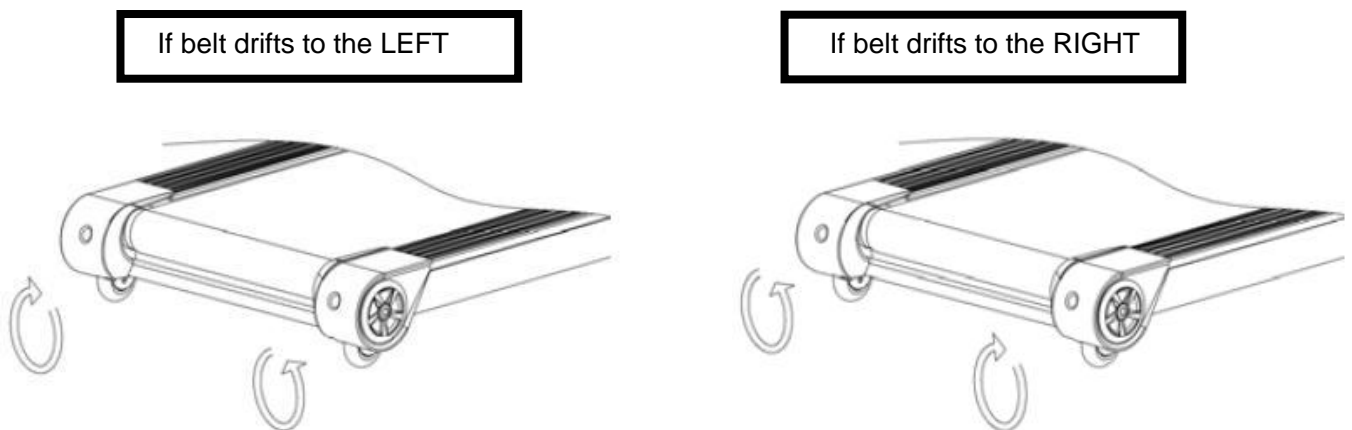

# 10. EXPLODED DIAGRAM

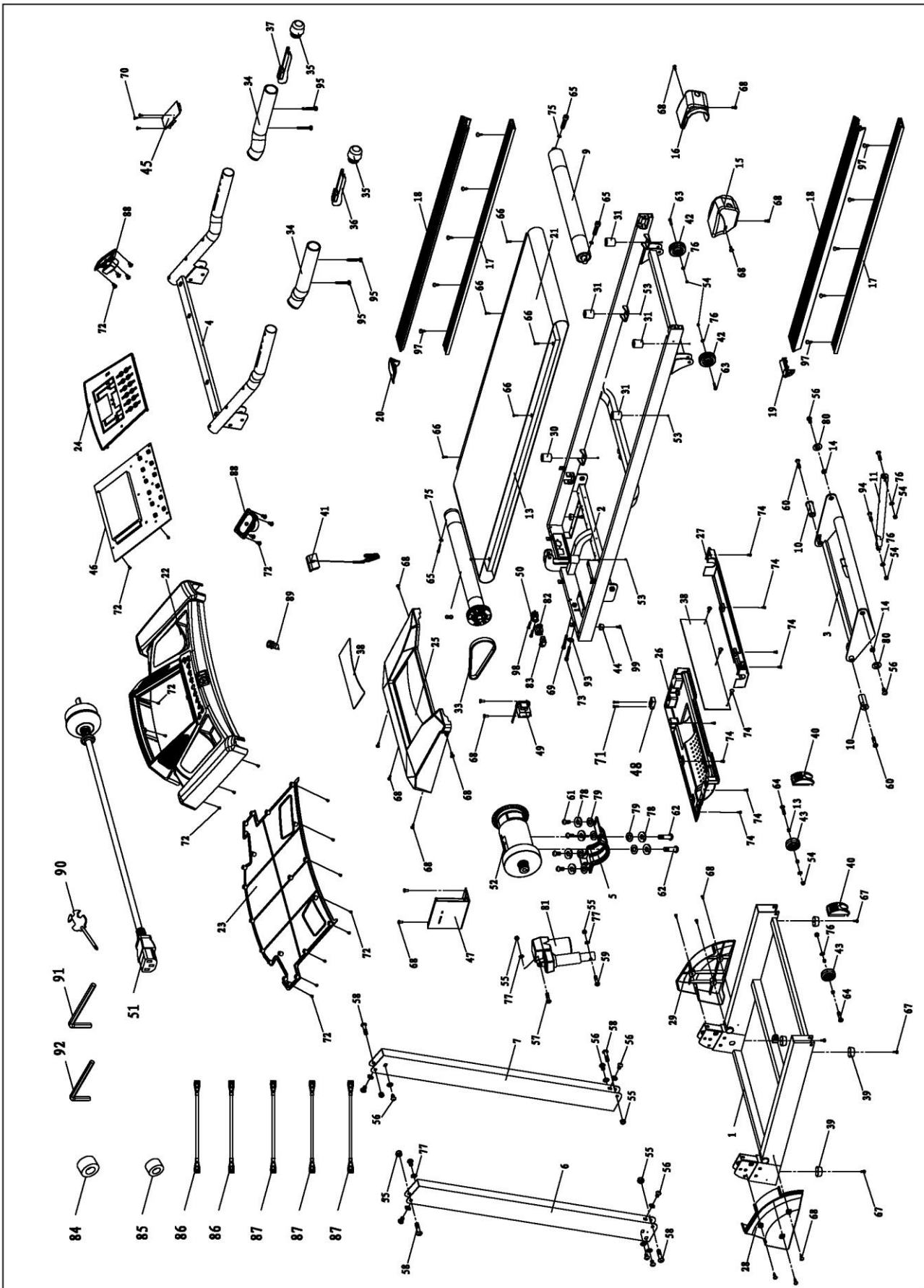

# 11. PARTS LIST

#.	DESCRIPTION	REMARK	QTY	#.	DESCRIPTION	REMARK	QTY
1	Base Frame		1	38	Baffle		1
2	Main Frame		1	39	Flat foot pad		4
3	Incline Bracket		1	40	Wheel casing plug		2
4	Computer Bracket		1	41	Safety Key		1
5	Motor Bracket		1	42	Adjustable Wheel		2
6	Left Upright Tube		1	43	Transport Wheel		2
7	Right Upright Tube		1	44	Foot pad		2
8	Front Roller		1	45	Amplifier Board		1
9	Rear Roller		1	46	Computer Board		1
10	Turn Bushing		1	47	Control Board		1
11	Air Pressure Bar		1	48	Magnet Sensor		1
12	Running Board		1	49	Transformer		1
13	Wheel casing plug		1	50	Power Outlet		1
14	Incline turn casing		1	51	Power wire		1
15	Left Back End Cover		1	52	DC Motor		1
16	Right Back End Cover		1	53	Lock Nut	M6	8
17	Inner Side Rail		2	54	Lock Nut	M8	6
18	Outter Side Rail		2	55	Lock Nut	M10	6
19	End cap of Left Side Rail		1	56	Bolt	M10*15	12
20	End cap of Right Side Rail		1	57	Bolt	M10*40 L15	1
21	Running Belt		1	58	Bolt	M10*50 L15	4
22	Computer Top Cover		1	59	Bolt	M10*55 L20	1
23	Computer Bottom Cover		1	60	Bolt	M10*60 L20	2
24	Computer Panel		1	61	Bolt	M8*15	4
25	Motor Cover		1	62	Bolt	M8*25 L15	2
26	Motor Bottom Cover		1	63	Bolt	M8*40 L20	2
27	Bottom Cover Board		1	64	Bolt	M8*50 L20	2
28	Left Upright Tube Cover		1	65	Bolt	M6*55	3
29	Right Upright Tube Cover		1	66	Bolt	M6*25	8
30	Blue Cushion Pad		4	67	Bolt	M5*16	10
31	Black Cushion Pad		2	68	Bolt	M5*8	9
32	Arcylic		1	69	Bolt	M8*55	1
33	Motor Belt		1	70	Screw	S T2.9*6.5	39
34	Foam		2	71	Screw	S T2.9*8	2



35	Handle Bar Plug Hand Pulse with		2	72	Screw	ST4.2*12	19
36	Incline Button Hand Pulse with		1	73	Screw	M8*60	1
37	Speed Button		1	74	Screw	ST4.2*12	16
75	Lock Washer	GB861.2-87 6	3				
76	Lock Washer	GB861.2-87 8	16				
77	Lock Washer	GB861.2-87 10	12				
78	Spring Washer	GB/T 93-1987 8	6				
79	Flat Washer	GB/ T 95-2002 8	7				
80	Flat Washer	GB/T 95-2002 10	2				
81	Incline Motor		1				
82	Square Switch		1				
83	Overload protector		1				
84	Magnet Ring		1				
85	Magnet Core		1				
86	AC Single Wire		2				
87	AC Single Wire		3				
88	Speaker		2				
89	Emergency Button		1				
90	Wrench w/screw Driver	S=13,14,15	1				
91	5# Allen Wrench	5mm	1				
92	6# Allen Wrench	6mm	1				
93	Big Washer	φ8*φ22*2.0	1				
94	Bolt	M8*30 L15	1				
95	Screw	ST4.2*30	4				
96	Screw	ST4.2*12	8				
97	Screw	ST4.2*25	2				
98	Screw	ST2.9*8	2				

## 12. TROUBLE SHOOTING GUIDE

Error/Code	Description	Possible Solutions
	Computer not functioning after connecting power	<ol style="list-style-type: none"> <li>a. Please check if the overload protect jump, if it has, please press it, let it continue operation.</li> <li>b. Ensure the wires of the power switch, overload protection, control board and the transformer are connected correctly.</li> <li>c. Ensure the wire from the computer to the control board is connected properly. Remove the upright tube and check the connection between each wire. Ensure each wire is completely plugged in; if wires are damaged please change the wire.</li> <li>d. Check the state of the transformer is good, if broken, change it.</li> </ol>
E01	Message failure	<ol style="list-style-type: none"> <li>1. The wires from computer and bottom control board are not properly connected, please check each wire. If the wire was destroyed replace it.</li> <li>2. Check the state of the transformer is good, if broken, change it.</li> </ol>
E02	Burst clash	<ol style="list-style-type: none"> <li>1. Ensure power is correct, if not, use correct power to test.</li> <li>2. Check if the bottom control is burnt out, if burnt out replace it and then reconnect the motor wire.</li> </ol>
E03	No sensor signal	<ol style="list-style-type: none"> <li>1. The sensor signal was not detected within 10 seconds. Check the sensor plug connection</li> <li>2. See if the magnetic sensor is broken or damaged, re-connect the plug well or change the sensor.</li> </ol>

E04 or E06	Incline learning defeated	<ol style="list-style-type: none"> <li>1. Check connection of VR wire of incline motor. If improperly connected, reconnect VR and make it firm.</li> <li>2. Check to see if AC wire of motor is properly connected, and if the AC wire of the motor is inserted properly with correct sign on control board.</li> <li>3. Check connection line of motor to see if it is destroyed, exchange it or incline motor. And press “learning” button of bottom control board to relearn upon completion of checks.</li> </ol>
E05	Overload protection	<ol style="list-style-type: none"> <li>1. Upon overload, the system will restart to prevent damage. If the treadmill gets stuck and the motor cannot move it will lead to an overload. Please locate the cause of this. A possible reason is a lack of lubricant in a particular component. Then restart the machine.</li> <li>2. Check if the motor sounds like its being over worked or for a burning smell. If so, change motor</li> <li>3. Check control board. If control board is emitting a burning smell, change it.</li> </ol>
E07	No signal between the control board and computer	<ol style="list-style-type: none"> <li>1. The wires from computer and bottom control board are not properly connected, please check each wire. If the wire is destroyed replace it.</li> <li>2. Ensure wires of control board are properly connected, replace any broken parts on the board</li> <li>3. Replace transformer</li> </ol>
E08	Control board problem	<ol style="list-style-type: none"> <li>1. Replace controller</li> </ol>
E09	Machine is folded	<ol style="list-style-type: none"> <li>1. Ensure that the machine is correctly unfolded, restart.</li> <li>2. Replace transformer</li> </ol>

	<p>Motor not functioning after pressing START button</p>	<ol style="list-style-type: none"> <li>1. the motor wire is broken; the safety pipe is broken or has fallen off;</li> <li>2. motor wire is not properly connected</li> <li>3. IGBT on bottom control board is burnt out. Test the above reasons and change the relevant part.</li> </ol>
--	----------------------------------------------------------	------------------------------------------------------------------------------------------------------------------------------------------------------------------------------------------------------------------------------------------------------------------------------------------

## 13. WARRANTY

### AUSTRALIAN CONSUMER LAW

*Many of our products come with a guarantee or warranty from the manufacturer. In addition, they come with guarantees that cannot be excluded under the Australian Consumer Law. You are entitled to a replacement or refund for a major failure and compensation for any other reasonably foreseeable loss or damage.*

*You are entitled to have the goods repaired or replaced if the goods fail to be of acceptable quality and the failure does not amount to a major failure. Full details of your consumer rights may be found at [www.consumerlaw.gov.au](http://www.consumerlaw.gov.au)*

Please visit our website to view our full warranty terms and conditions:

<http://www.lifespanonline.com.au/Warranty-Policy>

## 14. PROGRAM GUIDE

		SECTION									
		1	2	3	4	5	6	7	8	9	10
P1	SPEED	3	3	5	5	7	7	5	5	3	3
	INCLINE	1	1	2	2	2	3	3	2	1	1
P2	SPEED	10	3	5	7	3	7	5	7	5	3
	INCLINE	1	2	2	2	2	3	3	2	3	3
P3	SPEED	3	3	5	7	7	9	7	5	5	1
	INCLINE	2	3	3	2	2	3	3	3	4	4
P4	SPEED	3	5	3	7	1	5	7	5	3	1
	INCLINE	2	3	3	2	2	3	3	3	4	0
P5	SPEED	5	5	5	7	9	11	9	7	7	5
	INCLINE	3	3	3	4	4	5	5	5	5	2
P6	SPEED	3	5	9	11	7	12	9	11	5	3
	INCLINE	3	5	5	5	4	4	4	3	4	2
P7	SPEED	3	7	9	11	9	9	9	7	5	5
	INCLINE	4	4	4	4	3	3	6	6	8	3
P8	SPEED	5	5	9	9	11	5	11	11	5	3
	INCLINE	4	5	5	5	6	6	6	7	10	3
P9	SPEED	2	5	5	8	8	4	6	3	3	2
	INCLINE	5	5	5	6	6	6	4	4	8	2
P10	SPEED	2	3	4	6	7	5	5	6	7	3
	INCLINE	5	6	6	6	7	5	8	8	5	3
P11	SPEED	3	4	5	9	5	9	5	5	6	3
	INCLINE	3	6	5	3	5	3	5	5	4	2
P12	SPEED	1	2	3	10	7	7	10	5	4	3
	INCLINE	2	5	5	3	5	5	3	3	6	2
P13	SPEED	1	1	3	5	5	5	9	3	1	1
	INCLINE	5	5	8	8	8	3	3	7	8	0
P14	SPEED	3	4	7	3	4	6	3	4	5	3
	INCLINE	2	4	4	4	4	2	3	3	1	0
P15	SPEED	2	3	5	5	7	7	7	6	4	3
	INCLINE	3	3	5	5	5	5	2	2	1	0
P16	SPEED	2	3	5	4	5	5	7	5	4	2
	INCLINE	0	2	2	4	4	6	6	1	1	0
P17	SPEED	2	6	8	3	9	4	12	4	3	2
	INCLINE	5	5	10	10	3	3	3	7	1	0
P18	SPEED	1	5	4	5	9	5	4	5	3	2
	INCLINE	5	5	8	8	10	10	10	7	2	0

P19	SPEED	3	4	8	4	3	8	6	4	3	1
	INCLINE	2	4	4	4	4	2	3	3	1	0
P20	SPEED	3	2	3	6	6	6	6	5	3	3
	INCLINE	3	3	5	5	5	5	2	2	1	0
P21	SPEED	2	6	5	6	8	6	7	4	3	2
	INCLINE	2	3	3	3	4	4	1	1	2	0
P22	SPEED	2	4	6	8	10	8	6	4	6	6
	INCLINE	2	3	6	6	3	5	8	3	5	3
P23	SPEED	2	4	6	8	4	2	7	8	12	1
	INCLINE	3	6	5	3	5	3	5	5	4	2
P24	SPEED	2	4	6	4	6	8	10	8	6	4
	INCLINE	2	5	5	3	5	5	3	3	4	2
P25	SPEED	2	2	2	6	6	10	11	4	8	2
	INCLINE	5	5	8	8	8	3	3	5	8	0
P26	SPEED	2	4	10	12	4	10	4	10	4	2
	INCLINE	2	2	2	2	2	2	3	3	1	0
P27	SPEED	2	6	4	8	4	8	6	10	8	2
	INCLINE	3	3	6	6	6	6	2	2	1	0
P28	SPEED	2	4	6	8	10	4	6	8	10	2
	INCLINE	0	2	2	5	5	5	5	1	1	0
P29	SPEED	2	4	6	8	12	2	2	4	8	2
	INCLINE	5	5	10	10	3	3	3	8	2	0
P30	SPEED	2	4	6	10	8	4	10	6	10	2
	INCLINE	5	5	8	8	10	10	10	4	4	0
P31	SPEED	2	3	3	4	5	3	4	5	4	3
	INCLINE	1	1	3	3	3	3	3	2	2	1
P32	SPEED	2	4	4	5	6	4	6	5	4	2
	INCLINE	1	2	3	3	3	3	3	2	3	2
P33	SPEED	2	4	4	6	6	4	7	5	3	2
	INCLINE	2	3	4	3	4	3	3	3	4	2
P34	SPEED	3	5	5	6	7	7	5	7	9	3
	INCLINE	2	3	3	2	2	4	4	4	4	0
P35	SPEED	2	4	4	5	6	7	7	5	2	2
	INCLINE	3	3	3	4	4	5	5	5	5	2
P36	SPEED	2	4	4	4	5	5	5	8	6	2
	INCLINE	3	5	5	5	4	4	4	3	4	2
P37	SPEED	2	3	3	3	2	5	2	4	3	3
	INCLINE	4	4	4	3	3	6	6	8	3	1
P38	SPEED	2	3	3	6	9	9	9	9	4	2
	INCLINE	4	5	5	5	6	6	6	7	10	3

P39	SPEED	2	4	4	7	9	4	9	8	4	2
	INCLINE	5	5	5	6	6	6	4	4	8	2
P40	SPEED	2	4	5	6	7	9	4	9	5	3
	INCLINE	5	6	6	6	7	5	8	8	5	3
P41	SPEED	3	4	5	9	5	9	5	5	5	3
	INCLINE	3	6	5	3	5	3	5	5	4	2
P42	SPEED	2	5	8	10	7	7	10	10	9	3
	INCLINE	2	5	5	3	5	5	3	3	6	2
P43	SPEED	1	1	3	3	3	4	4	4	5	1
	INCLINE	5	5	8	8	8	3	3	6	8	0
P44	SPEED	3	4	6	3	4	6	3	4	6	3
	INCLINE	2	4	4	4	4	2	5	5	1	0
P45	SPEED	3	4	7	5	7	6	7	5	7	3
	INCLINE	3	3	5	5	5	5	3	3	1	0
P46	SPEED	3	3	3	5	5	5	5	5	7	2
	INCLINE	0	2	2	5	5	5	5	1	1	0
P47	SPEED	2	2	4	4	4	3	4	4	4	2
	INCLINE	5	5	10	10	6	6	6	7	9	0
P48	SPEED	1	3	4	4	4	4	5	5	5	2
	INCLINE	5	5	7	7	10	10	10	7	4	0
P49	SPEED	3	4	6	4	4	6	6	6	7	1
	INCLINE	2	3	3	3	3	2	0	2	1	0
P50	SPEED	3	4	4	7	7	7	7	7	6	3
	INCLINE	3	3	2	2	2	2	2	2	2	0
P51	SPEED	2	4	4	4	4	4	7	7	6	2
	INCLINE	2	3	3	3	2	2	1	4	4	0
P52	SPEED	2	4	6	8	10	8	6	4	10	4
	INCLINE	2	3	6	2	8	10	15	8	6	3
P53	SPEED	2	4	6	6	8	6	8	8	6	4
	INCLINE	3	6	5	5	4	6	8	14	5	2
P54	SPEED	2	4	7	4	6	8	10	8	6	1
	INCLINE	2	5	5	6	8	4	6	6	13	2
P55	SPEED	2	2	2	9	8	7	10	10	4	1
	INCLINE	5	5	9	8	9	4	4	4	4	0
P56	SPEED	2	2	4	9	10	12	4	4	10	1
	INCLINE	2	2	2	6	6	0	0	2	1	0
P57	SPEED	2	6	4	9	8	8	6	10	8	1
	INCLINE	3	3	6	1	2	2	2	2	2	0
P58	SPEED	2	4	3	8	10	2	4	6	6	1
	INCLINE	0	2	2	3	3	3	1	1	1	0

P59	SPEED	2	4	3	8	10	12	10	8	8	1
	INCLINE	5	5	10	9	9	4	4	4	4	0
P60	SPEED	2	4	2	10	8	4	10	6	10	1
	INCLINE	5	5	8	9	9	4	4	4	4	0
P61	SPEED	1	4	6	6	6	6	9	9	6	1
	INCLINE	2	3	6	2	8	10	15	8	6	3
P62	SPEED	2	6	6	6	6	6	10	8	4	2
	INCLINE	3	6	5	5	4	6	8	14	5	2
P63	SPEED	2	2	2	6	6	6	10	11	8	2
	INCLINE	2	5	5	6	8	4	6	6	13	2
P64	SPEED	2	2	4	4	10	12	4	5	4	2
	INCLINE	5	5	6	8	9	4	4	4	4	0
P65	SPEED	2	6	4	8	4	8	6	10	4	2
	INCLINE	2	2	7	6	6	0	0	2	1	0
P66	SPEED	2	4	6	8	12	2	6	6	10	2
	INCLINE	3	3	6	1	2	2	2	2	2	0
P67	SPEED	2	4	7	8	12	12	12	8	9	2
	INCLINE	0	2	2	3	3	3	1	1	1	0
P68	SPEED	2	4	6	12	8	4	12	7	10	2
	INCLINE	5	5	10	9	9	4	4	4	4	0
P69	SPEED	2	3	3	4	5	4	4	3	4	3
	INCLINE	5	5	6	9	9	4	4	4	4	0
P70	SPEED	2	4	4	6	6	4	6	6	4	2
	INCLINE	1	1	5	1	1	3	3	2	2	2
P71	SPEED	2	4	4	6	6	4	9	8	3	2
	INCLINE	1	2	5	3	3	4	4	3	2	2
P72	SPEED	3	5	5	6	8	8	5	8	4	3
	INCLINE	2	3	4	4	4	6	6	3	2	2
P73	SPEED	2	4	4	5	6	8	8	8	4	2
	INCLINE	2	3	3	4	6	6	3	2	2	0
P74	SPEED	2	4	3	4	5	8	9	8	3	2
	INCLINE	3	3	3	5	3	3	3	2	2	2
P75	SPEED	2	3	2	5	8	8	3	5	3	3
	INCLINE	3	5	5	4	3	3	3	4	3	2
P76	SPEED	2	3	3	6	4	2	3	4	4	2
	INCLINE	4	4	4	9	9	6	6	5	3	3
P77	SPEED	2	4	4	8	8	5	6	3	3	2
	INCLINE	4	5	5	10	10	12	12	8	6	3
P78	SPEED	2	4	5	7	9	5	4	4	2	3
	INCLINE	5	5	5	8	9	9	9	7	4	2



P79	SPEED	3	4	5	9	5	7	5	9	6	3
	INCLINE	5	6	6	8	8	10	10	8	6	3
P80	SPEED	2	5	7	6	11	10	6	5	4	3
	INCLINE	3	6	5	5	3	3	2	4	5	2
P81	SPEED	1	1	3	3	2	5	4	3	1	1
	INCLINE	2	5	5	6	4	4	6	6	3	2
P82	SPEED	3	4	6	4	2	2	6	3	4	3
	INCLINE	5	5	8	8	9	4	4	4	4	0
P83	SPEED	3	4	7	5	7	2	6	4	4	3
	INCLINE	2	4	4	6	6	0	0	2	1	0
P84	SPEED	3	3	3	5	7	5	7	6	2	2
	INCLINE	3	3	5	1	2	2	2	2	2	0
P85	SPEED	2	2	4	3	3	3	4	4	2	2
	INCLINE	0	2	2	3	3	3	1	1	1	0
P86	SPEED	1	3	4	3	3	4	5	5	3	2
	INCLINE	5	5	10	9	9	4	4	4	4	0
P87	SPEED	3	4	6	9	9	9	9	6	2	1
	INCLINE	5	5	7	9	9	4	4	4	4	0
P88	SPEED	3	4	5	5	5	5	7	7	3	3
	INCLINE	2	3	3	6	6	0	0	2	1	0
P89	SPEED	2	4	4	5	5	4	7	7	3	2
	INCLINE	3	3	2	1	2	2	2	2	2	0
P90	SPEED	2	4	9	9	10	8	6	4	4	3
	INCLINE	2	3	3	5	5	4	4	4	4	0
P91	SPEED	2	4	6	8	8	3	8	9	12	2
	INCLINE	2	3	6	2	8	10	15	8	6	3
P92	SPEED	2	4	7	8	8	8	10	4	8	1
	INCLINE	3	6	5	5	4	6	8	14	5	2
P93	SPEED	2	2	8	9	8	8	10	7	8	1
	INCLINE	2	5	5	6	8	4	6	6	13	2
P94	SPEED	2	2	4	9	12	12	4	10	4	1
	INCLINE	5	5	9	8	9	4	4	4	4	0
P95	SPEED	1	2	3	4	5	6	7	8	4	2
	INCLINE	2	2	2	6	6	0	0	2	1	0
P96	SPEED	2	12	3	12	12	3	4	8	10	1
	INCLINE	3	3	6	1	2	2	2	2	2	0
P97	SPEED	2	4	2	8	2	12	2	4	8	1
	INCLINE	0	2	2	3	3	3	1	1	1	0

P98	SPEED	2	4	2	12	1	4	12	6	10	1
	INCLINE	5	5	10	9	9	4	4	4	4	0
P99	SPEED	2	4	2	12	8	4	12	6	10	1
	INCLINE	5	5	8	9	9	4	4	4	4	0