

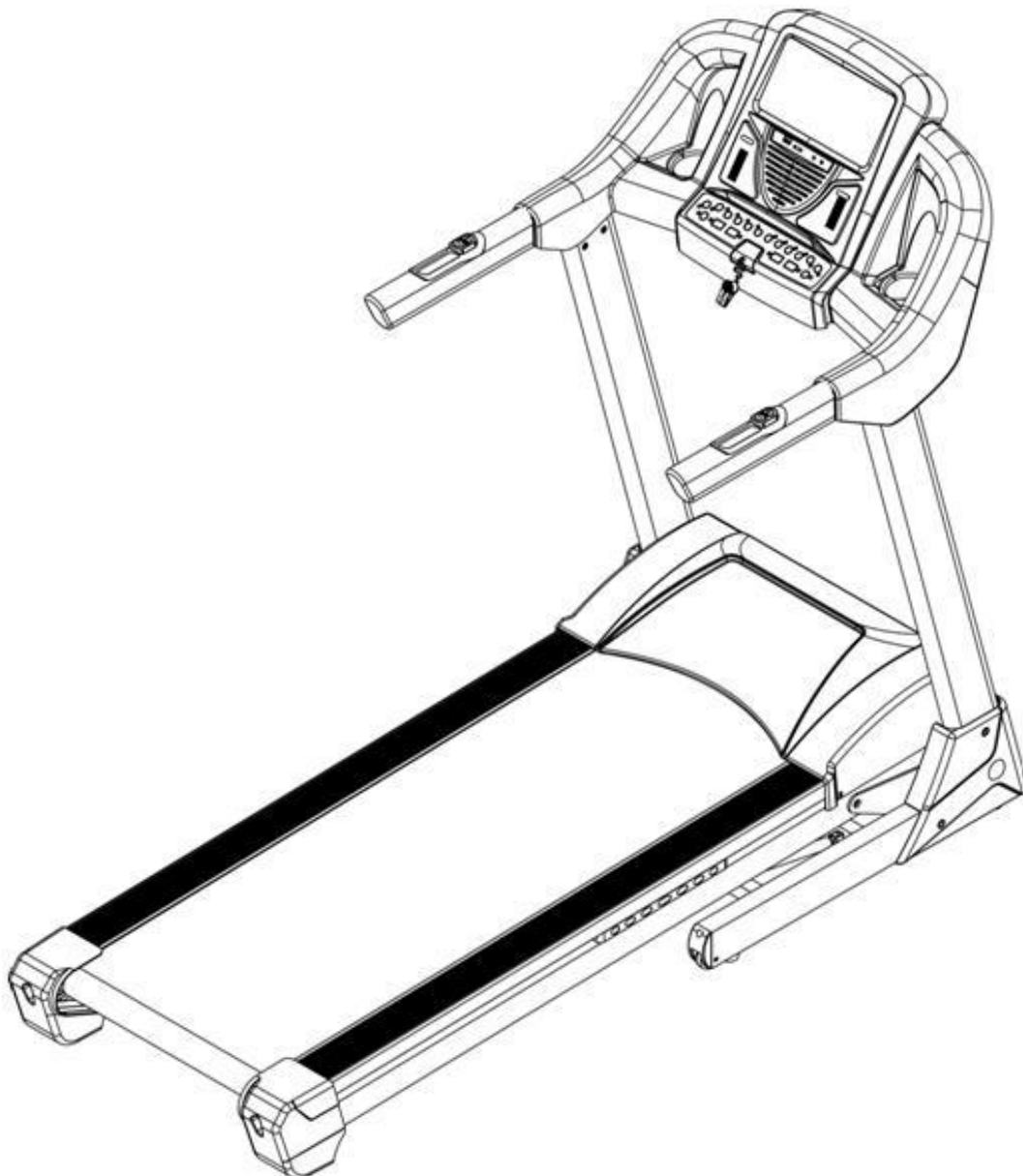

LIFESPAN

FITNESS

GOLD 2.0H OWNER'S MANUAL



Product may vary slightly from the item pictured due to model upgrades.

Read all instructions carefully before using this product. Retain this owner's manual for future reference.

TABLE OF CONTENTS

1.	IMPORTANT SAFETY INSTRUCTIONS	3
2.	IMPORTANT ELECTRICAL INFORMATION	5
3.	IMPORTANT OPERATING INSTRUCTIONS	6
4.	ASSEMBLY INSTRUCTIONS	7
5.	FOLDING INSTRUCTIONS	11
6.	OPERATION GUIDE	12
7.	EXERCISE GUIDE	18
8.	MAINTENANCE GUIDE	20
9.	EXPLODED DIAGRAM	28
10.	PARTS LIST	29
11.	WARRANTY	31
12.	PRESET PROGRAM LIST	34
13.	HRC PROGRAM LIST	38

1. IMPORTANT SAFETY INSTRUCTIONS

WARNING - Read all instructions before using this treadmill.

It is important your treadmill receives regular maintenance to prolong its useful life. Failing to regularly maintain your treadmill may void your warranty.

Danger – To reduce the risk of electric shock disconnect your treadmill from the electrical outlet prior to cleaning and/or service work.

DO NOT USE AN EXTENSION CORD: DO NOT ATTEMPT TO DISABLE THE GROUNDED PLUG BY USING IMPROPER ADAPTERS OR IN ANY WAY MODIFY THE CORD SET.

- Install the treadmill on a flat level surface with access to a 220-240 volt (50/60Hz), grounded outlet.
- Do not operate treadmill on deeply padded, plush or shag carpet. Damage to both carpet and treadmill may result.
- Do not block the rear of the treadmill. Provide a minimum of 1 metre clearance between the rear of the treadmill and any fixed object.
- Place your unit on a solid, level surface when in use
- When running, make sure the plastic clip is fastened on your clothing. It is for your safety, should you fall or move too far back on the treadmill.
- Keep hands away from all moving parts.
- Never operate the treadmill if it has a damaged power cord or plug. When damaged, these must be replaced by the manufacturer, its service agent or similarly qualified persons in order to avoid a hazard.
- Keep the cord away from heated surfaces.
- Do not operate where aerosol spray products are being used or where oxygen is being administered. Sparks from the motor may ignite a highly gaseous environment.
- Never drop or insert any object into any openings.

- The treadmill is intended for in-home use only and is not suitable for commercial environments.
- To disconnect, turn all controls to the off position, remove the safety key, and then remove the plug from the outlet.
- The pulse sensors are not medical devices. Various factors, including the user's movement, may affect the accuracy of heart rate readings. The pulse sensors are intended only as exercise aids in determining heart rate trends in general.
- Use the handrails provided; they are for your safety.
- Wear proper shoes. High heels, dress shoes, sandals or bare feet are not suitable for use on your treadmill. Quality athletic shoes are recommended to avoid leg fatigue.
- Before undertaking any type of exercise program, it is recommended that you consult a doctor.
- Injuries to health may result from incorrect or excessive training.
- This appliance is not intended for use by persons (including children) with reduced physical, sensory or mental capabilities, or lack of experience and knowledge, unless they have been given supervision or instruction concerning use of the appliance by a person responsible for their safety.
- WARNING heart rate monitoring systems may be inaccurate. If you feel faint stop exercising immediately.
- Children should not be allowed on or around the equipment, even when not in use.
- Children should be supervised to ensure that they do not play with this machine
- Loose-fitting clothing or jewellery that could become an entanglement hazard should not be worn.
- Training shoes should be worn when using the equipment.
- Equipment must be used on a level and stable surface.
- All fixings should be checked before the equipment is used.
- All literature relating to the use of the equipment should be retained for future reference.
- Recommended operating temperature: 5-40°C

Remove the safety key after use to prevent unauthorized treadmill operation.

2. IMPORTANT ELECTRICAL INFORMATION

WARNING!

- Route the power cord away from any moving part of the treadmill including the elevation mechanism and transport wheels.
- NEVER remove any cover without first disconnecting AC power.
- NEVER expose this treadmill to rain or moisture. This treadmill is not designed for use outdoors, near a pool, or in any other high humidity environment.
- This is a high-power item; please do not share the same outlet with other high power machines such as, fridges, air conditioning etc. Please choose an outlet exclusively for the machine and make sure the fuse is 10A.

3. IMPORTANT OPERATING INSTRUCTIONS

- Understand that changes in speed and incline do not occur immediately. Set your desired speed on the computer console and release the adjustment key. The computer will obey the command gradually.
- Use caution while participating in other activities while walking on your treadmill, such as watching television, reading, etc. These distractions may cause you to lose balance or stray from walking in the centre of the belt; which may result in serious injury.
- In order to prevent losing balance and suffering unexpected injury, never mount or dismount the treadmill while the belt is moving. This unit starts with at a very low speed. Simply standing on the belt during slow acceleration is proper after you have learned to operate this machine.
- Always hold on to handrail while making control changes.
- A safety key is provided with this machine. Remove the safety key will stop the walking belt immediately; the treadmill will shut off automatically. Inserting the safety key will reset the display.
- Do not use excessive pressure on console control keys. They are precision set to function properly with little finger pressure.
- Replace any defective components immediately. The machine must be kept out of use until repaired.

4. ASSEMBLY INSTRUCTIONS

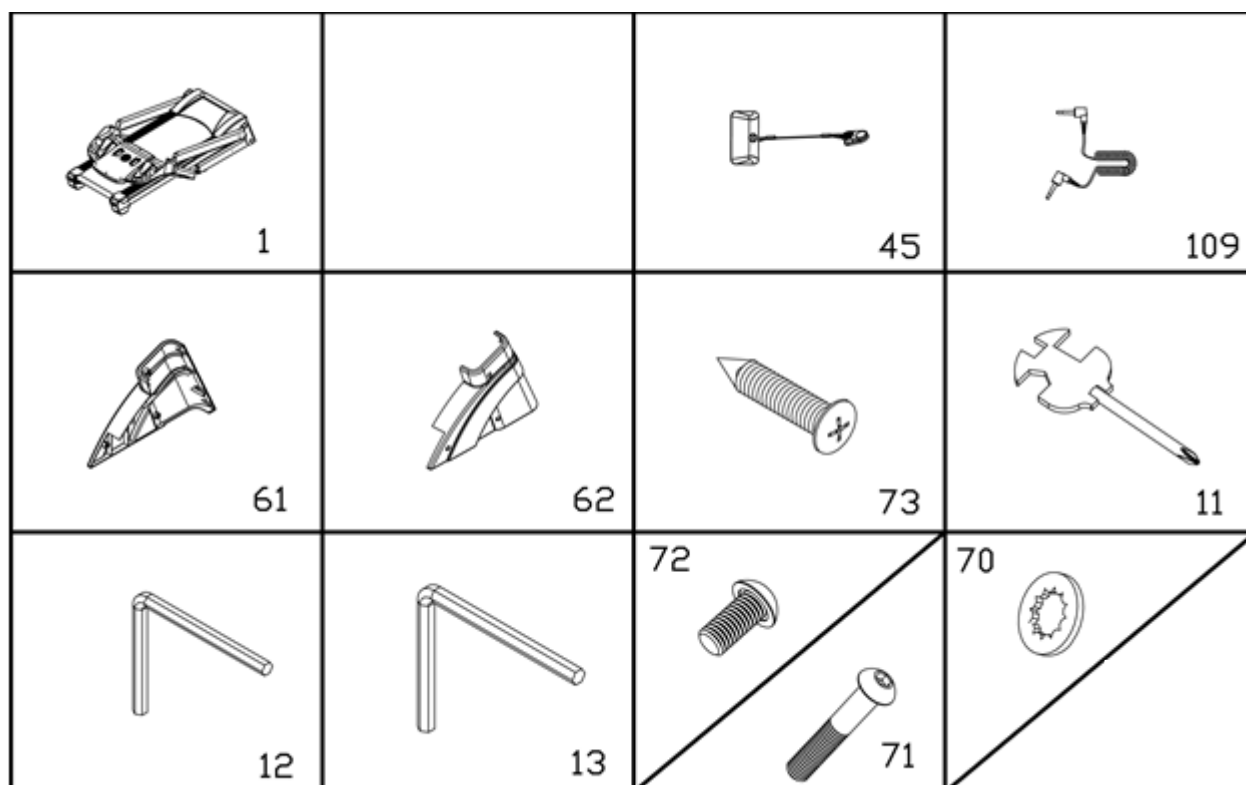

PART LIST

NO.	DES.	Specification	Qty	NO.	DES.	Specification	Qty
1	Main frame		1	62	Right base cover		1
5	Computer components		1				
				70	Lock washer	8	8
45	Safety key		1	72	Screw	M8*20	8
11	Allen Wrench	S=13、14、15	1	73	Screw	ST4.2*19	6
12	5#Allen Wrench	5mm	1	71	Screw	M8*55	2
13	6#Allen Wrench	6mm	1	109	MP3 wire		1
61	Left base cover		1				

ASSEMBLY TOOLS:

6#Allen Wrench 5mm 1pc

Wrench screw Driver S=13, 14, 15 1pc

Note: Do not connect power before completing assembly

STEP 1:

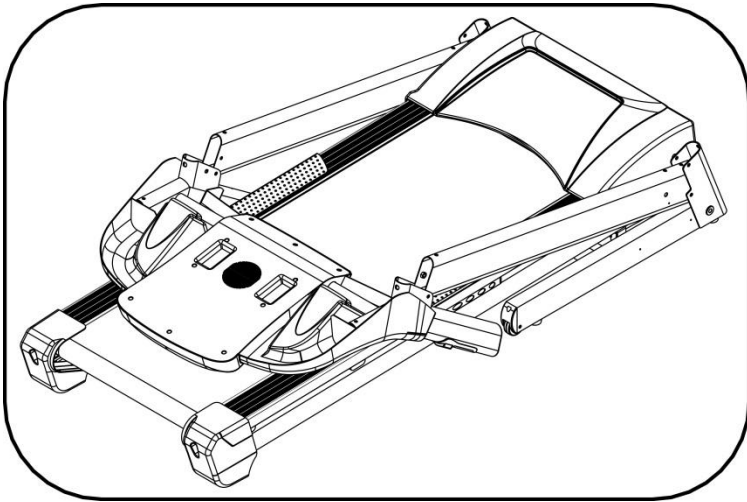

1. Open the carton
2. Extract the parts listed above
3. Place the Main Frame onto level ground

STEP 2:

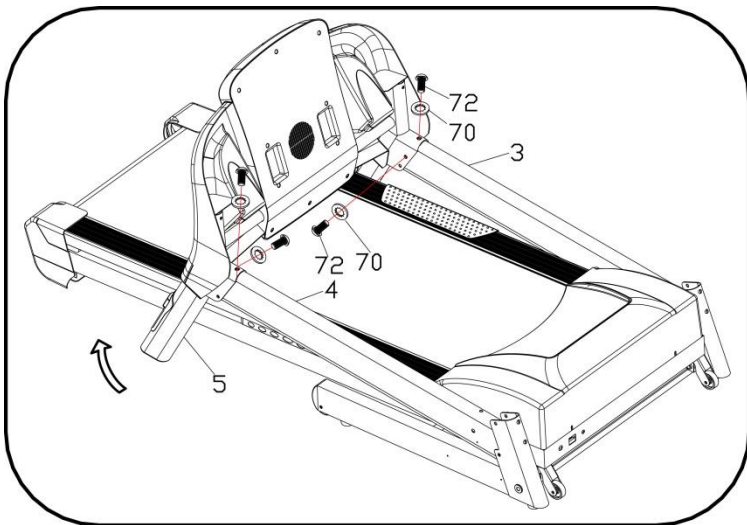

1. Move the display in the direction of the arrow in the diagram.
2. Do not damage the wire inside the right upright (4) to the wire.
3. Use 5#Allen Wrench, Screw M8*20 (72) and Lock washer (70) to secure Computer components (5) to the right upright (4). Repeat this for the left side.

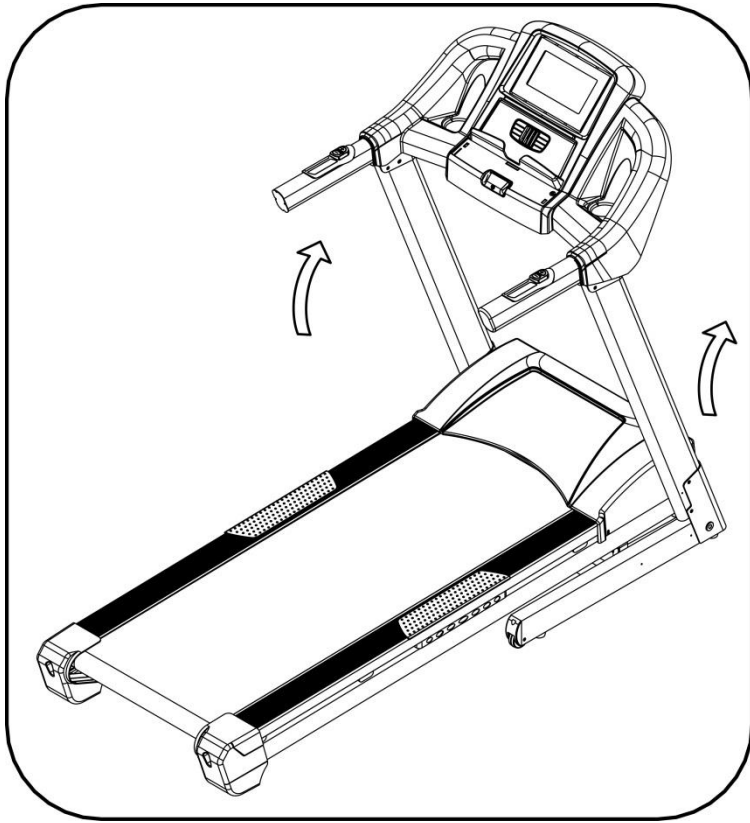

1. Erect the Upright Tubes in the direction of the arrows. Support the upright tubes with your hands to prevent them from falling down.

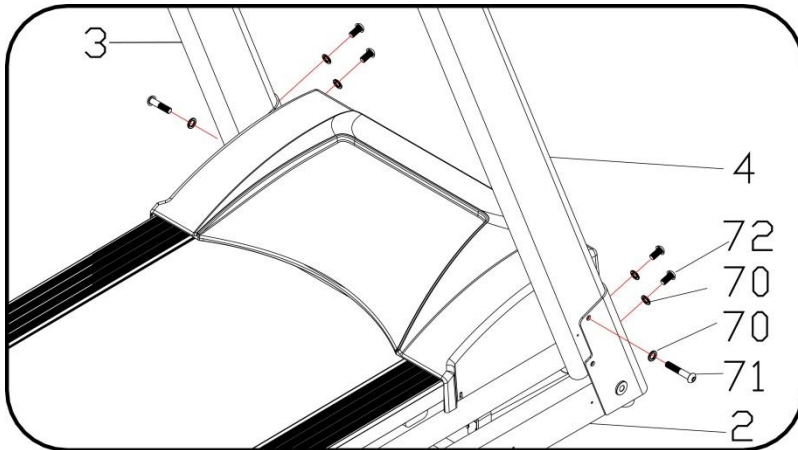

1. Use the 5# Allen wrench (12) to secure the right base frame with M8*55 bolt (71) and lock washer (70). Repeat this for the left side.

STEP 5:

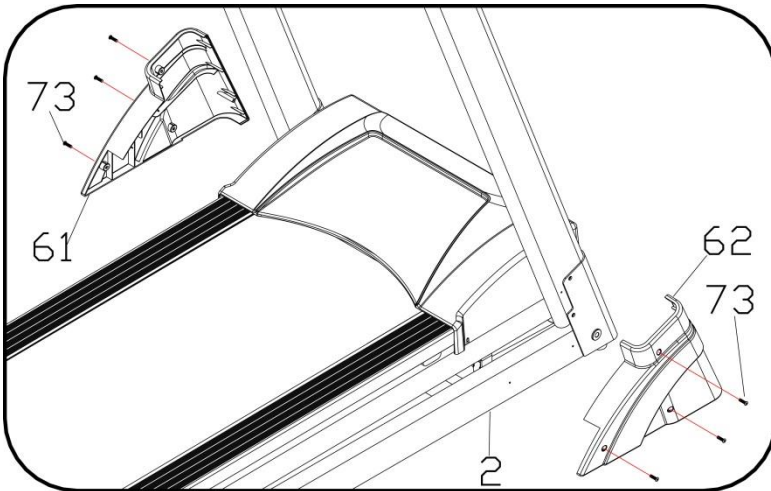

1. Using the Allen Wrench (11), attach left & right base cover (61) (62) with screw ST4.2*19 (73).

STEP 6:

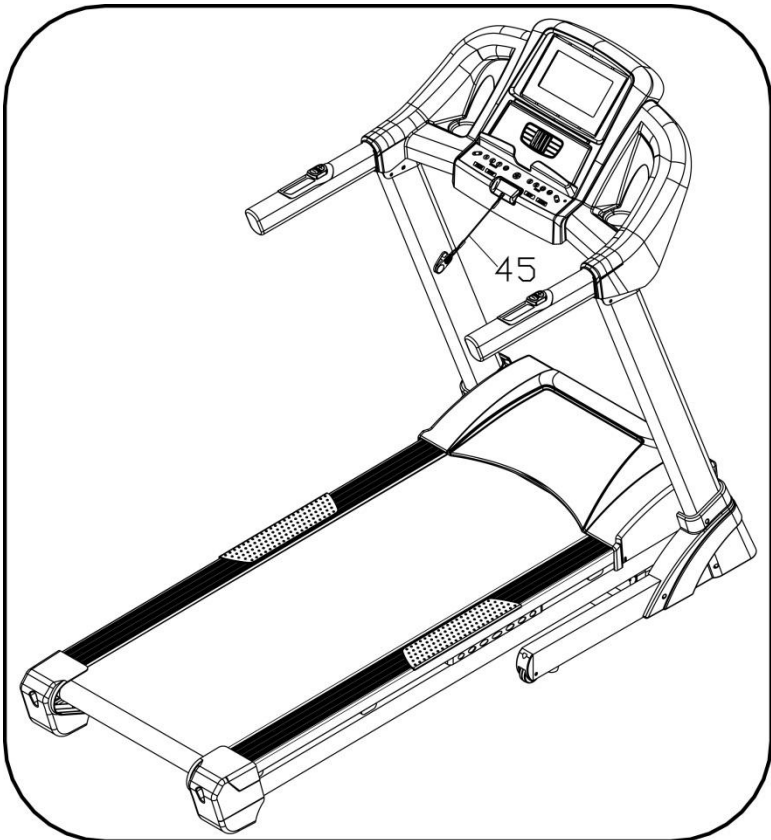

1. Tighten all the screw, then put safety key(45) on the computer.

5. FOLDING INSTRUCTIONS

Folding:

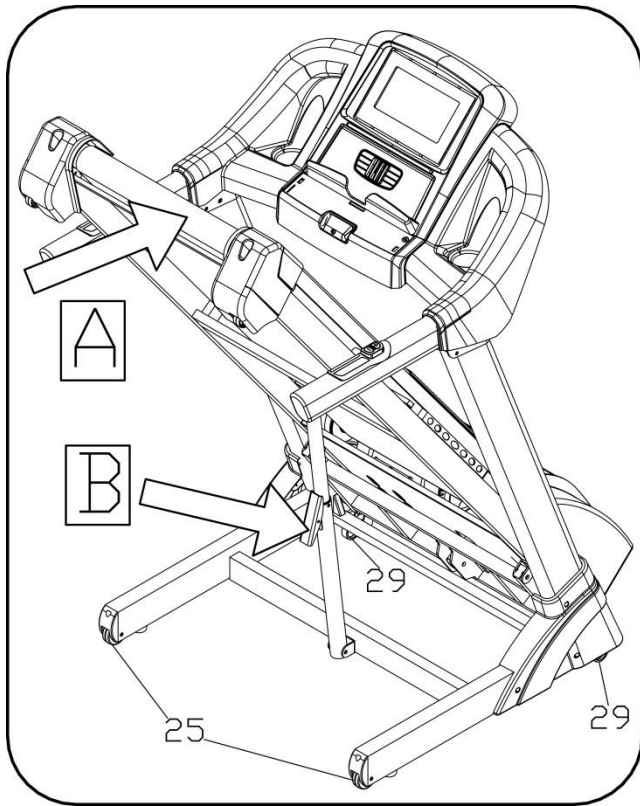

Erect the base frame using position (A) until you hear the click sound emitted when the air pressure bar (B) is locked into the round tube.

Unfolding:

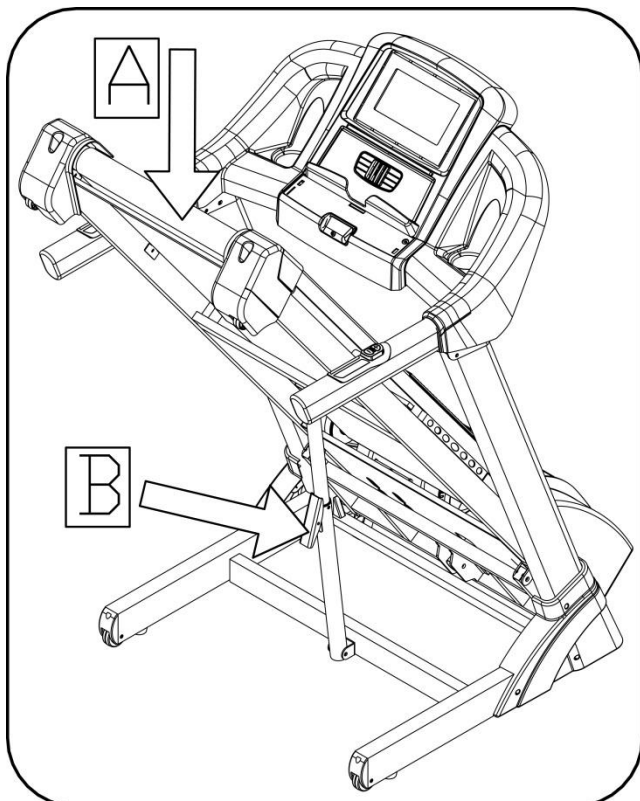

1. Whilst supporting position (A) with your hand, pull out the pin (B) with your right hand.
2. Maintain this pin position whilst gently pulling the base frame towards the ground. Let the base frame descend slowly to the ground.
3. The base frame will descend automatically. (Please keep people and any pets away the machine during descent)



6. OPERATION GUIDE



1. Window display, as shown on console:

PULSE:	Heart rate in bpm
TIME:	Shows time in h:min
DISTANCE:	Shows distance in km/h
CAL:	Shows calories in KCAL
LAPS:	Shows 400m laps
MATRIX CHART:	Rotates between speed and incline when in program mode
TRACK	Simulated 400m running track visible when in manual mode
INCLINE:	Shows incline level
SPEED:	Shows speed in km/h

2. Button functions:

'PROG'	Button to choose program. Cycles through: Manual, P1-P99
'MODE'	Button for countdown. Cycles through: Manual, time countdown, distance countdown, calorie countdown
'START'	Button to start. By pressing this button the treadmill will start with the lowest speed or speed by default program after a countdown of 3 seconds
'STOP'	Button to stop. By pressing this button during operation the treadmill will slow down slowly until a stop
'SPEED'	Speed +/- adjustment. Increases or decreases speed during operation. Sets parameter when stopped
'SPEED (5 8 12 15) '	Instant speed adjustment buttons
'INCLINE '	Incline adjustment up and down. Adjusts the incline gradient during operation. Sets parameter when stopped
'INCLINE (3 6 9 12) '	Instant incline adjustment buttons
	Speaker mute button
	Fan function switch button. Turns fan on/off
Left handlebar keys	Incline adjustment buttons
Right handlebar keys	Speed adjustment buttons

3. General operational procedure (manual)

1. Turn the power on
2. Attach the safety key
3. Press the start key

4. The LCD will display a 3 second countdown. Then the machine will begin to run at the lowest speed. Toggle speed and incline using buttons on the console or handlebars. Upon workout completion, press the STOP key.

4. Countdown Mode:

Press MODE button to cycle through time count down, distance count down, calories count down. Press SPEED buttons to adjust the data requested. Then press START button, front window display: 3—2—1, then start treadmill, the machine will run at 1 km/h, press SPEED and INCLINE buttons to adjust speed and gradient. When the window data counts down to 0 the machine will stop smoothly. You can press STOP or take off the safety key to stop running at any time.

5. Preset installed programs and “USER” programs:

Press “PROGRAM” button and the SPEED window will display P1-P99 to choose the program you like. The TIME window will then flash, press SPEED arrows to set desired exercise time.

The preset installed programs are divided into 20 sections with the time for each section is 1/20th of the total exercise time. Press the START button and the treadmill will start with the first section’s speed and equivalent gradient after a 3 second countdown. After completing the first section the treadmill will enter the next section automatically. Speed and incline will also be automatically adjusted to this section’s parameter. After all sections are complete the program will end and the treadmill will stop smoothly.

Press SPEED and INCLINE arrow buttons to adjust speed and incline gradient during the workout. When the program enters the next section it will adjust to the default program automatically. You can also press STOP or take off the safety key to stop running.

The Preset data is in the table below. After cycling through the programs using PROG and reaching P99, continue pressing PROG and the user defined programs: U1, U2, U3 will appear sequentially.

U1 is divided into 20 sections. Speed and incline for each segment are to be entered by the user. After setting all 20 segments, the time window will flash. Then you can set the desired time. Press start, then begin enter into user program. User programs can be saved even when powered off.

	Initial	Set initial value	Set range	Show range
TIME (Min.: Sec.)	0:00	30:00	10:00-99:00	0:00—99:59
SPEED(KM/H)	0.0	N/A	N/A	1.0—18.0

DISTANCE(KM)	0.00	1.0	0.5—99.00	0.00—99.99
PULSE (Times/Min.)	P	N/A	N/A	40—200
CALORIES(Kcal)	0	50	10—999	0—999
INCLINE	N	0	0-18	0-18

6. Body fat test:

Press the MODE button to enter the body fat test program. Press + or – to select sex, press MODE to confirm.

To enter age setting, press + or – to adjust age, press MODE to confirm.

To enter height setting, press + or – to adjust height, press MODE to confirm.

To enter weight setting, press + or – to adjust weight, press MODE to confirm.

Now the parameter window will display "-- -- --". Hold the pulse sensors for five seconds and it will display your body mass index (BMI).

Body fat index parameter table:

Parameter class	Default	Setting range	Remark
Sex	01 (Male)	01—02	01=Male 02= Female
Age	25 years	10—99 years	
Height	170 CM	100—240 CM	
Weight	70KG	20—150KG	

7. Heart rate test:

Hold the hand pulse sensors and the window will show your heartbeat after 5 seconds. In order to achieve the most accurate heart rate reading, please perform this test when the machine stopped and holding the sensors for no less than 30 seconds. This data is only for reference, and not to be used for medical purposes.

8. Safety function:

If the safety key is pulled off the window will display "SAFEKEY", the treadmill will emit a beeping sound, at this time machine cannot operate. After replacing the safety key the LCD window show the weight set up by last time, equipment reset, wait for enter command.

9. Sleep function:

When treadmill stopped, it will enter sleep function if no commands are entered within 10 minutes. Press the power key to wake the console and resume operation.

10. Heart Rate Control (HRC) Program List:

□ HRC programs have a maximum duration of 22 minutes.

• In standby mode, press the "Program" key until the DISTANCE window displays HP1, HP2 or HP3.

When in the HP1/HP2/HP3 display interface, press the start key to select a HRC program. The system will automatically recommend HRC parameters available to users.

Program Number	Functions	Default Parameters
HP1	Incline only	Maximum operating speed: 8.0km/h, 30 years of age, default target heart value of 150beats/min
HP2	Speed only	Maximum operating speed: 9.0km/h, 30 years of age, default target heart value of 160beats/min
HP3	Speed and incline	Maximum operating speed: 10.0km/h, 30 years of age, default target heart value of 170beats/min

• Press the "MODE" button to enter age setting. The time window will begin by showing the default age of 30. Use the INCLINE+/- or SPEED+/- buttons to set the correct age. The age range can be set between 15 to 80 years old.

• After age is selected, press "MODE". The system will recommend a suitable target heart rate, which will be displayed on screen for reference. You may also use the INCLINE+/- or SPEED+/- buttons to choose a desired target heart rate. The available option range is from 95 to 180beats/min.

• After setting desired age and target heart rate values, press START to start your workout or MODE to return to standby mode.

- During a HRC program, INCLINE+/- or SPEED+/- buttons will be available to adjust speed and incline. The system will also adjust speed and incline automatically to achieve the user's target heart rate value.

Scenario	Program Number	Result
Actual heart rate is less than target heart rate	HP1	Incline will increase by 1 level every 10 seconds, until the incline limit or the target heart rate is reached. (speed is controlled by the user)
	HP2	Speed will increase by 0.5km/h every 10 seconds, until the speed limit or the target heart rate is reached. (incline is controlled by the user)
	HP3	Speed will increase by 0.5km/h every 10 seconds, until the speed limit is reached. Once the maximum speed limit is reached, incline will increase by 1 level every 10 seconds, until the incline limit is reached.
Actual heart rate is greater than target heart rate	HP1	Incline will decrease by 1 level every 10 seconds, until minimum incline is reached or the target heart rate is reached. (speed is controlled by the user)
	HP2	Speed will decrease by 0.5km/h every 10 seconds, until minimum speed or the target heart rate is reached. (incline is controlled by the user)
	HP3	Incline will decrease by 1 level every 10 seconds, until the minimum incline is reached. Once the minimum incline is reached, speed will decrease by 0.5km/h every 10 seconds, until the minimum speed is reached. Values will stop changing once target heart rate is reached.

If the HRC program exceeds 20 minutes, the machine will automatically enter cool down mode. In cool down, incline will decrease to 0 and speed will lower by 0.5km/h every 10 seconds until speed reaches 4km/h or less. During the program, pressing STOP or disconnecting the safety key will end the workout.

Note: Heart rate control programs can only be used with a wireless chest strap. This must be worn just below the chest in direct contact with skin.

7. EXERCISE GUIDE

PLEASE NOTE: Before beginning any exercise program, consult your physician. This is important especially if you are over the age of 45 or individuals with pre-existing health problems.

The pulse sensors are not medical devices. Various factors, including the user's movement, may affect the accuracy of heart rate readings. The pulse sensors are intended only as an exercise aid in determining heart rate trends in general.

Exercising is great way to control your weight, improving your fitness and reduce the effect of aging and stress. The key to success is to make exercise a regular and enjoyable part of your everyday life.

The condition of your heart and lungs and how efficient they are in delivering oxygen via your blood to your muscles is an important factor to your fitness. Your muscles use this oxygen to provide enough energy for daily activity. This is called aerobic activity. When you are fit, your heart will not have to work so hard. It will pump a lot fewer times per minute, reducing the wear and tear of your heart.

So as you can see, the fitter you are, the healthier and greater you will feel.

Warm-up

Start each workout with 5 to 10 minutes of stretching and some light exercises. A proper warm-up increases your body temperature, heart rate and circulation in preparation for exercise. Ease into your exercise.

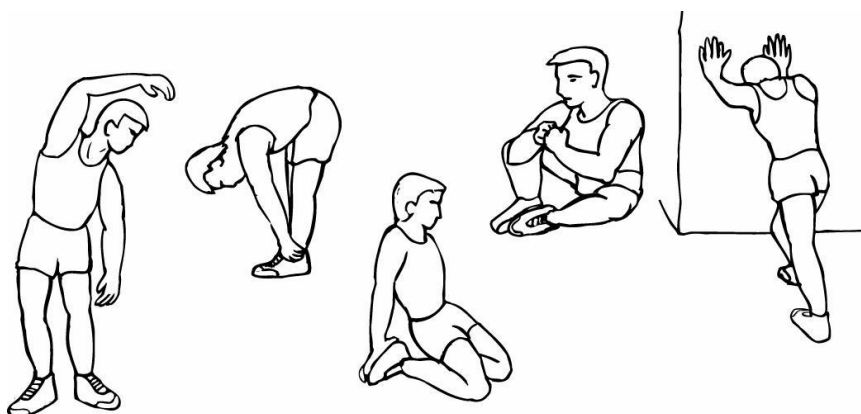

Training Zone Exercise

After warming up, increase the intensity to your desired exercise program. Be sure to maintain your intensity for maximum performance. Breathe regularly and deeply as you exercise.

Cool Down

Finish each workout with a light jog or walk for at least 1 minute. Then complete 5 to 10 minutes of stretching to cool down. This will increase the flexibility of your muscles and will help prevent post-exercise problems.

Workout Guidelines

TARGET ZONE

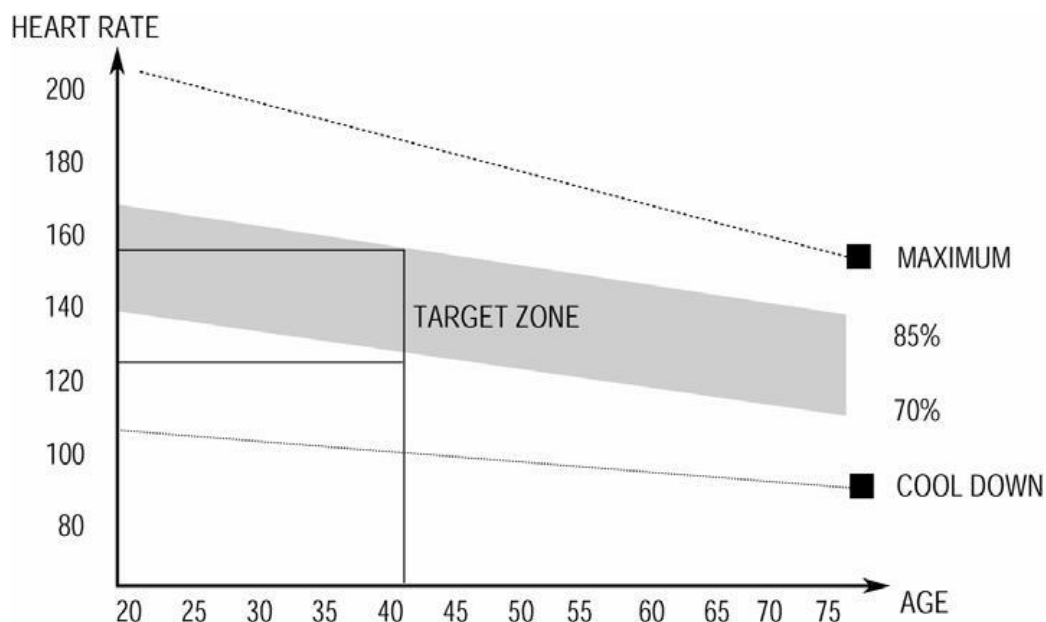

This is how your pulse should behave during general fitness exercise. Remember to warm up and cool down for a few minutes.

The most important factor here is the amount of effort you put in. The harder and longer you work, the more calories you will burn.

8. MAINTENANCE INSTRUCTIONS

Reasonable cleaning/lubricating should be made to extend the life time of this unit. Performance is maximized when the belt and mat are kept as clean as possible.

WARNING: THE MAT/DECK FRICTION MAY PLAY A MAJOR ROLE IN THE FUNCTION AND LIFE OF YOUR TREADMILL AND THAT IS WHY WE RECOMMEND YOU CONSTANTLY LUBRICATE THIS FRICTION POINT TO PROLONG THE USEFUL LIFE OF YOUR TREADMILL. FAILING TO DO THIS MAY VOID YOUR WARRANTY.

WARNING: UNPLUG POWER CORD BEFORE MAINTENANCE

WARNING: STOP TREADMILL BEFORE FOLDING

1. General Cleaning

- Use a soft, damp cloth to wipe the edge of the belt and the area between the belt edge and frame. A mild soap and water solution along with a nylon scrub brush will clean the top of the textured belt. This task should be done once a month. Allow to dry before using.
- On a monthly basis, vacuum underneath your treadmill to prevent dust build up. Once a year, you should remove the black motor shield and vacuum out dirt that may accumulate.

2. General Care

- Check parts for wear before use.
- Pay particular attention to the fixing knobs and make sure they are tight.
- Always replace the mat if worn and any other defective parts.
- If in doubt do not use the treadmill and contact us.

TAKE CARE TO PROTECT CARPETS AND FLOOR in case of leakages. This product is a machine that contains moving parts which have been greased / lubricated and could leak.

3. Belt/Deck/Roller Lubrication

The mat/deck friction may play a major role in the function and life of your treadmill and that is why we recommend you constantly lubricate this friction point to prolong the useful life of your treadmill. You should apply lubrication after approximately the first 30 hours of operation. We recommend lubrication of the deck according to the following timetable:

- Light use (less than 3 hours per week) every 6 months
- Medium use (3-5 hours a week) every 3 months
- Heavy use (more than 5 hours per week) every 6-8 weeks

See below procedures for lubricating:

1. Use a soft, dry cloth to wipe the area between the belt and deck.
2. Spread lubricant onto the inside surface of belt and deck evenly (make sure the machine is turned off and power is disconnected).

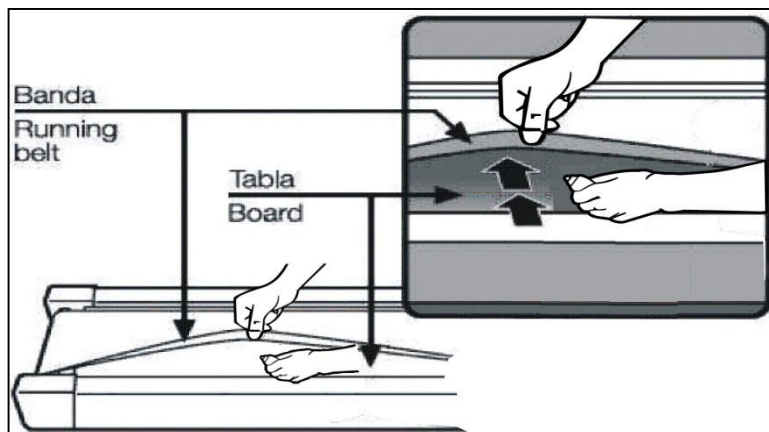

3. Periodically lubricate the front and rear rollers to keep them at their peak performance. If the treadmill belt/deck/roller is kept reasonably clean it is possible to expect over 1200 hours before relubricating is necessary.

Video Tutorial Available at:
<http://youtu.be/cP9NtFHfWlc>

Lifespan Fitness Channel:
<http://www.youtube.com/user/treadmillsvideos>

4. How to check the running mat for proper lubrication:

1. Disconnect the main power supply.
2. Fold the treadmill up into the storage position.
3. Feel the underside surface of the running mat.

If the surface is slick when touched, then no further lubrication is needed.

If the surface is dry to the touch, apply a suitable silicone lubricant.

We recommend that you use a silicone based spray to lubricate your Lifespan treadmill. This can be purchased directly from us or any hardware store.

5. Adjusting the Running Belt

Place treadmill on a level surface. Run treadmill at approximately 4km/h, checking the running condition.

If the belt has drifted to the **right**:

Whilst the treadmill is running at 4km/h, carefully turn the **right** adjusting bolt 1/4 turn **clockwise**. Then monitor treadmill until the belt centers. Repeat until the belt correctly centers.

See *Picture A*

If you have over adjusted the belt and it drifts to the right, carefully turn the **right** adjusting bolt **anticlockwise** until the belt centers.

If the belt has drifted to the **left**:

Whilst the treadmill is running at 4km/h, carefully turn the **left** adjusting bolt 1/4 turn **clockwise**. Then monitor treadmill until the belt centers. Repeat until the belt correctly centers.

See *Picture B*

If you have over adjusted it, carefully turn the **left** adjusting bolt **anticlockwise** and until the belt centers.

To adjust the **tightness** of the belt:

Turn the treadmill off. Turn both the left and right adjusting bolts 1/4 turn clockwise. Repeat until the belt correctly tightens.

See *Picture C*

If the belt is over tightened, simply do the opposite to loosen.

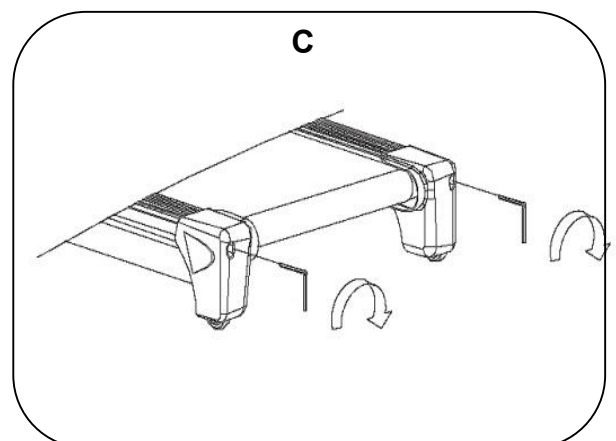
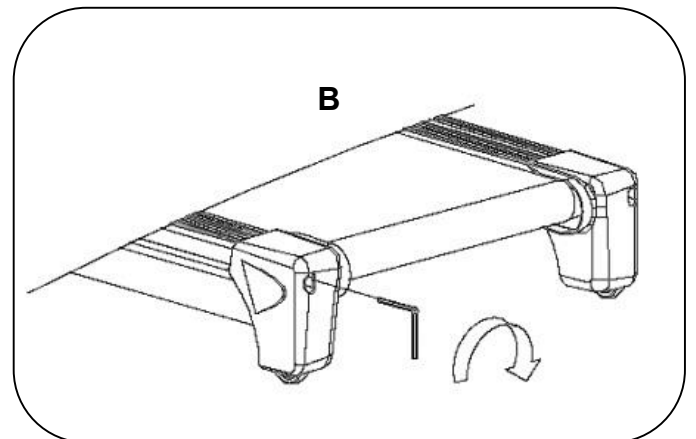
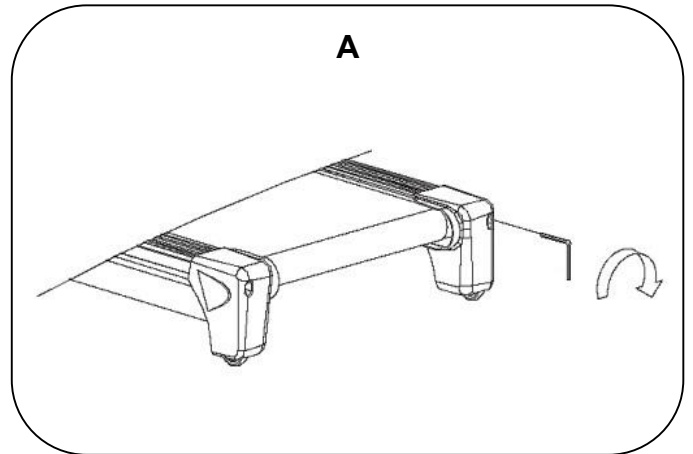

NOTE: When properly tightened, you should be able to peel the very edge of the side of the belt up approximately 2 inches. However this is a rough reference and not all treadmills are the same. Some treadmills that have longer belts may give different measurements for correct belt tightness.

Simply, if the belt begins to slip during use, this is an indication that the belt still needs tightening.

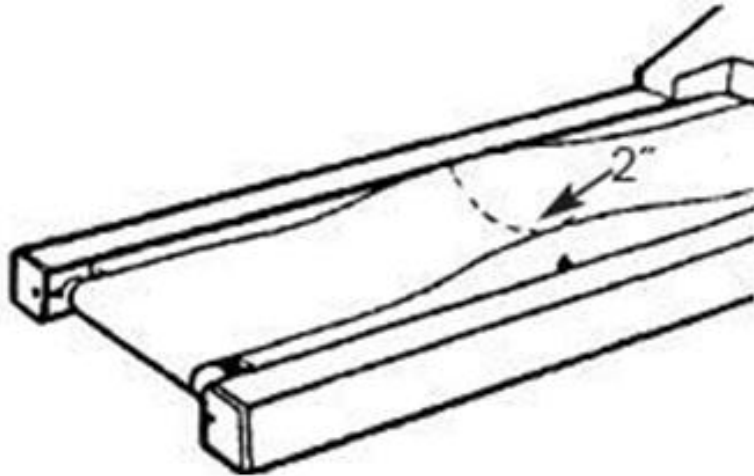

Video Tutorial Available at:
<http://youtu.be/vlsamTSwA>

Lifespan Fitness Channel:
<http://www.youtube.com/user/treadmillsvideos>

6. Replacing Motor Brushes

After extended use, the motor brushes in your treadmill motor will wear down, and this can lead to motor failure. It is important that you maintain your motor by replacing the brushes on either side of the motor when they are worn down. We recommend that you check your motor every 1000 hours of usage.

IMPORTANT: Before beginning the replacement of your motor brush, ensure that the treadmill is off and unplugged from the electrical socket.

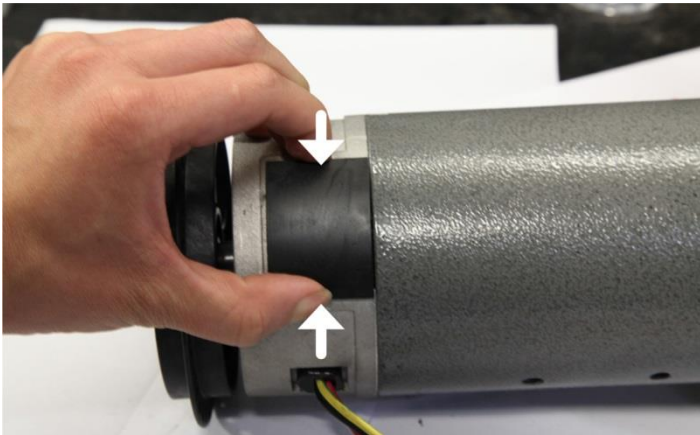

1. Remove the cover from the motor by squeezing it from the sides.

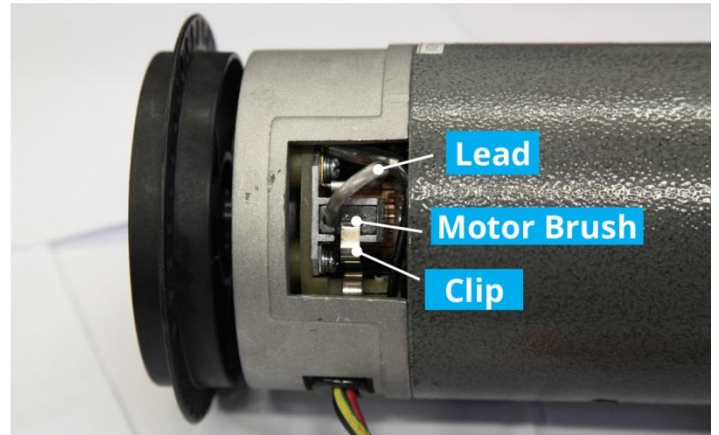

2. You'll find the motor brush held in with a clip, with the lead plugged in.

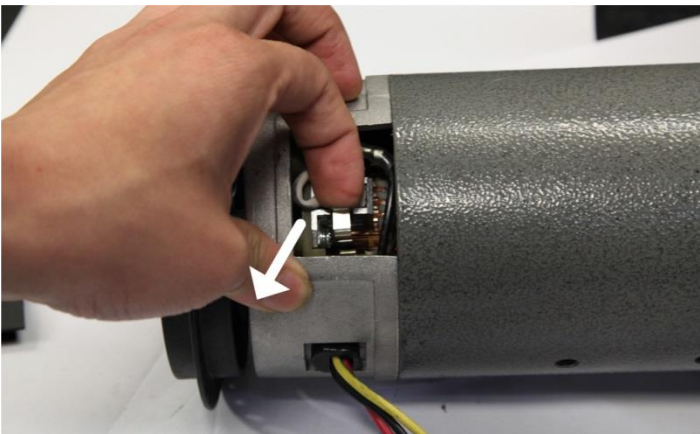

3. Pull the clip out from its position.

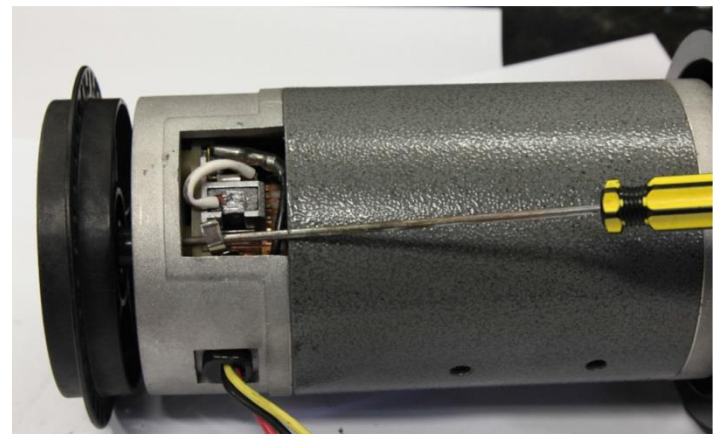

4a. Hold the clip out of the way with a screwdriver or similar object. Keep the screwdriver in this position until step 9.

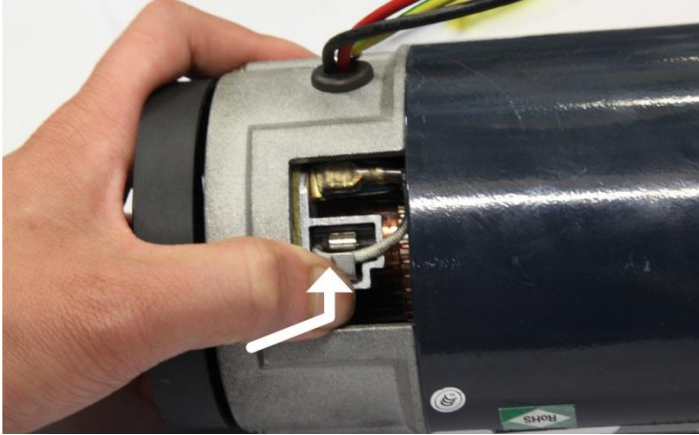

4b. Some treadmill motors may use a push clip instead. In this case, gently push the clip inwards and then up to release it from its latch.

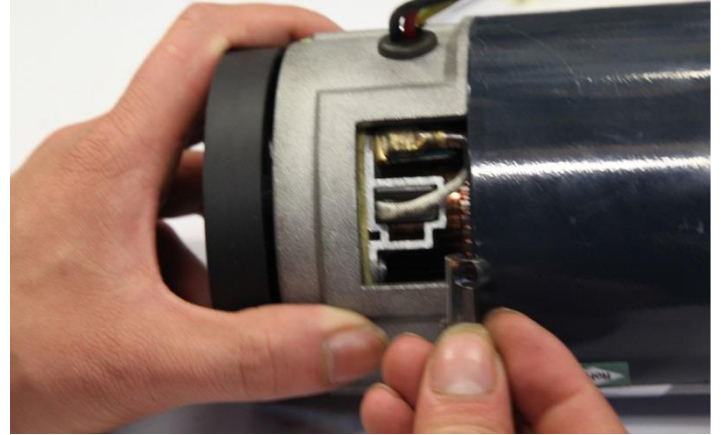

4c. Remove the clip, noting the direction in which it was originally placed, and put it safely aside.

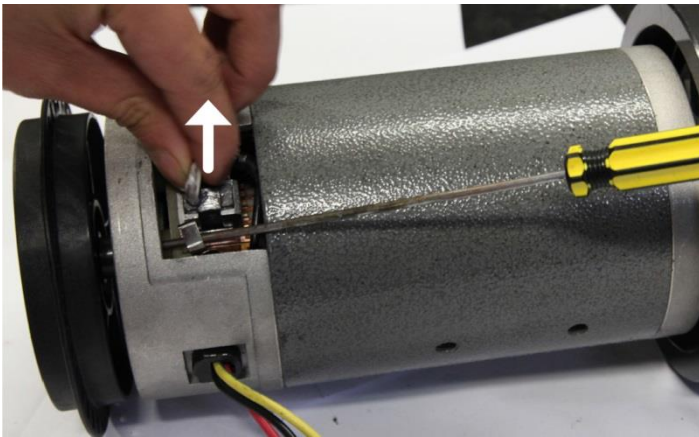

5. Slide the motor brush out from its slot. If the brush is shorter than 2cm on the longest side, you will need to replace both brushes.

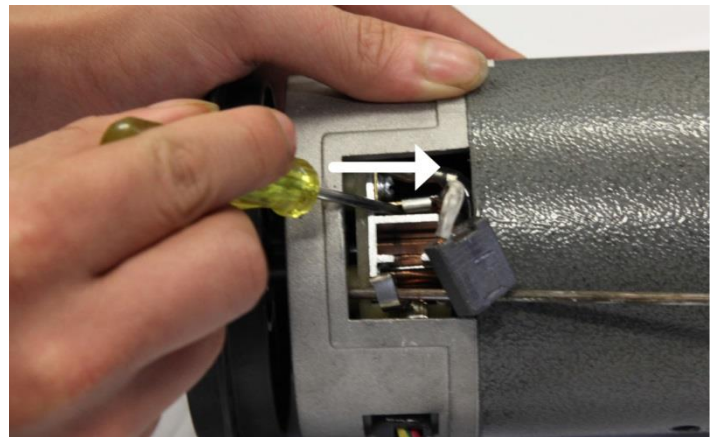

6. Slide the motor brush lead off the terminal using another small screwdriver or needle-nosed pliers.

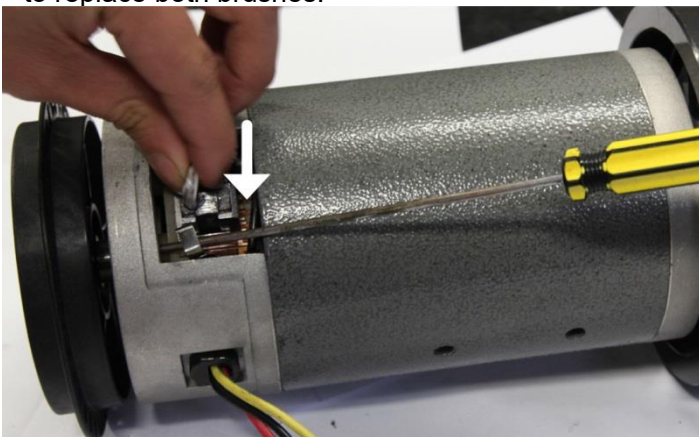

7. Plug the new motor brush lead into the terminal.

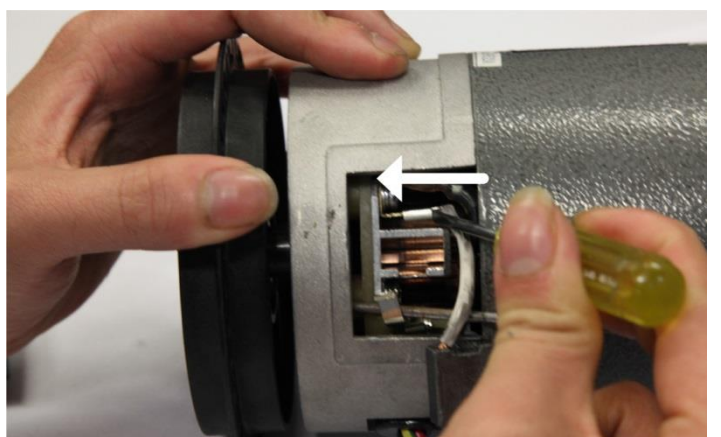

8. Slide the new motor brush into the slot.

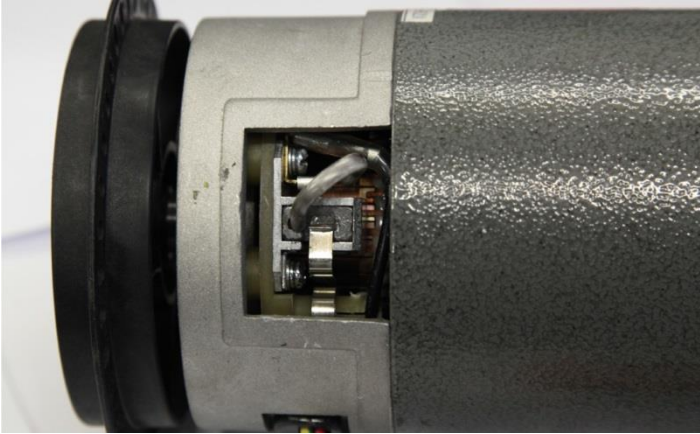

9a. Release the clip back into its position.

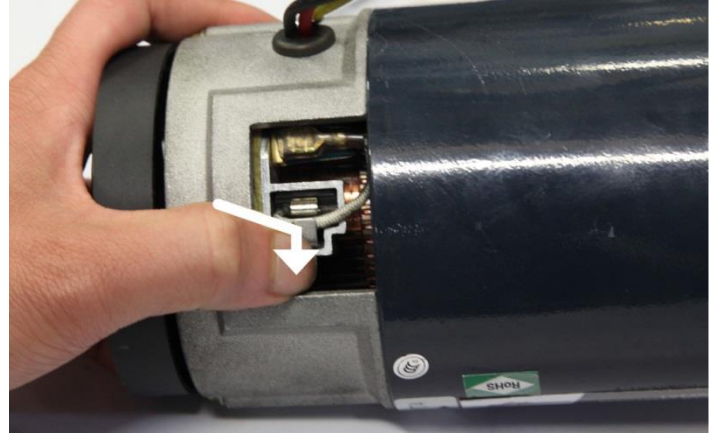

9b. If your motor uses a push clip, replace the push clip by pushing it inwards and then down so that it engages the catch.

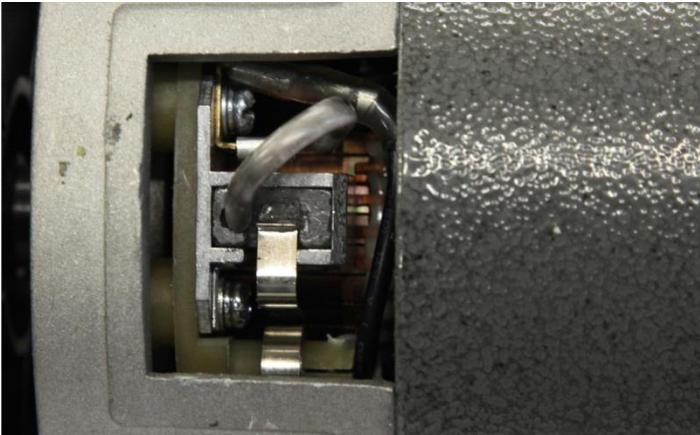

10. Check that the motor brush is held firmly in place by the clip, and that the lead is plugged securely onto the terminal.

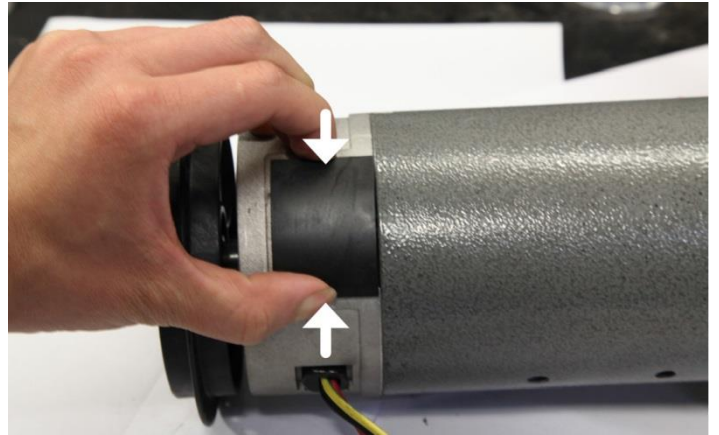

11. Replace the motor cover. Repeat steps 1-15 for the second brush located on the opposing side of the motor.

12. You have now successfully replaced the motor brushes. We also recommend that you remove any dirt and dust from your treadmill motor fan using a vacuum cleaner before replacing the cover.

9. EXPLODED DIAGRAM

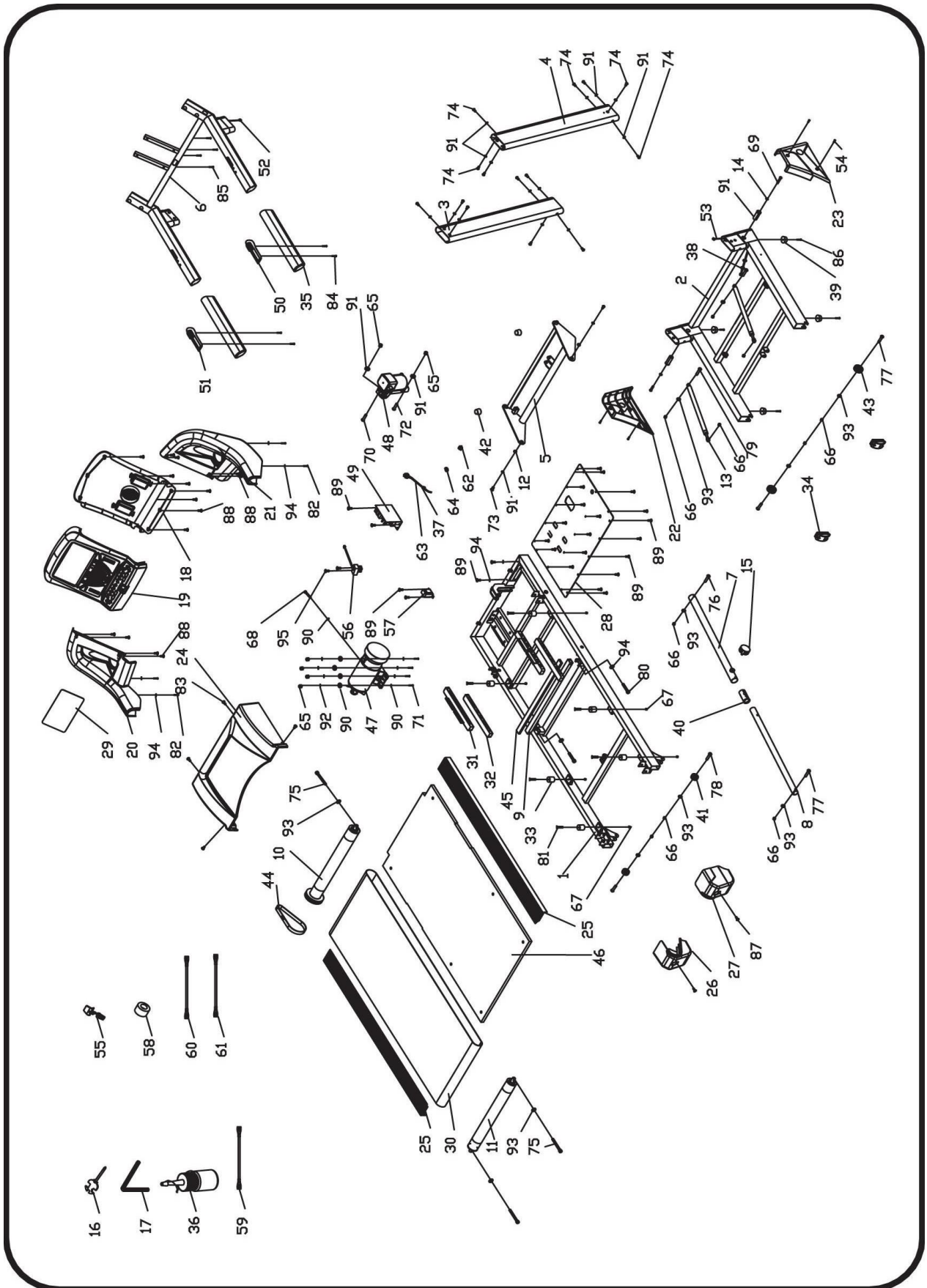

10. PARTS LIST

No.	Description	Spec	Qty.	No.	Description	Spec	Qty.
1	Main frame		1	38	Circle plug B		2
2	Base frame		1	39	Foot pad		4
3	Left upright		1	40	Small tube bushing		1
4	Right upright		1	41	Adjustable wheel		2
5	Incline motor bracket		1	42	Cone-shape cushion pad		2
6	Computer bracket		1	43	Transportation wheel		2
7	Adjustable tube bracket		1	44	Drive belt		1
8	Adjustable bar		1	45	EVA pad		1
9	Stiffened tube for running board		1	46	Running board		1
10	Front roller		1	47	DC motor group		1
11	Rear roller		1	48	Incline motor		1
12	Casing pipe		2	49	Control circuit board		1
13	Cylinder		2	50	Hand pulse with speed button		1
14	Roll casing pipe		2	51	Hand pulse with incline button		1
15	Flexible pin		1	52	Computer up wire		1
16	Allen wrench	S=13、 14、 15	1	53	Computer bottom wire		1
17	6#Allen wrench	6mm	1	54	Screw	ST4.2*19	4
18	Computer bottom cover		1	55	Safety key		1
19	Computer panel		1	56	Light sensor		1
20	Left handrail		1	57	Transformer		1
21	Right handrail		1	58	Magnetic Ring		1
22	Left base cover		1	59	AC Single line		1
23	Right base cover		1	60	Blue single line		1
24	Motor cover		1	61	Brown single line		1
25	Side rail		2	62	Square rocker switch		1
26	Left back end cover		1	63	Standard power wire		1
27	Right back end cover		1	64	Overload protector		1
28	Bottom plate		1	65	I type hexagon nuts	M10	6
29	Acrylic plate		1	66	I type hexagon nuts	M8	10
30	Foot pad for side rail		1	67	I type hexagon nuts	M6	8
31	Long cushion pad 1		2	68	Hexagon bolt	M10*80	1
32	Long cushion pad 2		2	69	Hexagon bolt	M10*60	2
33	Cushion pad		6	70	Hexagon bolt	M10*55	1

34	Roller wheel cover		2	71	Hexagon bolt	M10*45	4
No.	Description	Spec	Qty.	No.	Description	Spec	Qty.
35	Jacket		2	72	Hexagon bolt	M10*42	1
				73	Hexagon bolt	M10*20	2
37	Power wire buckle		1	74	Hexagon bolt	M10*15	14
75	Hexagon socket cap screw	M8*65	3	86	screws	ST4.8*25	4
76	Hexagon bolt	M8*55	1	87	pan head screws	ST4.8*19	4
77	Hexagon bolt	M8*48	3	88	pan head screws	ST4.2*15	18
78	Hexagon bolt	M8*40	2	89	Screw	ST4.2*12	26
79	Hexagon bolt	M8*25	2	90	Flat washer	10	7
80	pan head screw	M6*45	2	91	Lock washer	10	20
81	Hexagon screw	M6*25	6	92	Spring lock washer	10	4
82	pan head screw	ST4.2*15	4	93	Lock washer	8	13
83	pan head screw	M5*8	4	94	Lock washer	6	9
84	pan head tapping screws	ST4.2*80	4	95	pan head screws	ST2.9*6.5	2
85	pan head tapping screws	ST4.2*30	4				4

11. WARRANTY

AUSTRALIAN CONSUMER LAW

Many of our products come with a guarantee or warranty from the manufacturer. In addition, they come with guarantees that cannot be excluded under the Australian Consumer Law. You are entitled to a replacement or refund for a major failure and compensation for any other reasonably foreseeable loss or damage.

You are entitled to have the goods repaired or replaced if the goods fail to be of acceptable quality and the failure does not amount to a major failure. Full details of your consumer rights may be found at www.consumerlaw.gov.au

Please visit our website to view our full warranty terms and conditions:

<http://www.lifespanfitness.com.au/warranty-repairs>

Warranty and Support:

Please email us at support@lifespanfitness.com.au for all warranty or support issues.

For all warranty or support related enquiries an email must be sent before contacting us via any other means.

TROUBLE SHOOTING

CODE	REASON	SOLUTION
E01	Message failure between computer and bottom control board	<ol style="list-style-type: none"> 1. Check the computer and bottom control board wire connection; 2. Check if IC on bottom control board is loose, reset the IC 3. Power on bottom control board, if there is an error, change the bottom control board
E02	Burst clash	<ol style="list-style-type: none"> 1. Check that the power voltage is suitable, if not, use correct power voltage; 2. Check if the bottom control is burnt out; if yes - replace; then reconnect the motor wire.
E03	No sensor signal	<ol style="list-style-type: none"> 1. Check that all sensor wires are in good condition, replace if damaged 2. Check the speed sensor, replace if damaged 3. Check the motor condition and wiring
E05	Current overload protection	<ol style="list-style-type: none"> 1. Over rated loaded or the motor is stuck, causing excessive current, machine will start self-protection system. Adjust the machine and restart; 2. Check if there is irregular noise coming from the motor or if the motor / bottom control board is burnt out; if burnt out, change to a good motor and bottom control; remember to use the correct voltage.
	Motor not starting after pressing START	Probable Issues: <ol style="list-style-type: none"> 1. Broken motor 2. Damaged safety wire 3. Motor wiring not connected well 4. IGBT on bottom control board is burnt out

Hand Pulse Technology

Lifespan Fitness Treadmills come equipped with hand pulse sensors which are used to pick up tiny EKG/ECG signals that run through the body when your heart beats. These electrical EKG/ECG signals are very small and that they must be amplified 1000 times to make the signal useful for the computer to display your pulse.

To ensure proper operation:

- The user must maintain good, consistent contact on all four sensors
- The users skin cannot be too dry or too wet

Other factors that could affect the reading:

- Change of grip on the sensors (during slow pace walking and up to running)
- Tightening of hand muscles will produce small electrical signals
- Static electricity charges from the air or from walking on the treadmill

EKG/ECG Sensors may filter through actual EKG/ECG signals and “Noise” factors that may affect the reading. This will cause the pulse reading to be delayed and will take longer to update the display as the heart rate changes. Too much noise will create an incorrect reading. Medical conditions or having no electrical signal in the hands are other factors that may affect pulse readings as well.

These are limitations of hand pulse technology and even the most expensive systems (which can cost upwards of \$3,000) used in hospitals have the same problems. The difference is that a patient in a hospital is not running on a treadmill. Hand pulse technology works well on stationary exercise machines like bikes and even elliptical cross trainers but are not perfect on a treadmill. We offer treadmills with a wireless heart rate receiver which may be a more accurate option.

To test if your hand pulse sensors are working up to specification, hold them while standing on the side step rails, not walking, and see if the reading is more in line with what you would expect. This will eliminate the movement and static electricity factors. If your hands are dry, then wet them slightly (saliva works as a great conductor if this doesn't bother you).

For more information, please contact our Lifespan Technical Support Department

www.lifespanfitness.com.au

support@lifespanfitness.com.au

12. PRESET PROGRAM LIST

TIME		Setting time/20= interval running time																			
		1	2	3	4	5	6	7	8	9	10	11	12	13	14	15	16	17	18	19	20
P01	SPEED	2	3	3	4	5	3	4	5	5	3	4	5	4	4	4	2	3	3	5	3
	INCLINE	1	1	2	2	2	3	3	3	2	2	1	2	2	1	1	3	3	2	2	2
P02	SPEED	2	4	4	5	6	4	6	6	6	4	5	6	4	4	4	2	2	5	4	2
	INCLINE	1	2	2	2	2	3	3	2	2	2	2	2	3	3	3	4	4	3	2	2
P03	SPEED	2	4	4	6	6	4	7	7	7	4	7	7	4	4	4	2	4	5	3	2
	INCLINE	2	3	3	2	2	3	3	3	2	2	2	2	4	4	4	6	6	3	2	2
P04	SPEED	3	5	5	6	7	7	5	7	7	8	8	5	9	5	5	6	6	4	4	3
	INCLINE	2	3	3	2	2	3	3	3	2	2	2	2	4	4	4	6	6	3	2	2
P05	SPEED	2	4	4	5	6	7	7	5	6	7	8	8	5	4	3	3	6	5	4	2
	INCLINE	3	3	3	4	4	5	5	5	4	4	4	4	5	5	3	3	3	2	2	2
P06	SPEED	2	4	4	4	5	6	8	8	6	7	8	8	6	4	4	2	5	4	3	2
	INCLINE	3	5	5	5	4	4	4	3	3	3	3	4	4	4	3	3	3	4	3	2
P07	SPEED	2	3	3	3	4	5	3	4	5	3	4	5	3	3	3	6	6	5	3	3
	INCLINE	4	4	4	4	3	3	6	6	6	7	7	8	8	9	9	6	6	5	4	4
P08	SPEED	2	3	3	6	7	7	4	6	7	4	6	7	4	4	4	2	3	4	4	2
	INCLINE	4	5	5	5	6	6	6	7	8	9	9	9	10	10	10	12	12	8	6	3
P09	SPEED	2	4	4	7	7	4	7	8	4	8	9	9	4	4	4	5	6	3	3	2
	INCLINE	5	5	5	6	6	6	4	4	6	6	5	5	8	8	9	9	9	7	4	2
P10	SPEED	2	4	5	6	7	5	4	6	8	8	6	6	5	4	4	2	4	4	3	3
	INCLINE	5	6	6	6	7	5	8	8	4	4	4	5	5	8	8	10	10	8	6	3
P11	SPEED	2	5	8	10	7	7	10	10	7	7	10	10	5	5	9	9	5	5	4	3
	INCLINE	4	5	3	2	6	6	2	2	2	2	2	4	5	6	3	2	5	5	2	0
P12	SPEED	3	4	9	9	5	9	5	8	5	9	7	5	5	7	9	9	5	7	6	3
	INCLINE	1	2	3	2	3	5	5	0	0	2	3	5	7	3	3	5	6	5	3	3
P13	SPEED	3	6	7	5	9	9	7	5	5	7	9	5	8	5	9	5	9	9	4	3
	INCLINE	3	3	5	6	5	3	3	7	5	3	2	0	0	5	5	3	2	3	2	1
P14	SPEED	2	2	4	5	6	5	4	3	2	1	2	3	4	5	6	5	4	3	2	1
	INCLINE	4	4	4	4	3	3	6	6	6	7	7	8	8	9	9	6	6	5	4	4
P15	SPEED	2	4	6	8	6	6	4	4	2	2	2	4	6	8	6	6	4	4	2	2
	INCLINE	3	3	3	4	4	5	5	5	4	4	4	4	5	5	3	3	3	2	2	2
P16	SPEED	2	4	6	8	10	8	6	4	2	2	2	4	6	8	6	6	4	4	2	2
	INCLINE	5	5	5	6	6	6	4	4	6	6	5	5	8	8	9	9	9	7	4	1
P17	SPEED	2	2	6	6	8	10	6	6	2	2	2	2	6	6	8	10	6	6	2	2
	INCLINE	4	5	5	5	6	6	6	7	8	9	9	9	10	10	10	12	12	8	6	3
P18	SPEED	2	3	4	5	2	3	4	5	3	2	2	3	4	5	2	3	4	5	3	2
	INCLINE	4	4	4	4	3	3	6	6	6	7	7	8	8	9	9	6	6	5	3	2
P19	SPEED	2	4	6	2	4	6	2	4	6	2	2	4	6	2	4	6	2	4	6	2
	INCLINE	3	5	5	5	4	4	4	3	3	3	3	4	4	4	3	3	3	4	3	2
P20	SPEED	1	3	4	5	6	5	4	3	2	1	1	3	4	5	6	5	4	3	2	1
	INCLINE	3	3	3	4	4	5	5	5	4	4	4	4	5	5	3	3	3	2	2	2

P21	SPEED	2	3	3	4	5	3	4	5	5	3	4	5	4	4	4	2	3	3	5	3
	INCLINE	1	1	2	2	2	3	3	3	2	2	1	2	2	1	1	3	3	2	2	2
P22	SPEED	2	4	4	5	6	4	6	6	6	4	5	6	4	4	4	2	2	5	4	2
	INCLINE	1	2	2	2	2	3	3	2	2	2	2	2	3	3	3	4	4	3	2	2
P23	SPEED	2	4	4	6	6	4	7	7	7	4	7	7	4	4	4	2	4	5	3	2
	INCLINE	2	3	3	2	2	3	3	3	2	2	2	2	4	4	4	6	6	3	2	2
P24	SPEED	3	5	5	6	7	7	5	7	7	8	8	5	9	5	5	6	6	4	4	3
	INCLINE	2	3	3	2	2	3	3	3	2	2	2	2	4	4	4	6	6	3	2	2
P25	SPEED	2	4	4	5	6	7	7	5	6	7	8	8	5	4	3	3	6	5	4	2
	INCLINE	3	3	3	4	4	5	5	5	4	4	4	4	5	5	3	3	3	2	2	2
P26	SPEED	2	4	4	4	5	6	8	8	6	7	8	8	6	4	4	2	5	4	3	2
	INCLINE	3	5	5	5	4	4	4	3	3	3	3	4	4	4	3	3	3	4	3	2
P27	SPEED	2	3	3	3	4	5	3	4	5	3	4	5	3	3	3	6	6	5	3	3
	INCLINE	4	4	4	4	3	3	6	6	6	7	7	8	8	9	9	6	6	5	3	3
P28	SPEED	2	3	3	6	7	7	4	6	7	4	6	7	4	4	4	2	3	4	4	2
	INCLINE	4	5	5	5	6	6	6	7	8	9	9	9	10	10	10	12	12	8	6	3
P29	SPEED	2	4	4	7	7	4	7	8	4	8	9	9	4	4	4	5	6	3	3	2
	INCLINE	5	5	5	6	6	6	4	4	6	6	5	5	8	8	9	9	9	7	4	2
P30	SPEED	2	4	5	6	7	5	4	6	8	8	6	6	5	4	4	2	4	4	3	3
	INCLINE	5	6	6	6	7	5	8	8	4	4	4	5	5	8	8	10	10	8	6	3
P31	SPEED	2	5	8	10	7	7	10	10	7	7	10	10	6	6	9	9	5	5	4	3
	INCLINE	4	5	3	2	6	6	2	2	2	2	2	4	5	6	3	2	5	5	2	0
P32	SPEED	3	4	9	9	5	9	5	8	5	9	7	5	5	7	9	9	5	7	6	3
	INCLINE	1	2	3	2	3	5	5	0	0	2	3	5	7	3	3	5	6	5	3	3
P33	SPEED	3	4	9	9	5	9	5	8	5	9	7	5	5	7	9	9	5	7	6	3
	INCLINE	1	2	3	2	3	5	5	0	0	2	3	5	7	3	3	5	6	5	3	3
P34	SPEED	2	2	4	5	6	5	4	3	2	1	2	3	4	5	6	5	4	3	2	1
	INCLINE	1	1	1	1	1	1	1	1	1	1	1	1	1	1	1	1	1	1	1	1
P35	SPEED	2	4	6	8	6	6	4	4	2	2	2	4	6	8	6	6	4	4	2	2
	INCLINE	1	1	1	1	1	1	1	1	1	1	1	1	1	1	1	1	1	1	1	1
P36	SPEED	2	4	6	8	10	8	6	4	2	2	2	4	6	8	6	6	4	4	2	2
	INCLINE	5	5	5	6	6	6	4	4	6	6	5	5	8	8	9	9	9	7	4	2
P37	SPEED	2	2	6	6	8	10	6	6	2	2	2	2	6	6	8	10	6	6	2	2
	INCLINE	4	5	5	5	6	6	6	7	8	9	9	9	10	10	10	12	12	8	6	3
P38	SPEED	2	3	4	5	2	3	4	5	3	2	2	3	4	5	2	3	4	5	3	2
	INCLINE	4	4	4	4	3	3	6	6	6	7	7	8	8	9	9	6	6	5	3	3
P39	SPEED	2	4	6	2	4	6	2	4	6	2	2	4	6	2	4	6	2	4	6	2
	INCLINE	3	5	5	5	4	4	4	3	3	3	3	4	4	4	3	3	3	4	3	2
P40	SPEED	1	3	4	5	6	5	4	3	2	1	1	3	4	5	6	5	4	3	2	1
	INCLINE	3	3	3	4	4	5	5	5	4	4	4	4	5	5	3	3	3	2	2	2
P41	SPEED	2	3	3	4	5	3	4	5	5	3	4	5	4	4	4	2	3	3	5	3
	INCLINE	1	1	2	2	2	3	3	3	2	2	1	2	2	1	1	3	3	2	2	2
P42	SPEED	2	4	4	5	6	4	6	6	6	4	5	6	4	4	4	2	2	5	4	2
	INCLINE	1	2	2	2	2	3	3	2	2	2	2	2	3	3	3	4	4	3	2	2
P43	SPEED	2	4	4	6	6	4	7	7	7	4	7	7	4	4	4	2	4	5	3	2
	INCLINE	2	3	3	2	2	3	3	3	2	2	2	2	4	4	4	6	6	3	2	2
P44	SPEED	3	5	5	6	7	7	5	7	7	8	8	5	9	5	5	6	6	4	4	3
	INCLINE	2	3	3	2	2	3	3	3	2	2	2	2	4	4	4	6	6	3	2	2
P45	SPEED	2	4	4	5	6	7	7	5	6	7	8	8	5	4	3	3	6	5	4	2
	INCLINE	3	3	3	4	4	5	5	5	4	4	4	4	5	5	3	3	3	2	2	2
P46	SPEED	2	4	4	4	5	6	8	8	6	7	8	8	6	4	4	2	5	4	3	2

	INCLINE	3	5	5	5	4	4	4	3	3	3	3	4	4	4	3	3	3	4	3	2
P47	SPEED	2	3	3	3	4	5	3	4	5	3	4	5	3	3	3	6	6	5	3	3
	INCLINE	4	4	4	4	3	3	6	6	6	7	7	8	8	9	9	6	6	5	3	3
P48	SPEED	2	3	3	6	7	7	4	6	7	4	6	7	4	4	4	2	3	4	4	2
	INCLINE	4	5	5	5	6	6	6	7	8	9	9	9	10	10	10	12	12	8	6	3
P49	SPEED	2	4	4	7	7	4	7	8	4	8	9	9	4	4	4	5	6	3	3	2
	INCLINE	5	5	5	6	6	6	4	4	6	6	5	5	8	8	9	9	9	7	4	2
P50	SPEED	2	4	5	6	7	5	4	6	8	8	6	6	5	4	4	2	4	4	3	3
	INCLINE	5	6	6	6	7	5	8	8	4	4	4	5	5	8	8	10	10	8	6	3
P51	SPEED	2	5	8	10	7	7	10	10	7	7	10	10	6	6	9	9	5	5	4	3
	INCLINE	4	5	3	2	6	6	2	2	2	2	2	4	5	6	3	2	5	5	2	0
P52	SPEED	3	4	9	9	5	9	5	8	5	9	7	5	5	7	9	9	5	7	6	3
	INCLINE	1	2	3	2	3	5	5	0	0	2	3	5	7	3	3	5	6	5	3	3
P53	SPEED	3	4	9	9	5	9	5	8	5	9	7	5	5	7	9	9	5	7	6	3
	INCLINE	1	2	3	2	3	5	5	0	0	2	3	5	7	3	3	5	6	5	3	3
P54	SPEED	2	2	4	5	6	5	4	3	2	1	2	3	4	5	6	5	4	3	2	1
	INCLINE	1	1	1	1	1	1	1	1	1	1	1	1	1	1	1	1	1	1	1	1
P55	SPEED	2	4	6	8	6	6	4	4	2	2	2	4	6	8	6	6	4	4	2	2
	INCLINE	1	1	1	1	1	1	1	1	1	1	1	1	1	1	1	1	1	1	1	1
P56	SPEED	2	4	6	8	10	8	6	4	2	2	2	4	6	8	6	6	4	4	2	2
	INCLINE	5	5	5	6	6	6	4	4	6	6	5	5	8	8	9	9	9	7	4	2
P57	SPEED	2	2	6	6	8	10	6	6	2	2	2	2	6	6	8	10	6	6	2	2
	INCLINE	4	5	5	5	6	6	6	7	8	9	9	9	10	10	10	12	12	8	6	3
P58	SPEED	2	3	4	5	2	3	4	5	3	2	2	3	4	5	2	3	4	5	3	2
	INCLINE	4	4	4	4	3	3	6	6	6	7	7	8	8	9	9	6	6	5	3	3
P59	SPEED	2	4	6	2	4	6	2	4	6	2	2	4	6	2	4	6	2	4	6	2
	INCLINE	3	5	5	5	4	4	4	3	3	3	3	4	4	4	3	3	3	4	3	2
P60	SPEED	1	3	4	5	6	5	4	3	2	1	1	3	4	5	6	5	4	3	2	1
	INCLINE	3	3	3	4	4	5	5	5	4	4	4	4	5	5	3	3	3	2	2	2
P61	SPEED	2	3	3	4	5	3	4	5	5	3	4	5	4	4	4	2	3	3	5	3
	INCLINE	1	1	2	2	2	3	3	3	2	2	1	2	2	1	1	3	3	2	2	2
P62	SPEED	2	4	4	5	6	4	6	6	6	4	5	6	4	4	4	2	2	5	4	2
	INCLINE	1	2	2	2	2	3	3	2	2	2	2	2	3	3	3	4	4	3	2	2
P63	SPEED	2	4	4	6	6	4	7	7	7	4	7	7	4	4	4	2	4	5	3	2
	INCLINE	2	3	3	2	2	3	3	3	2	2	2	2	4	4	4	6	6	3	2	2
P64	SPEED	3	5	5	6	7	7	5	7	7	8	8	5	9	5	5	6	6	4	4	3
	INCLINE	2	3	3	2	2	3	3	3	2	2	2	2	4	4	4	6	6	3	2	2
P65	SPEED	2	4	4	5	6	7	7	5	6	7	8	8	5	4	3	3	6	5	4	2
	INCLINE	3	3	3	4	4	5	5	5	4	4	4	4	5	5	3	3	3	2	2	2
P66	SPEED	2	4	4	4	5	6	8	8	6	7	8	8	6	4	4	2	5	4	3	2
	INCLINE	3	5	5	5	4	4	4	3	3	3	3	4	4	4	3	3	3	4	3	2
P67	SPEED	2	3	3	3	4	5	3	4	5	3	4	5	3	3	3	6	6	5	3	3
	INCLINE	4	4	4	4	3	3	6	6	6	7	7	8	8	9	9	6	6	5	3	3
P68	SPEED	2	3	3	6	7	7	4	6	7	4	6	7	4	4	4	2	3	4	4	2
	INCLINE	4	5	5	5	6	6	6	7	8	9	9	9	10	10	10	12	12	8	6	3
P69	SPEED	2	4	4	7	7	4	7	8	4	8	9	9	4	4	4	5	6	3	3	2
	INCLINE	5	5	5	6	6	6	4	4	6	6	5	5	8	8	9	9	9	7	4	2
P70	SPEED	2	4	5	6	7	5	4	6	8	8	6	6	5	4	4	2	4	4	3	3
	INCLINE	5	6	6	6	7	5	8	8	4	4	4	5	5	8	8	10	10	8	6	3
P71	SPEED	2	5	8	10	7	7	10	10	7	7	10	10	6	6	9	9	5	5	4	3
	INCLINE	4	5	3	2	6	6	2	2	2	2	2	4	5	6	3	2	5	5	2	0
P72	SPEED	3	4	9	9	5	9	5	8	5	9	7	5	5	7	9	9	5	7	6	3
	INCLINE	1	2	3	2	3	5	5	0	0	2	3	5	7	3	3	5	6	5	3	3
P73	SPEED	3	4	9	9	5	9	5	8	5	9	7	5	5	7	9	9	5	7	6	3
	INCLINE	1	2	3	2	3	5	5	0	0	2	3	5	7	3	3	5	6	5	3	3
P74	SPEED	2	2	4	5	6	5	4	3	2	1	2	3	4	5	6	5	4	3	2	1
	INCLINE	1	1	1	1	1	1	1	1	1	1	1	1	1	1	1	1	1	1	1	1

P75	SPEED	2	4	6	8	6	6	4	4	2	2	2	4	6	8	6	6	4	4	2	2
	INCLINE	1	1	1	1	1	1	1	1	1	1	1	1	1	1	1	1	1	1	1	1
P76	SPEED	2	4	6	8	10	8	6	4	2	2	2	4	6	8	6	6	4	4	2	2
	INCLINE	5	5	5	6	6	6	4	4	6	6	5	5	8	8	9	9	9	7	4	2
P77	SPEED	2	2	6	6	8	10	6	6	2	2	2	2	6	6	8	10	6	6	2	2
	INCLINE	4	5	5	5	6	6	6	7	8	9	9	9	10	10	10	12	12	8	6	3
P78	SPEED	2	3	4	5	2	3	4	5	3	2	2	3	4	5	2	3	4	5	3	2
	INCLINE	4	4	4	4	3	3	6	6	6	7	7	8	8	9	9	6	6	5	3	3
P79	SPEED	2	4	6	2	4	6	2	4	6	2	2	4	6	2	4	6	2	4	6	2
	INCLINE	3	5	5	5	4	4	4	3	3	3	3	4	4	4	3	3	3	4	3	2
P80	SPEED	1	3	4	5	6	5	4	3	2	1	1	3	4	5	6	5	4	3	2	1
	INCLINE	3	3	3	4	4	5	5	5	4	4	4	4	5	5	3	3	3	2	2	2
P81	SPEED	2	3	3	4	5	3	4	5	5	3	4	5	4	4	4	2	3	3	5	3
	INCLINE	1	1	2	2	2	3	3	3	2	2	1	2	2	1	1	3	3	2	2	2
P82	SPEED	2	4	4	5	6	4	6	6	6	4	5	6	4	4	4	2	2	5	4	2
	INCLINE	1	2	2	2	2	3	3	2	2	2	2	2	3	3	3	4	4	3	2	2
P83	SPEED	2	4	4	6	6	4	7	7	7	4	7	7	4	4	4	2	4	5	3	2
	INCLINE	2	3	3	2	2	3	3	3	2	2	2	2	4	4	4	6	6	3	2	2
P84	SPEED	3	5	5	6	7	7	5	7	7	8	8	5	9	5	5	6	6	4	4	3
	INCLINE	2	3	3	2	2	3	3	3	2	2	2	2	4	4	4	6	6	3	2	2
P85	SPEED	2	4	4	5	6	7	7	5	6	7	8	8	5	4	3	3	6	5	4	2
	INCLINE	3	3	3	4	4	5	5	5	4	4	4	4	5	5	3	3	3	2	2	2
P86	SPEED	2	4	4	4	5	6	8	8	6	7	8	8	6	4	4	2	5	4	3	2
	INCLINE	3	5	5	5	4	4	4	3	3	3	3	4	4	4	3	3	3	4	3	2
P87	SPEED	2	3	3	3	4	5	3	4	5	3	4	5	3	3	3	6	6	5	3	3
	INCLINE	4	4	4	4	3	3	6	6	6	7	7	8	8	9	9	6	6	5	3	3
P88	SPEED	2	3	3	6	7	7	4	6	7	4	6	7	4	4	4	2	3	4	4	2
	INCLINE	4	5	5	5	6	6	6	7	8	9	9	9	10	10	10	12	12	8	6	3
P89	SPEED	2	4	4	7	7	4	7	8	4	8	9	9	4	4	4	5	6	3	3	2
	INCLINE	5	5	5	6	6	6	4	4	6	6	5	5	8	8	9	9	9	7	4	2
P90	SPEED	2	4	5	6	7	5	4	6	8	8	6	6	5	4	4	2	4	4	3	3
	INCLINE	5	6	6	6	7	5	8	8	4	4	4	5	5	8	8	10	10	8	6	3
P91	SPEED	2	5	8	10	7	7	10	10	7	7	10	10	6	6	9	9	5	5	4	3
	INCLINE	4	5	3	2	6	6	2	2	2	2	2	4	5	6	3	2	5	5	2	0
P92	SPEED	3	4	9	9	5	9	5	8	5	9	7	5	5	7	9	9	5	7	6	3
	INCLINE	1	2	3	2	3	5	5	0	0	2	3	5	7	3	3	5	6	5	3	3
P93	SPEED	3	4	9	9	5	9	5	8	5	9	7	5	5	7	9	9	5	7	6	3
	INCLINE	1	2	3	2	3	5	5	0	0	2	3	5	7	3	3	5	6	5	3	3
P94	SPEED	2	2	4	5	6	5	4	3	2	1	2	3	4	5	6	5	4	3	2	1
	INCLINE	1	1	1	1	1	1	1	1	1	1	1	1	1	1	1	1	1	1	1	1
P95	SPEED	2	4	6	8	6	6	4	4	2	2	2	4	6	8	6	6	4	4	2	2
	INCLINE	1	1	1	1	1	1	1	1	1	1	1	1	1	1	1	1	1	1	1	1
P96	SPEED	2	4	6	8	10	8	6	4	2	2	2	4	6	8	6	6	4	4	2	2
	INCLINE	5	5	5	6	6	6	4	4	6	6	5	5	8	8	9	9	9	7	4	2
P97	SPEED	2	2	6	6	8	10	6	6	2	2	2	2	6	6	8	10	6	6	2	2
	INCLINE	4	5	5	5	6	6	6	7	8	9	9	9	10	10	10	12	12	8	6	3
P98	SPEED	2	3	4	5	2	3	4	5	3	2	2	3	4	5	2	3	4	5	3	2
	INCLINE	4	4	4	4	3	3	6	6	6	7	7	8	8	9	9	6	6	5	3	3
P99	SPEED	2	4	6	2	4	6	2	4	6	2	2	4	6	2	4	6	2	4	6	2
	INCLINE	3	5	5	5	4	4	4	3	3	3	3	4	4	4	3	3	3	4	3	2

13. HRC PROGRAM LIST

HP1			HP2				HP3				
Age	Target zone (L-H)			Age	Target zone (L-H)			Age	Target zone (L-H)		
	Lowest	Default	Highest		Lowest	Default	Highest		Lowest	Default	Highest
15	160	165	170	15	170	175	180	15	170	175	180
16	159	164	169	16	169	174	179	16	170	175	180
17	158	163	168	17	168	173	178	17	170	175	180
18	157	162	167	18	167	172	177	18	169	174	179
19	156	161	166	19	166	171	176	19	169	174	179
20	155	160	165	20	165	170	175	20	168	173	178
21	154	159	164	21	164	169	174	21	168	173	178
22	153	158	163	22	163	168	173	22	168	173	178
23	152	157	162	23	162	167	172	23	167	172	177
24	151	156	161	24	161	166	171	24	167	172	177
25	150	155	160	25	160	165	170	25	166	171	176
26	149	154	159	26	159	164	169	26	166	171	176
27	148	153	158	27	158	163	168	27	166	171	176
28	147	152	157	28	157	162	167	28	165	170	175
29	146	151	156	29	156	161	166	29	165	170	175
30	145	150	155	30	155	160	165	30	165	170	175
31	144	149	154	31	154	159	164	31	164	169	174
32	143	148	153	32	153	158	163	32	164	169	174
33	142	147	152	33	152	157	162	33	163	168	173
34	141	146	151	34	151	156	161	34	163	168	173
35	140	145	150	35	150	155	160	35	163	168	173
36	139	144	149	36	149	154	159	36	162	167	172
37	138	143	148	37	148	153	158	37	162	167	172
38	137	142	147	38	147	152	157	38	161	166	171
39	136	141	146	39	146	151	156	39	160	165	170
40	135	140	145	40	145	150	155	40	160	165	170
41	134	139	144	41	144	149	154	41	159	164	169
42	133	138	143	42	143	148	153	42	159	164	169

43	132	137	142	43	142	147	152	43	158	163	168
44	131	136	141	44	141	146	151	44	158	163	168
45	130	135	140	45	140	145	150	45	158	163	168
46	129	134	139	46	139	144	149	46	157	162	167
47	128	133	138	47	138	143	148	47	156	161	166
48	127	132	137	48	137	142	147	48	155	160	165
49	126	131	136	49	136	141	146	49	154	159	164
50	125	130	135	50	135	140	145	50	153	158	163
51	124	129	134	51	134	139	144	51	152	157	162
52	123	128	133	52	133	138	143	52	151	156	161
53	122	127	132	53	132	137	142	53	150	155	160
54	121	126	131	54	131	136	141	54	149	154	159
55	120	125	130	55	130	135	140	55	148	153	158
56	119	124	129	56	129	134	139	56	147	152	157
57	118	123	128	57	128	133	138	57	146	151	156
58	117	122	127	58	127	132	137	58	145	150	155
59	116	121	126	59	126	131	136	59	144	149	154
60	115	120	125	60	125	130	135	60	143	148	153
61	114	119	124	61	124	129	134	61	142	147	152
62	113	118	123	62	123	128	133	62	141	146	151
63	112	117	122	63	122	127	132	63	140	145	150
64	111	116	121	64	121	126	131	64	139	144	149
65	110	115	120	65	120	125	130	65	138	143	148
66	109	114	119	66	119	124	129	66	137	142	147
67	108	113	118	67	118	123	128	67	136	141	146
68	107	112	117	68	117	122	127	68	135	140	145
69	106	111	116	69	116	121	126	69	134	139	144
70	105	110	115	70	115	120	125	70	133	138	143
71	104	109	114	71	114	119	124	71	132	137	142
72	103	108	113	72	113	118	123	72	131	136	141
73	102	107	112	73	112	117	122	73	130	135	140
74	101	106	111	74	111	116	121	74	129	134	139
75	100	105	110	75	110	115	120	75	128	133	138

76	99	104	109	76	109	114	119	76	127	132	137
77	98	103	108	77	108	113	118	77	126	131	136
78	97	102	107	78	107	112	117	78	125	130	135
79	96	101	106	79	106	111	116	79	124	129	134
80	95	100	105	80	105	110	115	80	123	128	133