



Chaser 2 Treadmill

USER MANUAL

Product may vary slightly from the item pictured due to model upgrades.



**Read all instructions carefully before using this product.
Retain this owner's manual for future reference.**

NOTE:

This manual may be subject to updates or changes. Up to date manuals are available through our website at www.lifespanfitness.com.au



TABLE OF CONTENTS

I. Important Safety Instructions	05
II. Important Electrical Information	07
III. Important Operating Instructions	08
IV. Assembly Instructions	09
V. Folding Instructions	13
VI. Operation Guide	14
VII. Exercise Guide	18
VIII. Maintenance Instructions	20
IX. Replacing Motor Brushes	24
X. Exploded Diagram	27
XI. Parts List	28
XII. Troubleshooting	30
XIII. Warranty	32

I. IMPORTANT SAFETY INSTRUCTIONS

WARNING: Read all instructions before using this treadmill.

It is important your treadmill receives regular maintenance to prolong its useful life. Failing to regularly maintain your treadmill may void your warranty.

DANGER

To reduce the risk of electric shock disconnect your treadmill from the electrical outlet prior to cleaning and/or service work.

DO NOT USE AN EXTENSION CORD:

DO NOT ATTEMPT TO DISABLE THE GROUNDED PLUG BY USING IMPROPER ADAPTERS OR IN ANY WAY MODIFY THE CORD SET.

- Install the treadmill on a flat level surface with access to a 220-240 volt (50/60Hz), grounded outlet.
- Do not operate treadmill on deeply padded, plush or shag carpet. Damage to both carpet and treadmill may result.
- Do not block the rear of the treadmill. Provide a minimum of 1 metre clearance between the rear of the treadmill and any fixed object.
- Place your unit on a solid, level surface when in use.
- When running, make sure the plastic clip is fastened on your clothing. It is for your safety, should you fall or move too far back on the treadmill.
- Keep hands away from all moving parts.
- Never operate the treadmill if it has a damaged power cord or plug. When damaged, these must be replaced by the manufacturer, its service agent or similarly qualified persons in order to avoid a hazard.
- Keep the cord away from heated surfaces.
- Do not operate where aerosol spray products are being used or where oxygen is being administered. Sparks from the motor may ignite a highly gaseous environment.
- Never drop or insert any object into any openings.

- The treadmill is intended for in-home use only and is not suitable for commercial environments.
- The pulse sensors are not medical devices. Various factors, including the user's movement, may affect the accuracy of heart rate readings. The pulse sensors are intended only as exercise aids in determining heart rate trends in general.
- Use the handrails provided; they are for your safety.
- Wear proper shoes. High heels, dress shoes, sandals or bare feet are not suitable for use on your treadmill. Quality athletic shoes are recommended to avoid leg fatigue.
- Before undertaking any type of exercise program, it is recommended that you consult a doctor.
- Injuries to health may result from incorrect or excessive training.
- This appliance is not intended for use by persons (including children) with reduced physical, sensory or mental capabilities, or lack of experience and knowledge, unless they have been given supervision or instruction concerning use of the appliance by a person responsible for their safety.
- **WARNING:** Heart rate monitoring systems may be inaccurate. If you feel faint stop exercising immediately.
- Children should not be allowed on or around the equipment, even when not in use.
- Children should be supervised to ensure that they do not play with this machine.
- Loose-fitting clothing or jewellery that could become an entanglement hazard should not be worn.
- Training shoes should be worn when using the equipment.
- Equipment must be used on a level and stable surface.
- All fixings should be checked before the equipment is used.
- All literature relating to the use of the equipment should be retained for future reference.
- Recommended operating temperature: 5-40°C.

II. IMPORTANT ELECTRICAL INFORMATION

WARNING!

- Route the power cord away from any moving part of the treadmill including the elevation mechanism and transport wheels.
- **NEVER** remove any cover without first disconnecting AC power.
- **NEVER** expose this treadmill to rain or moisture. This treadmill is not designed for use outdoors, near a pool, or in any other high humidity environment.
- This is a high-power item; please do not share the same outlet with other high-power machines such as, fridges, air conditioning etc. Please choose an outlet exclusively for the machine and make sure the fuse is 10A.

III. IMPORTANT OPERATING INSTRUCTIONS

- Understand that changes in speed and incline do not occur immediately. Set your desired speed on the computer console and release the adjustment key. The computer will obey the command gradually.
- Use caution while participating in other activities while walking on your treadmill, such as watching television, reading, etc. These distractions may cause you to lose balance or stray from walking in the centre of the belt; which may result in serious injury.
- This unit starts with at a very low speed. It is recommended to stand on the side rails and only step on the treadmill as it is moving on a slow speed. This will prolong the life of your motor and run the belt smoothly.
- This unit starts with at a very low speed. It is recommended to stand on the side rails and only step on the treadmill as it is moving on a slow speed. This will prolong the life of your motor and run the belt smoothly.
- Always hold on to handrail while making control changes.
- This machine has a safety key and a red safety button. Pressing the safety button or pulling the safety key will stop the walking belt immediately; the treadmill will shut off and reset
- Do not use excessive pressure on console control keys. They are precision set to function properly with little finger pressure.
- Replace any defective components immediately. The machine must be kept out of use until repaired.
- Belt wear-in period: all treadmills make a certain type of thumping noise due to the belt riding over the rollers, especially new treadmills. This noise will diminish over time, although may not completely go away. The belt will stretch over time, causing it to ride smoother over the rollers.
- Set up your machine for storage when the machine is not in use to ensure maximum longevity of electrical components via the following steps:
 1. Ensure incline (if applicable) is reset to zero.
 2. Turn off the machine via the red on/off switch located at the back of the motor. If your machine does not have a switch, turn off the machine at the wall power outlet.

IV. ASSEMBLY INSTRUCTIONS

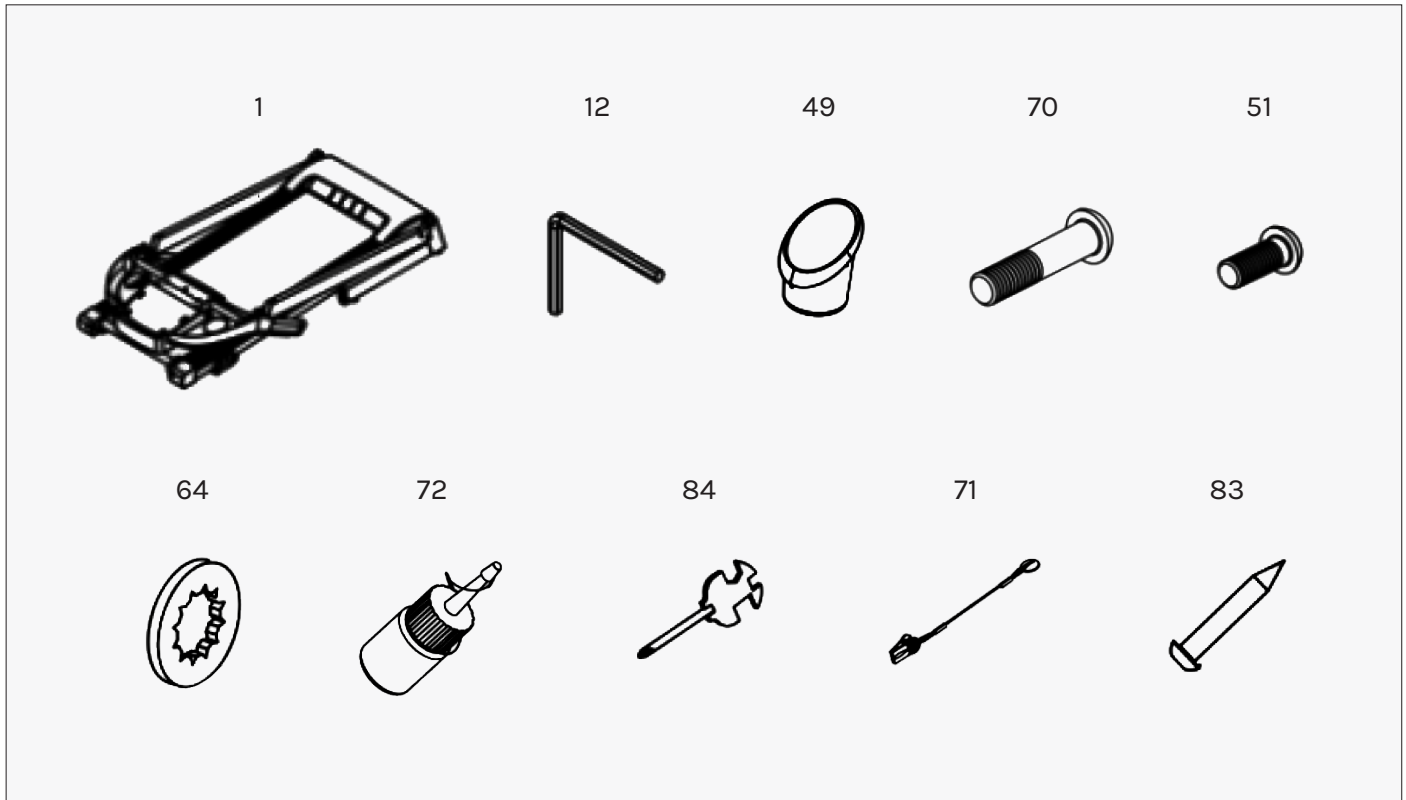

No.	Description	Specification	Qty	No.	Description	Specification	Qty
1	Main frame		1	64	Lock Washer	8	6
12	5# Allen Wrench		1	72	Oil Bottle		1
49	Water Holder		2	71	Safety Key		1
51	Bolt	M8*16	4	84	Wrench w/ Screw Driver	S=13, 14, 15	1
83	Bolt	4.2*12	2				

ASSEMBLY TOOLS:

#5 Allen Wrench 5mm 1pc

⚠ NOTICE:

Do not connect power until after assembly is completed.

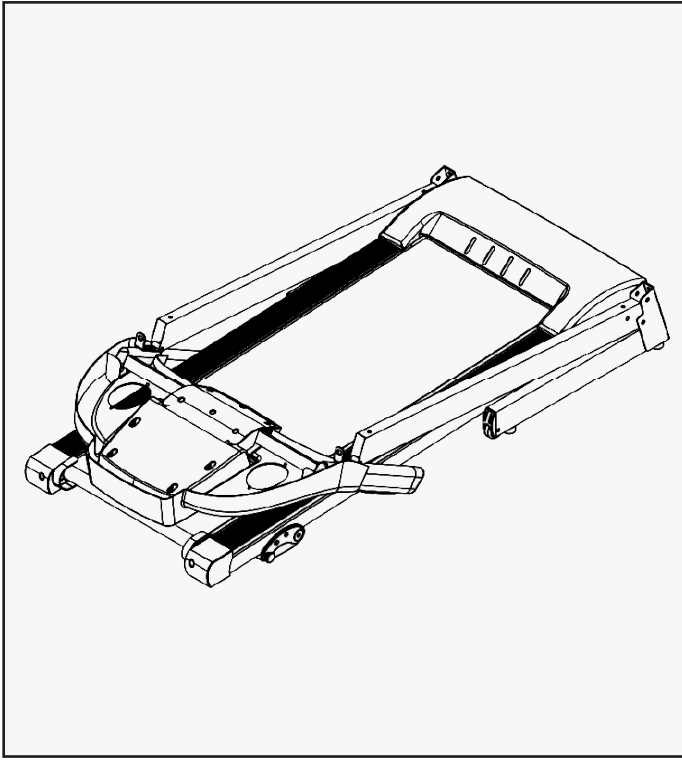

STEP 1

1. Open the carton.
2. Extract the parts listed above.
3. Place the Main Frame onto level ground.

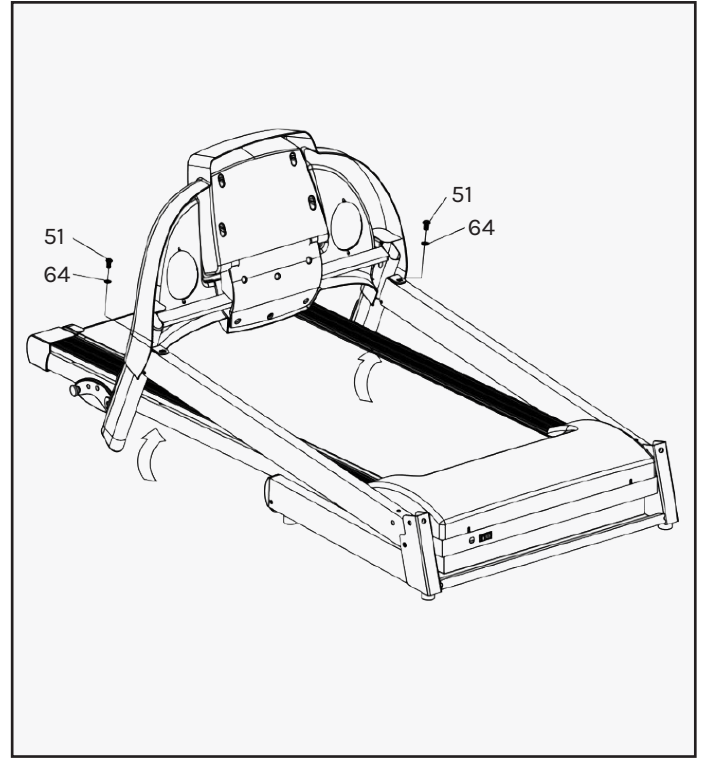

STEP 2

1. Position the display according to the diagram.
2. Using the 5# Allen wrench (12), secure the Display frame to Left Upright and Right Upright by using Bolt M8*16 (51) and Lock washer (64).

! NOTE:

Support the upright with your hands to prevent it falling down and causing injury.

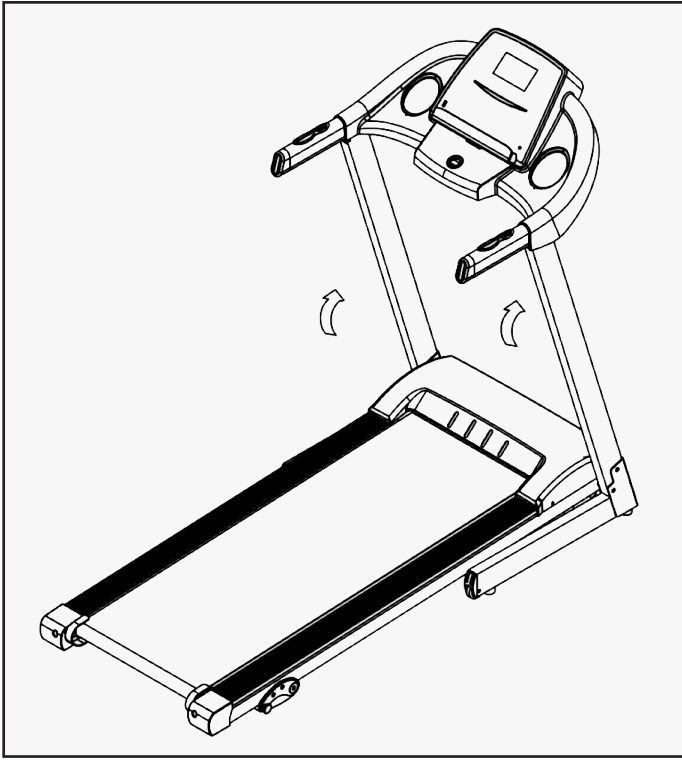

STEP 3

1. Carefully erect the display and the upright tubes.
2. Do not damage the display wire when doing so.

! **NOTE:**

Support the upright with your hand to avoid the display falling down and causing injury.

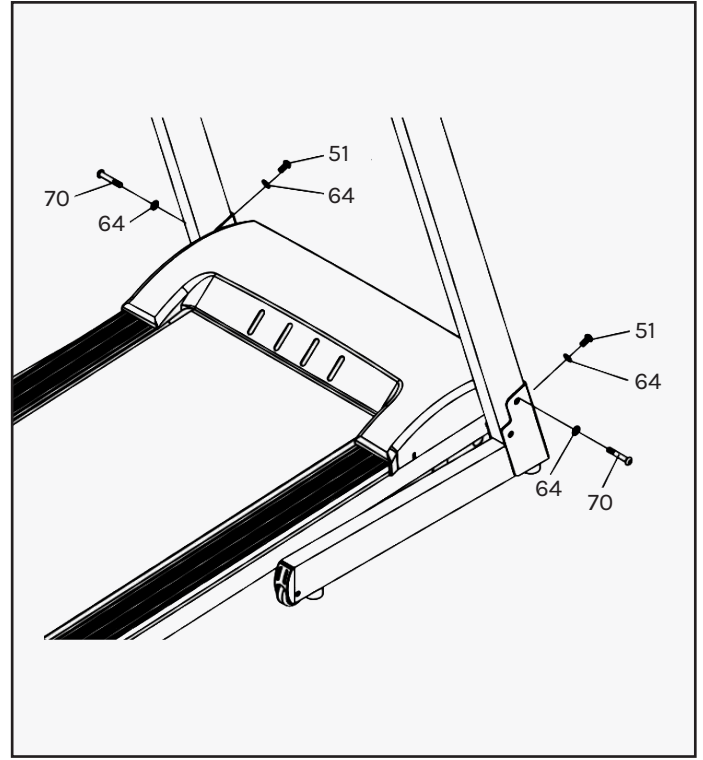

STEP 4

1. Using the 5# Allen wrench (12), screw in the Bolt M8*40 (70) and Lock washer (64).
2. Attach the Right Upright Tube to the Main Frame;
3. Use the 5# Allen wrench (12) to screw Bolt M8*16 (51) and Lock washer (64) to the base frame through base and right upright tube. **Reference the picture above.**

Repeat this method for the left side assembly.

! **NOTE:**

Support the upright with your hands to prevent it falling down and causing injury.

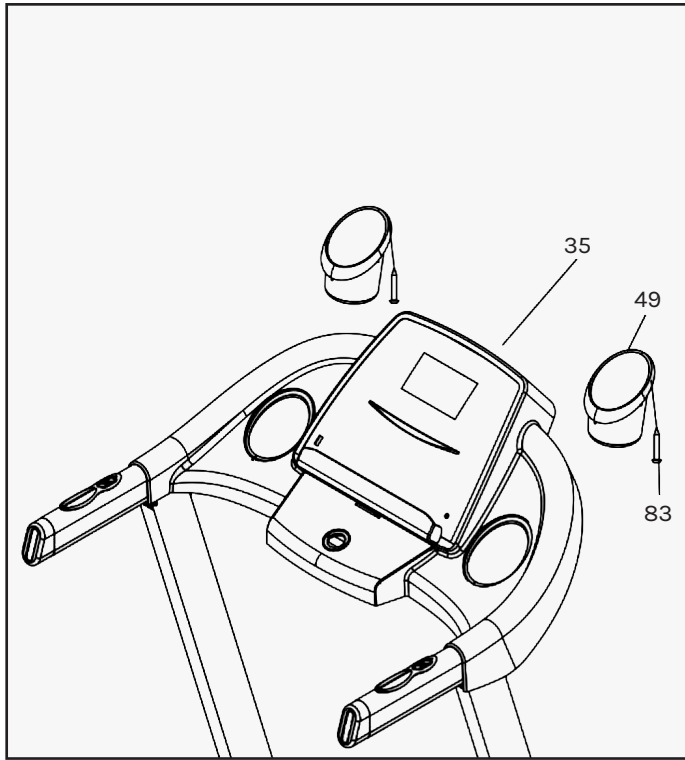

STEP 5

1. Place the Water holder (49) into the slots on the display.



STEP 6

1. Place the safety key (71) on the display.

V. FOLDING INSTRUCTIONS

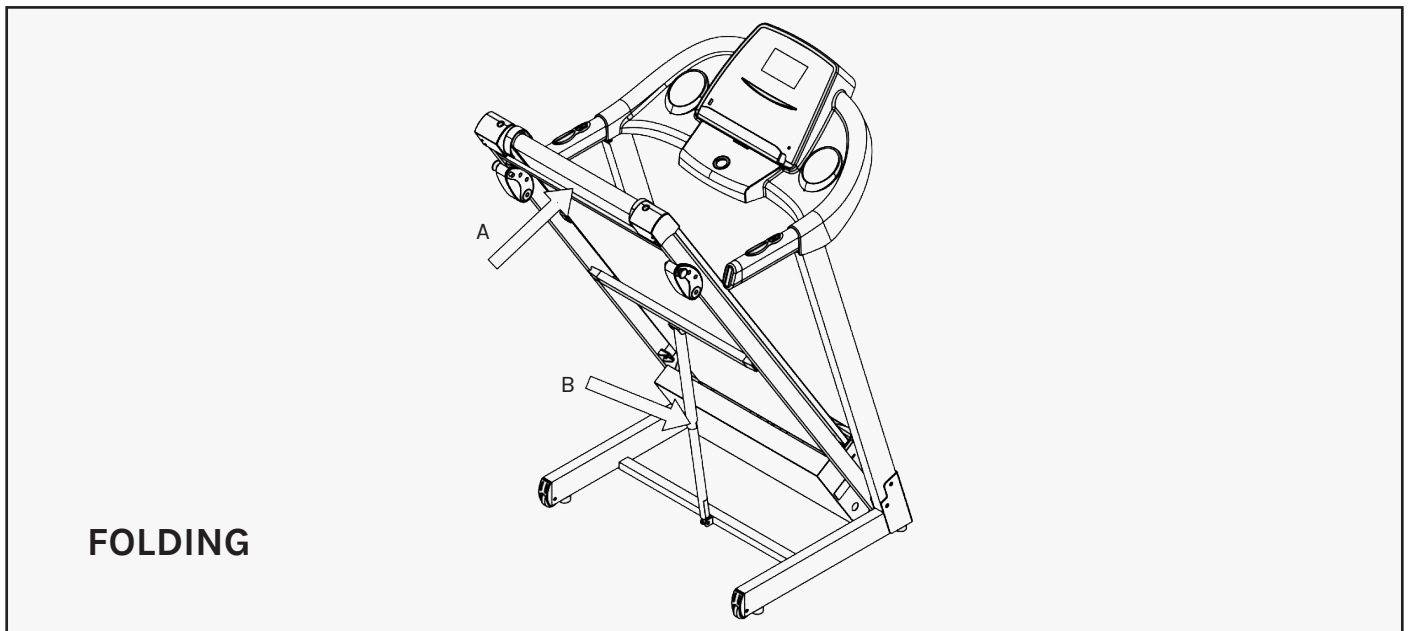

Place your hand on position (A), then pull up the base frame until you hear the click sound emitted when the air pressure bar (B) is locked into the round tube.

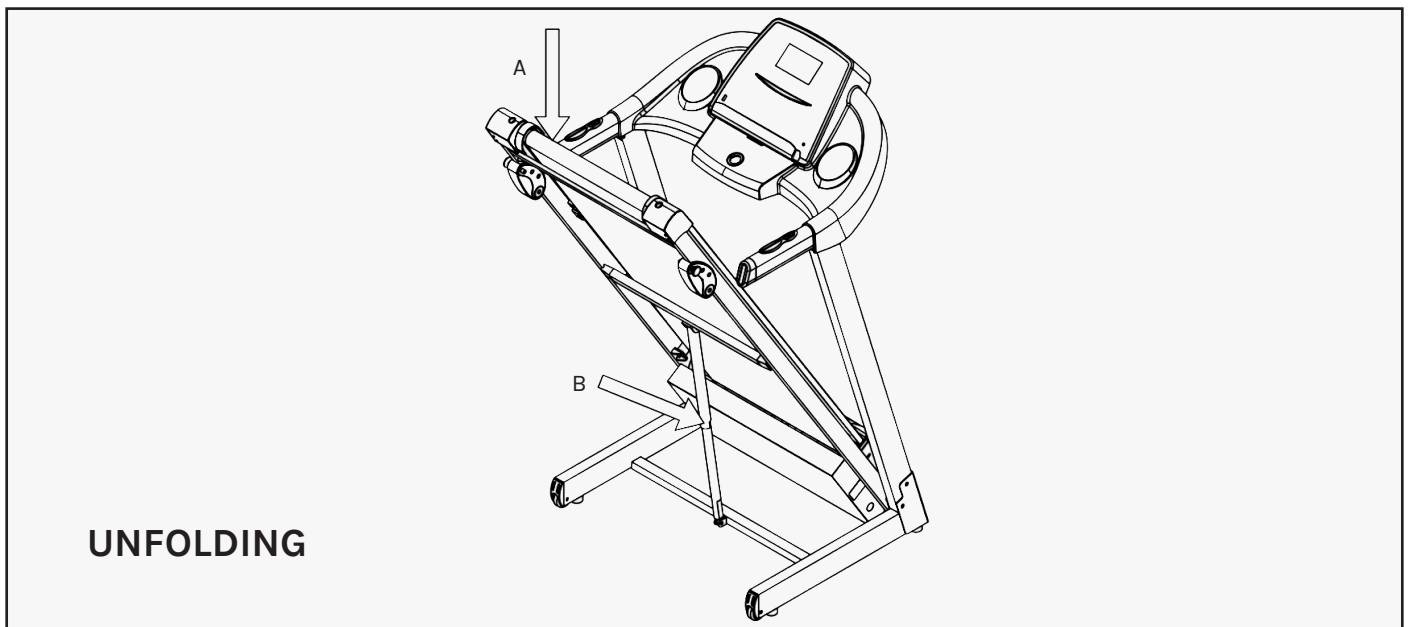

Whilst supporting position (A) with our hand, gently push position (B), the marked area on the air pressure bar, with your foot. The base frame will descend automatically. (Please keep people and pets away the machine during descent).

Video Tutorial Available at: <http://youtu.be/TcuPbJ7KuxQ>

Lifespan Fitness YouTube Channel: <http://www.youtube.com/user/treadmillsvideos>

VI. OPERATION GUIDE

OVERVIEW



LCD WINDOW DISPLAY

1. **SPEED WINDOW:** Shows speed.
2. **TIME WINDOW:** Displays exercise time.
3. **DIST WINDOW:** Shows the running distance.
4. **CALORIE WINDOW:** Shows the calories burnt. Calories burnt are an estimate only and are not to be used as medical data.
6. **PULSE WINDOW:** Shows heart rate. (Heart rate data is for reference ONLY.)

(Calorie and pulse data is an estimate intended for reference only. Not suitable for medical purposes.)

BUTTON FUNCTIONS:

1. **"PROGRAM"**: Choose the program, cycle from manual mode, P1 – P12 to FAT.
2. **"MODE"**: Mode selection button. Press this button to cycle the mode.

During standby mode, use MODE to choose between countdown mode, from TIME countdown, DISTANCE countdown and CALORIE countdown.
3. **"START"**: Begins workout. When the power is on and safety key correctly placed on the display, press this button to start the treadmill after a 3 second countdown.

Pressing the START button once will pause your workout. Pressing START twice will STOP your workout.
4. **"STOP"**: Press button to stop the motor running and to stop the machine.

Pressing the STOP once button during your workout will pause the workout and data on the LCD will remain. Press the START button to resume your workout. Instead of pressing START, you may clear the workout data by pressing the STOP button a second time.
5. **"SPEED+\SPEED-"**: Increase or decrease speed when exercising. Sets parameters when stopped.
6. **"SPEED: 2/4/6/8/10 & 3/5/7/9/11"**: Speed adjustment shortcut keys.

Left Handle Bar Buttons: Start/Stop

Right Handle Bar Buttons: Adjusts Speed

MAIN FUNCTIONS:

Quick Start-up (Manual):

Attach the safety key. After a 3 second countdown, the treadmill will start and run from the lowest speed, add and subtract to the speed using the SPEED +/- buttons.

Countdown Mode:

Press the MODE button to cycle options: timer countdown, distance countdown, calories countdown. The default value corresponds to the window and flashing display. At this point, the SPEED buttons serve as plus and minus functions to adjust to the desired value. Press the START, add and subtract speed by using SPEED buttons once again. When the countdown reaches 0, the machine will stop. You can also directly press the STOP button or disconnect the safety key to stop.

Manual Operation:

When in Standby mode, press the "START" button and the treadmill will run at speed 0.8KM/H. Other windows will begin to record your workout data. Use the "SPEED+", "SPEED-" buttons to change the speed.

Setting TIME countdown: When Standby mode, press the "MODE" button and the "Time" window will show "15:00" and light up. Use the "SPEED+", "SPEED-", buttons to set the desired workout time. The setting range is between: 5:00-99:00.

Setting DISTANCE countdown: When Standby mode, press "MODE" until the "DISTANCE" window displays "1.00" and lights up. Use the "SPEED+", "SPEED-", buttons to set total workout distance. The setting range

is between: 0.50-99.90.

Setting CALORIES countdown: When Standby mode, press "MODE" until the "CALORIES" window displays lights up. Use the "SPEED+", "SPEED-", buttons to set total workout distance. The setting range is between: 10.0-999.0.

Preset Program Operation:

Preset programs change speed and incline for you during your workout. Every program will have 20 intervals, in which speed can be adjusted between. See the next page for the program list.

Heart Rate:

When holding the hand pulse with two hands, the pulse window will show your heart rate after 5 seconds. To increase accuracy, please check heart rate after holding your hands on the sensors for more than 30 seconds when the machine stops. Please turn to the final page of document for more information about our pulse sensors.

The heart rate data is for reference purpose only and should not be used for medical purposes. Please turn to the end of this document for further detail.

Sleep Function:

The treadmill automatically enters sleep mode after 10 minutes of inactivity. Press any key on the display to wake the treadmill.

Safety Key Function:

Disconnecting the safety key will result in the treadmill beeping 3 times and stopping the current workout.

Data Display and Setting Range:

Setting	Range	Default Mode	Setting Range	Showing Range
TIME(MIN:SEC)	0:00	15:00	5:00-99:00	0:00-99:59
SPEED (KM/H)	-	-	-	0.8-14
DISTANCE (KM)	0	1.00	0.5-99.9	0.00-99.9
HEART BEAT (BEATS/MIN)	P	N/A	N/A	50-200
CALORIE (KILOCALORIES)	0	50.0	10.0-999	0-999

Body Fat Test Function:

1. Press the "PROGRAM" button under ready condition until the letters "FAT" show in the speed window. "FAT" is body fat test mode.
2. Press the "MODE" button to input data into parameters "SEX / AGE / HEIGHT / WEIGHT". The "TIME DIST" window will show "F1", "F2", "F3", "F4", which corresponds to "SEX / AGE / HEIGHT / WEIGHT" respectively. 01 is MALE, whilst 02 is FEMALE.
3. When setting each parameter, press SPEED ▲/▼ to adjust the data, and CAL/PULSE window will show the data. Press the "MODE" button to finish. The window will show "F5-" and "---" before entering into ready condition. Hold the hand pulse sensors with both hands and it will show your BMI data after 5 seconds.

4. Input parameter display and setting limits

Parameters	Arrangement	Description
SEX (F1)	01--02	01= MALE 02= FEMALE
AGE (F2)	10--99 YEARS	
HEIGHT (F3)	100--200 CM	
WEIGHT (F4)	20--150 KGS	
RESULT (F5)		

FA (BMI)	RESULT
≤19	UNDER WEIGHT
20--25	NORMAL WEIGHT
25--29	OVER WEIGHT
≥30	OBESE

PROGRAM CHART

PROGRAM	TIME	To set time/20 time = running time of each time period																			
		1	2	3	4	5	6	7	8	9	10	11	12	13	14	15	16	17	18	19	20
P01	SPEED	2	3	3	4	5	3	4	5	5	3	4	5	4	4	4	2	3	3	5	3
P02	SPEED	2	4	4	5	6	4	6	6	6	4	5	6	4	4	4	2	2	5	4	2
P03	SPEED	2	4	4	6	6	4	7	7	7	4	7	7	4	4	4	2	4	5	3	2
P04	SPEED	3	5	5	6	7	7	5	7	7	8	8	5	9	5	5	6	6	4	4	3
P05	SPEED	2	4	4	5	6	7	7	5	6	7	8	8	5	4	3	3	6	5	4	2
P06	SPEED	2	4	4	4	5	6	8	8	6	7	8	8	6	4	4	2	5	4	3	2
P07	SPEED	2	3	3	3	4	5	3	4	5	3	4	5	3	3	3	6	6	5	3	3
P08	SPEED	2	3	3	6	7	7	4	6	7	4	6	7	4	4	4	2	3	4	4	2
P09	SPEED	2	4	4	7	7	4	7	8	4	8	9	9	4	4	4	5	6	3	3	2
P10	SPEED	2	4	5	6	7	5	4	6	8	8	6	6	5	4	4	2	4	4	3	3
P11	SPEED	2	5	8	10	7	7	10	10	7	7	10	10	5	5	9	9	5	5	4	3
P12	SPEED	3	4	9	9	5	9	5	8	5	9	7	5	5	7	9	9	5	7	6	3

VII. EXERCISE GUIDE

! PLEASE NOTE:

Before beginning any exercise program, consult your physician. This is important especially if you are over the age of 45 or individuals with pre-existing health problems.

The pulse sensors are not medical devices. Various factors, including the user's movement, may affect the accuracy of heart rate readings. The pulse sensors are intended only as an exercise aid in determining heart rate trends in general.

Exercising is a great way to control your weight, improve your fitness and reduce the effect of aging and stress. The key to success is to make exercise a regular and enjoyable part of your everyday life.

The condition of your heart and lungs and how efficient they are in delivering oxygen via your blood to your muscles is an important factor to your fitness. Your muscles use this oxygen to provide enough energy for daily activity. This is called aerobic activity. When you are fit, your heart will not have to work so hard. It will pump a lot fewer times per minute, reducing the wear and tear of your heart.

So as you can see, the fitter you are, the healthier and greater you will feel.

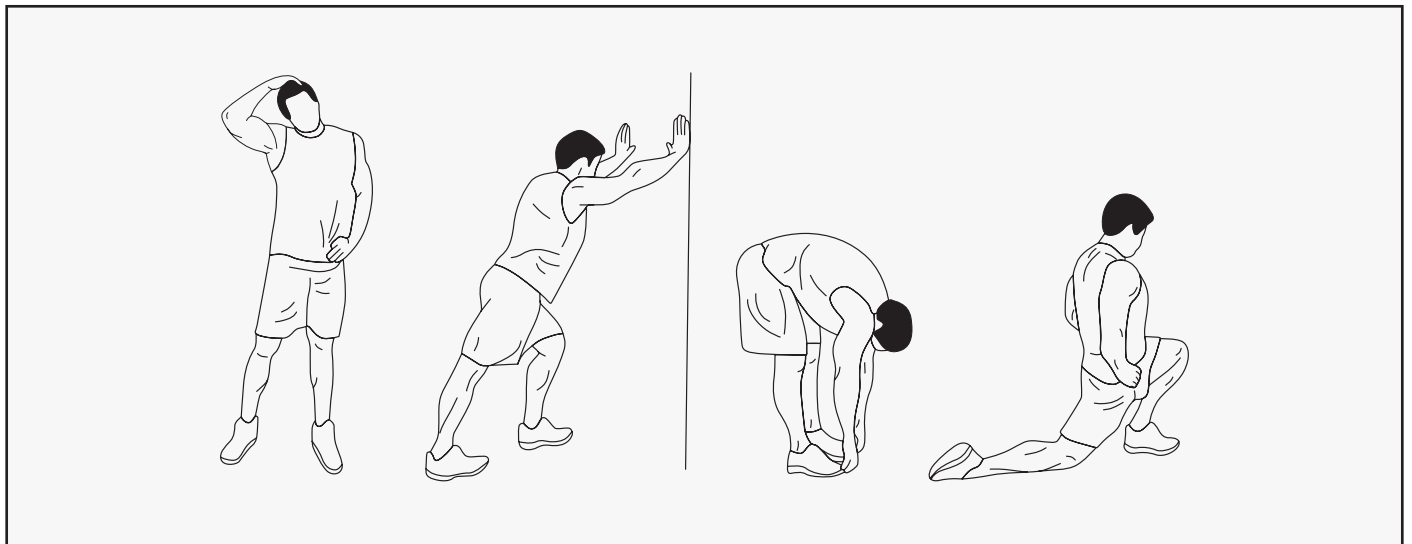

WARM UP

Start each workout with 5 to 10 minutes of stretching and some light exercises. A proper warm-up increases your body temperature, heart rate and circulation in preparation for exercise. Ease into your exercise.

After warming up, increase the intensity to your desired exercise program. Be sure to maintain your intensity for maximum performance. Breathe regularly and deeply as you exercise.

COOL DOWN

Finish each workout with a light jog or walk for at least 1 minute. Then complete 5 to 10 minutes of stretching to cool down. This will increase the flexibility of your muscles and will help prevent post-exercise problems.

WORKOUT GUIDELINES

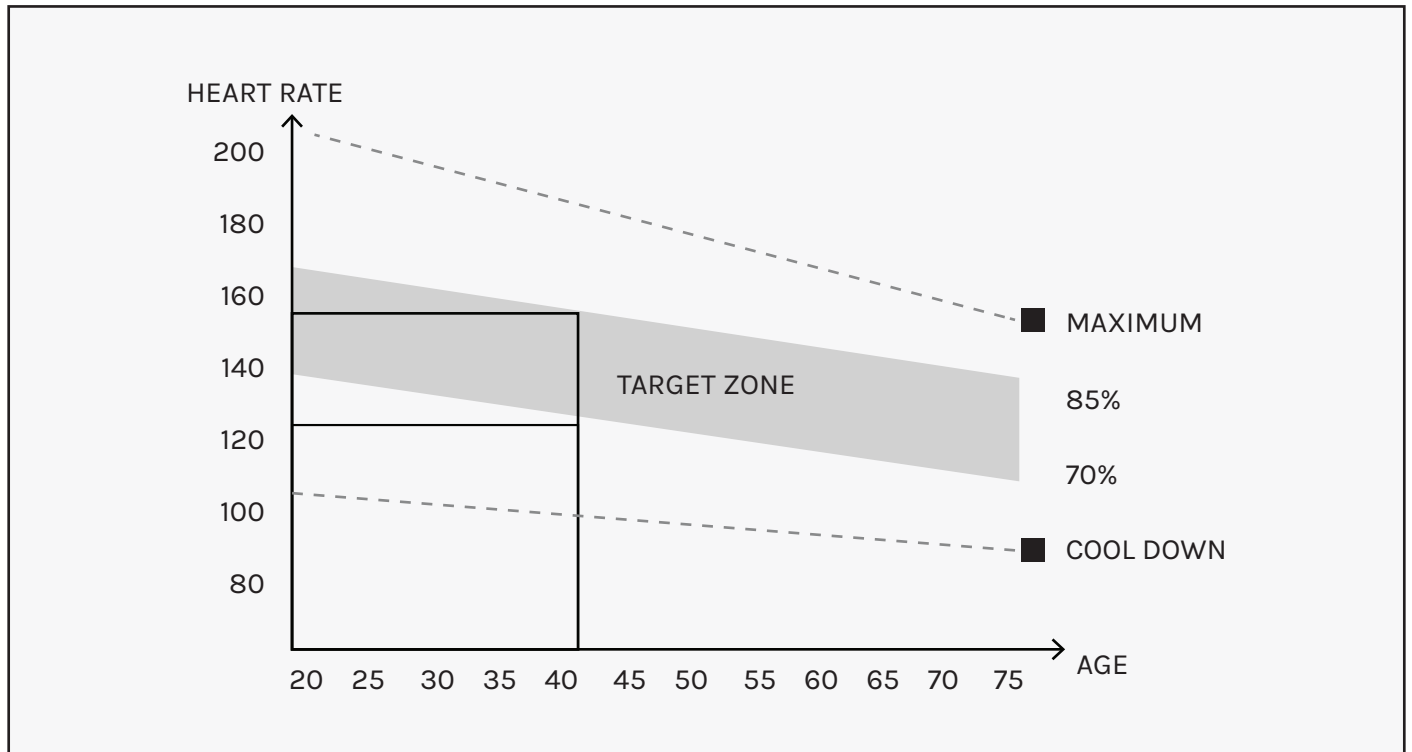

⚠ This is how your pulse should behave during general fitness exercise. Remember to warm up and cool down for a few minutes.

The most important factor here is the amount of effort you put in. The harder and longer you work, the more calories you will burn.

VIII. MAINTENANCE INSTRUCTIONS

Reasonable cleaning/lubricating should be made to extend the life time of this unit. Performance is maximized when the belt and mat are kept as clean as possible.

WARNING:

- The mat/deck friction may lay a major role in the function and life of your treadmill and that is why we recommend you constantly lubricate this friction point to prolong the useful life of your treadmill. Failing to do this may void your warranty.
 - Unplug power cord before maintenance.
 - Stop treadmill before folding.
-

1. GENERAL CLEANING

- Use a soft, damp cloth to wipe the edge of the belt and the area between the belt edge and frame. A mild soap and water solution along with a nylon scrub brush will clean the top of the textured belt. This task should be done once a month. Allow to dry before using.
- On a monthly basis, vacuum underneath your treadmill to prevent dust build up. Once a year, you should remove the black motor shield and vacuum out dirt that may accumulate.

2. GENERAL CARE

- Check parts for wear before use.
- Pay particular attention to the fixing knobs and make sure they are tight.
- Always replace the mat if worn and any other defective parts.
- If in doubt do not use the treadmill and contact us.

 **Take care to protect carpets and floor** in case of leakages. This product is a machine that contains moving parts which have been greased / lubricated and could leak.

3. BELT/DECK/ROLLER LUBRICATION

The mat/deck friction may play a major role in the function and life of your treadmill and that is why we recommend you constantly lubricate this friction point to prolong the useful life of your treadmill. You should apply lubrication after approximately the first 30 hours of operation.

We recommend lubrication of the deck according to the following timetable:

- Light use (less than 3 hours per week) every 6 months.
- Medium use (3-5 hours a week) every 3 months.
- Heavy use (more than 5 hours per week) every 6-8 weeks.

See below procedures for lubricating:

1. Use a soft, dry cloth to wipe the area between the belt and deck.
2. Spread lubricant onto the inside surface of belt and deck evenly (make sure the machine is turned off and power is disconnected).
3. Periodically lubricate the front and rear rollers to keep them at their peak performance. If the treadmill belt/deck/roller is kept reasonably clean it is possible to expect over 1200 hours before relubricating is necessary.

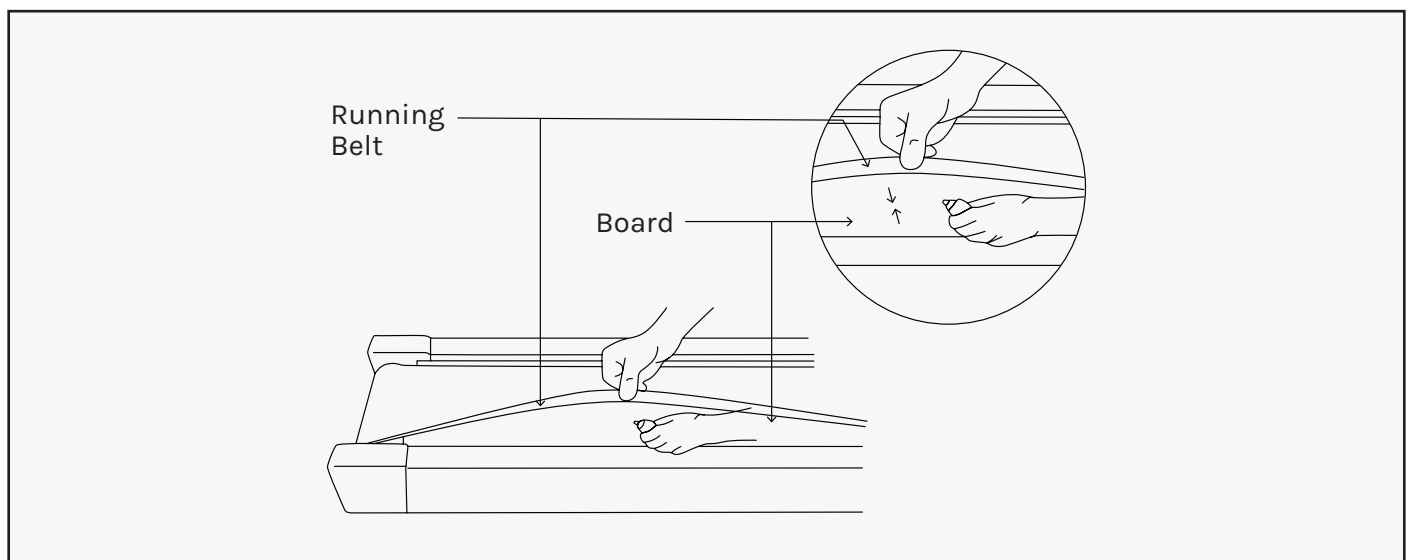

Video Tutorial Available at: <http://youtu.be/cP9NtFHfWlc>

Lifespan Fitness YouTube Channel: <http://www.youtube.com/user/treadmillsvideos>

4. HOW TO CHECK THE RUNNING MAT FOR PROPER LUBRICATION

1. Disconnect the main power supply.
2. Fold the treadmill up into the storage position.
3. Feel the underside surface of the running mat.

If the surface is slick when touched, then no further lubrication is needed.

If the surface is dry to the touch, apply a suitable silicone lubricant.

! We recommend that you use a silicone based spray to lubricate your treadmill.
This can be purchased directly from us or any hardware store.

Video Tutorial Available at: <http://youtu.be/cP9NtFHfWlc>

Lifespan Fitness YouTube Channel: <http://www.youtube.com/user/treadmillsvideos>

5. ADJUSTING THE RUNNING BELT

Place treadmill on a level surface. Run treadmill at approximately 4km/h, checking the running condition.

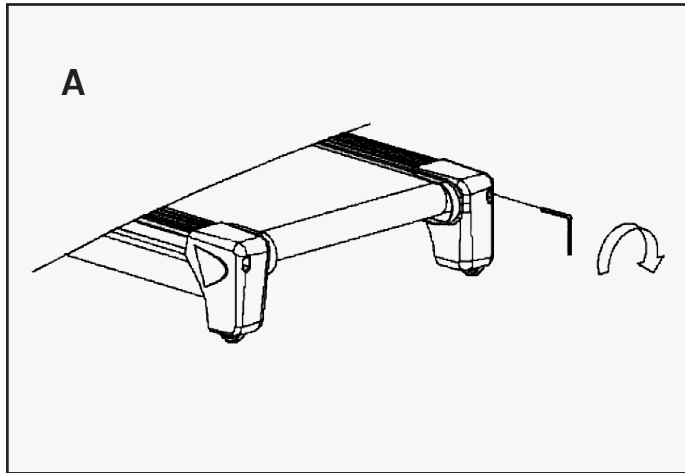

If the belt has drifted to the right: Whilst the treadmill is running at 4km/h, carefully turn the right adjusting bolt 1/4 turn clockwise. Then monitor treadmill until the belt centers. Repeat until the belt correctly centers.

See Picture A

If you have over adjusted the belt and it drifts to the right, carefully turn the right adjusting bolt anticlockwise until the belt centers.

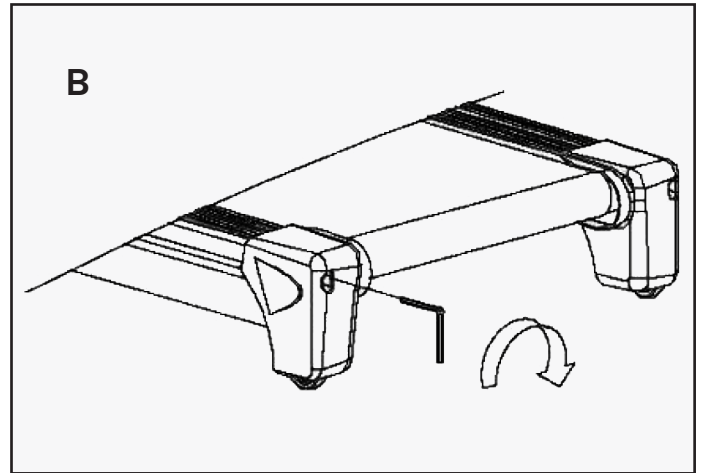

If the belt has drifted to the left: Whilst the treadmill is running at 4km/h, carefully turn the left adjusting bolt 1/4 turn clockwise. Then monitor treadmill until the belt centers. Repeat until the belt correctly centers.

See Picture B

If you have over adjusted it, carefully turn the left adjusting bolt anticlockwise and until the belt centers.

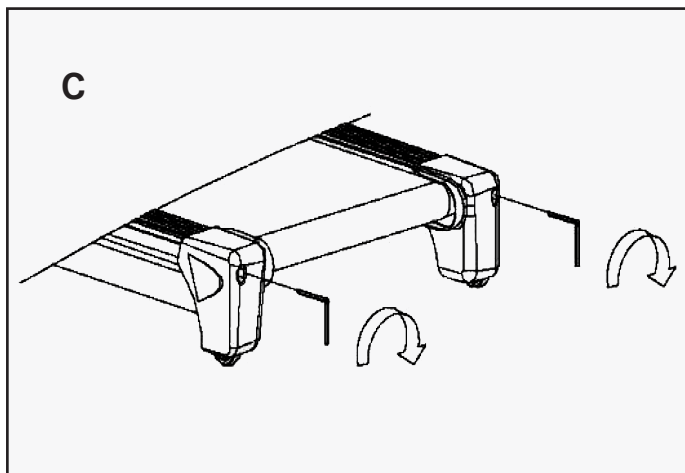

To adjust the tightness of the belt: Turn the treadmill off. Turn both the left and right adjusting bolts 1/4 turn clockwise. Repeat until the belt correctly tightens.

See Picture C

If the belt is over tightened, simply do the opposite to loosen.

! **NOTE:**

When properly tightened, you should be able to peel the very edge of the side of the belt up approximately 2 inches. However, this is a rough reference and not all treadmills are the same. Some treadmills that have longer belts may give different measurements for correct belt tightness.

Simply, if the belt begins to slip during use, this is an indication that the belt still needs tightening.

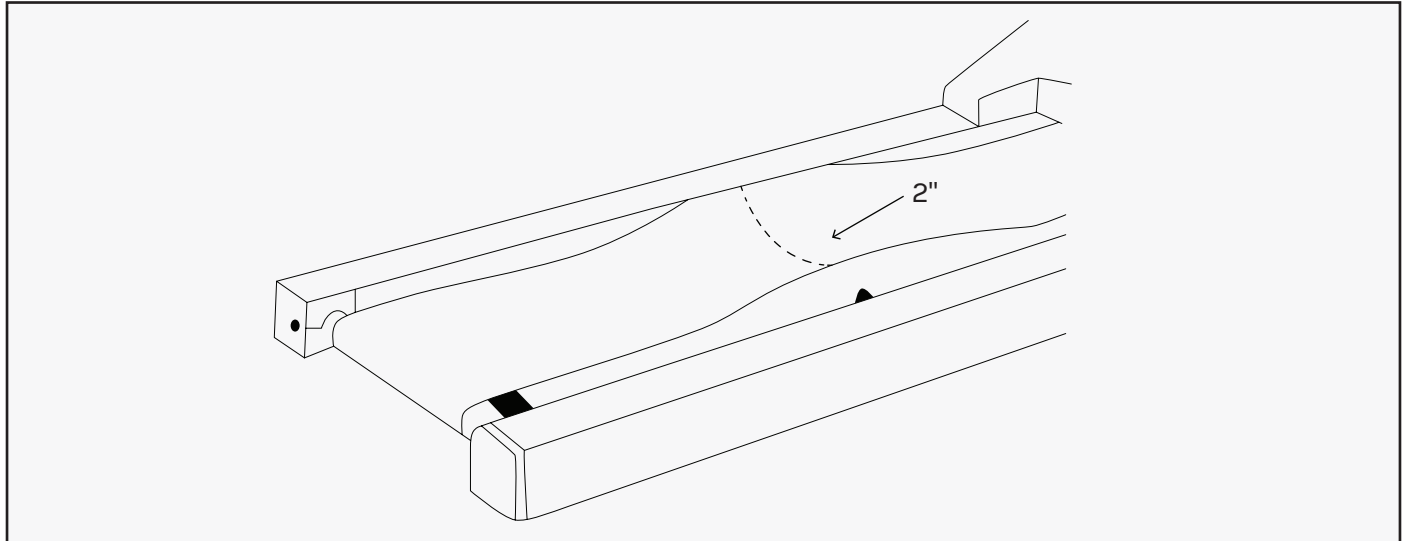

Video Tutorial Available at: <http://youtu.be/vllsamTSvva>

Lifespan Fitness YouTube Channel: <http://www.youtube.com/user/treadmillsvideos>

IX. REPLACING MOTOR BRUSHES

After extended use, the motor brushes in your treadmill motor will wear down, and this can lead to motor failure. It is important that you maintain your motor by replacing the brushes on either side of the motor when they are worn down. We recommend that you check your motor every 1000 hours of usage.

IMPORTANT:

Before beginning the replacement of your motor brush, ensure that the treadmill is off and unplugged from the electrical socket.

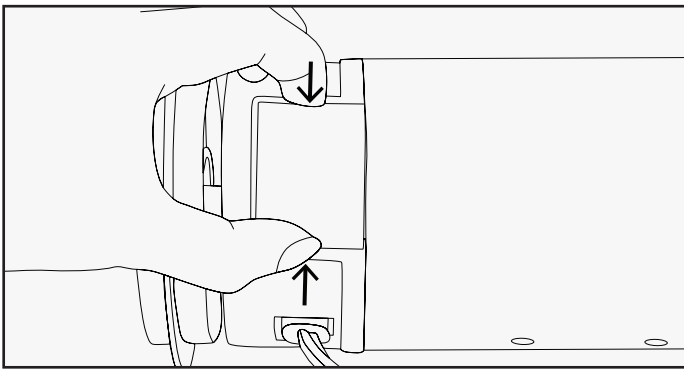

1. Remove the cover from the motor by squeezing it from the sides.

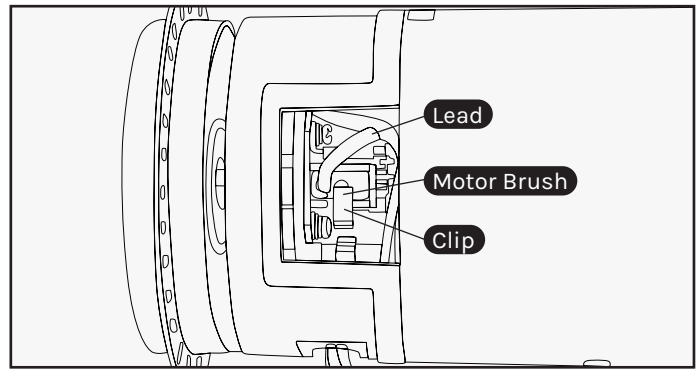

2. You will find the motor brush held in with a clip, with the lead plugged in.

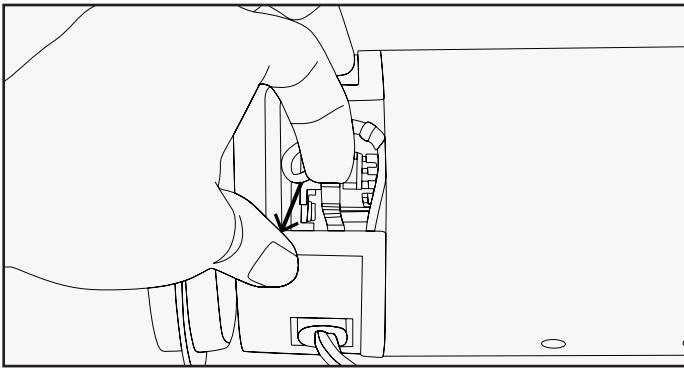

3. Pull the clip out from its position.

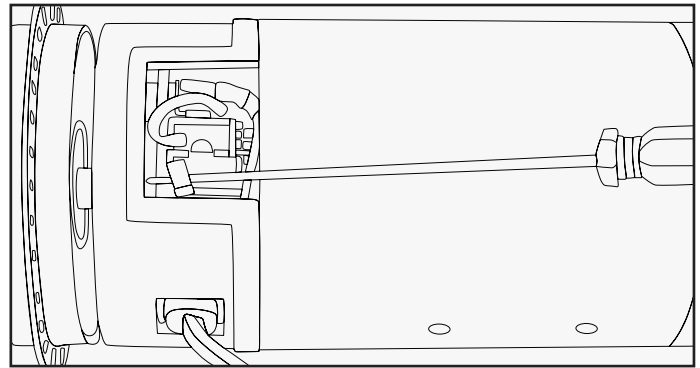

4a. Hold the clip out of the way with a screwdriver or similar object. Keep the screwdriver in this position until step 9.

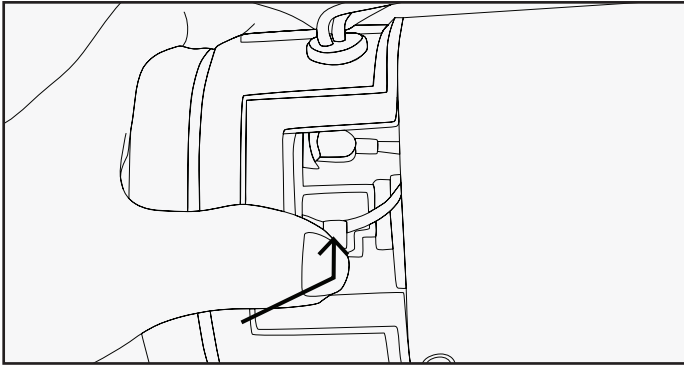

4b. Some treadmill motors may use a push clip instead. In this case, gently push the clip inwards and then up to release it from its latch.

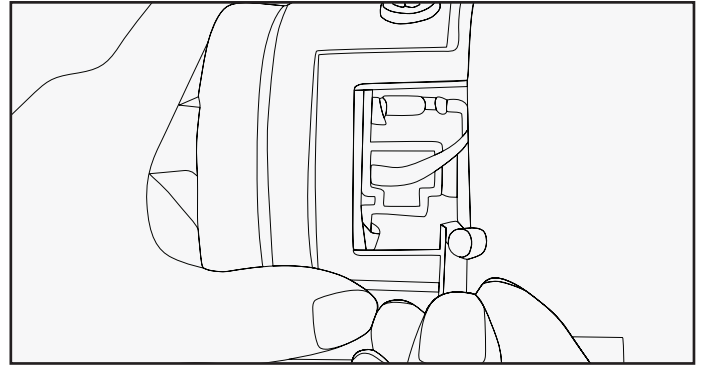

4c. Remove the clip, noting the direction in which it was originally placed, and put it safely aside.

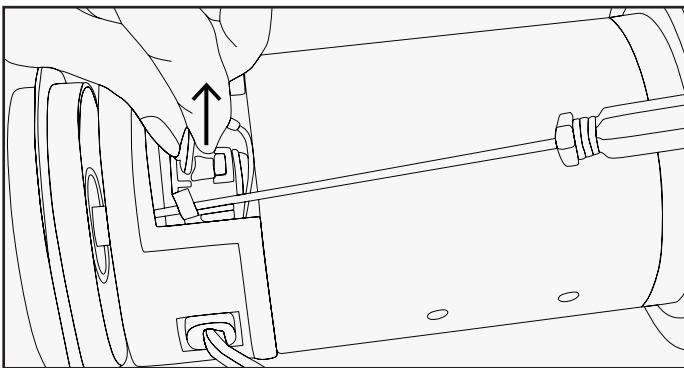

5. Slide the motor brush out from its slot. If the brush is shorter than 5mm on the longest side, you will need to replace both brushes.

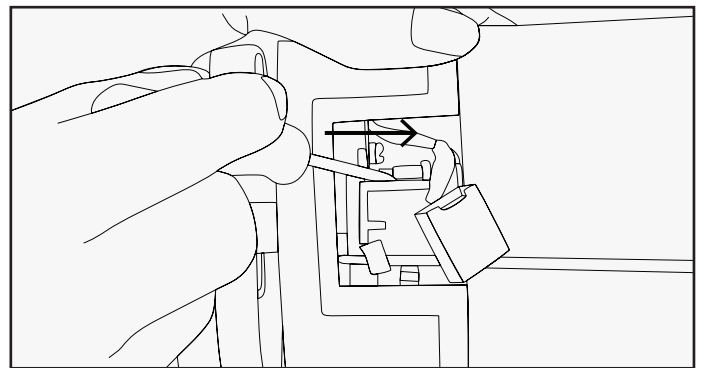

6. Slide the motor brush lead off the terminal using another small screwdriver or needle-nosed pliers.

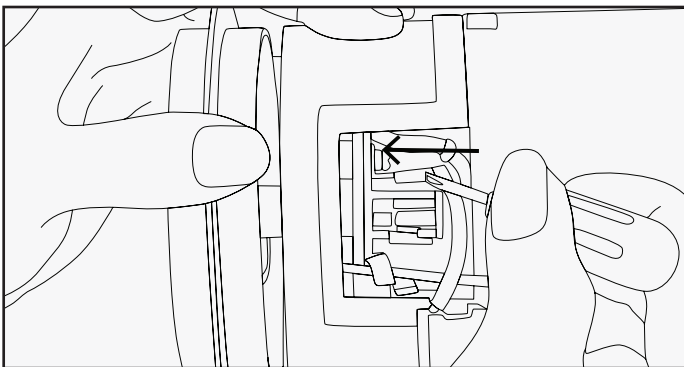

7. Plug the new motor brush lead into the terminal.

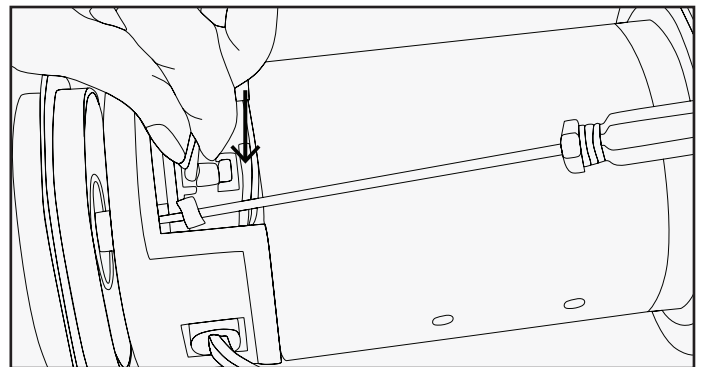

8. Slide the new motor brush into the slot.

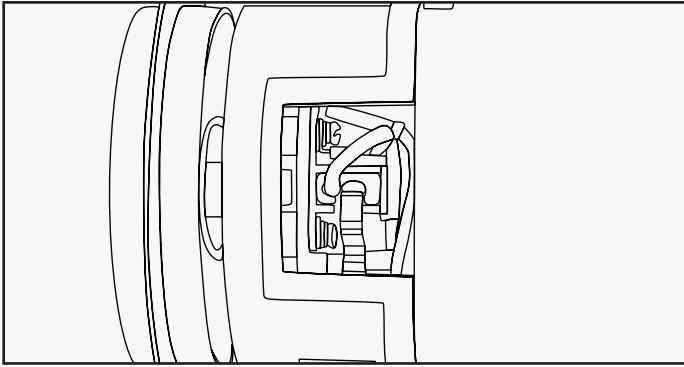

9a. Release the clip back into its position.

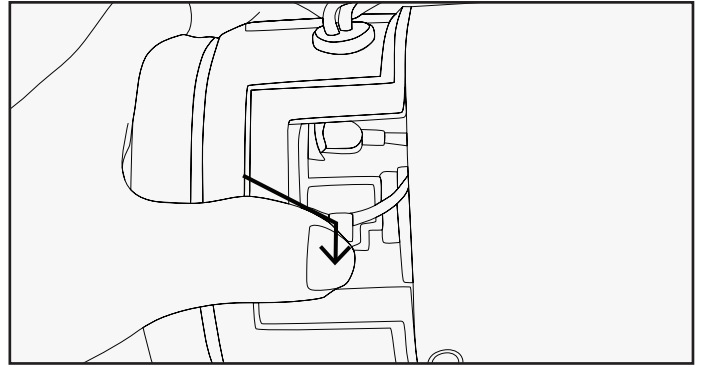

9b. If your motor uses a push clip, replace the push clip by pushing it inwards and then down so that it engages the catch.

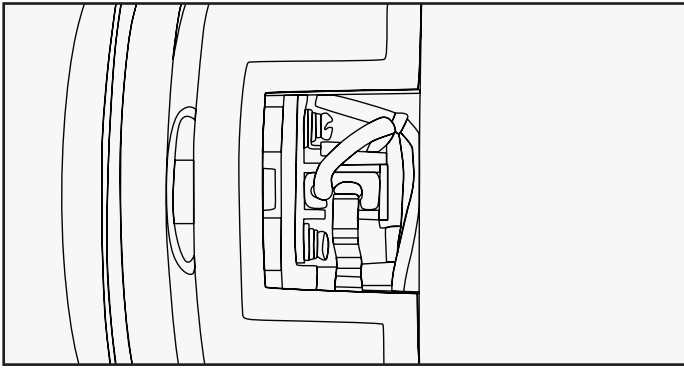

10. Check that the motor brush is held firmly in place by the clip, and that the lead is plugged securely onto the terminal.

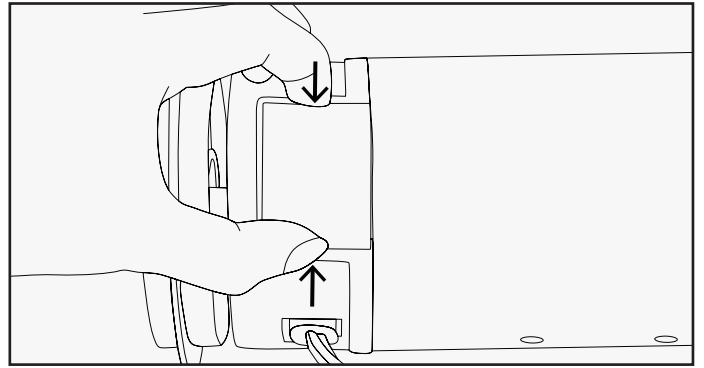

11. Replace the motor cover. Repeat steps 1-15 for the second brush located on the opposing side of the motor.

12. You have now successfully replaced the motor brushes. We also recommend that you remove any dirt and dust from your treadmill motor fan using a vacuum cleaner before replacing the cover.

X. EXPLODED DIAGRAM

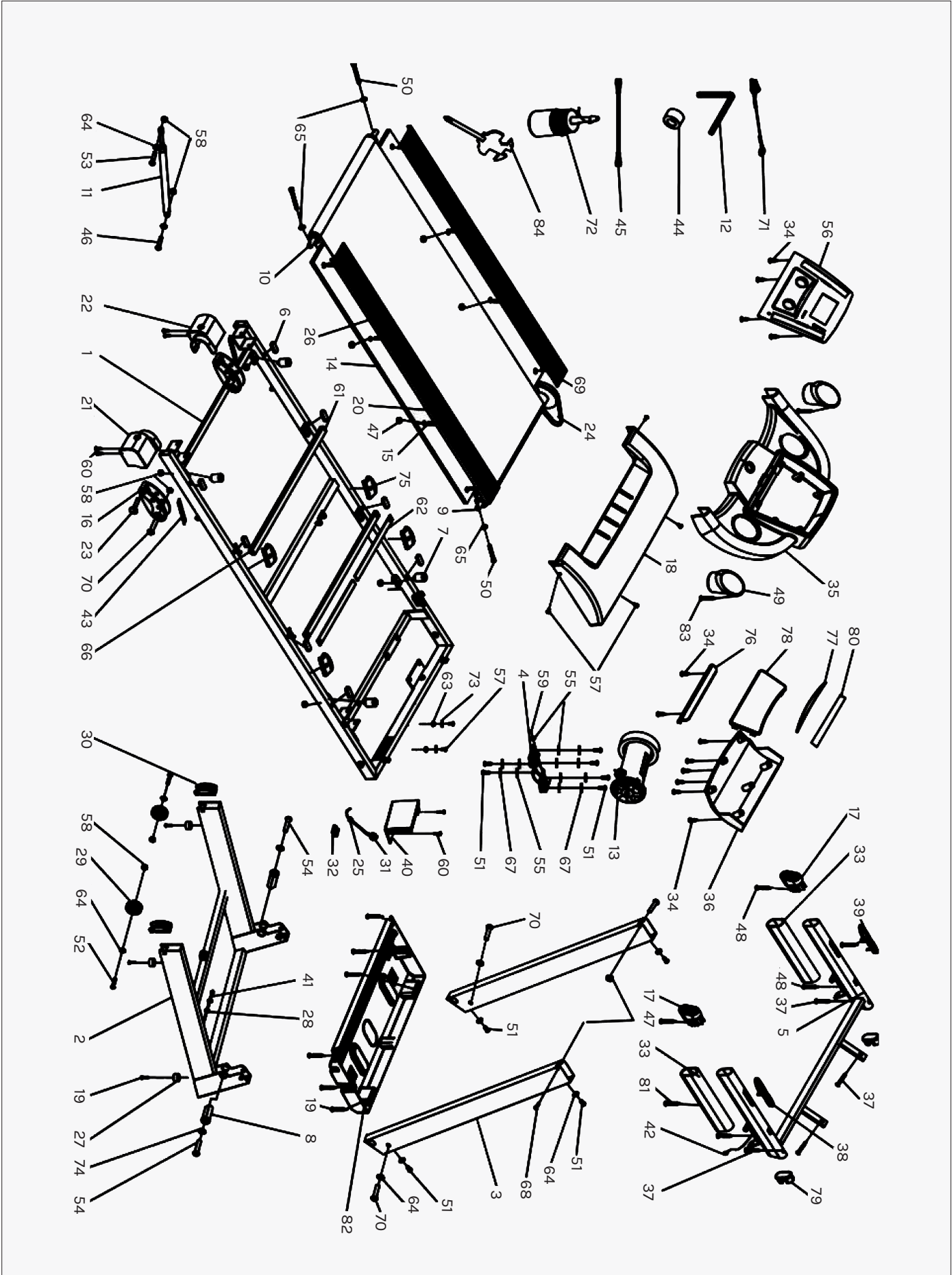

XI. PARTS LIST

No.	Description	Specs	Qty	No.	Description	Specs	Qty
1	Main Frame		1	34	Screw	ST4.2*20	12
2	Base Frame		1	35	Display Cover		1
3	Upright Frame		2	36	Display Seal Cover		1
4	Motor Bracket		1	37	Screw	ST4.2*20	6
5	Display Bracket		1	38	Hand Pulse with		1
6	Bolt	ST4.2*25	4	39	Hand Pulse with Start / Stop Key		1
7	Cushion		4	40	Control Board		1
8	Turning Tube		2	41	Display Bottom Wire		1
9	Front Roller		1	42	Display Up Wire		1
10	Rear Roller		1	43	Rubber Pad 2		2
11	Cylinder		1	44	Magnetic Ring		1
12	5#Allen Wrench	5mm	1	45	Brown Single Line		1
13	DC Motor		1	46	Bolt	M8*25	1
14	Running Board		1	47	Lock Nut	M6	6
15	Bolt	M6*40	4	48	Screw	ST4.2*28	2
16	Adjustable Pads		2	49	Water Holder		2
17	Inclined Tube Plug		2	50	Bolt	M6*65	3
18	Motor Up Cover		1	51	Bolt	M8*16	10
19	Screw	ST4.2*19	7	52	Bolt	M8*40	2
20	Side Rails		2	53	Bolt	M8*42	1
21	Right Back End Cover		1	54	Bolt	M10*55	2
22	Left Back End Cover		1	55	Flat Washer C	8	7
23	Lock Pin		2	56	Panel		1
24	Motor Belt		1	57	Bolt	M5*8	5
25	Power Wire Buckle		1	58	Lock Nut	M8	10
26	Running Belt		1	59	Bolt	M8*25	1
27	Foot Pad		4	60	Screw	ST4.2*19	6
28	Ring Wire Protector B		2	61	Running Board Strengthen Tube		2
29	Transport Wheel		2	62	Strengthen Tube Cushion	275*20*3	4
30	Transport Wheel Cover		2	63	Lock Washer	5	1
31	Standard Power Wire		1	64	Lock Washer	8	12
32	Switch		1	65	Lock Washer	6	3
33	Foam		2				

No.	Description	Specs	Qty
66	Nylon Isolation Pad	φ23* φ10.5*2	4
67	Lock Washer	8	6
68	Bolt	M6*37	2
69	Bolt	M8*25	4
70	Bolt	M8*40	4
71	Safety Key		1
72	Oil Bottle		1
73	Lock Washer	5	1
74	Lock Washer	10	2
75	Elastic Cushion		4

No.	Description	Specs	Qty
75	Elastic Cushion		4
76	iPad Rack		1
77	PU Pad		1
78	Speaker Box Grill		1
79	Elliptical Tube Plug		2
80	EVA		1
81	Screw	ST4.2*55	2
82	Motor Bottom Cover		1
83	Bolt	4.2*12	2
84	Wrench w/ Screw Driver	S=13, 14, 15	1

XII. TROUBLESHOOTING

CODE	POSSIBLE SOLUTIONS
E01	Reason: Signal failure within the connection between display and controller
	Solution: A. Check that the wires connecting the display and controller are not damaged and are connected well. B. Replace the IC of controller, the controller itself or display.
E02	Reason: Speed feedback is not detected by controller when motor is running.
	Solution: A. Check if the motor rotates when the machine starts before displaying the error. If so, conduct the following checks. 1. Check that the speed sensor is attached well. 2. Check that the speed sensor wires are not damaged. 3. Check that the interface between light sensor and 4 white pin on the controller is connected well. 4. Check if the peripheral area of the four white pin is damaged. 5. Consider replacing controller and IC. B. If the motor does not run when you start the machine the error shows, check if the motor is stuck. If the problem persists, consider replacing the motor.
E05	Reason: The voltage is over the protection value when the motor is running.
	Solution: A. Check if the motor is in good condition, and if there anything stuck in running belt or roller so as to unnaturally increase the resistance of for the motor. B. Replace the controller.
E06	Reason: DC motor or DC motor wire defective.
	Solution: A. Check if the motor wire is damaged, the safety pipe is damaged or fallen off, or the motor wire is not connected well; B. Check IGBT on bottom control board is burnt out. Test the above reasons and change the relevant part.
Unable to Control Speed	Solution: Refer to E03
No Power	Solution: A. Check the fuse. B. Check that the power plug terminal is in good contact with the controller.
Abnormal Motor Torque	Solution: A. Check whether the motor condition and motor belt tension. Replace motor if necessary. B. If motor is in good condition, replace control board or IC.
Motor Burnt Out	Solution: A. Check if the control is also burnt. B. Replace the motor. C. Replace the controller.

<p>Incline cannot be controlled</p>	<p>Solution:</p> <p>A. Check incline motor power wire and 3pin line connection with controller</p> <ol style="list-style-type: none"> 1. Remove the display wire installed on the controller (safety lock), turn on the power, press down on the small key on the right corner of controller 2 seconds. 2. The incline motor will initiate an automatic signal detection procedure. The motor will ascend to the highest level then descend to the lowest level. 3. When the motor reaches the lowest level, after 3 seconds, the procedure will be over. 4. After the procedure, connect the display wire (or the safety key). Operate the display function and test the incline function. <p>B. Change the controller.</p>
<p>Power Interruption</p>	<p>Solution:</p> <ol style="list-style-type: none"> A. Check if the power wire is connected well. B. Check wire - controller connection.
<p>No Display appearing on LCD</p>	<p>Solution:</p> <ol style="list-style-type: none"> A. Check if the voltage is correct. B. Check power to machine. Red on/off switch should light up. C. Change the controller. D. Change the display.
<p>LCD Screen Flashing</p>	<p>Solution:</p> <ol style="list-style-type: none"> A. Check if the voltage is correct. B. Change the controller. C. Change the display.
<p>LCD Display Faulty</p>	<p>Solution:</p> <ol style="list-style-type: none"> 1. Turn off power supply. 2. Repower the motor, observe if normal or not. 3. If not, remove display and fixed PCB. Check for damage. 4. If no damage clean the PCB gold finger position and retest.
<p>LCD Displaying but with Dysfunction</p>	<p>Solution:</p> <ol style="list-style-type: none"> A. Turn off power supply and repower the motor. B. Change the display.
<p>Backlight is not Bright</p>	<p>Solution:</p> <ol style="list-style-type: none"> A. Turn off the power supply and repower the motor. B. Start the display, check if all wires are connected well. Check for backlight damage. C. Change the display.
<p>A Button is not Functioning</p>	<p>Solution:</p> <ol style="list-style-type: none"> A. If only one key is not working, open the display and check the button for damage. B. Replace the display.
	<ol style="list-style-type: none"> A. If most keys do not work, restart the treadmill. B. Replace the display.
<p>Pulse Function is Unresponsive</p>	<p>Solution:</p> <ol style="list-style-type: none"> A. Wash your hands, test again. B. Check for damage to the pulse sensor cables as well as the connection terminal. C. Change PCB or display.

XIII. WARRANTY

AUSTRALIAN CONSUMER LAW

Many of our products come with a guarantee or warranty from the manufacturer. In addition, they come with guarantees that cannot be excluded under the Australian Consumer Law. You are entitled to a replacement or refund for a major failure and compensation for any other reasonably foreseeable loss or damage.

You are entitled to have the goods repaired or replaced if the goods fail to be of acceptable quality and the failure does not amount to a major failure. Full details of your consumer rights may be found at www.consumerlaw.gov.au.

Please visit our website to view our full warranty terms and conditions:
<http://www.lifespanfitness.com.au/warranty-repairs>

WARRANTY AND SUPPORT

Any claim against this warranty must be made through your original place of purchase. Proof of purchase is required before a warranty claim may be processed.

If you have purchased this product from the Official Lifespan Fitness website, please visit <https://lifespanfitness.com.au/warranty-form>

For support outside of warranty, if you wish to purchase replacement parts or request a repair or service, please visit <https://lifespanfitness.com.au/warranty-form> and fill in our Repair/Service Request Form or Parts Purchase Form.

Scan this QR code with your device to go to lifespanfitness.com.au/warranty-form





WWW.LIFESPANFITNESS.COM.AU