



# **LIFESPAN**

**FITNESS**

## **NOVA OWNER'S MANUAL**



**Product may vary slightly from the item pictured due to model upgrades**

**Read all instructions carefully before using this product. Retain this owner's manual for future reference.**

# TABLE OF CONTENTS

1.	IMPORTANT SAFETY INSTRUCTIONS_____	3
2.	IMPORTANT ELECTRICAL INFORMATION_____	4
3.	IMPORTANT OPERATING INSTRUCTIONS_____	5
4.	ASSEMBLY INSTRUCTIONS_____	6
5.	FOLDING INSTRUCTIONS_____	10
6.	OPERATION GUIDE_____	11
7.	EXERCISE GUIDE_____	15
8.	MAINTENANCE INSTRUCTIONS_____	17
9.	EXPLODED DIAGRAM_____	25
10.	PARTS LIST_____	26
11.	TROUBLE SHOOTING GUIDE_____	27
12.	WARRANTY_____	30

# 1. IMPORTANT SAFETY INSTRUCTIONS

**WARNING** - Read all instructions before using this treadmill.

It is important your treadmill receives regular maintenance to prolong its useful life. Failing to regularly maintain your treadmill may void your warranty.

**Danger** – To reduce the risk of electric shock disconnect your treadmill from the electrical outlet prior to cleaning and/or service work.

DO NOT USE AN EXTENSION CORD: DO NOT ATTEMPT TO DISABLE THE GROUNDED PLUG BY USING IMPROPER ADAPTERS OR IN ANY WAY MODIFY THE CORD SET.

- Install the treadmill on a flat level surface with access to a 220-240 volt (50/60Hz), grounded outlet.
- Do not operate treadmill on deeply padded, plush or shag carpet. Damage to both carpet and treadmill may result.
- Do not block the rear of the treadmill. Provide a minimum of 1 metre clearance between the rear of the treadmill and any fixed object.
- Place your unit on a solid, level surface when in use
- When running, make sure the plastic clip is fastened on your clothing. It is for your safety, should you fall or move too far back on the treadmill.
- Keep hands away from all moving parts.
- Never operate the treadmill if it has a damaged power cord or plug. When damaged, these must be replaced by the manufacturer, its service agent or similarly qualified persons in order to avoid a hazard.
- Keep the cord away from heated surfaces.
- Do not operate where aerosol spray products are being used or where oxygen is being administered. Sparks from the motor may ignite a highly gaseous environment.
- Never drop or insert any object into any openings.

- The treadmill is intended for in-home use only and not suitable for long term running.
- To disconnect, turn all controls to the off position, remove the safety key, and then remove the plug from the outlet.
- The pulse sensors are not medical devices. Various factors, including the user's movement, may affect the accuracy of heart rate readings. The pulse sensors are intended only as exercise aids in determining heart rate trends in general.
- Use the handrails provided; they are for your safety.
- Wear proper shoes. High heels, dress shoes, sandals or bare feet are not suitable for use on your treadmill. Quality athletic shoes are recommended to avoid leg fatigue.
- Before undertaking any type of exercise program, it is recommended that you consult a doctor.
- Injuries to health may result from incorrect or excessive training.
- This appliance is not intended for use by persons (including children) with reduced physical, sensory or mental capabilities, or lack of experience and knowledge, unless they have been given supervision or instruction concerning use of the appliance by a person responsible for their safety.
- WARNING heart rate monitoring systems may be inaccurate. If you feel faint stop exercising immediately.
- Children should not be allowed on or around the equipment, even when not in use.
- Children should be supervised to ensure that they do not play with this machine
- Loose-fitting clothing or jewellery that could become an entanglement hazard should not be worn.
- Training shoes should be worn when using the equipment.
- Equipment must be used on a level and stable surface.
- All fixings should be checked before the equipment is used.
- All literature relating to the use of the equipment should be retained for future reference.
- Allowed operating temperature: 5-40°C

Remove the safety key after use to prevent unauthorized treadmill operation.

## 2. IMPORTANT ELECTRICAL INFORMATION

### WARNING!

- Route the power cord away from any moving part of the treadmill including the elevation mechanism and transport wheels.
- NEVER remove any cover without first disconnecting AC power.
- NEVER expose this treadmill to rain or moisture. This treadmill is not designed for use outdoors, near a pool, or in any other high humidity environment.
- This is a high-power item; please do not share the same outlet with other high power machines such as, fridges, air conditioning etc. Please choose an outlet exclusively for the machine and make sure the fuse is 10A.

## 3. IMPORTANT OPERATING INSTRUCTIONS

- Understand that changes in speed and incline do not occur immediately. Set your desired speed on the computer console and release the adjustment key. The computer will obey the command gradually.
- Use caution while participating in other activities while walking on your treadmill, such as watching television, reading, etc. These distractions may cause you to lose balance or stray from walking in the centre of the belt; which may result in serious injury.
- In order to prevent losing balance and suffering unexpected injury, never mount or dismount the treadmill while the belt is moving. This unit starts with at a very low speed. Simply standing on the belt during slow acceleration is proper after you have learned to operate this machine.
- Always hold on to handrail while making control changes.
- A safety key is provided with this machine. Remove the safety key will stop the walking belt immediately; the treadmill will shut off automatically. Inserting the safety key will reset the display.
- Do not use excessive pressure on console control keys. They are precision set to function properly with little finger pressure.

- Replace any defective components immediately. The machine must be kept out of use until repaired.

## 4. ASSEMBLY INSTRUCTIONS

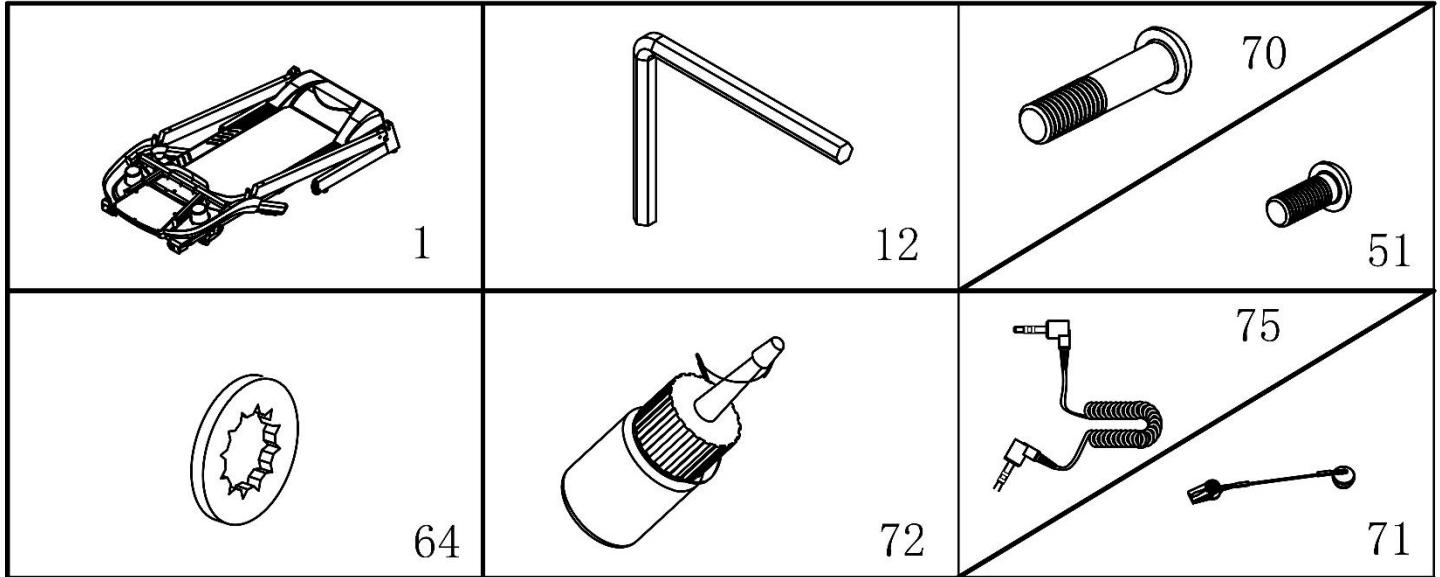

### PARTS LIST

NO.	Description	Specification	Nos.	NO.	Description	Specification	Nos.
1	Main Frame		1	64	Lock Washer	8	6
12	5#Allen Wrench	5mm	1	72	Oil bottle		1
70	Bolt	M8*45	2	71	Safety Key		1
51	Bolt	M8*16	4	75	Mp3		1

### ASSEMBLY TOOLS:

5# Allen Wrench 5mm: 1pcs

Wrench with screw driver S=13,14,15: 1pcs

**STEP 1:**

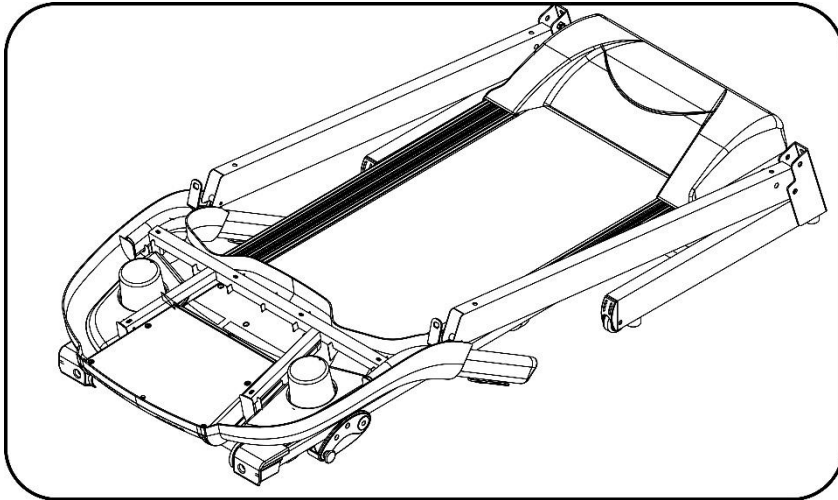

1. Open the carton. Place the Main Frame onto level ground.

**STEP 2:**

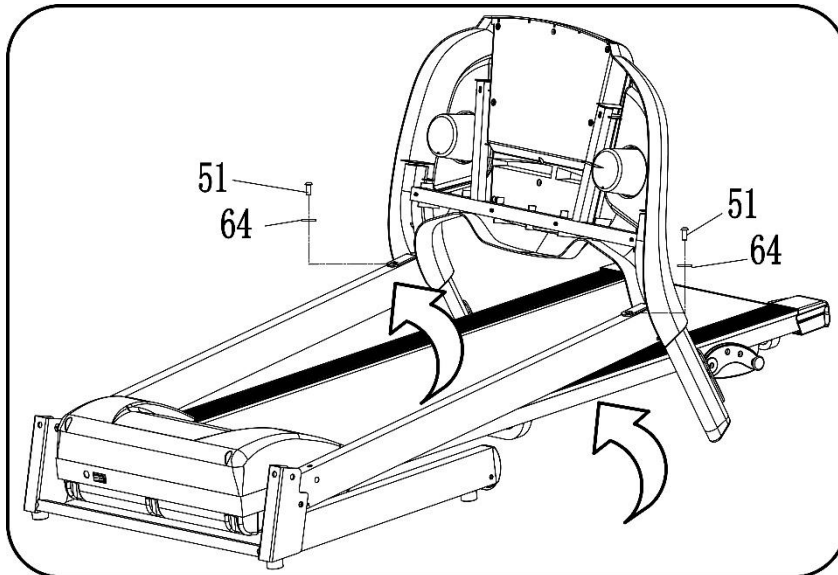

1. Hold the console frame.
2. Using the 5#Allen Wrench, attach the console frame onto the left and right upright tube with bolt (51) & lock washer (64)

**STEP 3:**

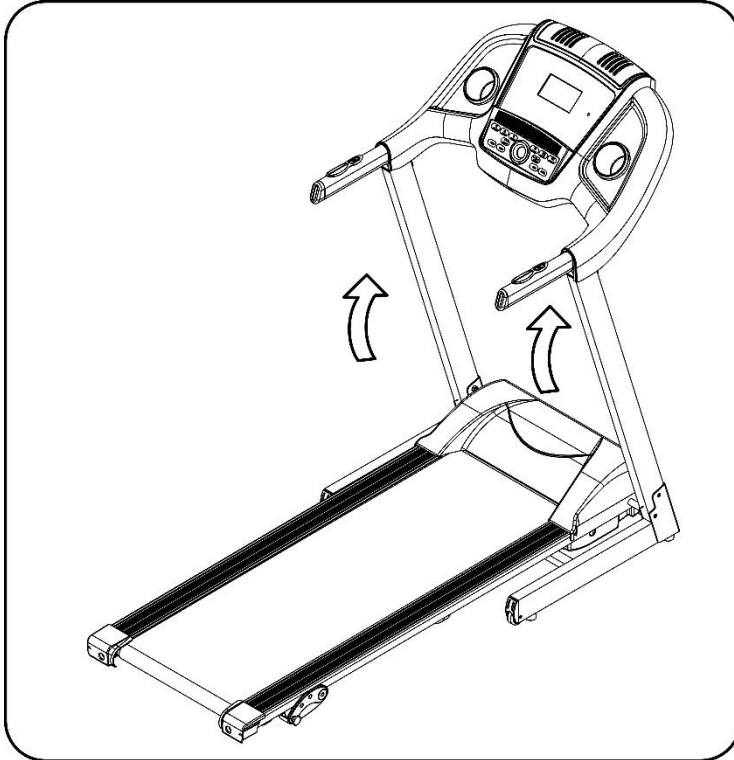

1. Erect the Upright

**STEP 4:**

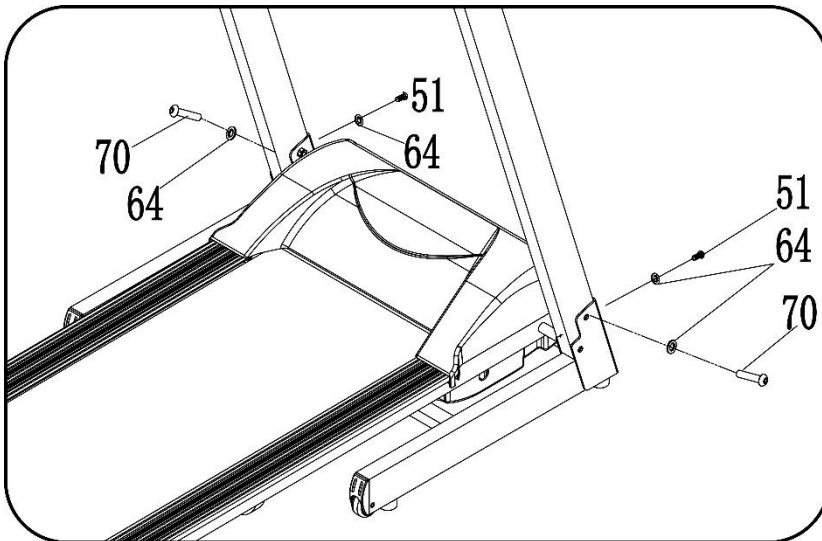

1. Using the 5# Allen wrench (12), insert the Bolt M8\*45 (70) through the Lock Washer (64). Use this to lock the left and right uprights to the main frame.
2. Use the 5# Allen wrench (12) to insert the M8\*16 Bolt (51) through the Lock Washer (64) and then into the assembly to further secure the upright/main frame assembly.

Reference the picture left.

Attention: Hold the upright tubes when attaching them to the main frame.



**STEP 5:**

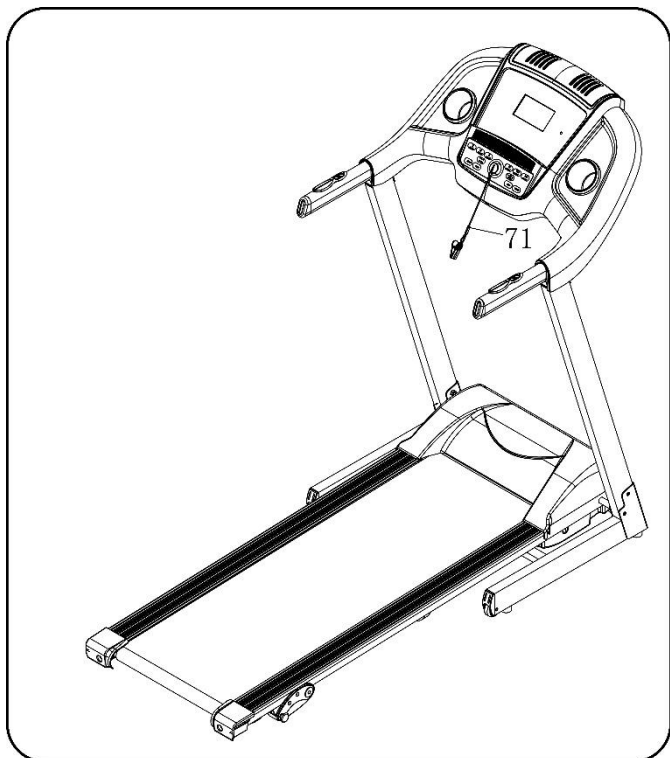

1. Attach the Safety Key (71) onto the console

## 5. FOLDING INSTRUCTIONS

### Folding:

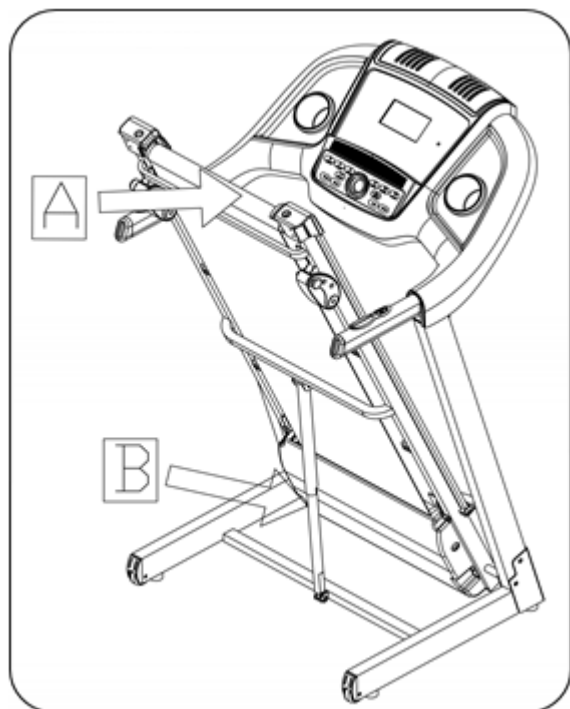

Place your hand on position (A), then pull up the base frame until you hear the click sound emitted when the air pressure bar (B) is locked into the round tube.

### Unfolding:

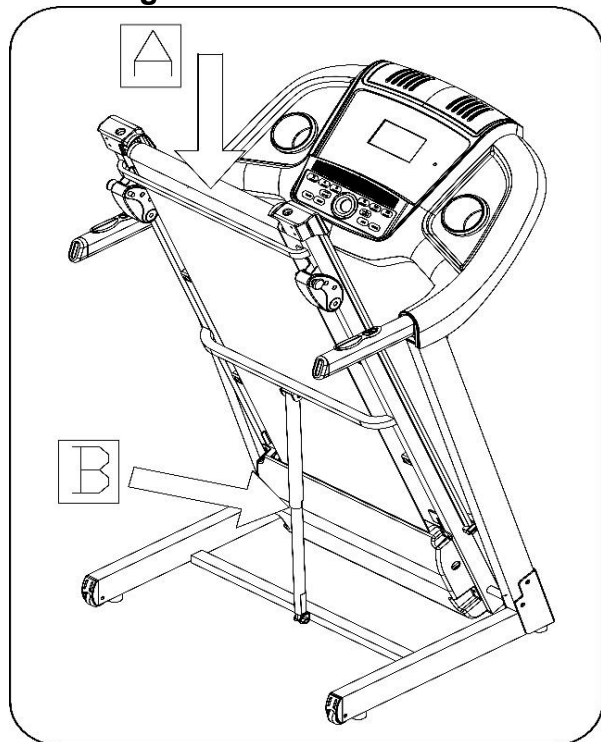

Whilst supporting position A with our hand, gently push the marked area on the air pressure bar with your foot.

The base frame will descend automatically. (Please keep people and any pets away the machine during descent)

Video Tutorial Available at:  
<http://youtu.be/cP9NtFHfWlc>

Lifespan Fitness Channel:  
<http://www.youtube.com/user/treadmillsvideos>

# 6. OPERATION GUIDE

## 1. OVERVIEW

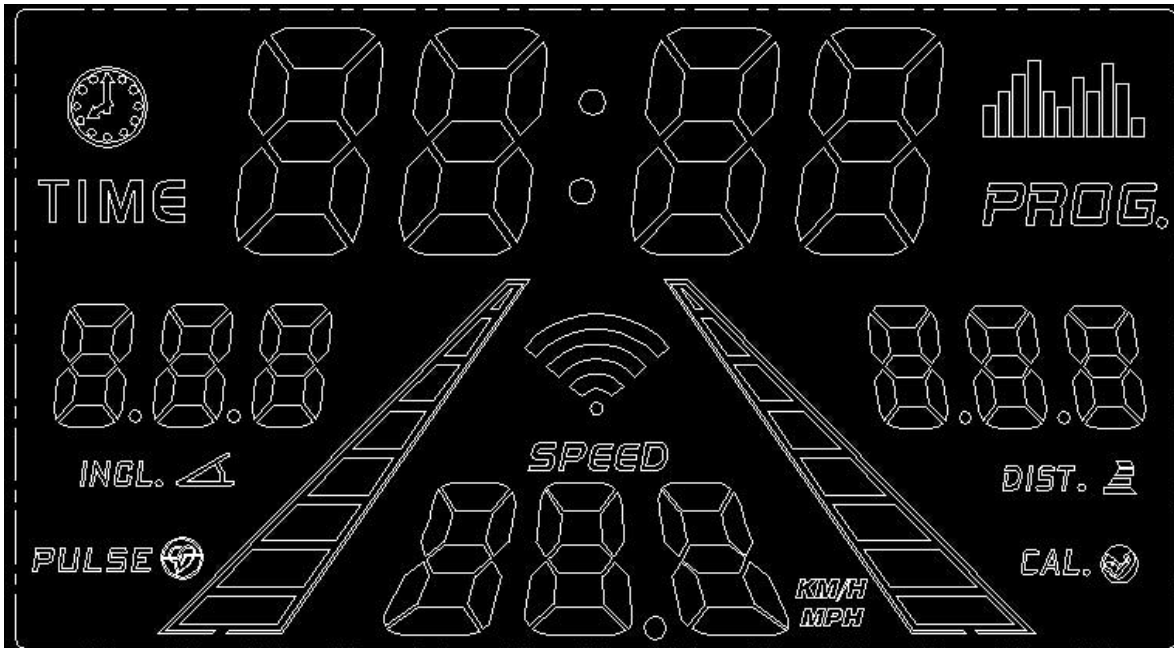

## 2. LCD WINDOW DISPLAY

1. **Speed window:** Shows speed and programs
2. **Time window:** Shows time
3. **DIS window:** shows distance
4. **CALO window:** shows calories
5. **Pulse:** shows the heart rate. When you hold the hand pulse sensor the window will show your heart rate. Heart rate data is for reference ONLY.

## 3. BUTTON FUNCTIONS

**“PROGRAM” button:** Press this button to choose a program. Choose from manual mode, preset programs (P1 - P12) and body fat tester (FAT).

**“MODE” button:** Press this button to choose a mode, Choose form time count down, distance count down and calories count down;

**“START” button:** Press this button to start the machine. The machine will start at the lowest speed or at the

speed of the default program after a 3 second time count down.

**“STOP” button:** Press this button to stop the machine, the machine will stop smoothly;

**SPEED ▲, ▼:** Adjusts the speed. Press these buttons to adjust the speed when running and adjust the data when stopped/

**SPEED (2, 4, 6, 8, 10, 12):** Adjust the speed quickly to the specified value

**Left handle bar buttons:** Start and stop button;

**Right handle bar buttons:** Adjusts speed;

### 3. MAIN FUNCTIONS

#### 3.1. Quick Start-up (Manual):

Attach the safety key. After a 3 second countdown, the treadmill will starting and running from the lowest speed, add and subtract to the speed using the SPEED button.

#### 3.2. Countdown mode:

Press the MODE button to cycle options: time countdown, distance countdown, calories countdown. The default value corresponds to the window and flashing display. At this point the SPEED buttons serve as a plus and minus functions to adjust to the desired value. Press the START, add and subtract speed by using SPEED buttons once again. When the countdown reaches 0, the machine will stop. You can also directly press the STOP button or disconnect safety lock to stop.

#### 3.3. Preset programs:

Press the program button; programs from P1 to P12 are built-in programs. The time window displays the default value of TIME. When flashing, press the SPEED buttons to adjust to your desired time. Built-in program are divided into 20 equal segments. After pressing the START button, the treadmill will automatically cycle through the time segments. Speed will automatically adjust to the preset value for the segment. Upon completion of the segments, the program will end, slowing the treadmill down to a stop. During the operation speed can be adjusted but the next segment will be automatically adjusted to the program defaults. Built-in program data is listed on the table.

#### 4. VALUE RANGE:

SET RANGE	INITIAL	DEFAULT INITIAL DATA	DEFAULT RANGE	RANGE DISPLAY
TIME	0:00	15:00	5:00-99:00	0:00—99:59
SPEED (KM/H)	---	---	---	0. 8-14
DISTANCE(KM)	0	1.00	0. 5-99.9	0.00—99.9
HEART RATE	P	N/A	N/A	50-200
CALORIES	0	50.0	10.0-999	0—999

#### 5. HEART RATE:

When holding the hand pulse with two hands, the pulse window will show your heart rate after 5 seconds.

To increase accuracy please check heart rate with the machine stopped and after keeping your hands on the sensors for more than 30 seconds.

**The heart rate data is for reference purposes ONLY.**

#### 6. PROGRAM CHART

PROGRAM \ TIME		Total set time = 1/10 <sup>th</sup> of the running time of each period																			
		1	2	3	4	5	6	7	8	9	1	1	1	1	1	1	1	1	1	19	20
P01	SPEED	2	3	3	4	5	3	4	5	5	3	4	5	4	4	4	2	3	3	5	3
P02	SPEED	2	4	4	5	6	4	6	6	6	4	5	6	4	4	4	2	2	5	4	2
P03	SPEED	2	4	4	6	6	4	7	7	7	4	7	7	4	4	4	2	4	5	3	2
P04	SPEED	3	5	5	6	7	7	5	7	7	8	8	5	9	5	5	6	6	4	4	3
P05	SPEED	2	4	4	5	6	7	7	5	6	7	8	8	5	4	3	3	6	5	4	2
P06	SPEED	2	4	4	4	5	6	8	8	6	7	8	8	6	4	4	2	5	4	3	2
P07	SPEED	2	3	3	3	4	5	3	4	5	3	4	5	3	3	3	6	6	5	3	3
P08	SPEED	2	3	3	6	7	7	4	6	7	4	6	7	4	4	4	2	3	4	4	2
P09	SPEED	2	4	4	7	7	4	7	8	4	8	9	9	4	4	4	5	6	3	3	2
P10	SPEED	2	4	5	6	7	5	4	6	8	8	6	6	5	4	4	2	4	4	3	3
P11	SPEED	2	5	8	1	7	7	1	1	7	7	1	1	5	5	9	9	5	5	4	3
P12	SPEED	3	4	9	9	5	9	5	8	5	9	7	5	5	7	9	9	5	7	6	3

## 7. BODY FAT TESTER

Press "PROGRAM" until the window displays "FAT".

Press "MODE" to select parameters after entering data (F1 = "SEX", F2 = "AGE", F3 = "HEIGHT", F4 = "WEIGHT").

Use "SPEED+/-" to set data. After entering all data the window will display "F5".

Place both hands on the hand sensors for 5 seconds, and the window will display your body fat data.

### Input parameter display and setting limits

	PARAMETERS	ARRANGEMENT	NOTE
F-1	SEX	01--02	01= MALE 02= FEMALE
F-2	AGE	10—99 YEARS	
F-3	HEIGHT	100—200 CM	
F-4	WEIGHT	20—150 KGS	

FA (BMI)	RESULT
≤19	UNDER WEIGHT
20--25	NORMAL WEIGHT
25--29	OVER WEIGHT
≥30	OBESE

## 8. SLEEP FUNCTION:

The treadmill automatically enters sleep mode after 10 minutes of inactivity. Press any key on the display to wake the treadmill.

## 7. EXERCISE GUIDE

**PLEASE NOTE:** Before beginning any exercise program, consult your physician. This is important especially if you are over the age of 45 or individuals with pre-existing health problems.

The pulse sensors are not medical devices. Various factors, including the user's movement, may affect the accuracy of heart rate readings. The pulse sensors are intended only as an exercise aid in determining heart rate trends in general.

Exercising is great way to control your weight, improving your fitness and reduce the effect of aging and stress. The key to success is to make exercise a regular and enjoyable part of your everyday life.

The condition of your heart and lungs and how efficient they are in delivering oxygen via your blood to your muscles is an important factor to your fitness. Your muscles use this oxygen to provide enough energy for daily activity. This is called aerobic activity. When you are fit, your heart will not have to work so hard. It will pump a lot fewer times per minute, reducing the wear and tear of your heart.

So as you can see, the fitter you are, the healthier and greater you will feel.

### Warm-up

Start each workout with 5 to 10 minutes of stretching and some light exercises. A proper warm-up increases your body temperature, heart rate and circulation in preparation for exercise. Ease into your exercise.

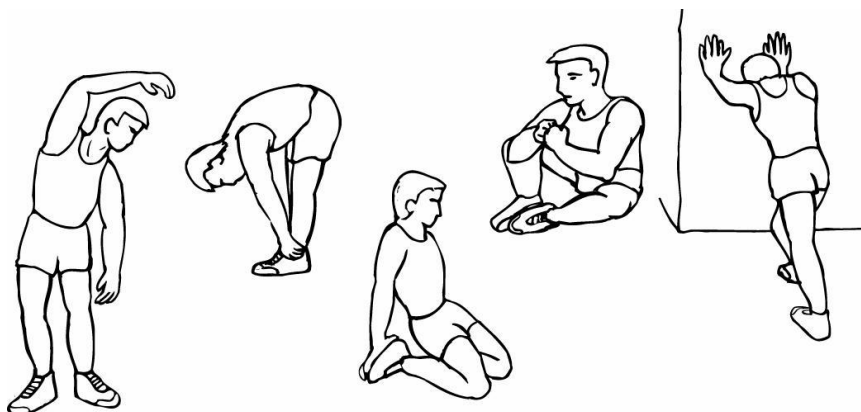

## Training Zone Exercise

After warming up, increase the intensity to your desired exercise program. Be sure to maintain your intensity for maximum performance. Breathe regularly and deeply as you exercise-never hold your breath.

## Cool Down

Finish each workout with a light jog or walk for at least 1 minute. Then complete 5 to 10 minutes of stretching to cool down. This will increase the flexibility of your muscles and will help prevent post-exercise problems.

## Workout Guidelines

### TARGET ZONE

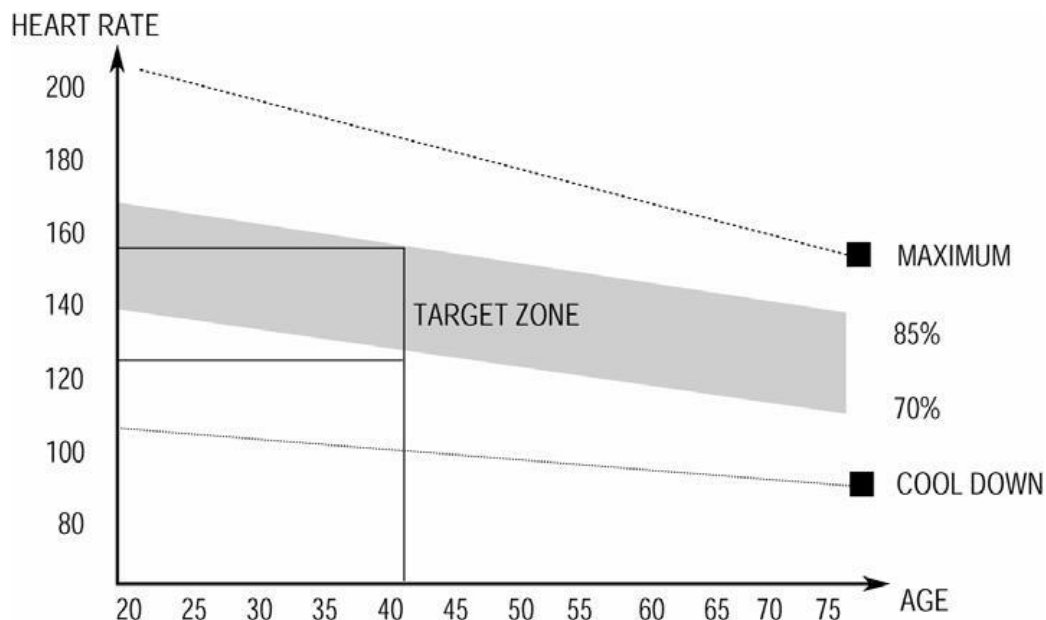

**THIS IS HOW YOUR PULSE SHOULD BEHAVE DURING GENERAL FITNESS EXERCISE.**

**REMEMBER TO WARM UP AND COOL DOWN FOR A FEW MINUTES.**

The most important factor here is the amount of effort you put in. The harder and longer you work, the more calories you will burn. Effectively this is the same as if you were training to improve your fitness, the difference is the goal.



## 8. MAINTENANCE INSTRUCTIONS

Reasonable cleaning/lubricating should be made to extend the life time of this unit. Performance is maximized when the belt and mat are kept as clean as possible.

**WARNING: THE MAT/DECK FRICTION MAY PLAY A MAJOR ROLE IN THE FUNCTION AND LIFE OF YOUR TREADMILL AND THAT IS WHY WE RECOMMEND YOU CONSTANTLY LUBRICATE THIS FRICTION POINT TO PROLONG THE USEFUL LIFE OF YOUR TREADMILL. FAILING TO DO THIS MAY VOID YOUR WARRANTY.**

**WARNING: UNPLUG POWER CORD BEFORE MAINTENANCE**

**WARNING: STOP TREADMILL BEFORE FOLDING**

### 1. General Cleaning

- Use a soft, damp cloth to wipe the edge of the belt and the area between the belt edge and frame. A mild soap and water solution along with a nylon scrub brush will clean the top of the textured belt. This task should be done once a month. Allow to dry before using.
- On a monthly basis, vacuum underneath your treadmill to prevent dust build up. Once a year, you should remove the black motor shield and vacuum out dirt that may accumulate.

### 2. General Care

- Check parts for wear before use.
- Pay particular attention to the fixing knobs and make sure they are tight.
- Always replace the mat if worn and any other defective parts.

- If in doubt do not use the treadmill and contact us.

TAKE CARE TO PROTECT CARPETS AND FLOOR in case of leakages. This product is a machine that contains moving parts which have been greased / lubricated and could leak.

### 3. Belt/Deck/Roller Lubrication

The mat/deck friction may play a major role in the function and life of your treadmill and that is why we recommend you constantly lubricate this friction point to prolong the useful life of your treadmill. You should apply lubrication after approximately the first 30 hours of operation. We recommend lubrication of the deck according to the following timetable:

- Light use (less than 3 hours per week) every 6 months
- Medium use (3-5 hours a week) every 3 months
- Heavy use (more than 5 hours per week) every 6-8 weeks

See below procedures for lubricating:

1. Use a soft, dry cloth to wipe the area between the belt and deck.
2. Spread lubricant onto the inside surface of belt and deck evenly (make sure the machine is turned off and power is disconnected).

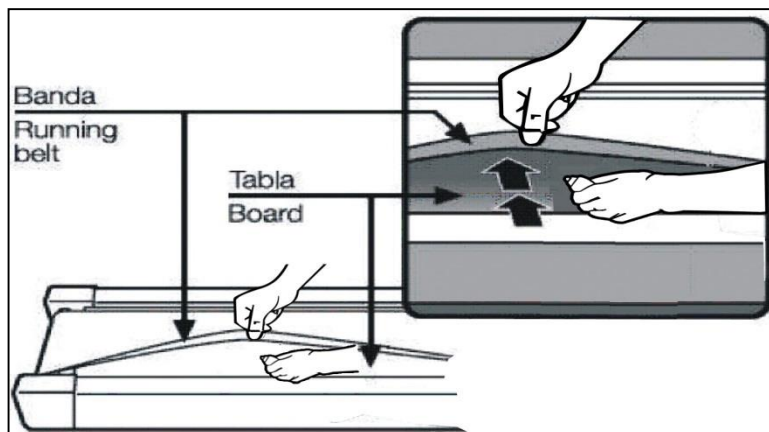

3. Periodically lubricate the front and rear rollers to keep them at their peak performance. If the treadmill belt/deck/roller is kept reasonably clean it is possible to expect over 1200 hours before relubricating is necessary.

#### **4. How to check the running mat for proper lubrication:**

1. Disconnect the main power supply.
2. Fold the treadmill up into the storage position.
3. Feel the underside surface of the running mat.

If the surface is slick when touched, then no further lubrication is needed.

If the surface is dry to the touch, apply a suitable silicone lubricant.

**We recommend that you use a silicone based spray to lubricate your Lifespan treadmill. This can be purchased directly from us or any hardware store.**

## 5. Adjusting the Running Belt

Place treadmill on a level surface. Run treadmill at approximately 4km/h, checking the running condition.

---

If the belt has drifted to the **right**:

Whilst the treadmill is running at 4km/h, carefully turn the **right** adjusting bolt 1/4 turn **clockwise**. Then monitor treadmill until the belt centers. Repeat until the belt correctly centers.

See *Picture A*

If you have over adjusted the belt and it drifts to the right, carefully turn the **right** adjusting bolt **anticlockwise** until the belt centers.

---

If the belt has drifted to the **left**:

Whilst the treadmill is running at 4km/h, carefully turn the **left** adjusting bolt 1/4 turn **clockwise**. Then monitor treadmill until the belt centers. Repeat until the belt correctly centers.

See *Picture B*

If you have over adjusted it, carefully turn the **left** adjusting bolt **anticlockwise** and until the belt centers.

---

To adjust the **tightness** of the belt:

Turn the treadmill off. Turn both the left and right adjusting bolts 1/4 turn clockwise. Repeat until the belt correctly tightens.

See *Picture C*

If the belt is over tightened, simply do the opposite to loosen.

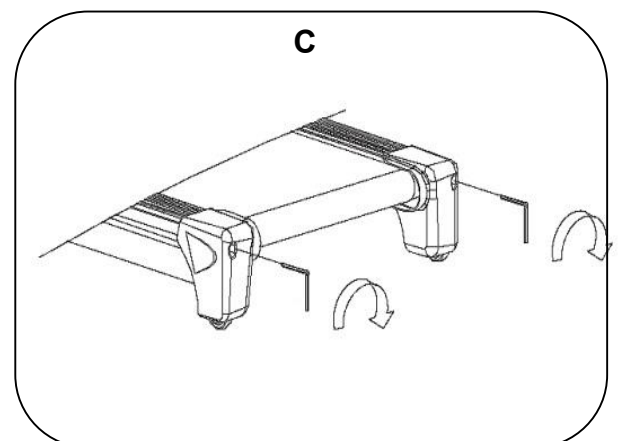
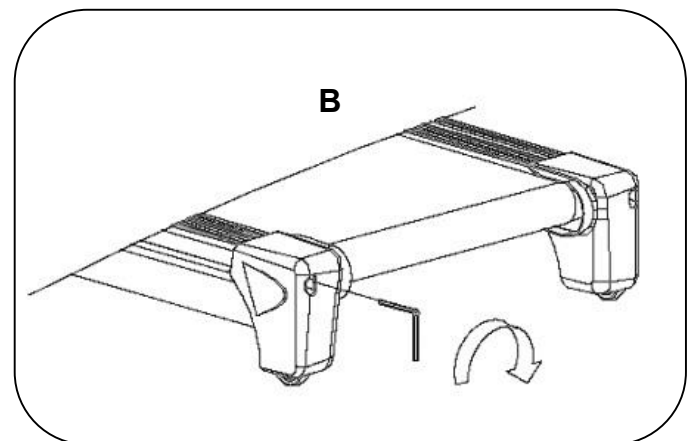
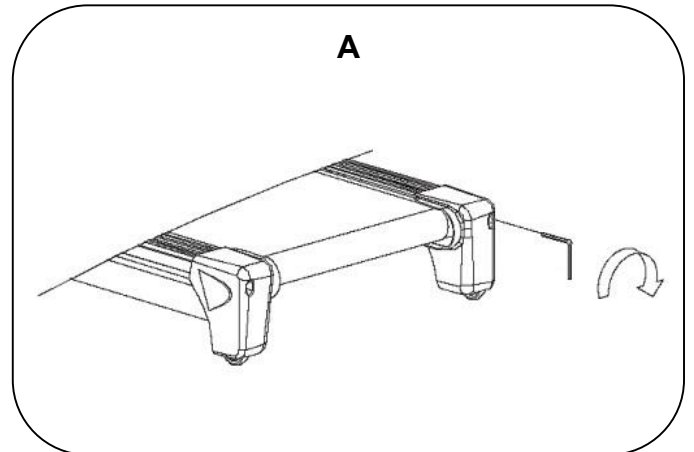

**NOTE:** When properly tightened, you should be able to peel the very edge of the side of the belt up approximately 2 inches. However this is a rough reference and not all treadmills are the same. Some treadmills that have longer belts may give different measurements for correct belt tightness.

Simply, if the belt begins to slip during use, this is an indication that the belt still needs tightening.

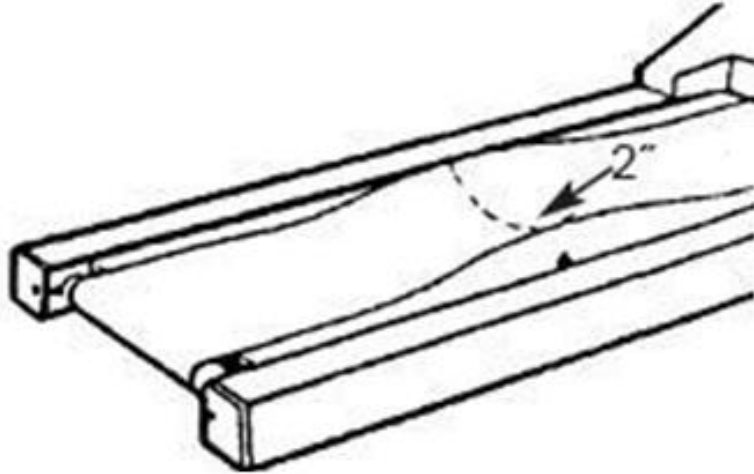

**Video Tutorial Available at:**  
<http://youtu.be/vlsamTSvvA>

**Lifespan Fitness Channel:**  
<http://www.youtube.com/user/treadmillsvideos>

## 6. Replacing Motor Brushes

After extended use, the motor brushes in your treadmill motor will wear down, and this can lead to motor failure. It is important that you maintain your motor by replacing the brushes on either side of the motor when they are worn down. We recommend that you check your motor every 1000 hours of usage.

**IMPORTANT:** Before beginning the replacement of your motor brush, ensure that the treadmill is off and unplugged from the electrical socket.

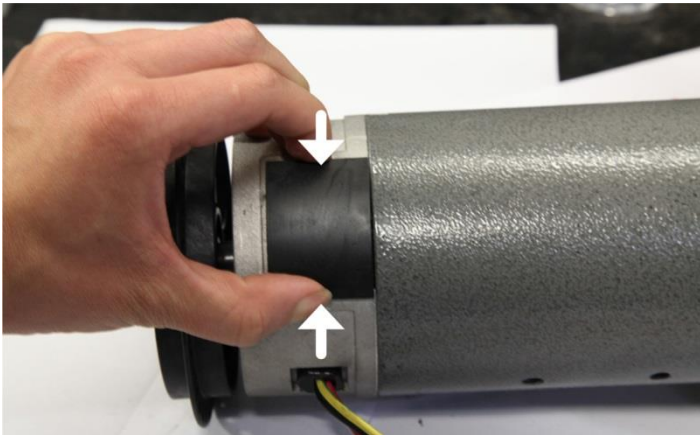

1. Remove the cover from the motor by squeezing it from the sides.

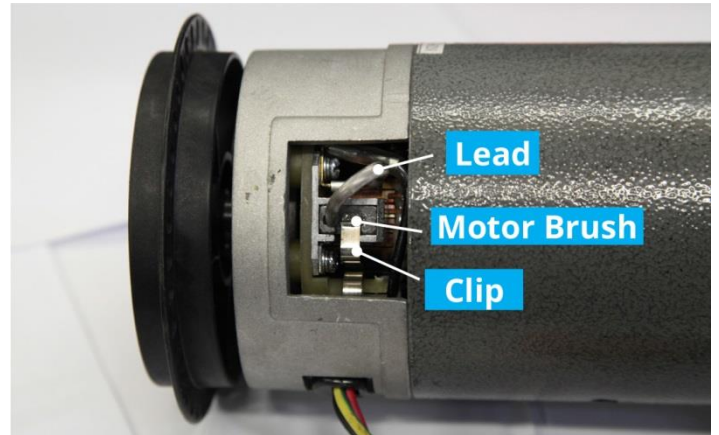

2. You'll find the motor brush held in with a clip, with the lead plugged in.

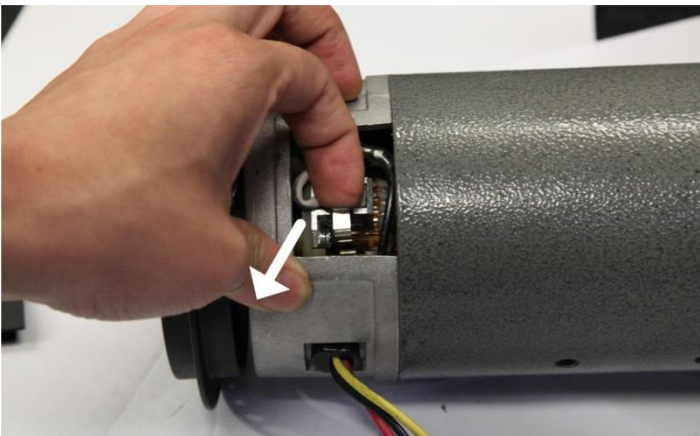

3. Pull the clip out from its position.

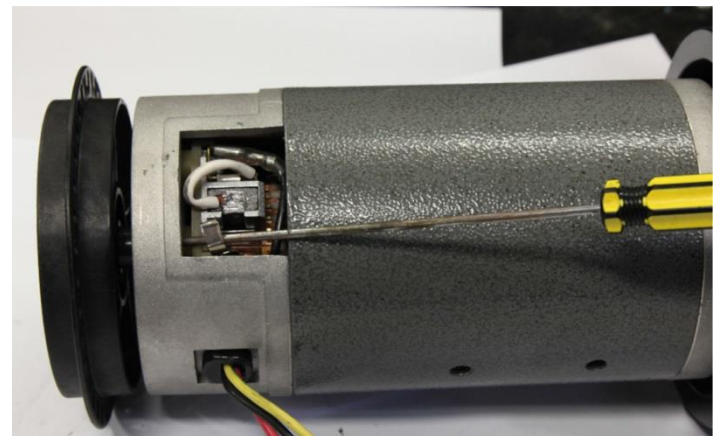

4a. Hold the clip out of the way with a screwdriver or similar object. Keep the screwdriver in this position until step 9.

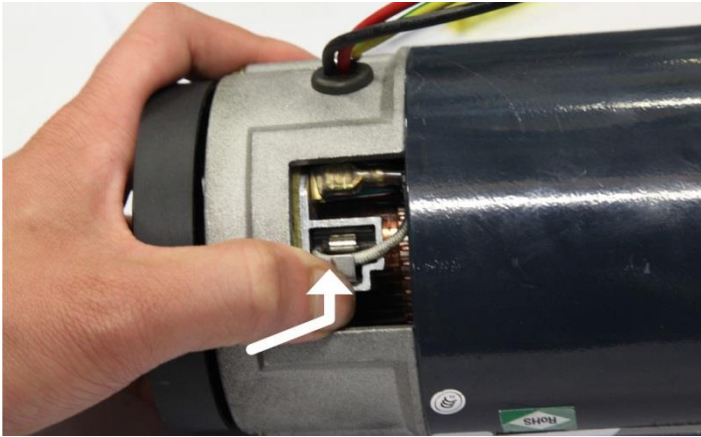

**4b.** Some treadmill motors may use a push clip instead. In this case, gently push the clip inwards and then up to release it from its latch.

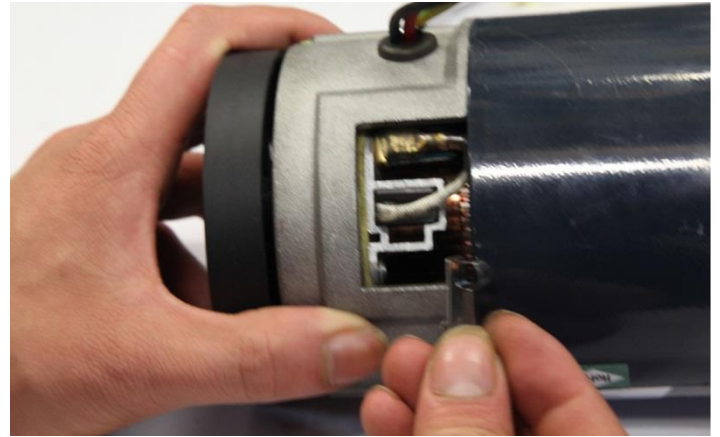

**4c.** Remove the clip, noting the direction in which it was originally placed, and put it safely aside.

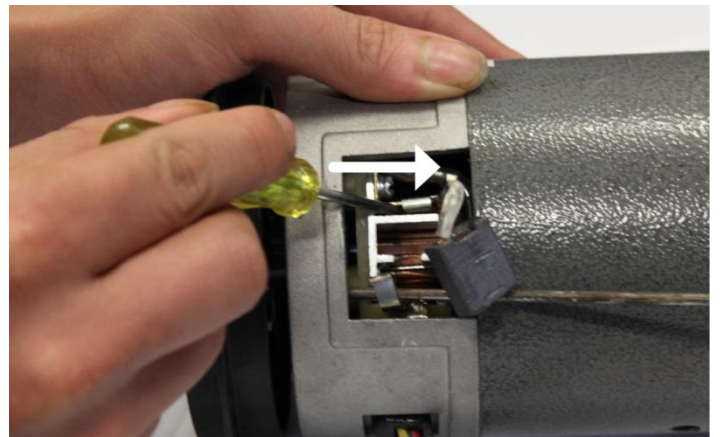
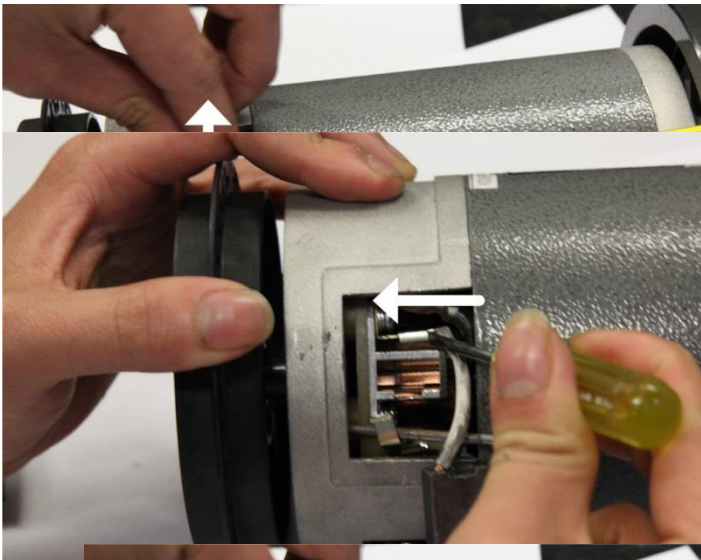

**6.** Slide the motor brush lead off the terminal using another small screwdriver or needle-nosed pliers.

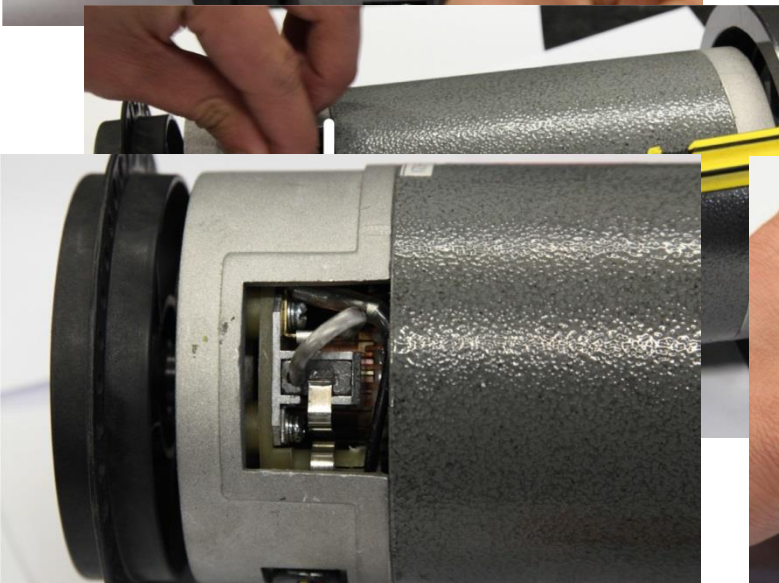

**9a.** Release the clip back into its position.

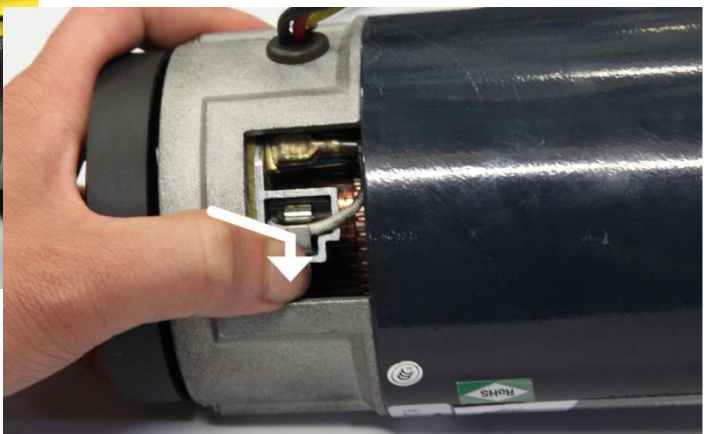

**9b.** If your motor uses a push clip, replace the push clip by pushing it inwards and then down so that it engages the catch.

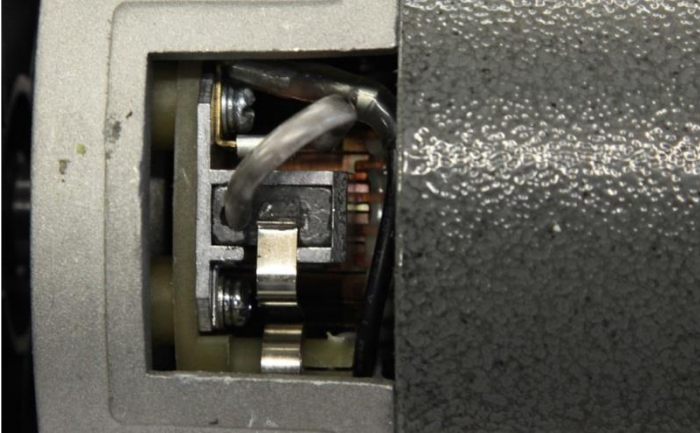

**10.** Check that the motor brush is held firmly in place by the clip, and that the lead is plugged securely onto the terminal.

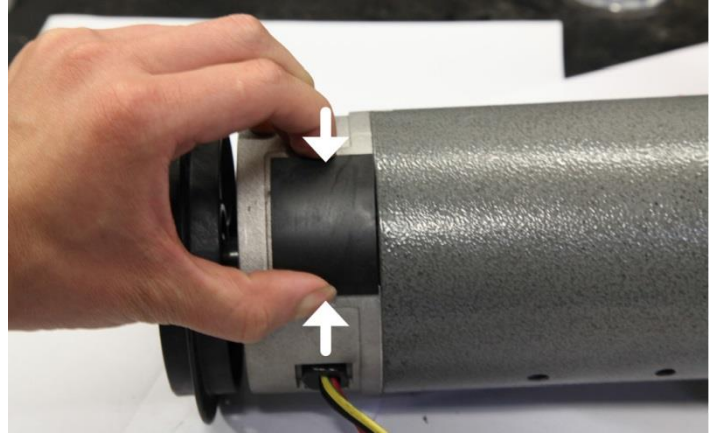

**11.** Replace the motor cover. Repeat steps 1-15 for the second brush located on the opposing side of the motor.

**12.** You have now successfully replaced the motor brushes. We also recommend that you remove any dirt and dust from your treadmill motor fan using a vacuum cleaner before replacing the cover.



# 9. EXPLODED DIAGRAM

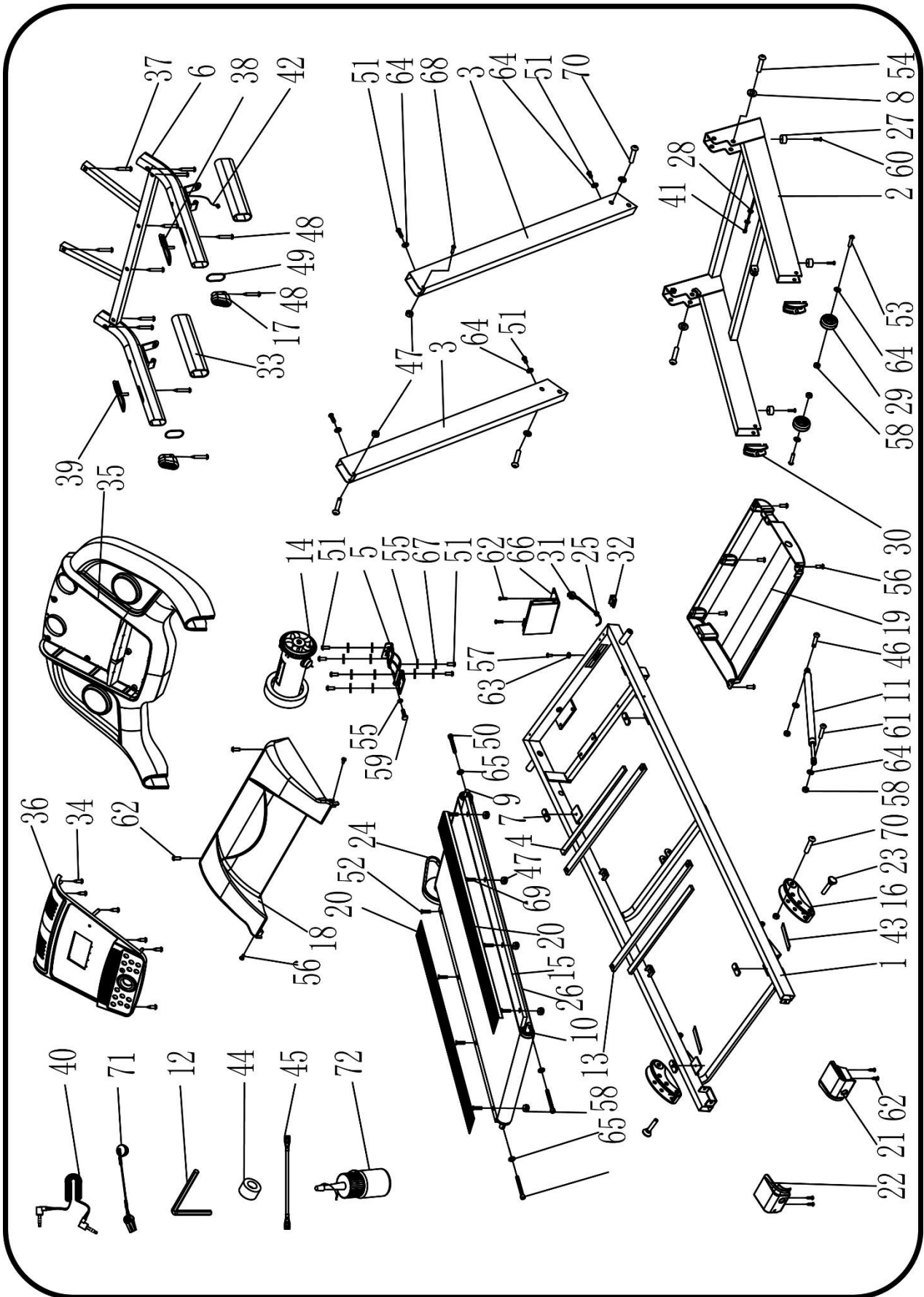

## 10. PARTS LIST

#	DESCRIPTION	REMARK	QTY	#	DESCRIPTION	REMARK	QTY
1	Main Frame		1	38	Speed+-Key		1
2	Base Frame		1	39	START/STOP Key		1
3	Upright Tube		2	41	Computer bottom cover		1
4	EVA mat	375*20*3	2	42	Computer up cover		1
5	Motor Bracket		1	43	Rubber pad 2		2
6	Computer Bracket		1	44	Magnetic ring		1
7	Rubber pad1		4	45	Blue single wire		1
8	Lock Washer	10	2	46	Bolt	M8*25	1
9	Front Roller		1	47	Screw	M6	6
10	Rear Roller		1	48	Bolt	ST4.2*45	2
11	Cylinder		1	49	Decorating ring		2
12	5#Allen wrench	5mm	1	50	Bolt	M6*65	3
13	Running Board Strengthen Tube		2	51	Bolt	M8*16	8
14	DC Motor		1	52	Bolt	M8*12	2
15	Running Board		1	53	Bolt	M8*40	2
16	Adjustable foot pad		2	54	Bolt	M10*55	2
17	Inner circle end cap		2	55	Flat washer	8	7
18	Motor up cover		1	56	Bolt	ST4.2*12	5
19	Motor bottom cover		1	57	Bolt	M5*8	5
20	Side rails		2	58	Screw	M8	6
21	Right back end cover		1	59	Bolt	M8*25	1
22	Left back end cover		1	60	Bolt	ST4.2*19	4
23	Fixing plug		2	61	Running board strengthening tube		2
24	Motor belt		1	62	Bolt	ST4.2*19	4
25	Power wire buckle		1	63	Lock washer	5	1
26	Running belt		1	64	Lock washer	8	8
27	Foot pad		4	65	Lock washer	6	3
28	Ring wire protector		2	66	Bolt	M8*42	1
29	transportation wheel		2	67	Spring lock washer	8	6
30	Moving wheel cover		2	68	Bolt	M6*27	2
31	Standard power wire		1	69	Bolt	M6*25	4
32	switch		1	70	Bolt	M8*45	4
33	foam		2	71	Safety key		1
34	Bolt	ST4.2*13	9	72	Oil bottle		1
35	Computer bottom cover		1	73	Bolt	M6*28	4
36	Computer sealing board		1	74	Bolt	ST4.8*19	2
37	Screw driver	ST4.2*20	8				

# 11. TROUBLE SHOOTING GUIDE

CODE	SOLUTION
E01	<b>Reason:</b> signal failure within the connection between computer and controller
	<b>Solution:</b> A. Check that the wires connecting the computer and controller are not damaged and are connected well. B. Replace the IC of controller or computer.
E02	<b>Reason:</b> The voltage of the motor is not detected by controller
	<b>Solution:</b> A. Check whether the positive and negative line of motor are successfully connected with the controller terminal interface B. Check if the power tube on the controller and peripheral components are damaged C. Consider replacing controller or motor
E03	<b>Reason:</b> Speed feedback is not detected by controller when motor is running
	<b>Solution:</b> A. Check if the motor rotates when the machine starts before displaying E03. If so, conduct the following checks. 1. Check that the speed sensor is attached well. 2. Check that the speed sensor wires are not damaged 3. Check that the interface between light sensor and 4 white pin on the controller is connected well 4. Check if the peripheral area of the four white pin is damaged 5. Consider replacing controller and IC B. If the motor does not running when you start the machine and E03 shows, check if the motor is stuck. If the problem persists, consider replacing the motor.
E05	<b>Reason:</b> The voltage is over the protection value when the motor is running.
	<b>Solution:</b> A. Check if the motor is in good condition, and if there anything stuck in running belt or roller so as to unnaturally increase the resistance of for the motor. B. Replace the controller

<b>E07</b>	<b>Reason:</b> The signal of the safety key is not detected by the computer so as to show E07 or “— — —”
	<b>Solution:</b> A. Check the magnetic parts of the safety key are in contact with the treadmill B. Open the computer, check safety switch line plug and check for safety switch board damage and that the plug is in position.
<b>Unable to control speed</b>	<b>Solution:</b> Refer to E03
<b>No Power</b>	<b>Solution:</b> A. Check the fuse B. Check that the power plug terminal is in good contact with the controller.
<b>Abnormal motor torque</b>	<b>Solution:</b> A. Check whether the motor condition and motor belt tension. Replace motor if necessary B. If motor is in good condition, replace control board or IC.
<b>Motor burnt out</b>	<b>Solution:</b> A. Check if the control is also burnt. B. Replace the motor C. Replace the controller
<b>Incline cannot be controlled</b>	<b>Solution:</b> A. Check incline motor power wire and 3pin line connection with controller 1. Remove the computer wire installed on the controller (safety lock), turn on the power, press down on the small key on the right corner of controller 2 seconds 2. The incline motor will initiate an automatic signal detection procedure. The motor will ascend to the highest level then descend to the lowest level 3. When the motor reaches the lowest level, after 3 seconds, the procedure will be over. 4. After the procedure, connect the computer wire (or the safety key). Operate the computer function and test the incline function B. Change the controller
<b>Power interruption</b>	<b>Solution:</b> A. Check if the power wire is connected well B. Check wire – controller connection
<b>No display appearing on LCD</b>	<b>Solution:</b> A. Check if the voltage is correct B. Check that the electronic power supply is 8V C. Change the controller D. Change the computer

<b>LCD screen flashing</b>	<b>Solution:</b> A. Check if the voltage is correct B. Check that the electronic power supply is 8V C. Change the controller D. Change the computer
<b>LCD display faulty</b>	<b>Solution:</b> 1. Turn off power supply 2. Repower the motor, observe if normal or not 3. If not, remove computer and fixed PCB. Check for damage 4. If no damage clean the PCB gold finger position and retest
<b>LCD displaying but with dysfunction</b>	<b>Solution:</b> A. Turn off power supply and repower the motor B. Change the computer.
<b>backlight is not bright</b>	<b>Solution:</b> A. Turn off the power supply and repower the motor. B. Start the computer, check if all wires are connected well. Check for backlight damage C. Change the computer
<b>A button is not functioning</b>	<b>Solution:</b> A. If only one key is not working, open the computer and check the button for damage B. Replace the computer
	A. If most keys do not work, restart the treadmill B. Replace the computer
<b>Pulse function is unresponsive</b>	<b>Solution:</b> A. Wash your hands, test again B. Check for damage to the pulse sensor cables as well as the connection terminal C. Change PCB or computer

## 12. WARRANTY

### AUSTRALIAN CONSUMER LAW

*Many of our products come with a guarantee or warranty from the manufacturer. In addition, they come with guarantees that cannot be excluded under the Australian Consumer Law. You are entitled to a replacement or refund for a major failure and compensation for any other reasonably foreseeable loss or damage.*

*You are entitled to have the goods repaired or replaced if the goods fail to be of acceptable quality and the failure does not amount to a major failure. Full details of your consumer rights may be found at [www.consumerlaw.gov.au](http://www.consumerlaw.gov.au)*

Please visit our website to view our full warranty terms and conditions:

<http://www.lifespanfitness.com.au/warranty-repairs>

### **Warranty and Support:**

Please email us at [support@lifespanfitness.com.au](mailto:support@lifespanfitness.com.au) for all warranty or support issues.

For all warranty or support related enquiries an email must be sent before contacting us via any other means.

# Hand Pulse Technology

Lifespan Fitness Treadmills come equipped with hand pulse sensors which are used to pick up tiny EKG/ECG signals that run through the body when your heart beats. These electrical EKG/ECG signals are very small and that they must be amplified 1000 times to make the signal useful for the computer to display your pulse.

To ensure proper operation:

- The user must maintain good, consistent contact on all four sensors
- The users skin cannot be too dry or too wet

Other factors that could affect the reading:

- Change of grip on the sensors (during slow pace walking and up to running)
- Tightening of hand muscles will produce small electrical signals
- Static electricity charges from the air or from walking on the treadmill

EKG/ECG Sensors may filter through actual EKG/ECG signals and “Noise” factors that may affect the reading. This will cause the pulse reading to be delayed and will take longer to update the display as the heart rate changes. Too much noise will create an incorrect reading. Medical conditions or having no electrical signal in the hands are other factors that may affect pulse readings as well.

These are limitations of hand pulse technology and even the most expensive systems (which can cost upwards of \$3,000) used in hospitals have the same problems. The difference is that a patient in a hospital is not running on a treadmill. Hand pulse technology works well on stationary exercise machines like bikes and even elliptical cross trainers but are not perfect on a treadmill. We offer treadmills with a wireless heart rate receiver which may be a more accurate option.

To test if your hand pulse sensors are working up to specification, hold them while standing on the side step rails, not walking, and see if the reading is more in line with what you would expect. This will eliminate the movement and static electricity factors. If your hands are dry, then wet them slightly (saliva works as a great conductor if this doesn't bother you).

For more information, please contact our Lifespan Technical Support Department

[www.lifespanfitness.com.au](http://www.lifespanfitness.com.au)

[support@lifespanfitness.com.au](mailto:support@lifespanfitness.com.au)