



PREMIER OWNER'S MANUAL



Product may vary slightly from the item pictured due to model upgrades

Read all instructions carefully before using this product. Retain this owner's manual for future reference.

TABLE OF CONTENTS

1.	IMPORTANT SAFETY INSTRUCTIONS	3
2.	IMPORTANT ELECTRICAL INFORMATION	4
3.	IMPORTANT OPERATING INSTRUCTIONS	5
4.	ASSEMBLY INSTRUCTIONS	6
5.	GROUNDING METHODS	9
6.	OPERATION GUIDE	10
7.	USAGE GUIDE	12
8.	EXERCISE GUIDE	14
9.	MAINTENANCE INSTRUCTIONS	16
10.	WARRANTY	20
11.	PROGRAM TABLES	21

1. IMPORTANT SAFETY INSTRUCTIONS

WARNING - Read all instructions before using this treadmill.

It is important your treadmill receives regular maintenance to prolong its useful life. Failing to regularly maintain your treadmill may void your warranty.

Danger – To reduce the risk of electric shock disconnect your treadmill from the electrical outlet prior to cleaning and/or service work.

DO NOT USE AN EXTENSION CORD: DO NOT ATTEMPT TO DISABLE THE GROUNDED PLUG BY USING IMPROPER ADAPTERS OR IN ANY WAY MODIFY THE CORD SET.

- Install the treadmill on a flat level surface with access to a 220-240 volt (50/60Hz), grounded outlet.
- Do not operate treadmill on deeply padded, plush or shag carpet. Damage to both carpet and treadmill may result.
- Do not block the rear of the treadmill. Provide a minimum of 1 metre clearance between the rear of the treadmill and any fixed object.
- Place your unit on a solid, level surface when in use
- Never allow children on or near the treadmill.
- When running, make sure the plastic clip is fastened on your clothing. It is for your safety, should you fall or move too far back on the treadmill.
- Keep hands away from all moving parts.
- Never operate the treadmill if it has a damaged cord or plug.
- Keep the cord away from heated surfaces.
- Do not operate where aerosol spray products are being used or where oxygen is being administered. Sparks from the motor may ignite a highly gaseous environment.
- Never drop or insert any object into any openings.
- The treadmill is intended for in-home use only and not suitable for long time running.

- To disconnect, turn all controls to the off position, remove the safety key, and then remove the plug from the outlet.
- The pulse sensors are not medical devices. Various factors, including the user's movement, may affect the accuracy of heart rate readings. The pulse sensors are intended only as exercise aids in determining heart rate trends in general.
- Use the handrails provided; they are for your safety.
- Wear proper shoes. High heels, dress shoes, sandals or bare feet are not suitable for use on your treadmill. Quality athletic shoes are recommended to avoid leg fatigue.
- Allowed temperature: 5 to 40 degrees.

Remove the safety key after use to prevent unauthorized treadmill operation.

2. IMPORTANT ELECTRICAL INFORMATION

WARNING!

- NEVER use a ground fault circuit interrupt (GFCI) wall outlet with this treadmill. Route the power cord away from any moving part of the treadmill including the elevation mechanism and transport wheels.
- NEVER remove any cover without first disconnecting AC power.
- NEVER expose this treadmill to rain or moisture. This treadmill is not designed for use outdoors, near a pool, or in any other high humidity environment.

3. IMPORTANT OPERATING INSTRUCTIONS

- Be sure to read the entire manual before operating your machine.
- Understand that changes in speed and incline do not occur immediately. Set your desired speed on the computer console and release the adjustment key. The computer will obey the command gradually.
- Use caution while participating in other activities while walking on your treadmill, such as watching television, reading, etc. These distractions may cause you to lose balance or stray from walking in the centre of the belt; which may result in serious injury.
- In order to prevent losing balance and suffering unexpected injury, **NEVER** mount or dismount the treadmill while the belt is moving. This unit starts with at a very low speed. Simply standing on the belt during slow acceleration is proper after you have learned to operate this machine.
- Always hold on to handrail while making control changes.
- A safety key is provided with this machine. Remove the safety key will stop the walking belt immediately; the treadmill will shut off automatically. Inserting the safety key will reset the display.
- Do not use excessive pressure on console control keys. They are precision set to function properly with little finger pressure.

4. ASSEMBLY INSTRUCTIONS

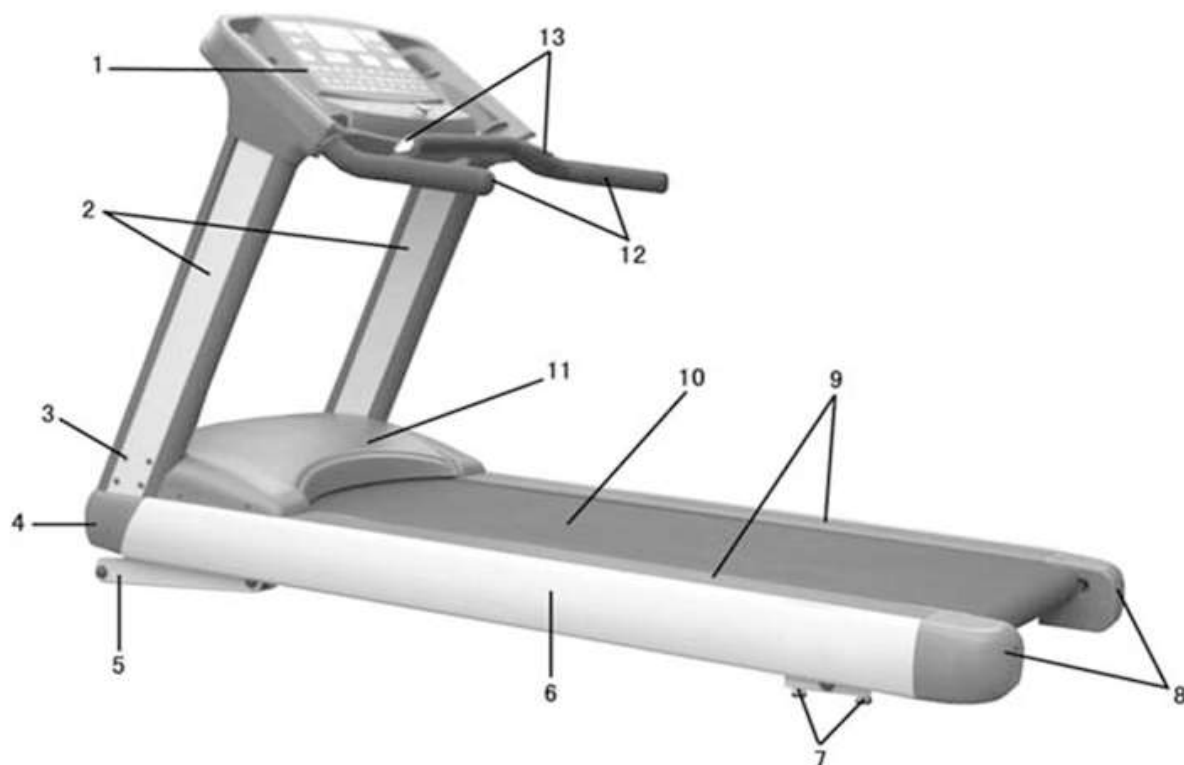

1	Monitor	9	Footboard covering
2	Support	10	Belt
3	Bolt for fixing support	11	Motor covering
4	Front covering	12	Handrail
5	Up-down leg	13	Handrail Sensor
6	Side footboard		
7	Adjusting bolt		
8	Adjuster		

PART LIST

No.	Name of spare parts	Quantity	No.	Name of spare parts	Quantity
1	main body	1	11		
2	monitor	1	12		
3	support	2	13		
4	φ28 Pipe plug	4	14		
5	M8*20 flat head bolt	12	15		
6	φ8 flat gasket	8	16		
7	special tools	3sef	17		
8	manual book	1	18		
9	quality certificate	1	19		
10	Guarantee card	1	20		

STEP 1:

Pull cable through support



STEP 2:

Connect left and right with main body



STEP 3:

Connect monitor with support



STEP 4:

Connect 7-pin cable with monitor



5. GROUNDING METHODS

This product must be grounded. In the event of malfunction or breakdown, grounding reduces the risk of electric shock. This product is equipped with a cord with an equipment-grounding conductor and a grounding plug. The plug must be plugged into an appropriate outlet that is properly installed and grounded in accordance with all local codes and ordinances.

DANGER

Improper connection of the equipment-grounding conductor can result in risk of electric shock.

Check with a qualified electrician or serviceman if you are in doubt as to whether the product is properly grounded.

Do not modify the plug provided with the product – if it will not fit the outlet; have a proper outlet installed by a qualified electrician.

This product is for use on a nominal 240-volt circuit and has a grounding plug that looks like the plug illustrated in sketch A in following figure. Ensure the product is connected to an outlet having the same configuration as the plug. No adapter should be used with this product.

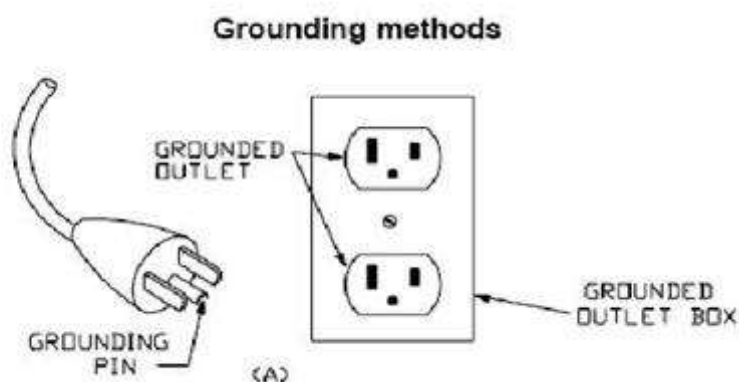

6. OPERATION GUIDE

1. OVERVIEW

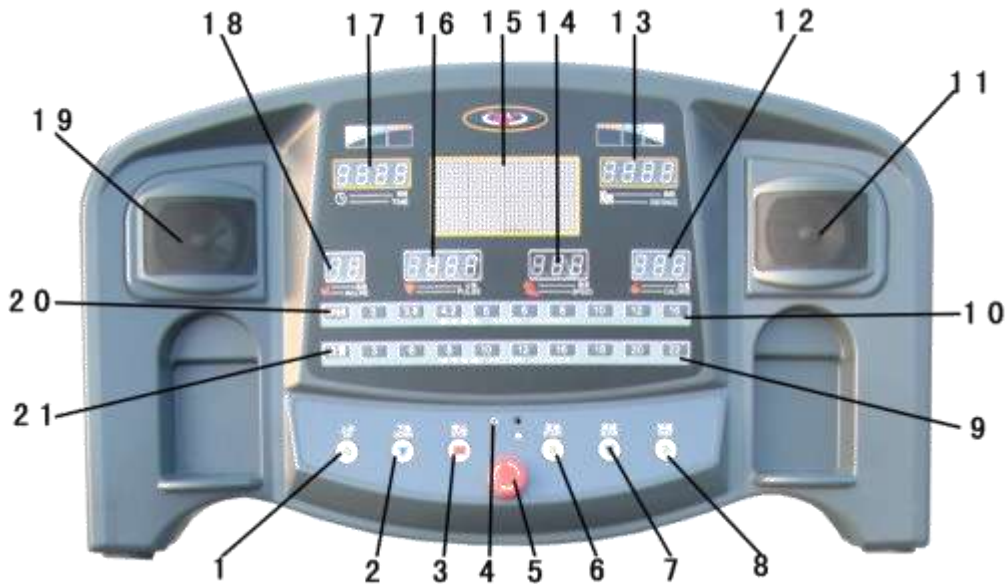

1. Incline UP button: Increase incline
2. Incline DOWN button: Decrease incline
3. STOP button: pressing it once will cause the machine to stop and retain workout information, pressing it twice will cause all kept data will become to zero.
4. Heart rate sensor jack: the sensor jack receiving the heart speed and the pulse speed
5. SAFETY KEY: stops the machine
6. START: beings workout
7. SLOW speed button: decrease speed
8. FAST speed button: increase speed
9. Easy incline choice area: Press any button in this area to jump to specific incline
10. 1Easy speed choice area: Press any button in this area to jump to specific speed
11. Speaker
12. Calorie window: Unit: K
13. Distance window: Unit: Km
14. Speed window: Unit: Km/h
15. LED lattice window: showing program that include 5 speed, 5 incline and 5 mountain

16. Pulse window
17. Time window
18. Incline window
19. Speaker
20. PROGRAM SET button: set 5 mutative speed and 5 incline.
21. Normal SET button: set speed. time, distance and pulse controlled speed.

7. USAGE GUIDE

1. Switching on the power:

Insert three-pole plug into socket and turn safety key to the right, then switch on the power. A moving caption will be displayed in the LED lattice window. At this moment the treadmill is in stop state.

2. Direct Start:

Press START button when the treadmill is in stop state. It will then run at the lowest speed. Adjust speed with speed adjustment buttons.

3. Program start:

Press the SET button when the treadmill is in stop state and all windows are displaying zero. To set data, press the SET button continuously until the desired window begins to flash then use the speed adjustment buttons to change the number. Pressing the STOP button will cancel this process. Press the START key after setting data to save the data.

4. Start using pulse controlled speed:

Press the SET button when the treadmill is in stop state and all windows are displaying zero. The target pulse will show in the pulse window. Use the speed increase or decrease buttons to change this value.

By pressing SET again, speed and distance under this menu can be set up using the speed buttons.

After finishing set up, clip the pulse sensor to left earlobe and press the START button. The treadmill will run according to the set speed and adjust itself automatically according to the user's pulse and target pulse.

Note: many factors can impact the pulse reading so pulse data should only be used for reference.

The maximum speed is 8km/h under this mode. The pulse scope under this mode is from 50 beats/min to 160 beats/min.

5. Pause and stop:

During treadmill operation, pressing the STOP once will cause it to stop and keep all data, press START button to resume workout. Pressing the STOP button twice will clear the data in all windows.

6. Total run distance:

Press the SET button five times when the treadmill is in the stop stat. Then press it again and hold it for 3 seconds the speed and distance window will show total run distance.

7. Automatic incline program:

Press the program set button to cycle the incline programs, P1, P2, P3, P4 and P5, which will be displayed in LED lattice windows. When a program is selected the machine will automatically change incline every 200M. START selects the program.

8. Quick incline selection

There are a total of 9 buttons which are located in the incline area of the display. The 9 buttons from 3-22 are quick incline selection buttons. These buttons will adjust incline automatically to chosen number.

9. Manual incline selection

The UP and DOWN buttons that are located in the lower left of the display select incline manually.

10. Quick incline selection

There are total of 9 buttons which are located in the speed area of the display. The 9 buttons from 3-16 are quick speed selection buttons. These buttons will adjust speed automatically to chosen number.

11. Automatic speed program

Press the program set button to cycle the speed programs, S1, S2, S3, S4 and S5, which will be displayed in LED lattice windows. When a program is selected the machine will automatically change speed every 200M. START selects the program.

12. Manual speed selection

The UP and DOWN buttons that are located in the lower right of the display select speed manually.

13. Automatic mountain speed program

Press the program set button to cycle programs, P1S1, P2S2, P3S3, P4S4 and P5S5, which will be displayed in LED lattice windows. When a program is selected the machine will automatically change speed every 200M. START selects the program.

8. EXERCISE GUIDE

PLEASE NOTE: Before beginning any exercise program, consult your physician. This is important especially if you are over the age of 45 or individuals with pre-existing health problems.

The pulse sensors are not medical devices. Various factors, including the user's movement, may affect the accuracy of heart rate readings. The pulse sensors are intended only as an exercise aid in determining heart rate trends in general.

Exercising is great way to control your weight, improving your fitness and reduce the effect of aging and stress. The key to success is to make exercise a regular and enjoyable part of your everyday life.

The condition of your heart and lungs and how efficient they are in delivering oxygen via your blood to your muscles is an important factor to your fitness. Your muscles use this oxygen to provide enough energy for daily activity. This is called aerobic activity. When you are fit, your heart will not have to work so hard. It will pump a lot fewer times per minute, reducing the wear and tear of your heart.

So as you can see, the fitter you are, the healthier and greater you will feel.

Warm-up

Start each workout with 5 to 10 minutes of stretching and some light exercises. A proper warm-up increases your body temperature, heart rate and circulation in preparation for exercise. Ease into your exercise.



Training Zone Exercise

After warming up, increase the intensity to your desired exercise program. Be sure to maintain your intensity for maximum performance. Breathe regularly and deeply as you exercise-never hold your breath.

Cool Down

Finish each workout with a light jog or walk for at least 1 minute. Then complete 5 to 10 minutes of stretching to cool down. This will increase the flexibility of your muscles and will help prevent post-exercise problems.

Workout Guidelines

TARGET ZONE

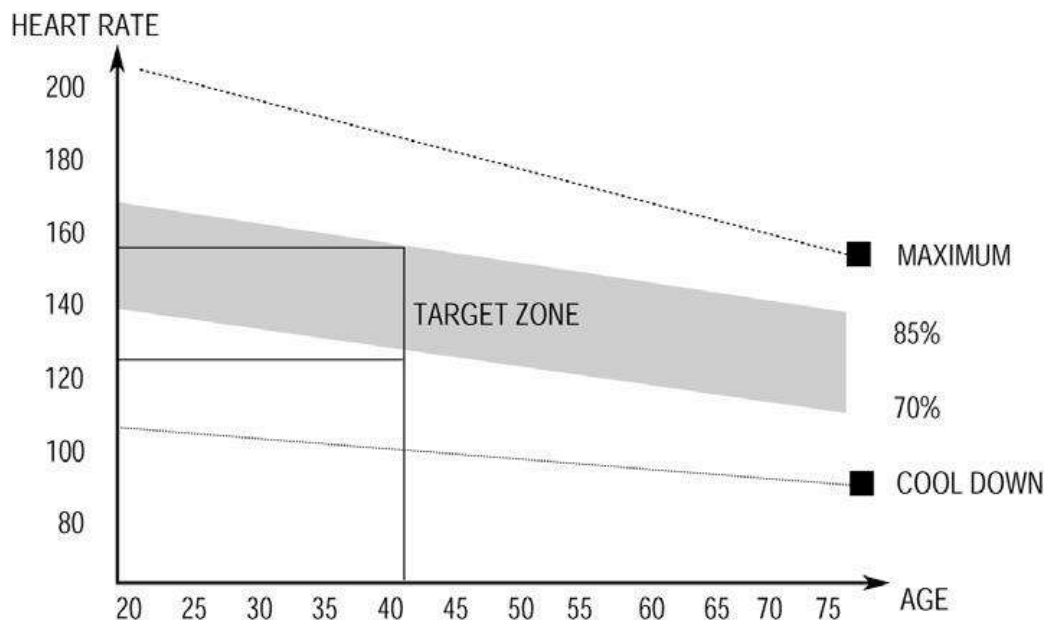

THIS IS HOW YOUR PULSE SHOULD BEHAVE DURING GENERAL FITNESS EXERCISE.

REMEMBER TO WARM UP AND COOL DOWN FOR A FEW MINUTES.

The most important factor here is the amount of effort you put in. The harder and longer you work, the more calories you will burn. Effectively this is the same as if you were training to improve your fitness, the difference is the goal.

9. MAINTENANCE INSTRUCTIONS

Reasonable cleaning/lubricating should be made to extend the life time of this unit. Performance is maximized when the belt and mat are kept as clean as possible.

WARNING: THE MAT/DECK FRICTION MAY PLAY A MAJOR ROLE IN THE FUNCTION AND LIFE OF YOUR TREADMILL AND THAT IS WHY WE RECOMMEND YOU CONSTANTLY LUBRICATE THIS FRICTION POINT TO PROLONG THE USEFUL LIFE OF YOUR TREADMILL. FAILING TO DO THIS MAY VOID YOUR WARRANTY.

WARNING: UNPLUG POWER CORD BEFORE MAINTENANCE

WARNING: STOP TREADMILL BEFORE FOLDING

1. General Cleaning

- Use a soft, damp cloth to wipe the edge of the belt and the area between the belt edge and frame. A mild soap and water solution along with a nylon scrub brush will clean the top of the textured belt. This task should be done once a month. Allow to dry before using.
- On a monthly basis, vacuum underneath your treadmill to prevent dust build up. Once a year, you should remove the black motor shield and vacuum out dirt that may accumulate.

2. General Care

- Check parts for wear before use.
- Pay particular attention to the fixing knobs and make sure they are tight.
- Always replace the mat if worn and any other defective parts.

- If in doubt do not use the treadmill and contact our helpline.

TAKE CARE TO PROTECT CARPETS AND FLOOR in case of leakages. This product is a machine that contains moving parts which have been greased / lubricated and could leak.

3. Belt/Deck/Roller Lubrication

The mat/deck friction may play a major role in the function and life of your treadmill and that is why we recommend you constantly lubricate this friction point to prolong the useful life of your treadmill. Lubrication is provided with this unit. You should apply lubrication after approximately the first 50 hours of operation. We recommend lubrication of the deck according to the following timetable:

- Light use (less than 3 hours per week) every 6 months
- Medium use (3-5 hours a week) every 3 months
- Heavy use (more than 5 hours per week) every 6-8 weeks

See below procedures for lubricating:

1. Use a soft, dry cloth to wipe the area between the belt and deck.
2. Spread lubricant onto the inside surface of belt and deck evenly (make sure the machine is turned off and power is disconnected).
3. Periodically lubricate the front and rear rollers to keep them at their peak performance. If the treadmill belt/deck/roller is kept reasonably clean it is possible to expect over 1200 hours before relubricating is necessary.

4. How to check the running mat for proper lubrication:

1. Disconnect the main power supply.
2. Fold the treadmill up into the storage position.
3. Feel the underside surface of the running mat.

If the surface is slick when touched, then no further lubrication is needed.

If the surface is dry to the touch, apply a suitable silicone lubricant.

We recommend that you use a silicone based spray to lubricate your Lifespan treadmill. This can be purchased directly from us or any hardware store.

5. Belt Tension Adjustment

It is very important for joggers and runners in order to provide a smooth, steady running surface. Adjustment must be made from the right and left rear roller in order to adjust tension with the Allen Key provided in the parts package. The adjustment bolt is located at the end of the rails as noted in the diagram below:

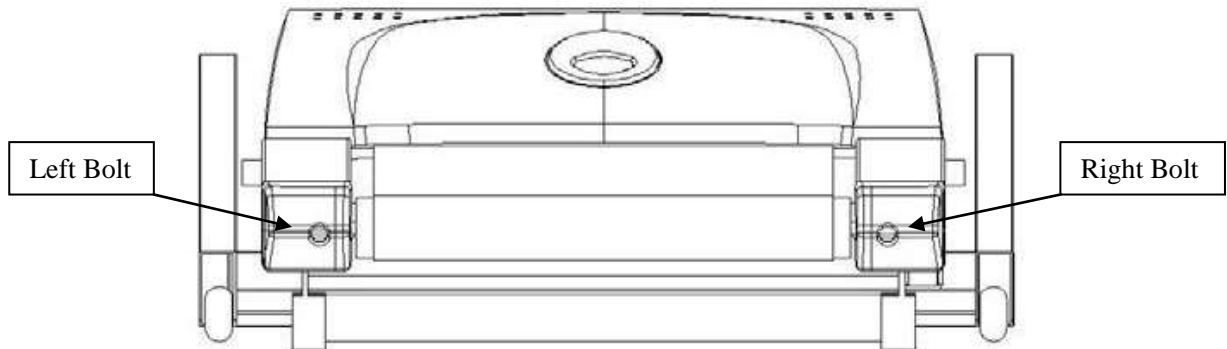

Note: Adjustment is through small hold of end cap.

Tighten the rear roller only enough to prevent slippage at the front roller. Turn both the right and left bolt clockwise one full turn and inspect for proper tension. When an adjustment is made to the belt tension, you must also make a tracking adjustment to compensate for the change in belt tension.

DO NOT OVER TIGHTEN - Over tightening will cause belt damage and premature bearing failure.

This may also cause reduced motor performance and excessive roller wear.

NOTE: When properly tightened, the sides of the belt can be raised approximately 2-3 inches off the board.

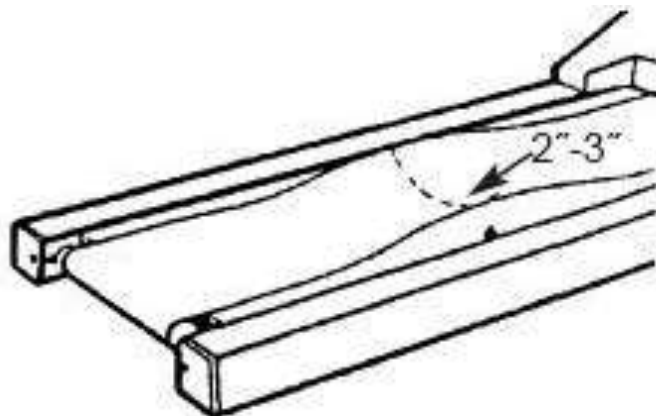

6. Belt Tracking Adjustment:

This treadmill is designed to keep the belt reasonably centred while in use. It is normal for some belts to drift near one side while the belt is running with no one on it. After a few minutes of use, the belt should have a tendency to centre itself. If during use, the belt continues to move toward one side, adjustments are necessary. The procedures are below:

1. Set speed at approximately 3.5km/h.
2. Check the side the belt shifts to.

If the belt shifts to right, tighten the right bolt and loosen the left bolt by using 6mm Allen Key, until the belt is centred itself; If belt shifts to left, tighten the left bolt and loosen the right bolt by using a 6mm Allen Key, until the belt is centred. When adjusting the belt using the 6 mm Allen Key, it is important to adjust the belt in half turn increments. Over adjusting the belt can cause damage to the mat.

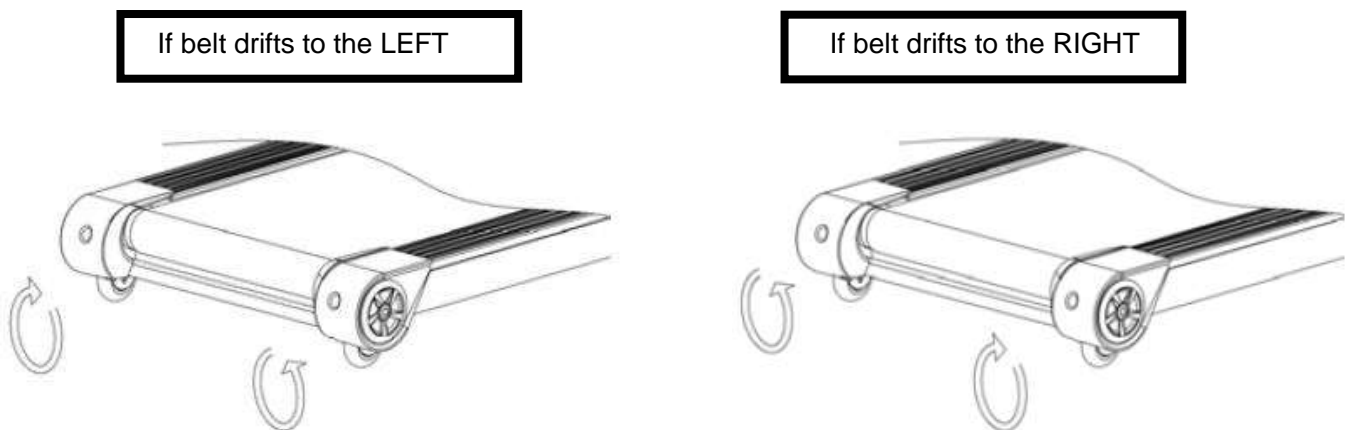

10. WARRANTY

AUSTRALIAN CONSUMER LAW

Many of our products come with a guarantee or warranty from the manufacturer. In addition, they come with guarantees that cannot be excluded under the Australian Consumer Law. You are entitled to a replacement or refund for a major failure and compensation for any other reasonably foreseeable loss or damage.

You are entitled to have the goods repaired or replaced if the goods fail to be of acceptable quality and the failure does not amount to a major failure. Full details of your consumer rights may be found at www.consumerlaw.gov.au

Please visit our website to view our full warranty terms and conditions:

<http://www.lifespanonline.com.au/Warranty-Policy>

11. PROGRAM TABLES

Numbers followed by a (%) indicate incline values

Numbers followed by a (km/h) indicate speed values

PROGRAM	INTERVAL									
	1	2	3	4	5	6	7	8	9	10
P1	0%	3%	5%	3%	4%	3%	0%	3%	5%	0%
P2	0%	3%	4%	6%	3%	5%	3%	6%	3%	0%
P3	0%	4%	0%	4%	6%	3%	0%	6%	10%	0%
P4	0%	8%	12%	0%	6%	2%	10%	8%	7%	0%
P5	0%	9%	12%	10%	7%	0%	5%	12%	6%	0%
P6	3.8km/h	4.8km/h	5km/h	5.6km/h	6km/h	5.8km/h	7km/h	5km/h	4.6km/h	3.9km/h
P7	3.8km/h	4.6km/h	5.6km/h	6km/h	7km/h	8km/h	7km/h	6km/h	5km/h	4.6km/h
P8	3.9km/h	5.2km/h	6.6km/h	8km/h	9km/h	5km/h	7km/h	6km/h	5.2km/h	4.6km/h
P9	4.2km/h	5km/h	7km/h	9km/h	12km/h	5km/h	8km/h	10km/h	5km/h	4.2km/h
P10	4.2km/h	5km/h	10km/h	5km/h	8km/h	6km/h	12km/h	5km/h	7km/h	4.6km/h
P11	0%	3%	5%	3%	4%	3%	0%	3%	5%	0%
	3.8km/h	4.8km/h	5km/h	5.6km/h	6km/h	5.8km/h	7km/h	5km/h	4.6km/h	3.9km/h
P12	0%	3%	4%	6%	3%	5%	3%	6%	3%	0%
	3.8km/h	4.6km/h	5.6km/h	6km/h	7km/h	8km/h	7km/h	6km/h	5km/h	4.6km/h
P13	0%	4%	0%	4%	6%	3%	0%	6%	10%	0%
	3.9km/h	5.2km/h	6.6km/h	8km/h	9km/h	5km/h	7km/h	6km/h	5.2km/h	4.6km/h
P14	0%	8%	12%	0%	6%	2%	10%	8%	7%	0%
	4.2km/h	5km/h	7km/h	9km/h	12km/h	5km/h	8km/h	10km/h	5km/h	4.2km/h
P15	0%	9%	12%	10%	7%	0%	5%	12%	6%	0%
	4.2km/h	5km/h	10km/h	5km/h	8km/h	6km/h	12km/h	5km/h	7km/h	4.6km/h