

TORQUE II TREADMILL OWNER'S MANUAL

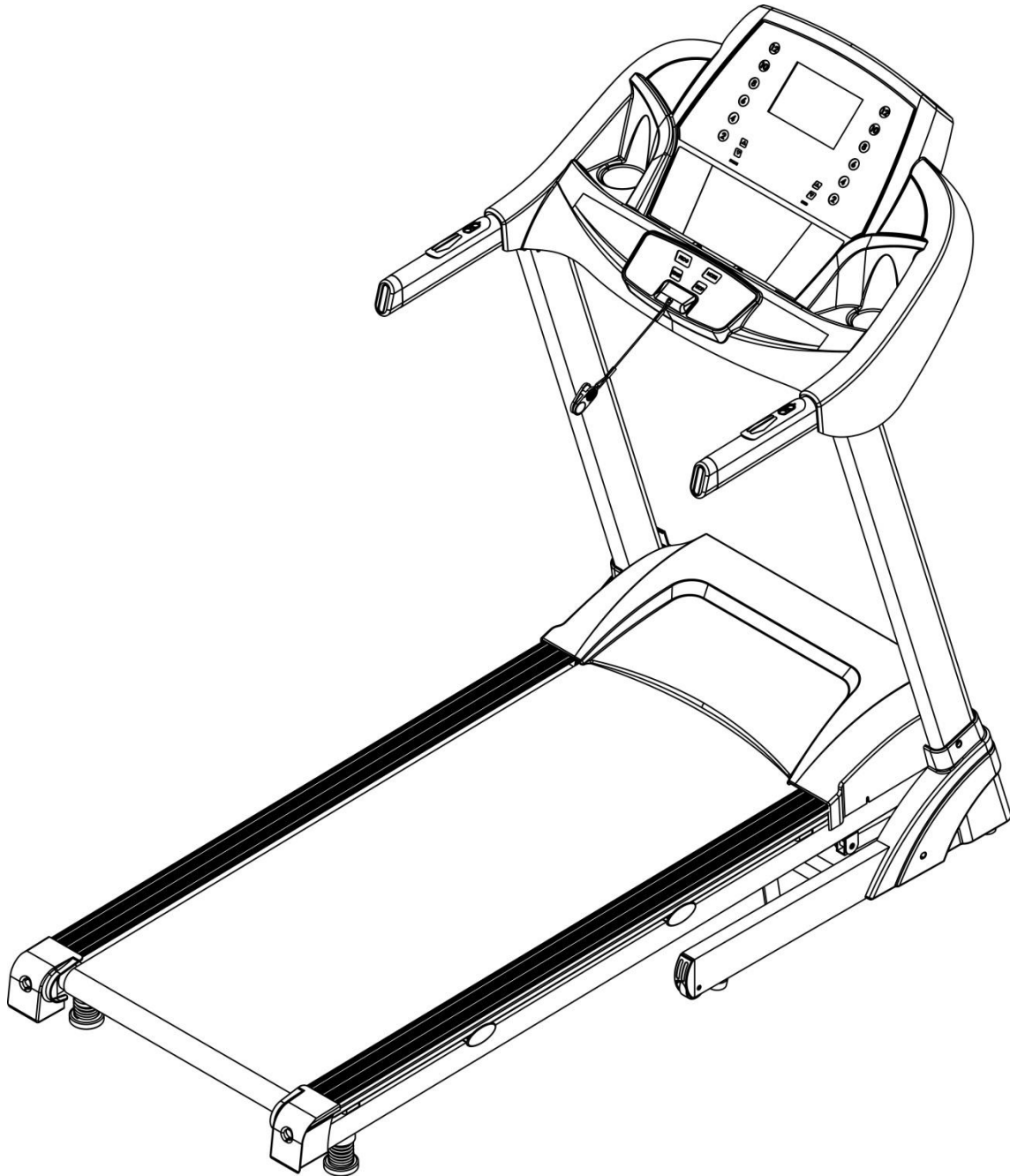

Product may vary slightly from the item pictured due to model upgrades

Read all instructions carefully before using this product. Retain this owner's manual for future reference.

TABLE OF CONTENTS

1.	IMPORTANT SAFETY INSTRUCTIONS	3
2.	IMPORTANT ELECTRICAL INFORMATION	5
3.	IMPORTANT OPERATING INSTRUCTIONS	6
4.	ASSEMBLY INSTRUCTIONS	7
5.	FOLDING INSTRUCTIONS	12
6.	OPERATION GUIDE WITH PROGRAM CHART	13
7.	EXERCISE GUIDE	23
8.	MAINTENANCE INSTRUCTIONS	25
9.	EXPLODED DIAGRAM	33
10.	PARTS LIST	34
11.	WARRANTY	36

1. IMPORTANT SAFETY INSTRUCTIONS

WARNING - Read all instructions before using this treadmill.

It is important your treadmill receives regular maintenance to prolong its useful life. Failing to regularly maintain your treadmill may void your warranty.

Danger – To reduce the risk of electric shock disconnect your treadmill from the electrical outlet prior to cleaning and/or service work.

DO NOT USE AN EXTENSION CORD: DO NOT ATTEMPT TO DISABLE THE GROUNDED PLUG BY USING IMPROPER ADAPTERS OR IN ANY WAY MODIFY THE CORD SET.

- Install the treadmill on a flat level surface with access to a 220-240 volt (50/60Hz), grounded outlet.
- Do not operate treadmill on deeply padded, plush or shag carpet. Damage to both carpet and treadmill may result.
- Do not block the rear of the treadmill. Provide a minimum of 1 metre clearance between the rear of the treadmill and any fixed object.
- Place your unit on a solid, level surface when in use
- When running, make sure the plastic clip is fastened on your clothing. It is for your safety, should you fall or move too far back on the treadmill.
- Keep hands away from all moving parts.
- Never operate the treadmill if it has a damaged power cord or plug. When damaged, these must be replaced by the manufacturer, its service agent or similarly qualified persons in order to avoid a hazard.
- Keep the cord away from heated surfaces.
- Do not operate where aerosol spray products are being used or where oxygen is being administered. Sparks from the motor may ignite a highly gaseous environment.
- Never drop or insert any object into any openings.
- The treadmill is intended for in-home use only and is not suitable for commercial environments.

- To disconnect, turn all controls to the off position, remove the safety key, and then remove the plug from the outlet.
- The pulse sensors are not medical devices. Various factors, including the user's movement, may affect the accuracy of heart rate readings. The pulse sensors are intended only as exercise aids in determining heart rate trends in general.
- Use the handrails provided; they are for your safety.
- Wear proper shoes. High heels, dress shoes, sandals or bare feet are not suitable for use on your treadmill. Quality athletic shoes are recommended to avoid leg fatigue.
- Before undertaking any type of exercise program, it is recommended that you consult a doctor.
- Injuries to health may result from incorrect or excessive training.
- This appliance is not intended for use by persons (including children) with reduced physical, sensory or mental capabilities, or lack of experience and knowledge, unless they have been given supervision or instruction concerning use of the appliance by a person responsible for their safety.
- **WARNING** heart rate monitoring systems may be inaccurate. If you feel faint stop exercising immediately.
- Children should not be allowed on or around the equipment, even when not in use.
- Children should be supervised to ensure that they do not play with this machine
- Loose-fitting clothing or jewellery that could become an entanglement hazard should not be worn.
- Training shoes should be worn when using the equipment.
- Equipment must be used on a level and stable surface.
- All fixings should be checked before the equipment is used.
- All literature relating to the use of the equipment should be retained for future reference.
- Recommended operating temperature: 5-40°C

Remove the safety key after use to prevent unauthorized treadmill operation.

2. IMPORTANT ELECTRICAL INFORMATION

WARNING!

- Route the power cord away from any moving part of the treadmill including the elevation mechanism and transport wheels.
- NEVER remove any cover without first disconnecting AC power.
- NEVER expose this treadmill to rain or moisture. This treadmill is not designed for use outdoors, near a pool, or in any other high humidity environment.
- This is a high-power item; please do not share the same outlet with other high power machines such as, fridges, air conditioning etc. Please choose an outlet exclusively for the machine and make sure the fuse is 10A.

3. IMPORTANT OPERATING INSTRUCTIONS

- Understand that changes in speed and incline do not occur immediately. Set your desired speed on the computer console and release the adjustment key. The computer will obey the command gradually.
- Use caution while participating in other activities while walking on your treadmill, such as watching television, reading, etc. These distractions may cause you to lose balance or stray from walking in the centre of the belt; which may result in serious injury.
- In order to prevent losing balance and suffering unexpected injury, never mount or dismount the treadmill while the belt is moving. This unit starts with at a very low speed. Simply standing on the belt during slow acceleration is proper after you have learned to operate this machine.
- Always hold on to handrail while making control changes.
- A safety key is provided with this machine. Remove the safety key will stop the walking belt immediately; the treadmill will shut off automatically. Inserting the safety key will reset the display.
- Do not use excessive pressure on console control keys. They are precision set to function properly with little finger pressure.
- Replace any defective components immediately. The machine must be kept out of use until repaired.
- Belt wear-in period: all treadmills make a certain type of thumping noise due to the belt riding over the rollers, especially new treadmills. This noise will diminish over time, although may not completely go away. The belt will stretch over time, causing it to ride smoother over the rollers.

4. ASSEMBLY INSTRUCTIONS

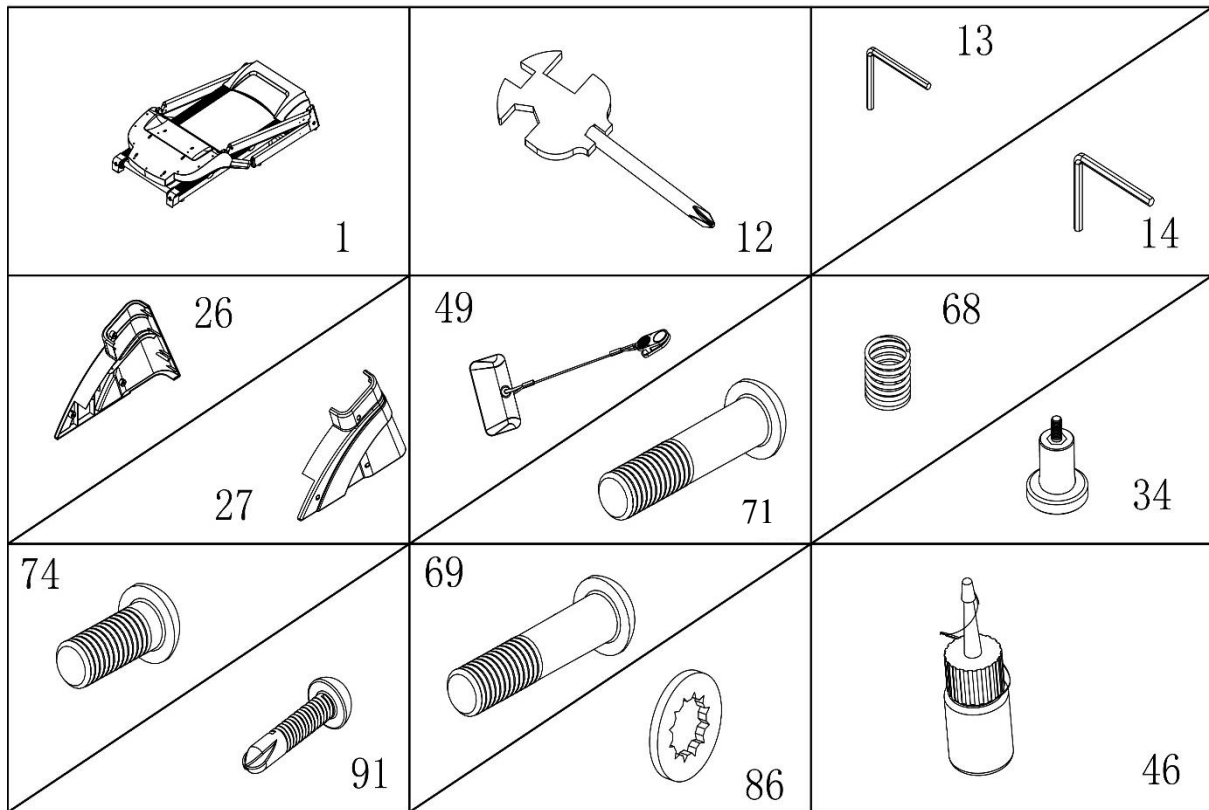

PART LIST

No	Description	Specification	Qty	No	Description	Specification	Qty
1	Main frame		1				
12	wrench w/screw driver	S=13\14\15mm	1	49	Safety key		1
13	#5 Allen wrench	5mm	1	69	Bolt	M8*45	2
14	#6 Allen wrench	6mm	1	74	Bolt	M8*16	4
27	Left back cover		1	86	Lock washer	8	8
26	Right back cover		1	91	Bolt	ST4.2*19	4
74	Bolt	M8*40	2	68	Spring		2
				34	Rubber Pad		2

FIXING TOOLS:

5# Allen Wrench 5mm 1pc

#6 Allen Wrench 6mm 1pc

Wrench s/screw Driver S=13, 14, 15 1pcs

Note: Do not get connect power before completing assembly.

STEP 1:

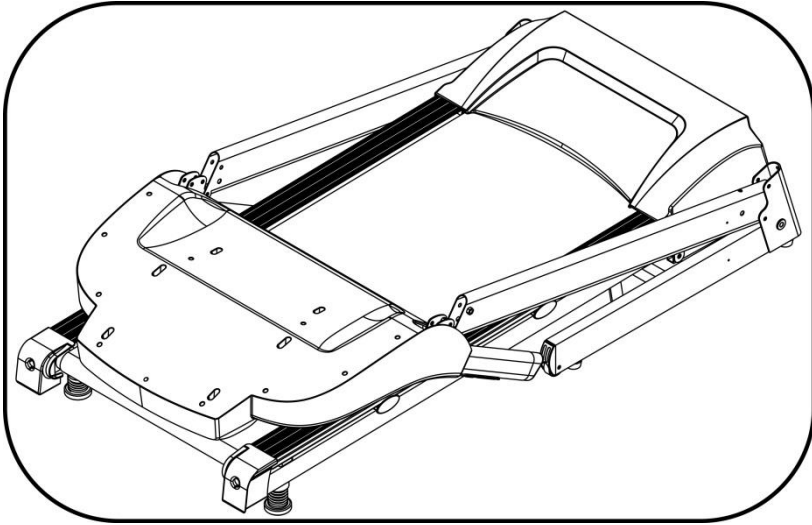

1. Open the carton
2. Extract the parts listed above
3. Place the Main Frame onto level ground

STEP 2:

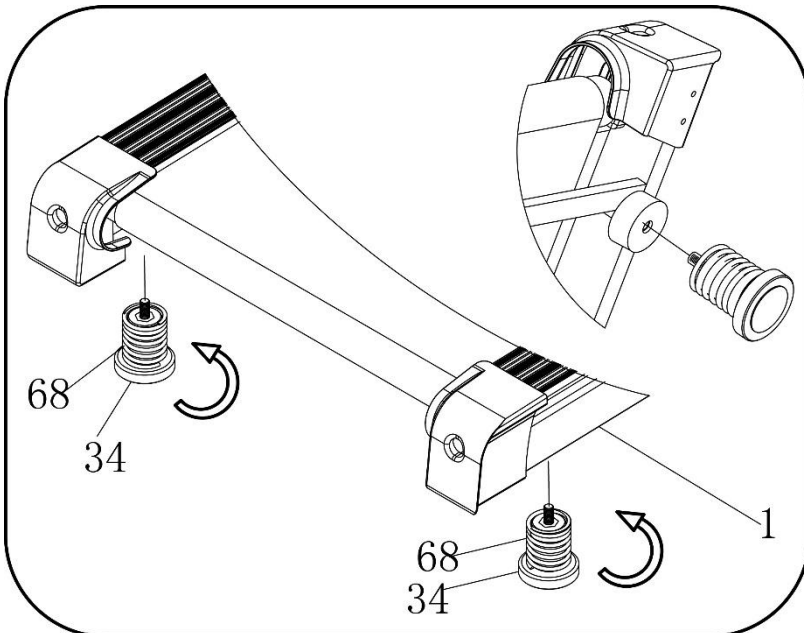

1. Remove the spring (68) and rubber pads (34) from bolt bag. Place spring (68) over rubber pads (34).
2. Screw onto main frame 1. Ensure pads are set to the same height.
3. Repeat this procedure for both sides

STEP 3:

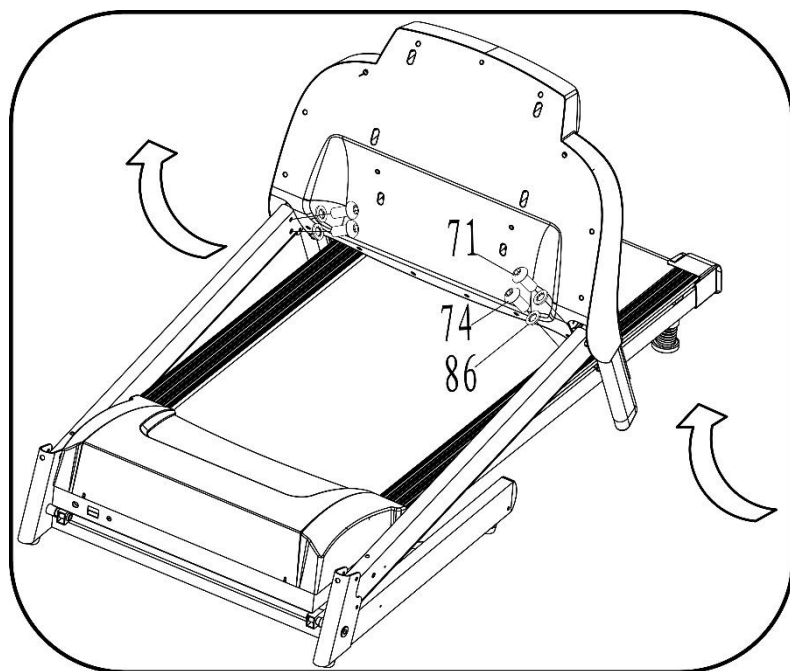

1. Position the display according to the below illustration, screw in Bolts M8*16 (74) and Lock washer (86) into the Left Upright and Right Upright.
2. Lock the Computer frame to Left Upright and Right Upright securely using Bolt M8*40 (71) and Lock washer (86).

STEP 4:

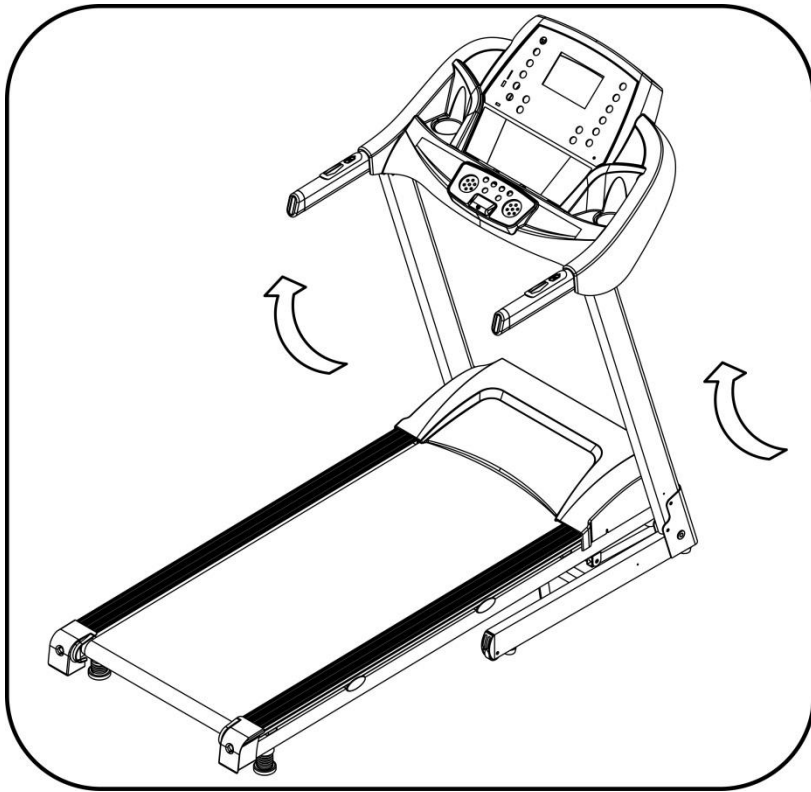

1. Do not damage the display wire when folding the display

STEP 5:

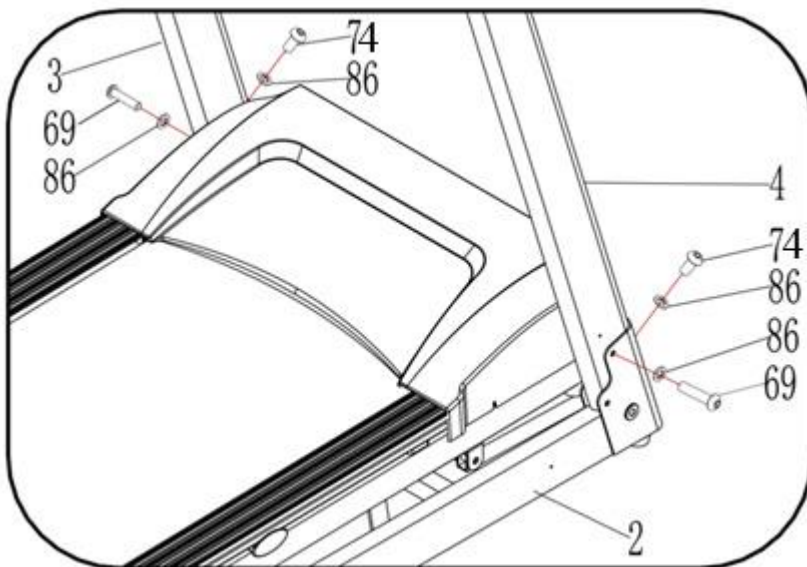

1. Using the 5# Allen wrench (13), insert the Bolt M8*45 (69) into the Lock washer (86).
2. Secure the Right Upright Tube (4) to the Main Frame. Using the 5# Allen wrench (13), insert Bolt M8*40 (74) into the Lock washer (86) to the base frame through base and right upright tube. Reference the picture left.
3. Repeat these steps for the Left Upright Tube

Note: Please support the upright with your hand to prevent it falling and causing injury.

STEP 6:

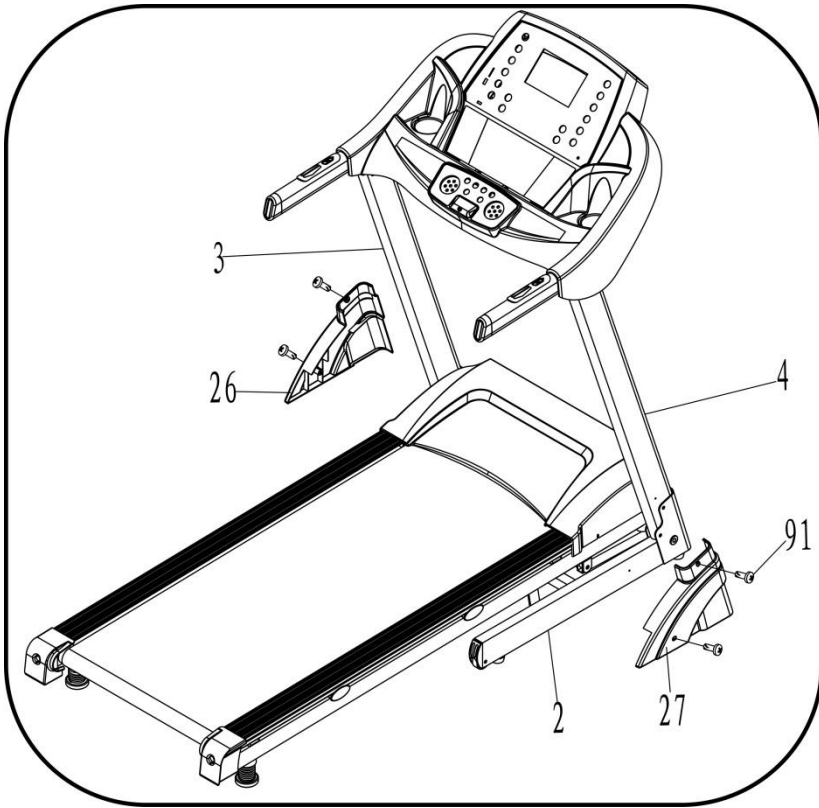

1. Use wrench w/screw driver (12) to lock the Left back cover (27) and ST4.2*19 Bolt (91) to the base frame and Left back cover.

Repeat this process for the right side

STEP 7:

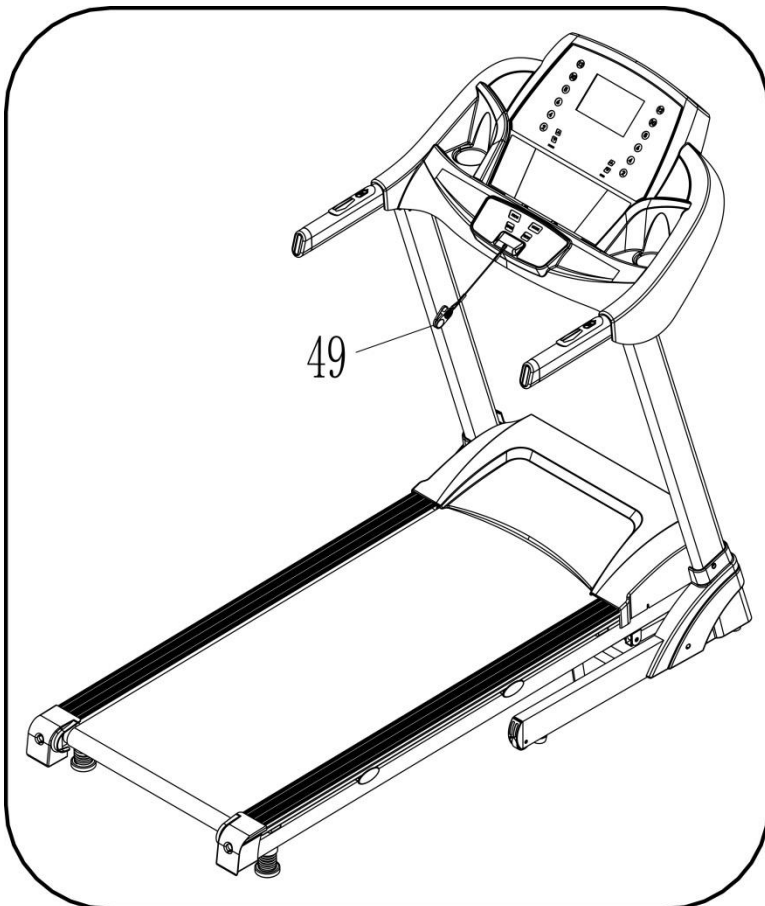

1. Place the safety key (49) onto the treadmill to start your workout

5. FOLDING INSTRUCTIONS

Folding:

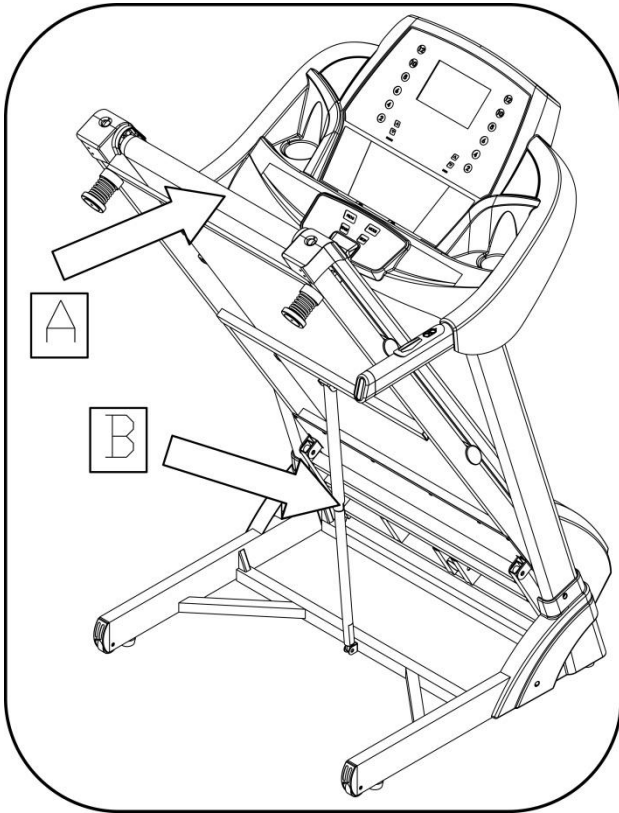

Place your hand on position (A), then pull up the base frame until you hear the click sound emitted when the air pressure bar (B) is locked into the round tube.

Unfolding:

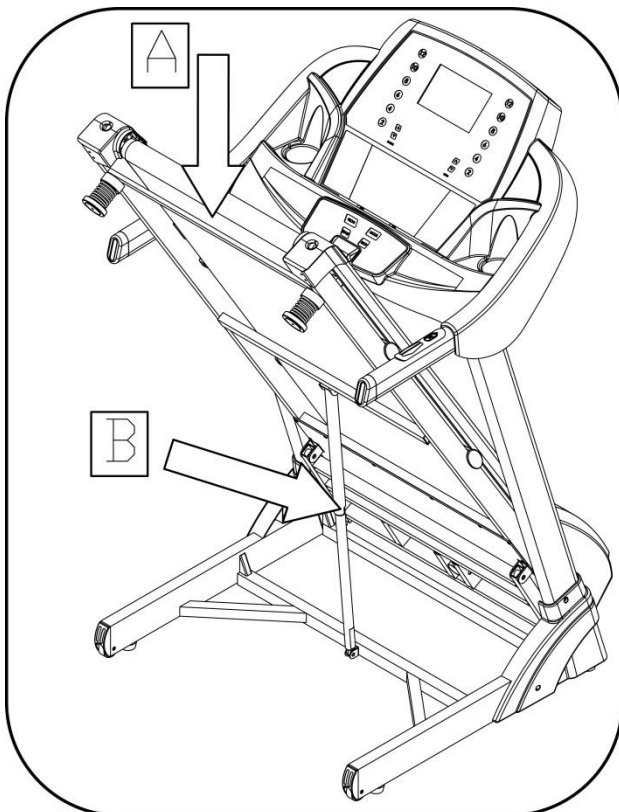

Whilst supporting position (A) with our hand, gently push position (B), the marked area on the air pressure bar, with your foot. The base frame will descend automatically. (Please keep people and any pets away the machine during descent)

Video Tutorial Available at:
<http://youtu.be/TcuPbJ7KuxQ>

Lifespan Fitness YouTube Channel:
<http://www.youtube.com/user/treadmillsvideos>

6. OPERATION GUIDE

1. OVERVIEW

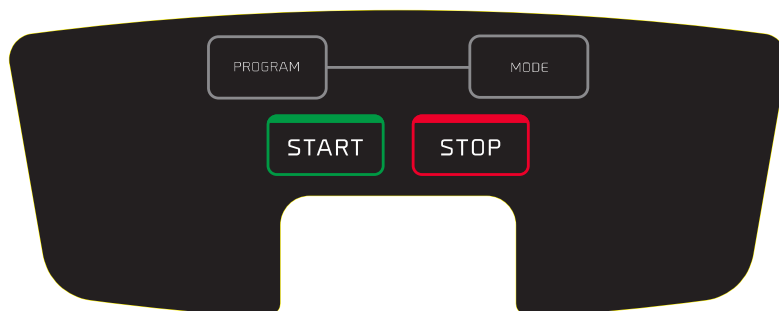

2. LCD WINDOW DISPLAY

1. **SPEED**: Shows speed and program.
2. **INCLINE**: Shows degree of incline.
3. **TIME**: displays running time
4. **DISTANCE**: shows the running distance.
5. **LAPS**: display's number of laps on a virtual 400 meter running track
6. **PULSE**: shows heart rate. (Heart rate data is for reference only)
1. **CAL**: shows calories burnt. This is an estimate only. This is not intended to be used as medical data.

3. BUTTON FUNCTIONS

1. **"PROG"**: choose the program, cycle between manual mode, P01-P02-P03 ---P99-U01-U02-U03-FAT;
2. **"MODE"**: mode selection button. Press this button to cycle the mode: mode-time count down, mode-distance count down, mode-calories count down.
3. **"START"**: begins workout. When the power is on and safety key correctly placed on the computer, press this button to start the treadmill after a 3 second countdown.
4. **"STOP"**: press button to stop the motor running and to stop the machine

Pressing the STOP once button during your workout will pause the workout and data on the LCD will remain. Press the START button to resume your workout. Instead of pressing START, you may clear the workout data by pressing the STOP button a second time.

5. **SPEED+****SPEED-**: Increase or decrease speed when exercising. Sets parameter when stopped.
6. **"INCLINE+"**, **"INCLINE-"**: increase or decreases incline. Adjust the incline gradient during exercising. Sets parameter when stopped.
7. **"SPEED: 2, 4, 6, 8, 10, 12"** Speed adjustment shortcut key
8. **"INCL: 2, 4, 6, 8, 10, 12"** Incline adjustment shortcut key.

Left handle bar buttons: adjusts incline

Right handle bar buttons: adjusts speed

4. MAIN FUNCTIONS

4.1. Quick Start-up (Manual):

Ensure the safety key is attached. After a 3 second countdown, the treadmill will starting and running from the lowest speed, add and subtract to the speed using the SPEED +/- button.

4.2. Countdown mode:

Press the MODE button to cycle options: timer countdown, distance countdown, calories countdown. The default value corresponds to the window and flashing display. At this point the SPEED buttons serve as a plus and minus functions to adjust to the desired value. Press the START, add and subtract speed by using SPEED buttons once again. When the countdown reaches 0, the machine will stop. You can also directly press the STOP button or disconnect safety lock to stop.

4.3. Preset programs:

Press the program button; programs from P1 to P99 are built-in programs. The time window displays the default value of TIME. When flashing, press the SPEED buttons to adjust to your desired time. Built-in program are divided into 10 equal segments. After pressing the START button, the treadmill will automatically cycle through the time segments. Speed will automatically adjust to the preset value for the segment. Upon completion of the segments, the program will end, slowing the treadmill down to a stop. During the operation speed can be adjusted but the next segment will be automatically adjusted to the program defaults. Built-in program data is listed on the table.

Program Chart

TIME PROG		Total program time / 20 = running time of each segment																			
		1	2	3	4	5	6	7	8	9	10	11	12	13	14	15	16	17	18	19	20
P01	SPEED	2	3	3	4	5	3	4	5	5	3	4	5	4	4	4	2	3	3	5	3
	INCLINE	1	1	2	2	2	3	3	3	2	2	1	2	2	1	1	3	3	2	2	2
P02	SPEED	2	4	4	5	6	4	6	6	6	4	5	6	4	4	4	2	2	5	4	2
	INCLINE	1	2	2	2	2	3	3	2	2	2	2	2	3	3	3	4	4	3	2	2
P03	SPEED	2	4	4	6	6	4	7	7	7	4	7	7	4	4	4	2	4	5	3	2
	INCLINE	2	3	3	2	2	3	3	3	2	2	2	2	4	4	4	6	6	3	2	2
P04	SPEED	3	5	5	6	7	7	5	7	7	8	8	5	9	5	5	6	6	4	4	3
	INCLINE	2	3	3	2	2	3	3	3	2	2	2	2	4	4	4	6	6	3	2	2
P05	SPEED	2	4	4	5	6	7	7	5	6	7	8	8	5	4	3	3	6	5	4	2
	INCLINE	3	3	3	4	4	5	5	5	4	4	4	4	5	5	3	3	3	2	2	2
P06	SPEED	2	4	4	4	5	6	8	8	6	7	8	8	6	4	4	2	5	4	3	2
	INCLINE	3	5	5	5	4	4	4	3	3	3	3	4	4	4	3	3	3	4	3	2
P07	SPEED	2	3	3	3	4	5	3	4	5	3	4	5	3	3	3	6	6	5	3	3
	INCLINE	4	4	4	4	3	3	6	6	6	7	7	8	8	9	9	6	6	5	4	4
P08	SPEED	2	3	3	6	7	7	4	6	7	4	6	7	4	4	4	2	3	4	4	2
	INCLINE	4	5	5	5	6	6	6	7	8	9	9	9	10	10	10	12	12	8	6	3
P09	SPEED	2	4	4	7	7	4	7	8	4	8	9	9	4	4	4	5	6	3	3	2
	INCLINE	5	5	5	6	6	6	4	4	6	6	5	5	8	8	9	9	9	7	4	2
P10	SPEED	2	4	5	6	7	5	4	6	8	8	6	6	5	4	4	2	4	4	3	3
	INCLINE	5	6	6	6	7	5	8	8	4	4	4	5	5	8	8	10	10	8	6	3
P11	SPEED	2	5	8	10	7	7	10	10	7	7	10	10	5	5	9	9	5	5	4	3
	INCLINE	4	5	3	2	6	6	2	2	2	2	2	4	5	6	3	2	5	5	2	0
P12	SPEED	3	4	9	9	5	9	5	8	5	9	7	5	5	7	9	9	5	7	6	3
	INCLINE	1	2	3	2	3	5	5	0	0	2	3	5	7	3	3	5	6	5	3	3
P13	SPEED	3	6	7	5	9	9	7	5	5	7	9	5	8	5	9	5	9	9	4	3
	INCLINE	3	3	5	6	5	3	3	7	5	3	2	0	0	5	5	3	2	3	2	1
P14	SPEED	2	2	4	5	6	5	4	3	2	1	2	3	4	5	6	5	4	3	2	1
	INCLINE	4	4	4	4	3	3	6	6	6	7	7	8	8	9	9	6	6	5	4	4
P15	SPEED	2	4	6	8	6	6	4	4	2	2	2	4	6	8	6	6	4	4	2	2
	INCLINE	3	3	3	4	4	5	5	5	4	4	4	4	5	5	3	3	3	2	2	2
P16	SPEED	2	4	6	8	10	8	6	4	2	2	2	4	6	8	6	6	4	4	2	2
	INCLINE	5	5	5	6	6	6	4	4	6	6	5	5	8	8	9	9	9	7	4	1
P17	SPEED	2	2	6	6	8	10	6	6	2	2	2	2	6	6	8	10	6	6	2	2
	INCLINE	4	5	5	5	6	6	6	7	8	9	9	9	10	10	10	12	12	8	6	3
P18	SPEED	2	3	4	5	2	3	4	5	3	2	2	3	4	5	2	3	4	5	3	2
	INCLINE	4	4	4	4	3	3	6	6	6	7	7	8	8	9	9	6	6	5	3	2
P19	SPEED	2	4	6	2	4	6	2	4	6	2	2	4	6	2	4	6	2	4	6	2
	INCLINE	3	5	5	5	4	4	4	3	3	3	3	4	4	4	3	3	3	4	3	2
P20	SPEED	1	3	4	5	6	5	4	3	2	1	1	3	4	5	6	5	4	3	2	1
	INCLINE	3	3	3	4	4	5	5	5	4	4	4	4	5	5	3	3	3	2	2	2
P21	SPEED	2	3	3	4	5	3	4	5	5	3	4	5	4	4	4	2	3	3	5	3
	INCLINE	1	1	2	2	2	3	3	3	2	2	1	2	2	1	1	3	3	2	2	2
P22	SPEED	2	4	4	5	6	4	6	6	6	4	5	6	4	4	4	2	2	5	4	2
	INCLINE	1	2	2	2	2	3	3	2	2	2	2	2	3	3	3	4	4	3	2	2
P23	SPEED	2	4	4	6	6	4	7	7	7	4	7	7	4	4	4	2	4	5	3	2

	INCLINE	2	3	3	2	2	3	3	3	2	2	2	2	4	4	4	6	6	3	2	2
P24	SPEED	3	5	5	6	7	7	5	7	7	8	8	5	9	5	5	6	6	4	4	3
	INCLINE	2	3	3	2	2	3	3	3	2	2	2	2	4	4	4	6	6	3	2	2
P25	SPEED	2	4	4	5	6	7	7	5	6	7	8	8	5	4	3	3	6	5	4	2
	INCLINE	3	3	3	4	4	5	5	5	4	4	4	4	5	5	3	3	3	2	2	2
P26	SPEED	2	4	4	4	5	6	8	8	6	7	8	8	6	4	4	2	5	4	3	2
	INCLINE	3	5	5	5	4	4	4	3	3	3	3	4	4	4	3	3	3	4	3	2
P27	SPEED	2	3	3	3	4	5	3	4	5	3	4	5	3	3	3	6	6	5	3	3
	INCLINE	4	4	4	4	3	3	6	6	6	7	7	8	8	9	9	6	6	5	3	3
P28	SPEED	2	3	3	6	7	7	4	6	7	4	6	7	4	4	4	2	3	4	4	2
	INCLINE	4	5	5	5	6	6	6	7	8	9	9	9	10	10	10	12	12	8	6	3
P29	SPEED	2	4	4	7	7	4	7	8	4	8	9	9	4	4	4	5	6	3	3	2
	INCLINE	5	5	5	6	6	6	4	4	6	6	5	5	8	8	9	9	9	7	4	2
P30	SPEED	2	4	5	6	7	5	4	6	8	8	6	6	5	4	4	2	4	4	3	3
	INCLINE	5	6	6	6	7	5	8	8	4	4	4	5	5	8	8	10	10	8	6	3
P31	SPEED	2	5	8	10	7	7	10	10	7	7	10	10	6	6	9	9	5	5	4	3
	INCLINE	4	5	3	2	6	6	2	2	2	2	2	4	5	6	3	2	5	5	2	0
P32	SPEED	3	4	9	9	5	9	5	8	5	9	7	5	5	7	9	9	5	7	6	3
	INCLINE	1	2	3	2	3	5	5	0	0	2	3	5	7	3	3	5	6	5	3	3
P33	SPEED	3	4	9	9	5	9	5	8	5	9	7	5	5	7	9	9	5	7	6	3
	INCLINE	1	2	3	2	3	5	5	0	0	2	3	5	7	3	3	5	6	5	3	3
P34	SPEED	2	2	4	5	6	5	4	3	2	1	2	3	4	5	6	5	4	3	2	1
	INCLINE	1	1	1	1	1	1	1	1	1	1	1	1	1	1	1	1	1	1	1	1
P35	SPEED	2	4	6	8	6	6	4	4	2	2	2	4	6	8	6	6	4	4	2	2
	INCLINE	1	1	1	1	1	1	1	1	1	1	1	1	1	1	1	1	1	1	1	1
P36	SPEED	2	4	6	8	10	8	6	4	2	2	2	4	6	8	6	6	4	4	2	2
	INCLINE	5	5	5	6	6	6	4	4	6	6	5	5	8	8	9	9	9	7	4	2
P37	SPEED	2	2	6	6	8	10	6	6	2	2	2	2	6	6	8	10	6	6	2	2
	INCLINE	4	5	5	5	6	6	6	7	8	9	9	9	10	10	10	12	12	8	6	3
P38	SPEED	2	3	4	5	2	3	4	5	3	2	2	3	4	5	2	3	4	5	3	2
	INCLINE	4	4	4	4	3	3	6	6	6	7	7	8	8	9	9	6	6	5	3	3
P39	SPEED	2	4	6	2	4	6	2	4	6	2	2	4	6	2	4	6	2	4	6	2
	INCLINE	3	5	5	5	4	4	4	3	3	3	3	4	4	4	3	3	3	4	3	2
P40	SPEED	1	3	4	5	6	5	4	3	2	1	1	3	4	5	6	5	4	3	2	1
	INCLINE	3	3	3	4	4	5	5	5	4	4	4	4	5	5	3	3	3	2	2	2
P41	SPEED	2	3	3	4	5	3	4	5	5	3	4	5	4	4	4	2	3	3	5	3
	INCLINE	1	1	2	2	2	3	3	3	2	2	1	2	2	1	1	3	3	2	2	2
P42	SPEED	2	4	4	5	6	4	6	6	6	4	5	6	4	4	4	2	2	5	4	2
	INCLINE	1	2	2	2	2	3	3	2	2	2	2	2	3	3	3	4	4	3	2	2
P43	SPEED	2	4	4	6	6	4	7	7	7	4	7	7	4	4	4	2	4	5	3	2
	INCLINE	2	3	3	2	2	3	3	3	2	2	2	2	4	4	4	6	6	3	2	2
P44	SPEED	3	5	5	6	7	7	5	7	7	8	8	5	9	5	5	6	6	4	4	3
	INCLINE	2	3	3	2	2	3	3	3	2	2	2	2	4	4	4	6	6	3	2	2
P45	SPEED	2	4	4	5	6	7	7	5	6	7	8	8	5	4	3	3	6	5	4	2
	INCLINE	3	3	3	4	4	5	5	5	4	4	4	4	5	5	3	3	3	2	2	2
P46	SPEED	2	4	4	4	5	6	8	8	6	7	8	8	6	4	4	2	5	4	3	2
	INCLINE	3	5	5	5	4	4	4	3	3	3	3	4	4	4	3	3	3	4	3	2
P47	SPEED	2	3	3	3	4	5	3	4	5	3	4	5	3	3	3	6	6	5	3	3
	INCLINE	4	4	4	4	3	3	6	6	6	7	7	8	8	9	9	6	6	5	3	3

P48	SPEED	2	3	3	6	7	7	4	6	7	4	6	7	4	4	4	2	3	4	4	2
	INCLINE	4	5	5	5	6	6	6	7	8	9	9	9	10	10	10	12	12	8	6	3
P49	SPEED	2	4	4	7	7	4	7	8	4	8	9	9	4	4	4	5	6	3	3	2
	INCLINE	5	5	5	6	6	6	4	4	6	6	5	5	8	8	9	9	9	7	4	2
P50	SPEED	2	4	5	6	7	5	4	6	8	8	6	6	5	4	4	2	4	4	3	3
	INCLINE	5	6	6	6	7	5	8	8	4	4	4	5	5	8	8	10	10	8	6	3
P51	SPEED	2	5	8	10	7	7	10	10	7	7	10	10	6	6	9	9	5	5	4	3
	INCLINE	4	5	3	2	6	6	2	2	2	2	2	4	5	6	3	2	5	5	2	0
P52	SPEED	3	4	9	9	5	9	5	8	5	9	7	5	5	7	9	9	5	7	6	3
	INCLINE	1	2	3	2	3	5	5	0	0	2	3	5	7	3	3	5	6	5	3	3
P53	SPEED	3	4	9	9	5	9	5	8	5	9	7	5	5	7	9	9	5	7	6	3
	INCLINE	1	2	3	2	3	5	5	0	0	2	3	5	7	3	3	5	6	5	3	3
P54	SPEED	2	2	4	5	6	5	4	3	2	1	2	3	4	5	6	5	4	3	2	1
	INCLINE	1	1	1	1	1	1	1	1	1	1	1	1	1	1	1	1	1	1	1	1
P55	SPEED	2	4	6	8	6	6	4	4	2	2	2	4	6	8	6	6	4	4	2	2
	INCLINE	1	1	1	1	1	1	1	1	1	1	1	1	1	1	1	1	1	1	1	1
P56	SPEED	2	4	6	8	10	8	6	4	2	2	2	4	6	8	6	6	4	4	2	2
	INCLINE	5	5	5	6	6	6	4	4	6	6	5	5	8	8	9	9	9	7	4	2
P57	SPEED	2	2	6	6	8	10	6	6	2	2	2	2	6	6	8	10	6	6	2	2
	INCLINE	4	5	5	5	6	6	6	7	8	9	9	9	10	10	10	12	12	8	6	3
P58	SPEED	2	3	4	5	2	3	4	5	3	2	2	3	4	5	2	3	4	5	3	2
	INCLINE	4	4	4	4	3	3	6	6	6	7	7	8	8	9	9	6	6	5	3	3
P59	SPEED	2	4	6	2	4	6	2	4	6	2	2	4	6	2	4	6	2	4	6	2
	INCLINE	3	5	5	5	4	4	4	3	3	3	3	4	4	4	3	3	3	4	3	2
P60	SPEED	1	3	4	5	6	5	4	3	2	1	1	3	4	5	6	5	4	3	2	1
	INCLINE	3	3	3	4	4	5	5	5	4	4	4	4	5	5	3	3	3	2	2	2
P61	SPEED	2	3	3	4	5	3	4	5	5	3	4	5	4	4	4	2	3	3	5	3
	INCLINE	1	1	2	2	2	3	3	3	2	2	1	2	2	1	1	3	3	2	2	2
P62	SPEED	2	4	4	5	6	4	6	6	6	4	5	6	4	4	4	2	2	5	4	2
	INCLINE	1	2	2	2	2	3	3	2	2	2	2	2	3	3	3	4	4	3	2	2
P63	SPEED	2	4	4	6	6	4	7	7	7	4	7	7	4	4	4	2	4	5	3	2
	INCLINE	2	3	3	2	2	3	3	3	2	2	2	2	4	4	4	6	6	3	2	2
P64	SPEED	3	5	5	6	7	7	5	7	7	8	8	5	9	5	5	6	6	4	4	3
	INCLINE	2	3	3	2	2	3	3	3	2	2	2	2	4	4	4	6	6	3	2	2
P65	SPEED	2	4	4	5	6	7	7	5	6	7	8	8	5	4	3	3	6	5	4	2
	INCLINE	3	3	3	4	4	5	5	5	4	4	4	4	5	5	3	3	3	2	2	2
P66	SPEED	2	4	4	4	5	6	8	8	6	7	8	8	6	4	4	2	5	4	3	2
	INCLINE	3	5	5	5	4	4	4	3	3	3	3	4	4	4	3	3	3	4	3	2
P67	SPEED	2	3	3	3	4	5	3	4	5	3	4	5	3	3	3	6	6	5	3	3
	INCLINE	4	4	4	4	3	3	6	6	6	7	7	8	8	9	9	6	6	5	3	3
P68	SPEED	2	3	3	6	7	7	4	6	7	4	6	7	4	4	4	2	3	4	4	2
	INCLINE	4	5	5	5	6	6	6	7	8	9	9	9	10	10	10	12	12	8	6	3
P69	SPEED	2	4	4	7	7	4	7	8	4	8	9	9	4	4	4	5	6	3	3	2
	INCLINE	5	5	5	6	6	6	4	4	6	6	5	5	8	8	9	9	9	7	4	2
P70	SPEED	2	4	5	6	7	5	4	6	8	8	6	6	5	4	4	2	4	4	3	3
	INCLINE	5	6	6	6	7	5	8	8	4	4	4	5	5	8	8	10	10	8	6	3
P71	SPEED	2	5	8	10	7	7	10	10	7	7	10	10	6	6	9	9	5	5	4	3
	INCLINE	4	5	3	2	6	6	2	2	2	2	2	2	4	5	6	3	2	5	5	2
P72	SPEED	3	4	9	9	5	9	5	8	5	9	7	5	5	7	9	9	5	7	6	3

	INCLINE	1	2	3	2	3	5	5	0	0	2	3	5	7	3	3	5	6	5	3	3
P73	SPEED	3	4	9	9	5	9	5	8	5	9	7	5	5	7	9	9	5	7	6	3
	INCLINE	1	2	3	2	3	5	5	0	0	2	3	5	7	3	3	5	6	5	3	3
P74	SPEED	2	2	4	5	6	5	4	3	2	1	2	3	4	5	6	5	4	3	2	1
	INCLINE	1	1	1	1	1	1	1	1	1	1	1	1	1	1	1	1	1	1	1	1
P75	SPEED	2	4	6	8	6	6	4	4	2	2	2	4	6	8	6	6	4	4	2	2
	INCLINE	1	1	1	1	1	1	1	1	1	1	1	1	1	1	1	1	1	1	1	1
P76	SPEED	2	4	6	8	10	8	6	4	2	2	2	4	6	8	6	6	4	4	2	2
	INCLINE	5	5	5	6	6	6	4	4	6	6	5	5	8	8	9	9	9	7	4	2
P77	SPEED	2	2	6	6	8	10	6	6	2	2	2	2	6	6	8	10	6	6	2	2
	INCLINE	4	5	5	5	6	6	6	7	8	9	9	9	10	10	10	12	12	8	6	3
P78	SPEED	2	3	4	5	2	3	4	5	3	2	2	3	4	5	2	3	4	5	3	2
	INCLINE	4	4	4	4	3	3	6	6	6	7	7	8	8	9	9	6	6	5	3	3
P79	SPEED	2	4	6	2	4	6	2	4	6	2	2	4	6	2	4	6	2	4	6	2
	INCLINE	3	5	5	5	4	4	4	3	3	3	3	4	4	4	3	3	3	4	3	2
P80	SPEED	1	3	4	5	6	5	4	3	2	1	1	3	4	5	6	5	4	3	2	1
	INCLINE	3	3	3	4	4	5	5	5	4	4	4	4	5	5	3	3	3	2	2	2
P81	SPEED	2	3	3	4	5	3	4	5	5	3	4	5	4	4	4	2	3	3	5	3
	INCLINE	1	1	2	2	2	3	3	3	2	2	1	2	2	1	1	3	3	2	2	2
P82	SPEED	2	4	4	5	6	4	6	6	6	4	5	6	4	4	4	2	2	5	4	2
	INCLINE	1	2	2	2	2	3	3	2	2	2	2	2	3	3	3	4	4	3	2	2
P83	SPEED	2	4	4	6	6	4	7	7	7	4	7	7	4	4	4	2	4	5	3	2
	INCLINE	2	3	3	2	2	3	3	3	2	2	2	2	4	4	4	6	6	3	2	2
P84	SPEED	3	5	5	6	7	7	5	7	7	8	8	5	9	5	5	6	6	4	4	3
	INCLINE	2	3	3	2	2	3	3	3	2	2	2	2	4	4	4	6	6	3	2	2
P85	SPEED	2	4	4	5	6	7	7	5	6	7	8	8	5	4	3	3	6	5	4	2
	INCLINE	3	3	3	4	4	5	5	5	4	4	4	4	5	5	3	3	3	2	2	2
P86	SPEED	2	4	4	4	5	6	8	8	6	7	8	8	6	4	4	2	5	4	3	2
	INCLINE	3	5	5	5	4	4	4	3	3	3	3	4	4	4	3	3	3	4	3	2
P87	SPEED	2	3	3	3	4	5	3	4	5	3	4	5	3	3	3	6	6	5	3	3
	INCLINE	4	4	4	4	3	3	6	6	6	7	7	8	8	9	9	6	6	5	3	3
P88	SPEED	2	3	3	6	7	7	4	6	7	4	6	7	4	4	4	2	3	4	4	2
	INCLINE	4	5	5	5	6	6	6	7	8	9	9	9	10	10	10	12	12	8	6	3
P89	SPEED	2	4	4	7	7	4	7	8	4	8	9	9	4	4	4	5	6	3	3	2
	INCLINE	5	5	5	6	6	6	4	4	6	6	5	5	8	8	9	9	9	7	4	2
P90	SPEED	2	4	5	6	7	5	4	6	8	8	6	6	5	4	4	2	4	4	3	3
	INCLINE	5	6	6	6	7	5	8	8	4	4	4	5	5	8	8	10	10	8	6	3
P91	SPEED	2	5	8	10	7	7	10	10	7	7	10	10	6	6	9	9	5	5	4	3
	INCLINE	4	5	3	2	6	6	2	2	2	2	2	2	4	5	6	3	2	5	5	2
P92	SPEED	3	4	9	9	5	9	5	8	5	9	7	5	5	7	9	9	5	7	6	3
	INCLINE	1	2	3	2	3	5	5	0	0	2	3	5	7	3	3	5	6	5	3	3
P93	SPEED	3	4	9	9	5	9	5	8	5	9	7	5	5	7	9	9	5	7	6	3
	INCLINE	1	2	3	2	3	5	5	0	0	2	3	5	7	3	3	5	6	5	3	3
P94	SPEED	2	2	4	5	6	5	4	3	2	1	2	3	4	5	6	5	4	3	2	1
	INCLINE	1	1	1	1	1	1	1	1	1	1	1	1	1	1	1	1	1	1	1	1
P95	SPEED	2	4	6	8	6	6	4	4	2	2	2	4	6	8	6	6	4	4	2	2
	INCLINE	1	1	1	1	1	1	1	1	1	1	1	1	1	1	1	1	1	1	1	1
P96	SPEED	2	4	6	8	10	8	6	4	2	2	2	4	6	8	6	6	4	4	2	2
	INCLINE	5	5	5	6	6	6	4	4	6	6	5	5	8	8	9	9	9	7	4	2

P97	SPEED	2	2	6	6	8	10	6	6	2	2	2	2	6	6	8	10	6	6	2	2
	INCLINE	4	5	5	5	6	6	6	7	8	9	9	9	10	10	10	12	12	8	6	3
P98	SPEED	2	3	4	5	2	3	4	5	3	2	2	3	4	5	2	3	4	5	3	2
	INCLINE	4	4	4	4	3	3	6	6	6	7	7	8	8	9	9	6	6	5	3	3
P99	SPEED	2	4	6	2	4	6	2	4	6	2	2	4	6	2	4	6	2	4	6	2
	INCLINE	3	5	5	5	4	4	4	3	3	3	3	4	4	4	3	3	3	4	3	2

4.4. Heart Rate:

When holding the hand pulse with two hands, the pulse window will show your heart rate after 5 seconds.

To increase accuracy please check heart rate with the machine stopped and after keeping your hands on the sensors for more than 30 seconds.

The heart rate data is for reference purposes ONLY and should not be used for medical purposes.

4.5. Sleep function:

The treadmill automatically enters sleep mode after 10 minutes of inactivity. Press any key on the display to wake the treadmill.

4.6. Data display and set range:

	RANGE	DEFAULT MODE	DEFAULT PROGRAM	SET RANGE
Time (min:sec)	0:00	15:00	5:00-99:00	0:00—99:59
Incline (levels)	0	0	0-20	0-20
Speed (km/h)	1.0	1.0	1.0-18	1.0-18
Distance(km)	0	1.00	0.50-99.9	0.00—99.9
Pulse (beats/min)	P	N/A	N/A	50-200
Calories (kilocalories)	0	50.0	10.0-999	0—999

4.7. User Defined Programs

There are three user defined programs U1, U2, U3

1. User defined program set up

Press “PROGRAM” continuously in standby mode until window displays U1-U3. Press “MODE” to start setting first segment, setup speed and incline by pressing “SPEED+” “SPEED-” AND “INCLINE+”

“INCLINE-”. Press “MODE” to finish first segment setting and to begin segment. Repeat this until all 10

segments have been completed. The data will be permanently saved until it is overwritten via this process.

2. Starting the user defined program

- a. Press the “PROG” button whilst in standby mode until the window displays U01-U03, press START after setting the running desired running time for this program.
- b. Alternatively you may press the START button immediately after you have finishing setting up the user define program

3. Instruction of user define program setting

Each program is divided into 10 segments. The machine can only be started when all the speed and incline are finish set for each segment.

4.8. Body Fat Test Function

1. Press the “PROGRAM” button under ready condition until the letters “FAT” show in the speed window. “FAT” is body fat test mode.
2. Press the “MODE” button to input data into parameters “SEX / AGE / HEIGHT / WEIGHT”. The “TIME/DIST” window will show “-1-”, “-2-”, “-3-”, “-4-“, which corresponds to “SEX / AGE / HEIGHT / WEIGHT” respectively. 01 is MALE, whilst 02 is FEMALE.
3. When setting each parameter, press SPEED ▲/▼ to adjust the data, and CAL/PULSE window will show the data. Press the “MODE” button to finish, and the window will show“-5-” and “-” then it will enter into ready condition. Hold the hand pulse sensors with both hands and it will show your BMI data after 5 seconds.

F-1	Seg	01MALE	02FEMALE
F-2	Age	10-----99	
F-3	Height	100----200	
F-4	Weight	20-----150	
F-5	FAT	≤19	Underweight
	FAT	=(20---25)	Healthy
	FAT	=(25---29)	Overweight
	FAT	≥30	Obese

4.9. MP3 Function (if applicable)

Plug the 3.5mm jack audio cable into any 3.5mm headphone jack slot. Music can be controlled via the MP3 device.

4.10. USB Function (if applicable)

Insert any USB memory stick which contains audio files. You can control the playback via the buttons on the display.

Please keep the volume at appropriate levels to prevent the speakers from damage

7. EXERCISE GUIDE

PLEASE NOTE: Before beginning any exercise program, consult your physician. This is important especially if you are over the age of 45 or individuals with pre-existing health problems.

The pulse sensors are not medical devices. Various factors, including the user's movement, may affect the accuracy of heart rate readings. The pulse sensors are intended only as an exercise aid in determining heart rate trends in general.

Exercising is a great way to control your weight, improve your fitness and reduce the effect of aging and stress. The key to success is to make exercise a regular and enjoyable part of your everyday life.

The condition of your heart and lungs and how efficient they are in delivering oxygen via your blood to your muscles is an important factor to your fitness. Your muscles use this oxygen to provide enough energy for daily activity. This is called aerobic activity. When you are fit, your heart will not have to work so hard. It will pump a lot fewer times per minute, reducing the wear and tear of your heart.

So as you can see, the fitter you are, the healthier and greater you will feel.

Warm-up

Start each workout with 5 to 10 minutes of stretching and some light exercises. A proper warm-up increases your body temperature, heart rate and circulation in preparation for exercise. Ease into your exercise.

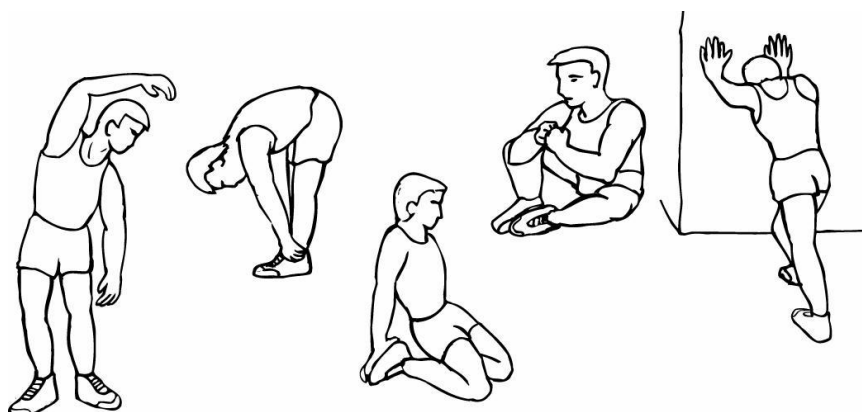

Training Zone Exercise

After warming up, increase the intensity to your desired exercise program. Be sure to maintain your intensity for maximum performance. Breathe regularly and deeply as you exercise.

Cool Down

Finish each workout with a light jog or walk for at least 1 minute. Then complete 5 to 10 minutes of stretching to cool down. This will increase the flexibility of your muscles and will help prevent post-exercise problems.

Workout Guidelines

TARGET ZONE

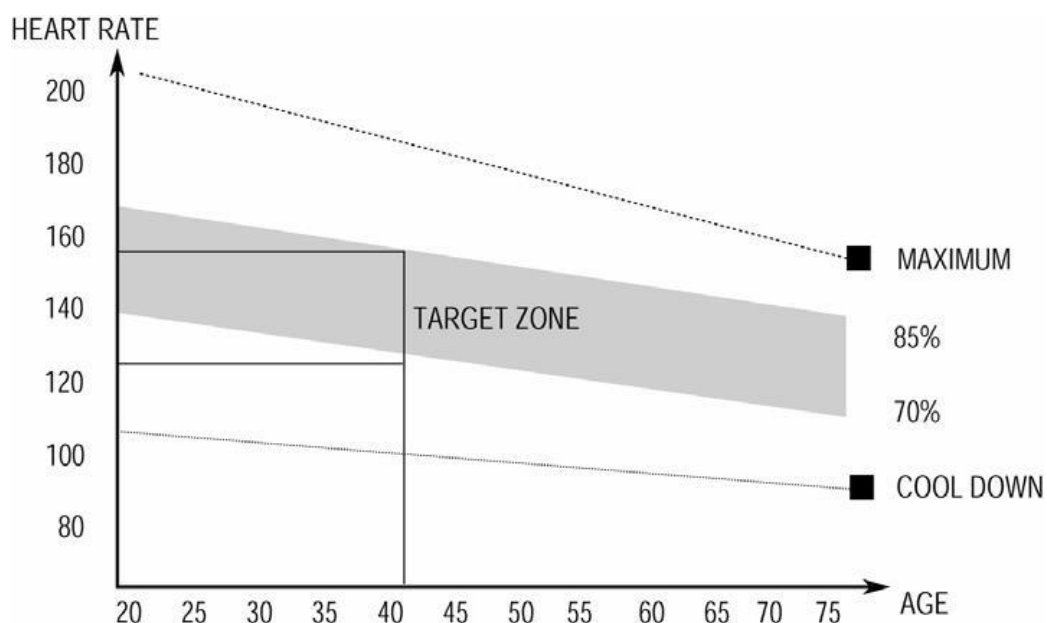

This is how your pulse should behave during general fitness exercise. Remember to warm up and cool down for a few minutes.

The most important factor here is the amount of effort you put in. The harder and longer you work, the more calories you will burn.

8. MAINTENANCE INSTRUCTIONS

Reasonable cleaning/lubricating should be made to extend the life time of this unit. Performance is maximized when the belt and mat are kept as clean as possible.

WARNING: THE MAT/DECK FRICTION MAY PLAY A MAJOR ROLE IN THE FUNCTION AND LIFE OF YOUR TREADMILL AND THAT IS WHY WE RECOMMEND YOU CONSTANTLY LUBRICATE THIS FRICTION POINT TO PROLONG THE USEFUL LIFE OF YOUR TREADMILL. FAILING TO DO THIS MAY VOID YOUR WARRANTY.

WARNING: UNPLUG POWER CORD BEFORE MAINTENANCE

WARNING: STOP TREADMILL BEFORE FOLDING

1. General Cleaning

- Use a soft, damp cloth to wipe the edge of the belt and the area between the belt edge and frame. A mild soap and water solution along with a nylon scrub brush will clean the top of the textured belt. This task should be done once a month. Allow to dry before using.
- On a monthly basis, vacuum underneath your treadmill to prevent dust build up. Once a year, you should remove the black motor shield and vacuum out dirt that may accumulate.

2. General Care

- Check parts for wear before use.
- Pay particular attention to the fixing knobs and make sure they are tight.
- Always replace the mat if worn and any other defective parts.

- If in doubt do not use the treadmill and contact us.

TAKE CARE TO PROTECT CARPETS AND FLOOR in case of leakages. This product is a machine that contains moving parts which have been greased / lubricated and could leak.

3. Belt/Deck/Roller Lubrication

The mat/deck friction may play a major role in the function and life of your treadmill and that is why we recommend you constantly lubricate this friction point to prolong the useful life of your treadmill. You should apply lubrication after approximately the first 30 hours of operation. We recommend lubrication of the deck according to the following timetable:

- Light use (less than 3 hours per week) every 6 months
- Medium use (3-5 hours a week) every 3 months
- Heavy use (more than 5 hours per week) every 6-8 weeks

See below procedures for lubricating:

1. Use a soft, dry cloth to wipe the area between the belt and deck.
2. Spread lubricant onto the inside surface of belt and deck evenly (make sure the machine is turned off and power is disconnected).

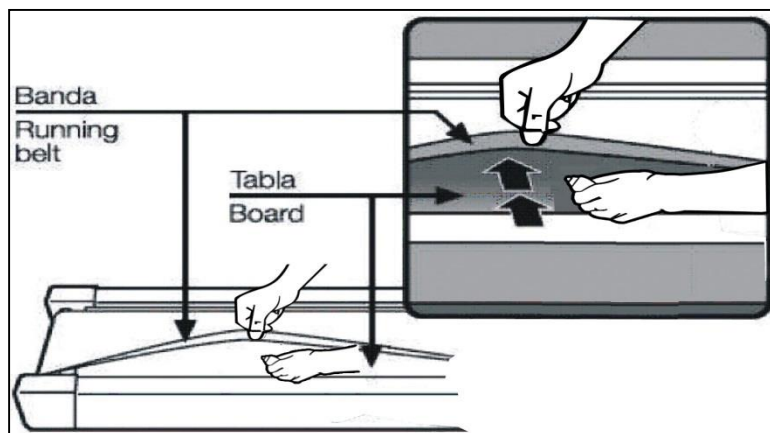

3. Periodically lubricate the front and rear rollers to keep them at their peak performance. If the treadmill belt/deck/roller is kept reasonably clean it is possible to expect over 1200 hours before relubricating is necessary.

Video Tutorial Available at:
<http://youtu.be/cP9NtFHfWlc>

Lifespan Fitness Channel:
<http://www.youtube.com/user/treadmillsvideos>

4. How to check the running mat for proper lubrication:

1. Disconnect the main power supply.
2. Fold the treadmill up into the storage position.
3. Feel the underside surface of the running mat.

If the surface is slick when touched, then no further lubrication is needed.

If the surface is dry to the touch, apply a suitable silicone lubricant.

We recommend that you use a silicone based spray to lubricate your Lifespan treadmill. This can be purchased directly from us or any hardware store.

5. Adjusting the Running Belt

Place treadmill on a level surface. Run treadmill at approximately 4km/h, checking the running condition.

If the belt has drifted to the **right**:

Whilst the treadmill is running at 4km/h, carefully turn the **right** adjusting bolt 1/4 turn **clockwise**. Then monitor treadmill until the belt centers. Repeat until the belt correctly centers.

See *Picture A*

If you have over adjusted the belt and it drifts to the right, carefully turn the **right** adjusting bolt **anticlockwise** until the belt centers.

If the belt has drifted to the **left**:

Whilst the treadmill is running at 4km/h, carefully turn the **left** adjusting bolt 1/4 turn **clockwise**. Then monitor treadmill until the belt centers. Repeat until the belt correctly centers.

See *Picture B*

If you have over adjusted it, carefully turn the **left** adjusting bolt **anticlockwise** and until the belt centers.

To adjust the **tightness** of the belt:

Turn the treadmill off. Turn both the left and right adjusting bolts 1/4 turn clockwise. Repeat until the belt correctly tightens.

See *Picture C*

If the belt is over tightened, simply do the opposite to loosen.

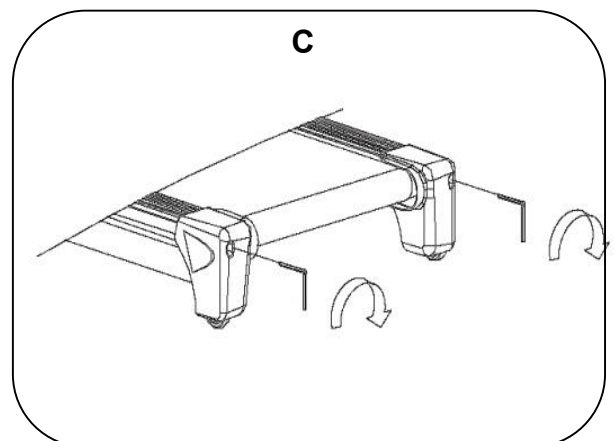
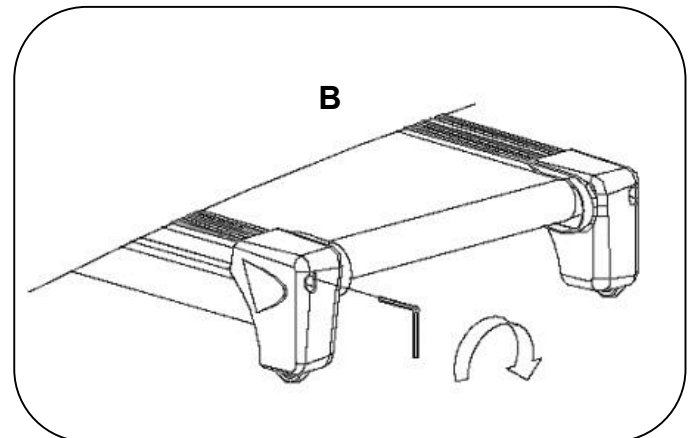
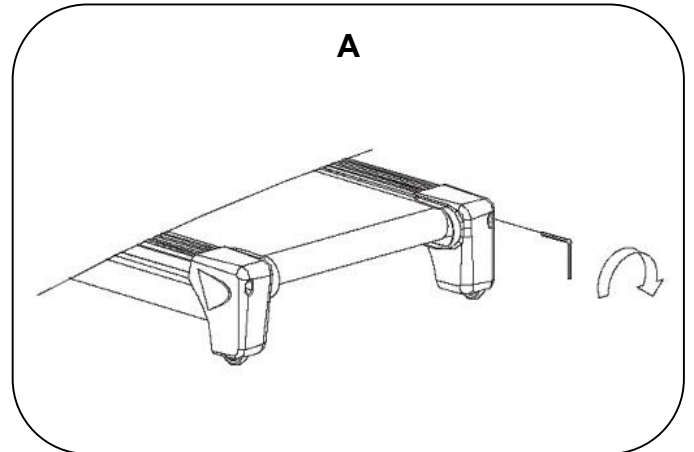

NOTE: When properly tightened, you should be able to peel the very edge of the side of the belt up approximately 2 inches. However this is a rough reference and not all treadmills are the same. Some treadmills that have longer belts may give different measurements for correct belt tightness.

Simply, if the belt begins to slip during use, this is an indication that the belt still needs tightening.

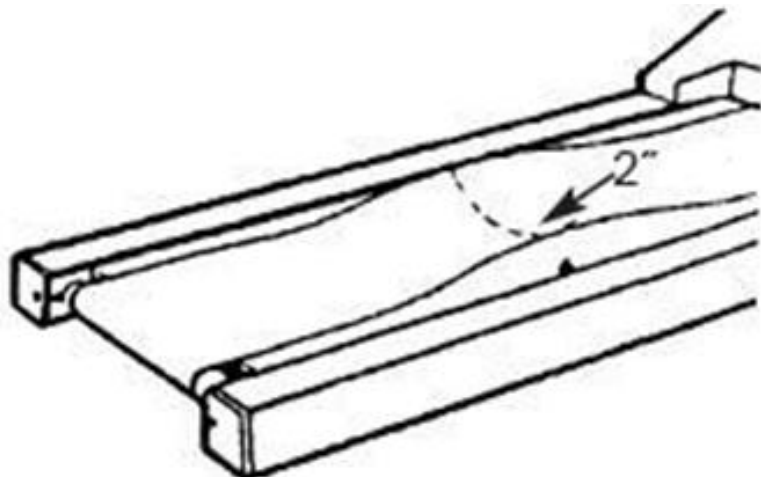

Video Tutorial Available at:
<http://youtu.be/vllsamTSvvA>

Lifespan Fitness Channel:
<http://www.youtube.com/user/treadmillsvideos>

6. Replacing Motor Brushes

After extended use, the motor brushes in your treadmill motor will wear down, and this can lead to motor failure. It is important that you maintain your motor by replacing the brushes on either side of the motor when they are worn down. We recommend that you check your motor every 1000 hours of usage.

IMPORTANT: Before beginning the replacement of your motor brush, ensure that the treadmill is off and unplugged from the electrical socket.

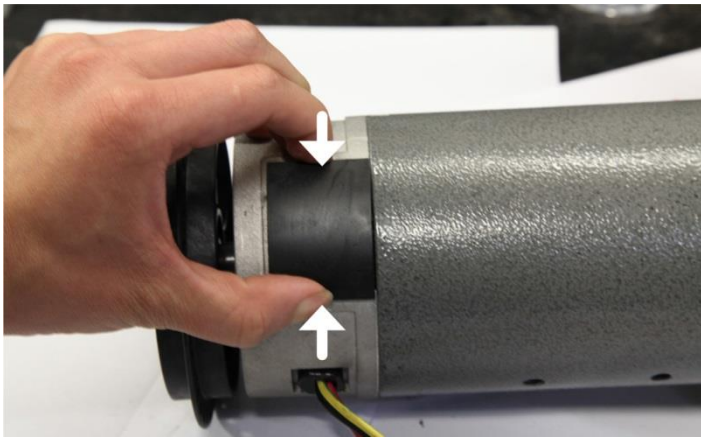

1. Remove the cover from the motor by squeezing it from the sides.

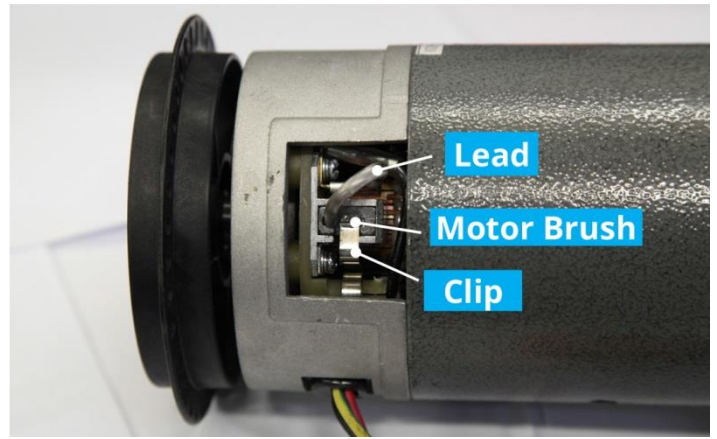

2. You'll find the motor brush held in with a clip, with the lead plugged in.

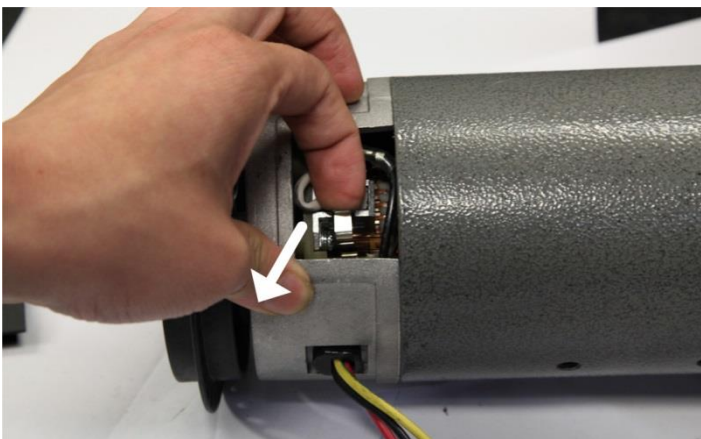

3. Pull the clip out from its position.

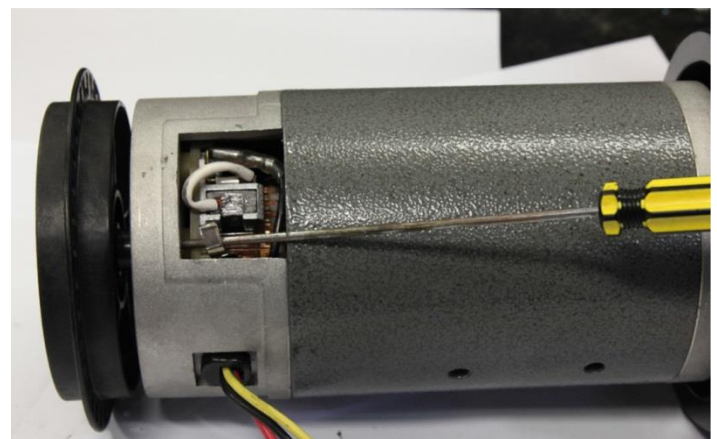

4a. Hold the clip out of the way with a screwdriver or similar object. Keep the screwdriver in this position until step 9.

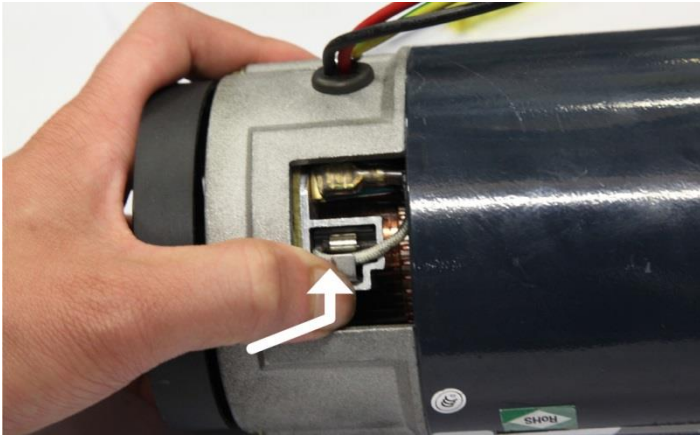

4b. Some treadmill motors may use a push clip instead. In this case, gently push the clip inwards and then up to release it from its latch.

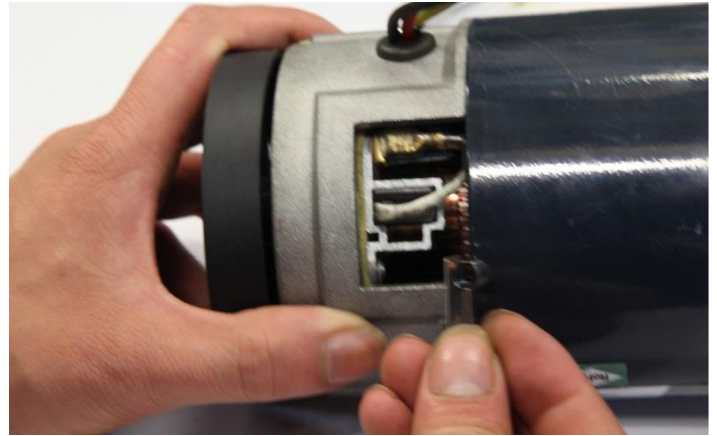

4c. Remove the clip, noting the direction in which it was originally placed, and put it safely aside.

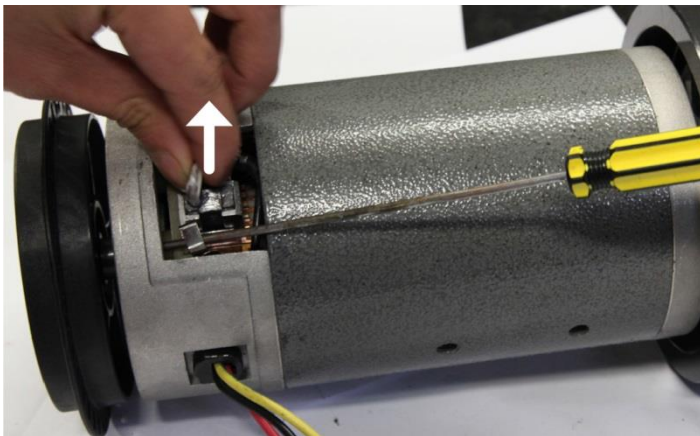

5. Slide the motor brush out from its slot. If the brush is shorter than 2cm on the longest side, you will need to replace both brushes.

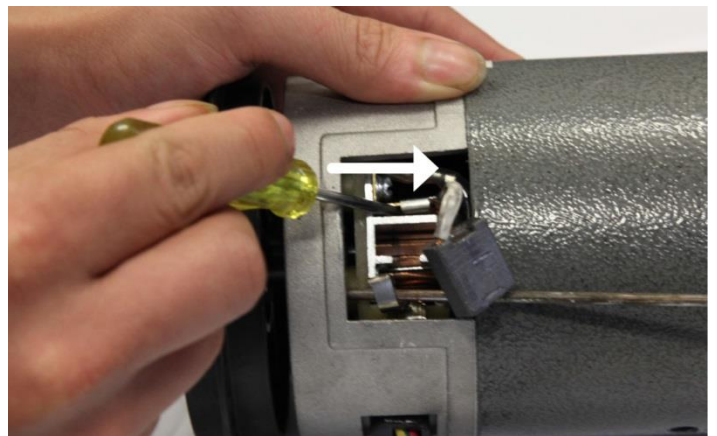

6. Slide the motor brush lead off the terminal using a another small screwdriver or needle-nosed pliers.

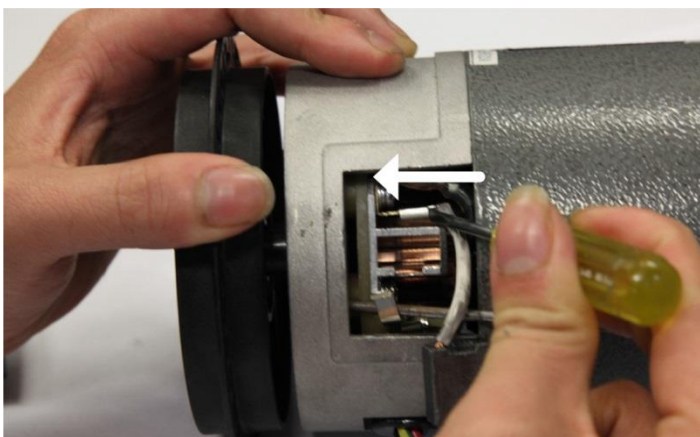

7. Plug the new motor brush lead into the terminal.

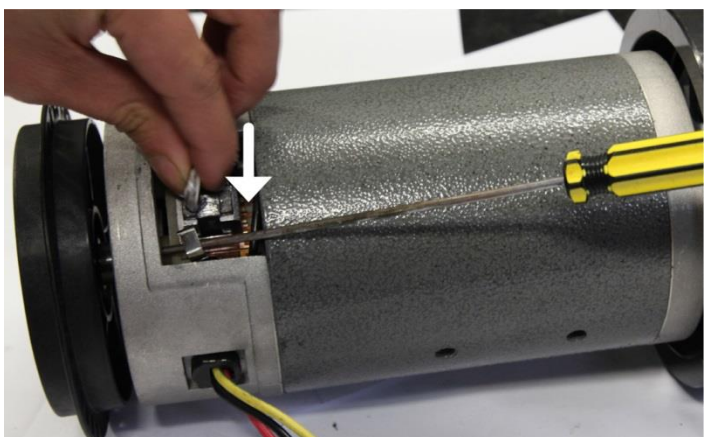

8. Slide the new motor brush into the slot.

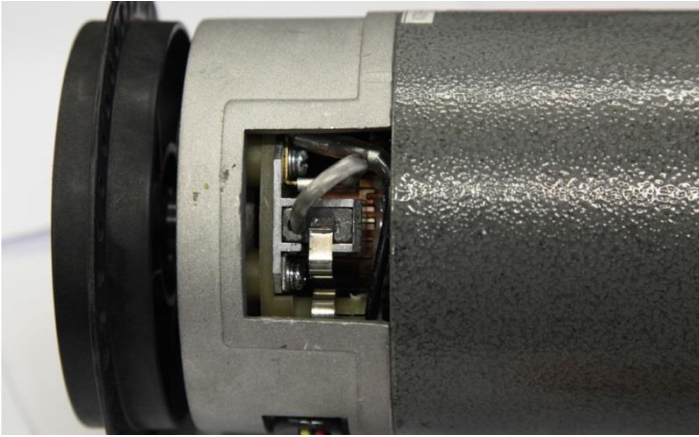

9a. Release the clip back into its position.

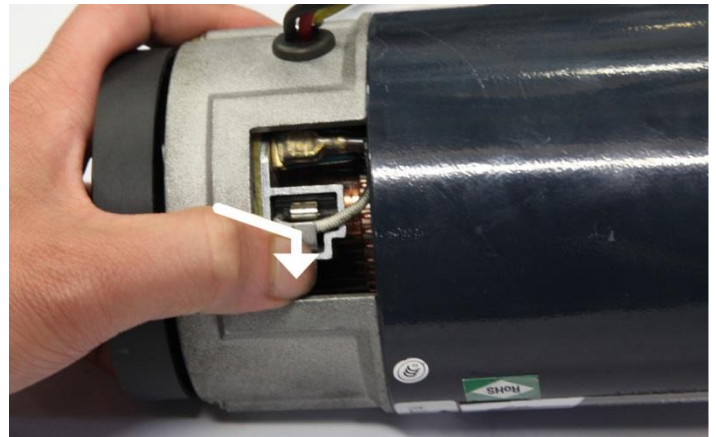

9b. If your motor uses a push clip, replace the push clip by pushing it inwards and then down so that it engages the catch.

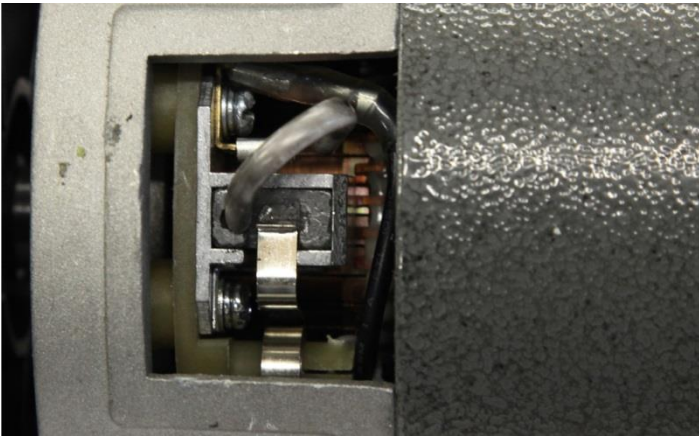

10. Check that the motor brush is held firmly in place by the clip, and that the lead is plugged securely onto the terminal.

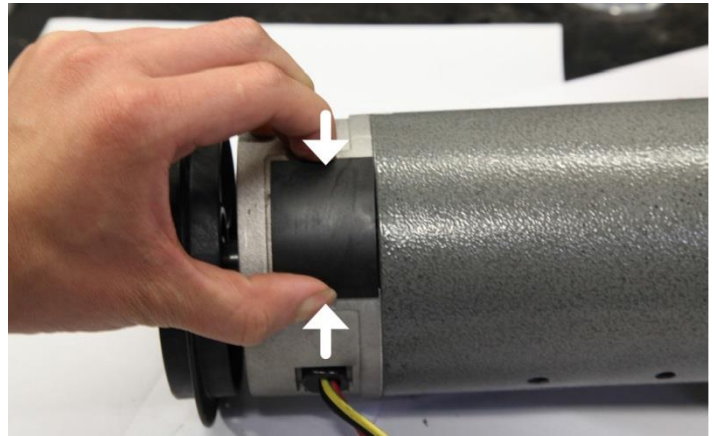

11. Replace the motor cover. Repeat steps 1-15 for the second brush located on the opposing side of the motor.

12. You have now successfully replaced the motor brushes. We also recommend that you remove any dirt and dust from your treadmill motor fan using a vacuum cleaner before replacing the cover.

9. EXPLODED DIAGRAM

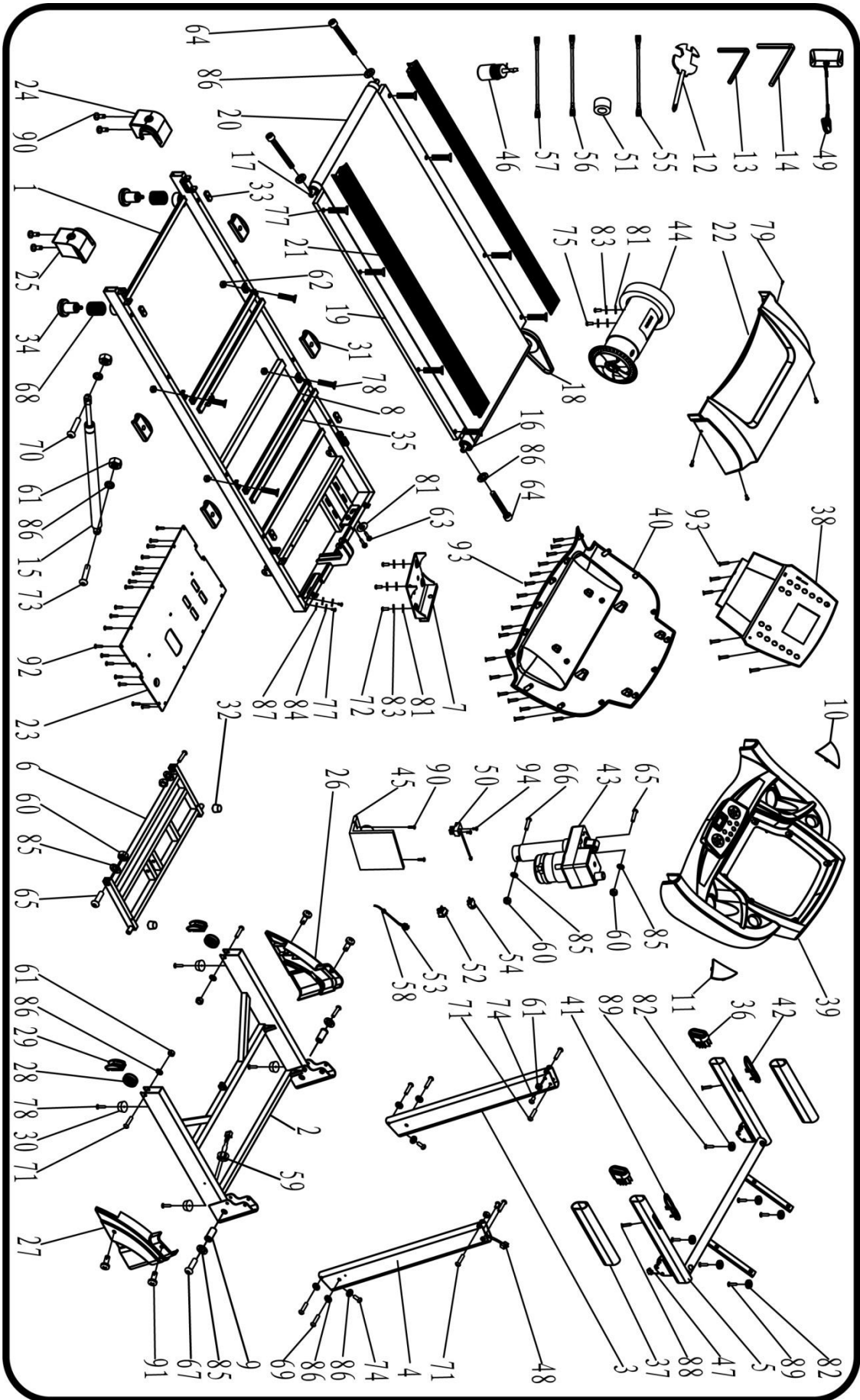

10. PARTS LIST

NO.	DESCRIPTION		Qty	No.	DESCRIPTION		Qty
1	Main frame		1	49	Safety key		1
2	Base frame		1	50	Light sensor		1
3	Left upright		1	51	Magnet Ring		1
4	Right upright		1	52	Power Switch		1
5	Computer Bracket		1	53	Power Line		1
6	Incline Bracket		1	54	Overload protection		1
7	Motor Bracket		1	55	AC Single Wire		1
8	Running board Strengthen Tube		2	56	Blue Single Wire		1
9	Rotate Tube		2	57	Brown Single Wire		1
10	Left loudspeak net		1	58	Power cord		1
11	Right loudspeak net		1	59	Ring substantial plug		2
12	wrench w/screw driver	S=13、14、15	1	60	Bolt	M10	4
13	#5 Allen wrench	5mm	1	61	Bolt	M8	6
14	#6 Allen wrench	6mm	1	62	Bolt	M6	4
15	Cylinder		1	63	washer	M8*30	2
16	Front roller		1	64	Bolt	M8*65	3
17	Rear roller		1	65	Bolt	M10*42	3
18	Motor Belt		1	66	Bolt	M10*85	1
19	Running Board		1	67	Bolt	M10*65	2
20	Running Belt		1	68	Bolt		2
21	Side Rail		2	69	Bolt	M8*45	4
22	Motor Cover		1	70	Bolt	M8*42	1
23	Bottom Shutters		1	71	Bolt	M8*40	4
24	Left back cover		1	72	Bolt	M8*32	4
25	Right back cover		1	73	Bolt	M8*25	2
26	Left Hand cover		1	74	Bolt	M8*16	6
27	Right Hand cover		1	75	Bolt	M8*12	2
28	Transportation wheel		2	76	Bolt	M6*40	8
29	Transportation wheel cover		2	77	Bolt	M5*15	2
30	Feet Pad		4	78	Bolt	M6*16	8
31	Elastic Cusion		2	79	Bolt	M5*8	4
32	Undercut Collusion		2	80	washer	10	2
33	Rubber Pad		4	81	washer	8	7
34	Rubber Feet Pad		2	82	washer	6	6
35	EVA		2	83	Lock Washer	8	6
36	Pad oblique tube plug		2	84	Lock Washer	5	2
37	Foam grip		2	85	Lock Washer	10	4
38	Console panel		1	86	Lock Washer	8	15
39	Computer top cover		1	87	Flat Washer	5	2
40	Computer bottom cover		1	88	Bolt	ST4.2*45	2
41	Hand Pulse with Speed+/- button		1	89	Bolt	ST4.2*20	6

42	Hand pulse with incline +/- button		1	90	Bolt	ST4.2*19	6
43	Incline Motor		1	91	Bolt	ST4.2*19	4
44	DC Motor		1	92	Bolt	ST4.2*12	18
45	Control Board		1	93	Bolt	ST4.2*13	27
				94	Bolt	ST2.9*6.5	2
47	Computer up wire		1				
48	Computer bottom wire		1				

11. WARRANTY

AUSTRALIAN CONSUMER LAW

Many of our products come with a guarantee or warranty from the manufacturer. In addition, they come with guarantees that cannot be excluded under the Australian Consumer Law. You are entitled to a replacement or refund for a major failure and compensation for any other reasonably foreseeable loss or damage.

You are entitled to have the goods repaired or replaced if the goods fail to be of acceptable quality and the failure does not amount to a major failure. Full details of your consumer rights may be found at www.consumerlaw.gov.au

Please visit our website to view our full warranty terms and conditions:

<http://www.lifespanfitness.com.au/warranty-repairs>

Warranty and Support:

Please email us at support@lifespanfitness.com.au for all warranty or support issues.

For all warranty or support related enquiries an email must be sent before contacting us via any other means.

TROUBLE SHOOTING

CODE	REASON	SOLUTION
E01	Message failure between computer and bottom control board	A. Check the computer and bottom control board wire connection; B. Check if IC on bottom control board is loose, reset the IC C. Power on bottom control board, if there is an error, change the bottom control board
E02	Burst clash	1. Check that the power voltage is suitable, if not, use correct power voltage; 2. Check if the bottom control is burnt out; if yes - replace; then reconnect the motor wire.
E05	Current overload protection	1. Over rated loaded or the motor is stuck, causing excessive current, machine will start self-protection system. Adjust the machine and restart; 2. Check if there is irregular noise coming from the motor or if the motor / bottom control board is burnt out; if burnt out, change to a good motor and bottom control; remember to use the correct voltage.
E08	EEPROM with problem	Change the bottom control board

Hand Pulse Technology

Our products come equipped with hand pulse sensors which are used to pick up tiny EKG/ECG signals that run through the body when your heart beats. These electrical EKG/ECG signals are very small and that they must be amplified 1000 times to make the signal useful for the computer to display your pulse.

To ensure proper operation:

- The user must maintain good, consistent contact on all four sensors
- The users skin cannot be too dry or too wet

Other factors that could affect the reading:

- Change of grip on the sensors (during slow pace walking and up to running)
- Tightening of hand muscles will produce small electrical signals
- Static electricity charges from the air or from walking on the treadmill

EKG/ECG Sensors may filter through actual EKG/ECG signals and “Noise” factors that may affect the reading.

This will cause the pulse reading to be delayed and will take longer to update the display as the heart rate changes. Too much noise will create an incorrect reading. Medical conditions or having no electrical signal in the hands are other factors that may affect pulse readings as well.

These are limitations of hand pulse technology and even the most expensive systems (which can cost upwards of \$3,000) used in hospitals have the same problems. The difference is that a patient in a hospital is not running on a treadmill. Hand pulse technology works well on stationary exercise machines like bikes and even elliptical cross trainers but are not perfect on a treadmill. We offer treadmills with a wireless heart rate receiver which may be a more accurate option.

To test if your hand pulse sensors are working up to specification, hold them while standing on the side step rails, not walking, and see if the reading is more in line with what you would expect. This will eliminate the movement and static electricity factors. If your hands are dry, then wet them slightly (saliva works as a great conductor if this doesn't bother you).

For more information, please contact our Lifespan Technical Support Department

www.lifespanfitness.com.au

support@lifespanfitness.com.au