

KINGSMITH WalkingPad Treadmill User Manual

Please read this manual carefully before using and then keep it in a safe place.



Manufacturer: Beijing Kingsmith Technology Co., Ltd.
Address: Floor 4, Building 25, Area 18, ABP Park, Fengtai, Beijing, China.

MADE IN CHINA

Model No. : *TRMC21F*



IMPORTANT SAFETY INSTRUCTIONS

The appliance is intended for residential use.



DANGER – To reduce the risk of electric shock:

Always unplug this appliance from the electrical outlet immediately after using and before cleaning.



WARNING – To reduce the risk of burns, fire, electric shock, or injury to persons:

- 1) An appliance should never be left unattended when plugged in. Unplug from outlet when not in use, and before putting on or taking off parts.
- 2) Close supervision is necessary when this appliance is used by, or near children, invalids, or disabled persons.
- 3) Use this appliance only for its intended use as described in this manual. Do not use attachments not recommended by the manufacturer.
- 4) Never operate this appliance if it has a damaged cord or plug, if it is not working properly, if it has been dropped or damaged, or dropped into water. Return the appliance to a service center for examination and repair.
- 5) Do not carry this appliance by the supply cord or use the cord as a handle.
- 6) Keep the cord away from heated surfaces.
- 7) Never drop or insert any object into any opening.
- 8) Do not use outdoors.
- 9) Do not operate where aerosol (spray) products are being used or where oxygen is being administered.
- 10) To disconnect, turn **all** controls to the off position, then remove the plug from the outlet.

IMPORTANT SAFETY INSTRUCTIONS



1. This appliance can be used by children aged from 8 years and above and persons with reduced physical, sensory or mental capabilities or lack of experience and knowledge if they have been given supervision or instruction concerning use of the appliance in a safe way and understand the hazards involved. Children shall not play with the appliance. Cleaning and user maintenance shall not be made by children without supervision.

2. Correct Disposal of this product. This marking indicates that this product should not be disposed with other household wastes throughout the EU. To prevent possible harm to the environment or human health from uncontrolled waste disposal, recycle it responsibly to promote the sustainable reuse of material resources. To return your used device, please use the return and collection systems or contact the retailer where the product was purchased. They can take this product for environmental safe recycling.

This appliance is not intended for use by persons (including children) with reduced physical, sensory or mental capabilities, or lack of experience and knowledge, unless they have been given supervision or instruction concerning use of the appliance by a person responsible for their safety.

Children should be supervised to ensure that they do not play with the appliance.

WARNING: keep young children away from this machine at all times. Contact with the moving surface may result in severe friction burns.

1. IEC: This appliance is not intended for use by persons (including children) with reduced physical, sensory or mental capabilities, or lack of experience and knowledge, unless they have been given supervision or instruction concerning use of the appliance by a person responsible for their safety. (this appliance can be used by children aged from 8 years and above and persons with reduced physical, sensory or mental capabilities or lack of experience and knowledge if they have been given supervision or instruction concerning use of the appliance in a safe way and understand the hazards involved)

2. Children should be supervised to ensure that they do not play with the appliance. (children shall not play with the appliance, cleaning and user maintenance shall not be made by children without supervision)

Contents

| | |
|--------------------------------|----|
| 1. Products and accessories | 02 |
| 2. Function diagram | 03 |
| 3. Novice Guide | 07 |
| 4. How to use the treadmill | 09 |
| 5. Trademark and Legal Notice | 12 |
| 6. Safety precautions | 13 |
| 7. Maintenance and Adjustments | 16 |
| 8. Replacement and Disposal | 17 |

Welcome

Thank you for choosing Kingsmith WalkingPad treadmill, hereinafter referred to as treadmill. It has exquisite, simple and innovative overall design, and you can have a quality and healthy life by exercising at home. This product is only designed for home use, not for commercial such as for business, rental or public group use.

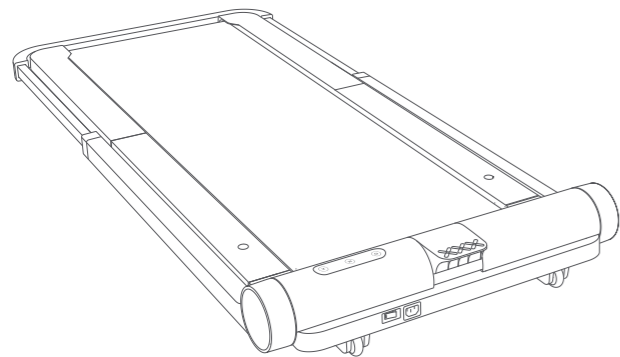

| Reference Index | Parameter |
|-----------------|---|
| Applicable Age | 14-60 years old |
| Speed Range | Walking Mode: 0.5-6km/h(0.5-3.7mi/h) Running Mode: 0.5-10km/h(0.5-6.2mi/h) |
| Running Area | 440×1200 mm (17"×47") |
| Max Load | 110 kg (240 lbs) |
| Frequency | 50/60 Hz |
| Voltage | 220-240 V~ |
| Power Input | 918 W |
| Net Weight | 37.5 kg (82.6 lbs) |
| Unfold Size | 1455×700×1070 mm (57.4"×27.5"×42.1") |
| Folded Size | 1025×700×155 mm (40.1"×27.5"×6") |
| Working Mode | Running Mode/Walking Mode |

1. Products and accessories

Please carefully check whether the items of the packing box are complete and intact. If there is anything missing or damaged. Please contact the seller.

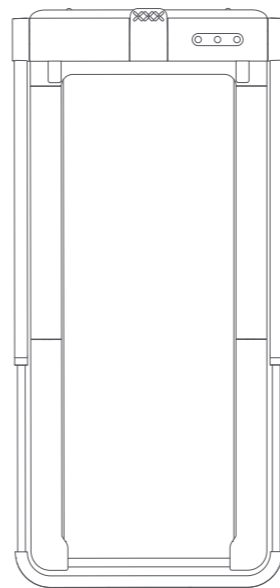

Treadmill

Assesories



Power cord



Remote control



Remote control lanyard



Hex L Shaped Wrench

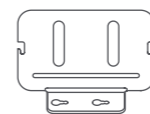

Mobile phone bracket



Safety lock



Silicone oil

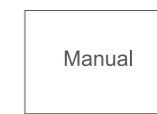

User Manual

2. Function diagram

1. Walking mode

When the armrest is down, it is in walking mode, and the maximum speed can be achieved 6km/h. You can also choose to use manual mode (M) and automatic mode (A).

When using the device for the first time, there will be a speed limit of 3km/h in automatic mode (A). After completing the novice guidance on "KS fit" software, you can unlock the device to 6km/h, and you can also set the speed limit on your own in the software.

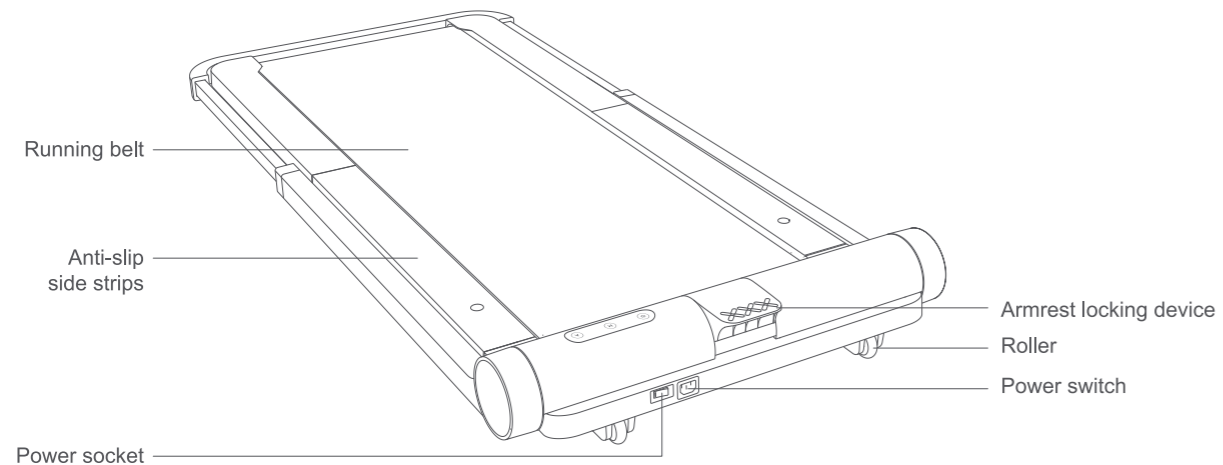

2. Running mode

When the armrest is up, it is in running mode. The maximum speed in this mode can be achieved is 10km/h. You can also use manual mode (M). For safety purpose, running mode does not support automatic mode (A).

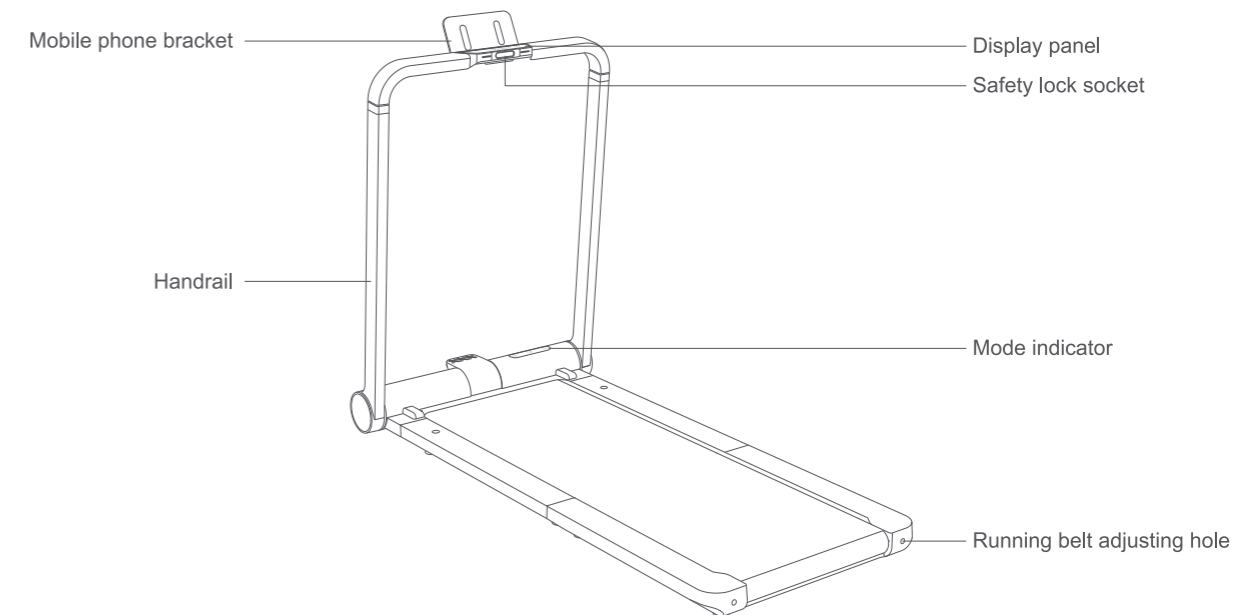

3. Display panel function introduction



4. Mode indicator

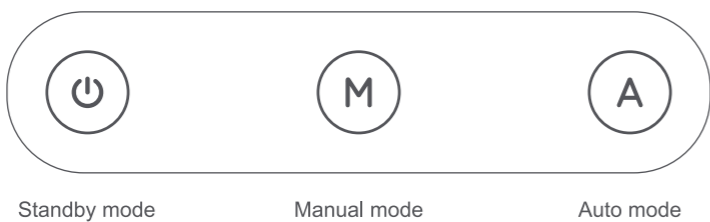

5. Remote control

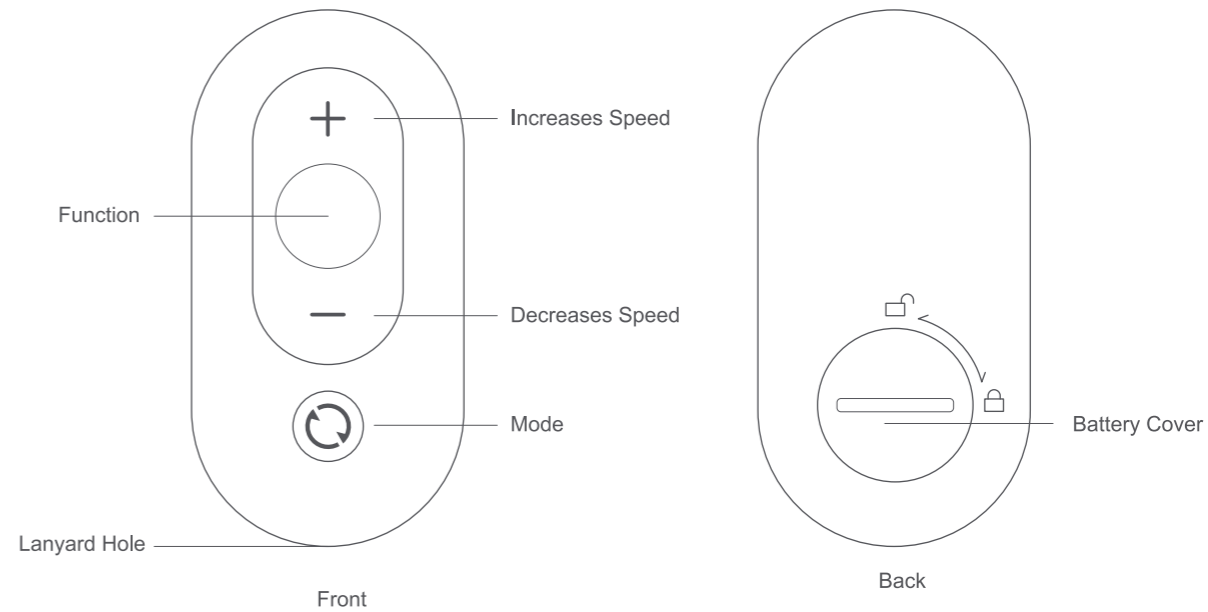

3. Novice Guide

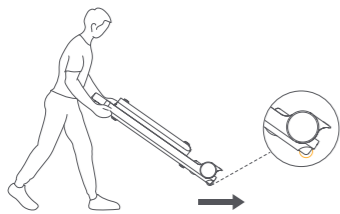

1. When pushing and pulling, please make sure that the running board is in the locked state, and place it on the flat ground.

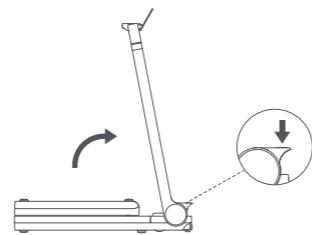

2. Pull up the locking rod of the running board to unlock the running board and slowly level it.

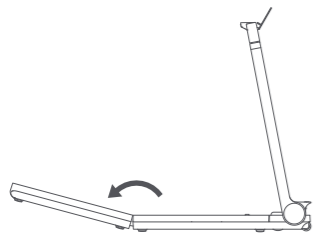

3. Unfold the treadmill, adjust the running belt to the center position, slowly unfold it and assist to press it down to make it completely flat, or rotate the bottom foot pad for leveling.

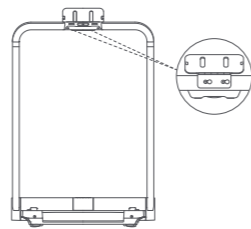

4. Take out the mobile phone bracket from the accessory box, put the two large holes on the fixing bolts on the lower side of the armrest, and then push them in the direction of the small holes and clamp them.

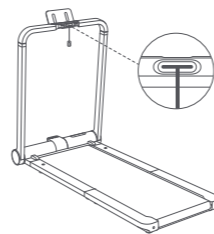

5. Take out the safety lock from the accessory box and insert it into the safety lock seat in the middle of the armrest.



7. Scan the QR code above or search the app store for "KS fit" and complete the installation and registration.

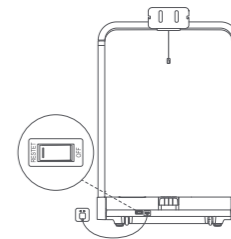

6. After connecting the power cord, turn on the treadmill switch.

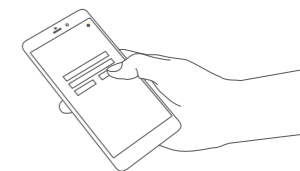

8. Open the app of mobile phone, add and bind the treadmill with mobile phone according to the prompts. It is time to use the treadmill.

4. How to use the treadmill

1. Mode description



Standby mode

The standby mode light is on, and the motor and sensor stop responding.



Manual mode

The manual mode light is on, and the movement speed is controlled by the remote control or APP.



Auto mode

The auto mode light is on, and the speed is automatically controlled through intelligent algorithms.

* The equipment system will be regularly upgraded and optimized, and some operations may be adjusted.

2. Standby mode control instructions



Standby mode

In standby mode, you can short press the mode button on the remote control to activate the treadmill and switch to the default manual mode.

When the treadmill is not in running state, long press the mode button on the remote control to switch to the standby state.

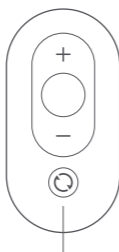

Remote control legend

Short press: mode switch

Long press: switch to standby mode (non-running state)

3. Manual mode control instructions (Beginner mode)



Manual mode

In this mode, the remote control can be used to control the treadmill. It is recommended that beginners use the manual mode first, and then use the automatic mode after proficiency in using the treadmill.

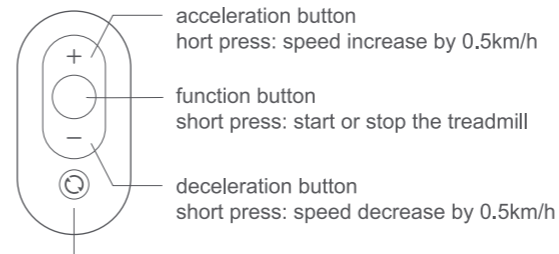

acceleration button

short press: speed increase by 0.5km/h

function button

short press: start or stop the treadmill

deceleration button

short press: speed decrease by 0.5km/h

mode button

Short press: mode switch; Long press: switch to standby mode (non-running state)

4. Description of automatic mode control (advanced mode)



Auto mode

This mode is an advanced mode, which is difficult to control and can be used completely without the remote control. It is recommended for skilled people to use the treadmill.

The remote control starts and stops, and the mode switch button is effective in this mode.

* The automatic mode is only available when the treadmill is in walking mode.

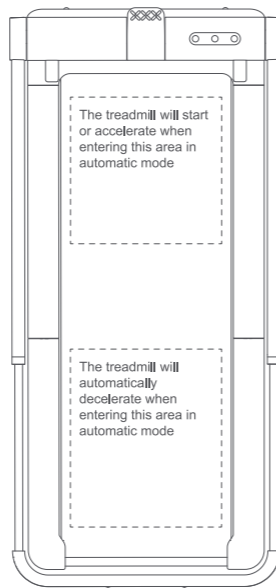

5. Trademark and Legal Notice

5. Remote control pairing instructions

If the remote control does not respond or you have replaced the remote control, you need to pair it again.

Pairing method: reboot, press and hold the mode button on the remote control within 5 seconds.

6. Connection Caution Light

Not connected to APP: Will flicker

Connected to APP: Off

7. Fault warning light

- E01: Software overcurrent
- E02: Hardware overcurrent
- E03: IPM module overheating
- E04: Undervoltage protection
- E05: Overvoltage protection
- E06: Motor phase loss protection
- E07: Motor locked-rotor protection
- E08: Sensor failure
- E09: Motor cannot start
- E12: Motor overcurrent protection
- E13: Overload protection
- E14: Hall signal missing
- E15: Communication problem

The patents involved in Kingsmith WalkingPad Treadmill series products are made by Beijing Kingsmith Technology Co., Ltd. and owned by the Company. No organization or individual may copy, distribute all or any part of this manual without Kingsmith's written permission, and may not use these patents without authorization.

When printing this manual, we have put various functional descriptions and instructions in it as far as possible. However, due to the continuous improvement of product functions and design changes, there may still be discrepancies with the products you purchased. Due to product update, this manual may deviate from the actual product in terms of color, appearance, etc. Please refer to the actual product.

6. Safety precautions

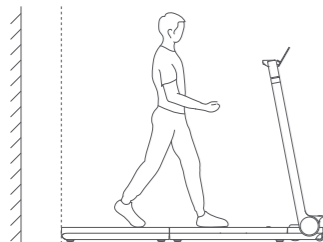

⚠ The distance behind the treadmill should be superior to 2000 mm. You can hold the handrail tightly to support your body and jump away from the treadmill.

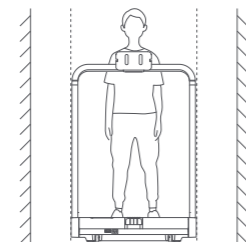

⚠ The distance on each side of the treadmill should be superior to 500 mm.

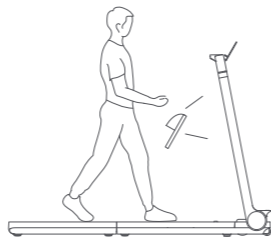

⚠ Please wear sports shoes and clothes and exercise moderately when using the treadmill. If you feel uncomfortable during running, please stop immediately and consult a doctor. Otherwise, you may risk injuries.

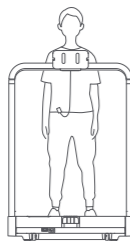

⚠ Test the safe lock before using the treadmill. Please clip the end of the safe lock on your clothes when running on the treadmill. If there is an unexpected situation, pull off the safe lock to stop the treadmill immediately.

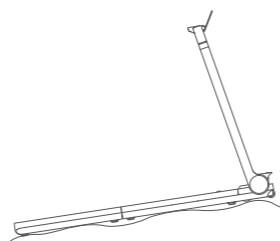

⊗ Do not operate the treadmill in damp or wet locations. Do not use it on irregular ground.

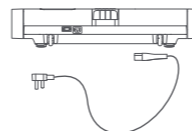

⚠ Please unplug the power cord when not in use.

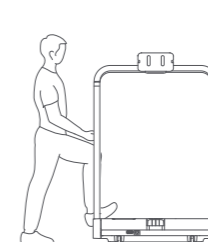

⊗ Do not step on the head of the treadmill.

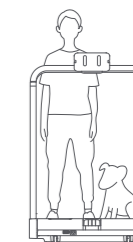

⊗ Do not bring pets when using the treadmill.

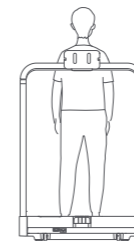

⊗ Do not use the treadmill backwards or sideways.

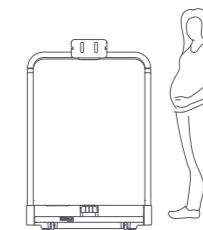

⚠ Elderly people, children, and pregnant women should use caution when using the treadmill.

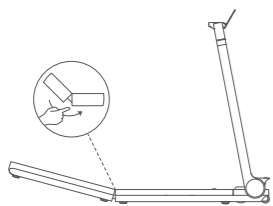

⚠ Watch your hands.

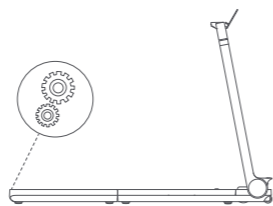

⚠ Take care of your belongings.

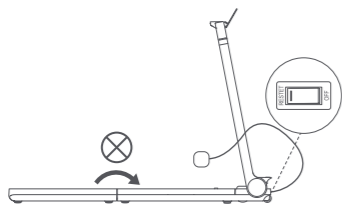

⊗ Do not fold before power off.

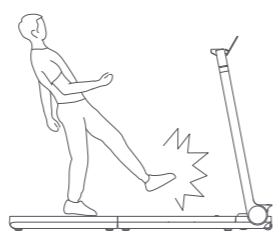

⊗ Do not get on and off when the treadmill operating.

7. Maintenance and Adjustments

1. Clean the treadmill



- Disconnect all sources of power before cleaning the treadmill.
- Add a small quantity of mild cleaner to a 100% cotton cloth. Do not spray the cleaner directly on the walking belt or use acidic and corrosive cleaner.
- Do not wipe under the walking belt.
- After a period of exercise, dust and stains may appear on the rear floor. This is normal and can be simply wiped.

2. Walking Belt Slipping and Correction

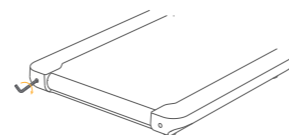

- Simultaneously press and hold both Mode Button and Speed Increase Button on the remote control for over 3 seconds until device start.
 - Front panel will show "CALI" and keep running with speed 3km/h (2mi/h).
 - Walking belt goes to the left: Turn the left adjusting hole screw clockwise by 1/4 turn.
 - Walking belt goes to the right: Turn the right adjusting hole screw clockwise by 1/4 turn.
 - Walking belt is slipping: Turn the left and right adjusting screws clockwise for 1/2 turn at the same time.
 - After each adjustment, the treadmill needs to run for 1-2 minutes to verify the adjustments. Please adjust again if necessary.
 - Press the function key to stop treadmill.
- CAUTION: DO NOT OVERTIGHTEN THE BELT. PLEASE MAINTAIN ORIGINAL FACTORY BELT TENSION. EXCESSIVE BELT TENSION WILL CAUSE DAMAGE TO MOTOR.**

3. Walking belt lubrication

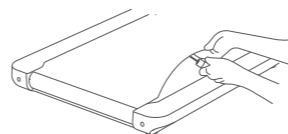

- Power off the treadmill and unplug the power cord.
- Lift the edge of the walking belt and smear the inner surface with silicone oil.
- Start the treadmill to run at a speed of 3 km/h (2 mi/h) for 10-20 seconds.
- 5-10 ml of silicone oil is required for each lubrication. Excessive silicone oil may cause slipping and affect normal use.
- Lubricate the walking belt every three months.

8. Replacement and Disposal



The battery contained in this appliance must be removed for disposal.

When replacing the battery, use only original battery, available from our online parts shop.

The battery compartment is located on the back of the appliance. Open the compartment by removing the screw in the cover using a suitable screwdriver, and then press the lower end of the locking catch on the connectors. In that way, both sides of the connection can be separated by pulling them apart.

When inserting a new battery, push together the two connectors and ensure that the catch locks over the stop.

Never dispose of old battery in domestic garbage, but only through the proper public collection points. This also applies to the battery of defective appliances.



Devices marked with this symbol must be disposed of separately from your household waste, as they contain valuable materials that can be recycled. Proper disposal protects the environment and human health. Your local authority or retailer can provide information on the matter.